



# REGIONAL SEAS

UNITED NATIONS ENVIRONMENT PROGRAMME

## *Combating oil pollution in the Kuwait Action Plan region*

*UNEP Regional Seas Reports and Studies No. 44*

*Prepared in co-operation with*



IMO



ROPME



UNEP 1984

Note: This report was prepared jointly by the International Maritime Organization (IMO), the Regional Organization for the Protection of the Marine Environment (ROPME), and the United Nations Environment Programme (UNEP) under projects FP/0503-80-06 and KA/0503-81-02 as a contribution to the implementation of the Kuwait Action Plan.

The designations employed and the presentation of the material in this document do not imply the expression of any opinion whatsoever on the part of IMO, ROPME or UNEP concerning the legal status of any State, Territory, city or area, or of its authorities, or concerning the delimitation of their frontiers or boundaries.

For bibliographic purposes this document may be cited as:

IMO/ROPME/UNEP: Combating Oil Pollution in the Kuwait Action Plan Region. UNEP Regional Seas Reports and Studies No. 44. UNEP, 1984.



# REGIONAL SEAS

UNITED NATIONS ENVIRONMENT PROGRAMME

## *Combating oil pollution in the Kuwait Action Plan region*

*UNEP Regional Seas Reports and Studies No. 44*

*Prepared in co-operation with*



IMO



ROPME



UNEP 1984

PREFACE

Ten years ago the United Nations Conference on the Human Environment (Stockholm, 5-16 June 1972) adopted the Action Plan for the Human Environment, including the General Principles for Assessment and Control of Marine Pollution. In the light of the results of the Stockholm Conference, the United Nations General Assembly decided to establish the United Nations Environment Programme (UNEP) to "serve as a focal point for environmental action and co-ordination within the United Nations "system" (General Assembly resolution (XXVII) of 15 December 1972). The organizations of the United Nations system were invited "to adopt the measures that may be required to undertake concerted and co-ordinated programmes with regard to international environmental problems", and the "intergovernmental and non-governmental organizations that have an interest in the field of the environment" were also invited "to lend their full support and collaboration to the United Nations with a view to achieving the largest possible degree of co-operation and co-ordination". Subsequently, the Governing Council of UNEP chose "Oceans" as one of the priority areas in which it would focus efforts to fulfil its catalytic and co-ordinating role.

The Regional Seas Programme was initiated by UNEP in 1974. Since then the Governing Council of UNEP has repeatedly endorsed a regional approach to the control of marine pollution and the management of marine and coastal resources and has requested the development of regional action plans.

The Regional Seas Programme at present includes eleven regions <sup>1/</sup> and has over 120 coastal States participating in it. It is conceived as an action-oriented programme having concern not only for the consequences but also for the causes of environmental degradation and encompassing a comprehensive approach to combating environmental problems through the management of marine and coastal areas. Each regional action plan is formulated according to the needs of the region as perceived by the Governments concerned. It is designed to link assessment of the quality of the marine environment and the causes of its deterioration with activities for the management and development of the marine and coastal environment. The action plans promote the parallel development of regional legal agreements and of action-oriented programme activities. <sup>2/</sup>

During its fourth session in 1976 the Governing Council of UNEP approved the preparatory work for convening a Regional Conference on the Protection of Marine and Coastal Environment of Bahrain, Iran, Iraq, Kuwait, Oman, Qatar, Saudi Arabia and the United Arab Emirates. Subsequently, on the basis of a fact-finding mission sponsored by UNEP and supported by several United Nations agencies, a preliminary action plan dealing with the scientific and socio-economic aspects for protection and development of the marine environment of the region was prepared and reviewed by a series of technical meetings of Government-nominated experts. In April 1978 a

---

<sup>1/</sup> Mediterranean Region, Kuwait Action Plan Region, West and Central African Region, Wider Caribbean Region, East Asian Seas Region, South-East Pacific Region, South Pacific Region, Red Sea and Gulf of Aden Region, East African Region, South-West Atlantic Region and South Asian Region.

<sup>2/</sup> UNEP: Achievements and planned development of UNEP's Regional Seas Programme and comparable programmes sponsored by other bodies. UNEP Regional Seas Reports and Studies No. 1. UNEP, 1982.

Regional Conference of Plenipotentiaries was convened in Kuwait for the purpose of reviewing, revising and adopting the action plan and related legal instruments. The Conference, on 23 April 1978, adopted

- (a) the Action Plan for the Protection and Development of the Marine Environment and the Coastal Areas of Bahrain, Iran, Iraq, Kuwait, Oman, Qatar, Saudi Arabia and the United Arab Emirates, <sup>3/</sup>
- (b) the Kuwait Regional Convention for Co-operation on the Protection of the Marine Environment from Pollution, <sup>4/</sup>
- (c) the Protocol concerning Regional Co-operation in Combating Pollution by Oil and other Harmful Substances in Cases of Emergency, <sup>4/</sup>
- (d) resolutions on (i) interim secretariat, (ii) financial arrangements, (iii) steps to be taken for the establishment of the Marine Emergency Mutual Aid Centre, and (iv) co-ordination between the regional marine meteorological and environmental programmes. <sup>3/</sup>

The Action Plan has subsequently become known as the Kuwait Action Plan.

Paragraph 20 of the environmental management component of the Action Plan called for:

"Formulation of regional contingency plans for accidents involving oil exploration, exploitation and transport, and strengthening the meteorological services contributing to the development of contingency plans, and to their execution in co-ordination with existing or future marine regional meteorological programs."

As a contribution toward this end, IMO in co-operation with the Regional Organization for the Protection of the Marine Environment (ROPME) and UNEP, convened in Manama, Bahrain (6 - 10 December 1980) an international workshop on combating marine pollution. It was attended by experts from Bahrain, Iran, Iraq, Kuwait, Oman, Qatar, Saudi Arabia and the United Arab Emirates. A total of 23 papers on various aspects of oil pollution and combating of oil spillages were presented. A report of the workshop has been published by IMO (KAP.WS/5/3). The report contains a commentary on the workshop as well as a brief review of each of the papers presented. In this document are reproduced in full the substantive technical papers presented at the workshop.

---

<sup>3/</sup> UNEP: Action Plan for the protection of the marine environment and the coastal areas of Bahrain, Iran, Iraq, Kuwait, Oman, Qatar, Saudi Arabia and the United Arab Emirates. UNEP Regional Seas Reports and Studies No. 35. UNEP 1983.

<sup>4/</sup> Kuwait Regional Convention for Co-operation on the Protection of the Marine Environment from Pollution and Protocol concerning Co-operation in Combating Pollution by Oil and Other Harmful Substances in Cases of Emergency. UNEP 1983.

CONTENTS

	<u>Pages</u>
GENERAL OVERVIEW	1
A. Al-Zaidan: Kuwait Action Plan - Overall Concept and progress Made	3
R. Golob and E. Brus: Statistical Analysis of Oil Pollution in the Kuwait Action Plan Region and the Implications of Selected World-Wide Oil Spills to the Region	7
A. Nelson-Smith: Effects of Oil-Industry Related Pollution on Marine Resources of the Kuwait Action Plan Region	35
O. Linden: Biological Impact and Effects on Fisheries of Oil Spill in Bahrain, August-September 1980	53
POLLUTION FROM OFFSHORE EXPLORATION AND EXPLOITATION	61
B. Dicks: Exploration and Exploitation of the Seabed for Oil-Biological Impacts in Perspective	63
E. Hull: Training in Oil Well Blow-Out Prevention and the Role of Simulators	89
A.D. Read: Oily Water Discharges from Offshore Oil Installations, Their Origin and Treatment and Some Examples of Their Regulation	95
J.Ph. Poley: Tailored Oil Spill Contingency Planning for Offshore Oil Blow-Outs	115
D.J.S. Brown and A. Baxter: August 1980 Oil Spill Clean-Up Project - Bahrain Report Summary of Task Force Operations	125
W.J. Lehr and H.M. Cekirge: Oil Slick Movements in the Kuwait Action Plan Region	147
F. Krogh: Computer Simulation of Oil Spills State of the Art Regarding Models and Applied Techniques	155
F. Krogh: A Computer-Assisted Oil Spill Contingency Centre with Emphasis on Data Bases, Risk and Consequence Analysis	185
SAFETY OF NAVIGATION AND POLLUTION PREVENTION	225
A.W. Dakkak: Role of Weather Data in Safe Operations in Oil Exploration, Exploitation and Transport	227

	<u>Pages</u>
H. Hollins: Maritime Traffic Control and Aids to Navigation in the Kuwait Action Plan Region and the Approaches Thereto	233
J. Plenter: Pollution Prevention and Control	247
J. Deck III: Recent IMO Developments Relating to Marine Safety	257
J. Wonham: IMO and Its Activities with Particular Reference to the Prevention and Control of Marine Pollution	269
T.P. Hebden: Pollution in the Shipping Industry - Prevention is Better than Cure	303
COMBATING OF OIL SPILLAGE	309
I.C. White and J.A. Nichols: Methods Available for Combating Oil Spillages	311
P.B. Ryan: Marine Oil Spill Response Capability in the Kuwait Action Plan Region	327
J.E. Cuddeback and K. Al-Qatari: Aramco Oil Spill Prevention and Response Programme	339
FUTURE DEVELOPMENTS	363
W.K.M. Astley: Gulf Area Oil Companies Mutual Aid Organization (GAOCMAO) Current Programme and Future Prospects	365
K. Wilson: Policies on the Use of Dispersants - the Role of Toxicity Testing Programmes for Oil Dispersant Chemicals	371
ANNEX: Information about the authors	389

SESSION I: GENERAL OVERVIEW

1. Kuwait Action Plan - Overall Concept and Progress Made  
A. Al-Zaidan
2. Statistical Analysis of Oil Pollution in the Kuwait Action Plan Region and the Implications of Selected World-Wide Oil Spills to the Region  
R. Golob and E. Brus
3. Effects of Oil-Industry Related Pollution on Marine Resources of the Kuwait Action Plan Region  
A. Nelson-Smith
4. Biological Impact and Effects on Fisheries of Oil Spill in Bahrain, August-September 1980  
O. Linden



KUWAIT ACTION PLAN - OVERALL CONCEPT AND PROGRESS MADE

by  
A. Al-Zaidan

Regional Organization for the Protection of the Marine Environment,  
Safat, Kuwait

Ministers, distinguished delegates and observers, ladies and gentlemen, it gives me great pleasure to talk to you on the Kuwait Action Plan, its concept and overall progress made.

The Region referred to in the Kuwait Action Plan is a land-locked body of shallow sea-water, 1000 km long and 300 km wide, with coastlines on Bahrain, Iran, Iraq, Kuwait, Oman, Qatar, Saudi Arabia, and the United Arab Emirates. It is regarded as having one of the most fragile and endangered ecosystems in the world and is deeply affected by severe sources of pollution. The rapid industrialization and urbanization of the States of the Region have drastically changed its socio-economic structure, and it is quite clear that the extensive utilization of the coastal areas for various development activities has adversely affected the marine environment, causing great concern.

The Governing Council of the United Nations Environment Programme, at its third session held in 1975, recognized this as a concentration area in which UNEP, in close collaboration with other relevant agencies of the United Nations system, would attempt to fulfil its catalytic role in assisting States of the Region to develop and implement, in a consistent manner, an Action Plan commonly agreed upon.

The Kuwait Regional Convention for Co-operation on the Protection of the Marine Environment from Pollution, referred to as the KUWAIT ACTION PLAN, entered into force on 30 June 1979 and was a result of serious and hard efforts recognized by the Governments concerned and the United Nations bodies, to make such interim arrangements as might be required until the establishment of the Regional Organization for the Protection of the Marine Environment. Thus, the Interim Secretariat was officially inaugurated in Kuwait on 7 July 1980.

The staff consists of an Acting Co-ordinator, a marine scientist (not yet appointed), one economist, an administrative officer and secretarial staff. Prior to the opening of the Interim Secretariat office in Kuwait, the programme had been formulated and administered at the Regional Seas Programme Activity Centre (RS/PAC) of UNEP, in Geneva, under the guidance of Dr. S. Keckes, Director, Dr. R. Helmer, Deputy Director, and Mr. Khamis Al-Nahdi (Saudi Arabia) Acting Co-ordinator, from whom I took over in June of this year. The RS/PAC continues to guide and is available for consultation on all programme matters concerning the Kuwait Action Plan.

In November 1979, forty-six experts from the eight KAP countries met in Kuwait. They had before them the draft programme document setting forth the environmental assessment and management activities to be carried out within the Action Plan. The document described 17 specific projects which the experts revised and amended, as they felt necessary. They divided the projects into thematic groups and assigned them order of priority so that work on certain of them could be started immediately.

The first group of projects, to generate information for use as a basis for subsequent work, included surveys of national capabilities related to the Action Plan (such as the status of institutions, manpower and equipment available in the Region); the status of meteorological studies related to the transport and distribution of oil; a survey of land-based sources of pollution of the region, and the organizing of a Workshop on marine pollution from ships.

The gathering of baseline information called for in these projects was greatly facilitated by the visit of an inter-disciplinary mission to the Region between March and July 1980. The mission spent about a week in each of the eight countries, making direct contact with the various government agencies involved in environmental matters. This was considered to be the most efficient means of gathering the required information.

A working group of regional experts met in Kuwait from 5-7 July 1980 to review the results of the mission and to determine the operational details of a second group of projects. This second group of projects constituted a selected field giving a comprehensive picture of how serious pollution in the Region is and what the effects are likely to be. Included in this group are (1) baseline studies on the sources, transport and distribution of oil and petroleum hydrocarbons - (2) physical, chemical and biological oceanography as related to the transport, distribution and fate of oil as a pollutant - (3) assessment of the magnitude of pollutants affecting human health and marine ecosystems - (4) the productivity and distribution of plankton - (5) ecological studies of intertidal and subtidal zones - and (6) assessment of geological processes related to the fate and impact of pollutants. The experts also considered the feasibility of an oceanographic cruise around the Region to collect data.

The remaining projects largely relate to environmental management and include the assessment of the environmental impact of development activities in the Region, the building up of engineering capabilities related to the environmental management, co-ordination of marine and land transport and establishing of guidelines for coastal development. Still others deal with the biology of commercially important species of marine organisms and assessment of their stocks, management of living resources, co-ordination of water management policies and strengthening of public health services.

Work on the latter projects can only begin after the first annual review meeting of the States of the Region. This was scheduled to take place in Kuwait from 25-30 October of this year, but due to the prevailing circumstances in the Region, several of the KAP Region Governments requested a postponement of the meeting for the time being.

At the end of September I visited the countries of the KAP Region. Unfortunately, I was unable to visit either Iran or Iraq due to the prevailing situation, but I hope to visit these countries when conditions are more favourable. The purpose of my trip was to hand over to the focal points the working documents prepared for the meeting, brief them on the preparatory work for the meeting and what was expected from the government experts afterwards. My discussions were most fruitful; certain useful points were noted for consideration at the meeting and it was clear to me that there was a similarity of views between the parties concerned and an indication of identical approaches in the implementation of the projects.

The Regional Seas Programme Activity Centre, in Geneva, in collaboration with the United Nations Agencies concerned, is now preparing a pilot programme for implementation in 1981 and it is hoped that this will soon be ready for submission to the Governments of the Region, for their approval. Once this approval has been received, implementation of the programme will commence.

One project remains outside the grouping I have just described, because it is considered as an essential part of all Action Plan activities. This project calls for regular and systematic public awareness campaigns aimed at enhancing environmental awareness and understanding throughout the Region. Proposals and data for such campaigns are under preparation. The campaigns will stress not only the importance of protection of the marine environment and coastal areas of the Region, but the more novel idea that this protection can actually be an asset to development.

A meeting of experts was held in Bahrain from 2-5 December 1979, on the establishment of the Marine Emergency Mutual Aid Centre (MEMAC), for the Kuwait Action Plan Region. The Centre will be established in accordance with a resolution

of the 1978 Kuwait Regional Conference of Plenipotentiaries on the Protection and Development of the Marine Environment and Coastal Areas, and the Protocol concerning Regional Co-operation in Combating Pollution by Oil and other Harmful Substances in Cases of Emergency (also adopted at the 1978 Conference).

The meeting was held to review the objectives and functions of the Centre and determine how best to establish the Centre quickly and effectively. Recommendations of the meeting were to have been presented to the first meeting of the Council of the Regional Organization for the Protection of the Marine Environment (consisting of the contracting parties to the Kuwait Convention) scheduled for 1980, but which has not yet been held. There was a consensus among the experts that MEMAC should be a relatively autonomous operation, especially since its purpose will be to deal with emergency situations. It was also considered that the Director of MEMAC should have a fairly free hand in order to respond quickly and efficiently to a given situation, since flexibility and independence are essential if centre such as this is really going to be effective.

Another theme which was consistently stressed as being one of the Centre's major tasks, was the training of personnel, both within and outside the Region, to deal with pollution emergencies.

Following the recent unfortunate oil spill in the Region, urgent consultations took place between the Interim Secretariat and the focal points of Bahrain, the United Arab Emirates, Qatar, Saudi Arabia and Oman. These resulted in the Interim Secretariat being requested, by Bahrain, to convene an urgent meeting in order to discuss the establishment of MEMAC. After consulting with RS/PAC and UNEP headquarters, I paid a short visit to Bahrain in order to clarify UNEP's role at such a meeting. The Governments concerned clearly identified the establishment and operation of MEMAC as a responsibility of the Regional Marine Environment Council and that oil pollution projects were clearly a priority task for MEMAC. Further steps for the establishment of MEMAC should, therefore, be conceded by the Council at its first meeting, the date of which has yet to be announced.

In conclusion, I would like to express my deep gratitude to those who have made this Workshop possible, especially the Government of Bahrain, which has most kindly provided the Workshop with excellent facilities that will surely contribute to the Workshop's success. Our gratitude also goes to all the participants from Governments who have shown deep concern with oil pollution problems in the Region and whose co-operation and support have provided valuable professional and technical input to the Workshop. I would also like to congratulate IMO, whose efforts over the past year, in co-operation with UNEP, have resulted in bringing about this meeting.

I look forward to the continued co-operation of all concerned and am confident that our united efforts will greatly contribute to the quality of human life and afford a reprieve to the environment of the Region.

STATISTICAL ANALYSIS OF OIL POLLUTION IN THE KUWAIT ACTION PLAN REGION  
AND THE IMPLICATIONS OF SELECTED WORLD-WIDE OIL SPILLS TO THE REGION

by  
R. Golob and E. Brus

Center for Short-lived Phenomena,  
Cambridge, Mass., USA

ABSTRACT

This paper estimates that, during 1979, a total of about 144,000 metric tonnes of oil polluted the Kuwait Action Plan (KAP) Region and that, during the 10 years from 1980 to 1989, more than 1.5 million metric tonnes will pollute the Region. These totals include estimates for oil pollution from the following sources: natural seeps; offshore exploration and production; transportation losses, including terminal operations and both accidental and operational discharges; coastal refineries; atmospheric fall-out; coastal municipal wastes and coastal non-refinery industrial wastes; urban run-off; and river run-off. Among these sources, transportation losses contributed more than 58 per cent of the total amount in 1979, and offshore exploration and production contributed about 22 per cent. According to these estimates, oil pollution in the KAP Region represented 3.1 per cent of the total oil pollution in the world, thereby contributing 47 times the average estimated amount for a marine environment of similar surface area.

## INTRODUCTION

The KAP Region is undergoing the world's most rapid economic development. The average investment per kilometre of coastline in the Region ranges between \$20 million and \$40 million (Neuman, 1979). In terms of oil production, the countries in the Region accounted for 33.8 per cent of the total world oil production in 1979, while consuming only 2.4 per cent of the total oil consumed world-wide (British Petroleum Co., 1980). The countries exported about 60 per cent of all the oil transported by ships around the world, with about 100 ships passing through the Strait of Hormuz every day last year. With regard to offshore production, the Region has perhaps the highest ratio of oil produced per producing well of any area in the world.

Given the large volume of oil produced and transported in the KAP Region, this paper identifies the major sources of oil pollution in the Region and estimates the amount of oil pollution from each source. The paper also shows that the magnitude of oil pollution will continue to increase in the Region during the next decade. In addition, it focuses attention on the need to establish a regional spill data base so as to develop baseline statistics for future studies.

## INTERNATIONAL SUMMARY OF SPILL STATISTICS

The amount of oil spilt or burnt in major incidents world-wide during 1979 increased 56 per cent over the corresponding amount lost in 1978, according to the Oil Spill Intelligence Report. In addition, the amount of oil spilt or burnt in major tanker accidents during 1979 increased 42 per cent over the corresponding amount lost in 1978. Major incidents were defined as those involving the loss to spillage or fire of more than 20,000 gallons (300 gallons = 1 metric tonne) of oil.

In 1979, more than 328 million gallons of oil were lost in 159 major incidents world-wide in which the amount of oil spilt or burnt was known. A total of 51 other major incidents was recorded in which the amount of oil spilt or burnt was not known. In the total of 210 incidents recorded in the Oil Spill Intelligence Report during 1979, more than 250 people were killed or reported missing, and over 50,000 birds and 270,000 fish were killed. About 10 per cent of the incidents involved the loss of more than 1 million gallons each, and those incidents contributed about 95 per cent of the total amount lost in 1979.

In 1978, about 210 million gallons of oil spilt or burnt in 109 major incidents in which the amount spilt or burnt was known. A total of 32 other major incidents were recorded in which the amount spilt or burnt was not known. In the 141 major incidents recorded in the Oil Spill Intelligence Report during 1978, at least 138 people were killed or reported missing.

About 73 per cent of the oil lost to spillage and fire in 1979 occurred in the following five incidents: 1) the blow-out of the Ixtoc 1 oil well in the Bahia de Campeche, Mexico, on 3 June, and the subsequent spillage of more than 134 million gallons from the well in 1979. In total, the Ixtoc 1 spilt at least 140 million gallons of oil before it was capped on 23 March 1980, 295 days after the initial blow-out. The Ixtoc 1 lost more than twice the record amount involved in the Amoco Cadiz incident; 2) the rupture of a storage tank in Forcados, Nigeria, on 6 July and the loss of about 24 million gallons; 3) the collision between the tanker Atlantic Empress and the tanker Aegean Captain on 19 July north of Tobago in the Caribbean

Sea, and the loss of about 43 million gallons to spillage and fire; 4) the collision between the tanker Burmah Agate and a freighter on 1 November off Galveston, Texas, and the loss of nearly 11 million gallons to spillage and fire during the following two months; and 5) the collision between the tanker Independenta and a freighter on 15 November in the Bosphorus Strait, and the loss of nearly 29 million gallons during the following six weeks.

During 1979, almost 132 million gallons spilt or burnt in 38 tanker accidents in which the amount lost was known. A total of 17 other tanker spills were recorded in which the amount lost was not known. During 1978, however, about 93 million gallons spilt or burnt in 19 tanker accidents in which the amount lost was known. The loss from the Atlantic Empress contributed about 33 per cent of the total amount of oil spilt or burnt in tanker incidents in 1979. The 68 million gallons that spilt from the Amoco Cadiz in March 1978 contributed about 74 per cent of the amount spilt or burnt in tanker accidents that year. In 1979, about 127 million gallons were lost in 11 tanker incidents involving the loss of at least 1 million gallons, and those incidents accounted for 96 per cent of the oil spilt or burnt in tanker incidents that year. In 1978, about 91 million gallons were lost in 6 tanker incidents of greater than 1 million gallons, accounting for almost 98 per cent of the total amount spilt or burnt in tanker incidents that year.

These statistics provide an accurate order of magnitude estimate for the amount of oil lost in major incidents world-wide during 1979. They do not include oil pollution from such sources as minor accidental spills, river run-off, operational discharges, and atmospheric fall-out. An analysis of the major spill incidents shows that significant pollution resulted from oil exploration, production, refining, and transportation activities. We expect that these spill statistics will increase in quality as countries world-wide begin to establish spill reporting systems and as the technology develops to detect and monitor spills.

#### REVIEW OF STUDIES ON OIL POLLUTION STATISTICS

The U.S. National Academy of Sciences (1975) and Beyer and Painter (1977) have published studies on the sources and amounts of oil in the marine environment. These studies have calculated estimates for the magnitude of oil pollution world-wide from the following sources: natural seeps; offshore exploration and production; transportation losses, including terminal operations and both accidental and operational discharges; coastal refineries; atmospheric fall-out; coastal municipal wastes and coastal non-refinery industrial wastes; urban run-off; and river run-off.

##### National Academy of Sciences Study

The National Academy of Sciences (NAS) report is an outgrowth of a workshop that the Ocean Affairs Board of the National Research Council-National Academy of Sciences organized in May 1973 to discuss the inputs, fates, and effects of petroleum in the marine environment. The workshop received support from the U.S. Environmental Protection Agency, the U.S. Coast Guard, the Office of Naval Research, the Rockefeller Foundation, and the American Chemical Society. The workshop investigated the sources and amounts of petroleum inputs into the marine environment, evaluated the methods for chemically analysing hydrocarbons, and examined the fates and effects of petroleum pollution. Sixty scientists and engineers from research institutions, government agencies, and industrial organizations participated in the workshop. The NAS report emphasized the "paucity

of firm data on petroleum in the sea" and stated that, as a result, "many of the conclusions are based on judgment rather than fact." The study stressed, however, the "sincerity of the panels, the overall balance of the workshop membership, and the efforts made to minimize the uncertainties introduced by these judgment factors." With these limitations in mind, we summarize below the NAS estimates of oil pollution world-wide (table 1).

TABLE 1  
 NAS Estimated Inputs of Petroleum Hydrocarbons  
 in the Marine Environment during the Early 1980s

<u>Source</u>	<u>Amount per Annum Estimate in Tonnes</u>	<u>Percent of Total</u>
Natural Seeps	600,000	13.1
Offshore Production	200,000	4.4
Tanker Transport	700,000	15.3
Non-tanker Accidents	100,000	2.2
Coastal Refineries	20,000	0.4
Atmospheric Fall-out	600,000	13.1
Coastal Municipal Wastes & Coastal Non-refinery Wastes	450,000	9.9
Urban Run-off	300,000	6.6
River Run-off	1,600,000	35.0
<hr/> TOTAL	<hr/> 4,570,000	<hr/> 100.0

The NAS report estimated that, in the 1980s, approximately 4,570,000 metric tonnes of oil would enter the world's oceans per year. Natural seeps on the ocean floor would release 600,000 tonnes per year, or 13.1 per cent of the total. According to the NAS, offshore drilling and production operations would contribute about 200,000 tonnes per year, or 4.4 per cent of the total. Of this amount, an estimated 50,000 tonnes per year would be lost through minor spills of less than 50 barrels and through discharges of oily brines during normal drilling and producing operations, and about 150,000 tonnes per year would be lost during major accidents such as well blow-outs and pipeline ruptures involving spills of more than 50 barrels.

Transportation-related releases would account for about 800,000 tonnes per year, or approximately 17.5 per cent of the total volume of marine oil pollution. This amount would include the following: 1) 200,000 tonnes released from tankers during normal operations, such as tanker washings and dry docking; 2) 3,000 tonnes spilt at terminals during ship-to-shore transfers; 3) 300,000 tonnes lost during bilge and bunkering operations; 4) 200,000 tonnes spilt during tanker accidents, including 50,000 tonnes lost during a single catastrophic tanker incident; and 5) 100,000 tonnes lost during non-tanker accidents.

The report projected that coastal refineries would discharge about 20,000 tonnes per year, or 0.4 per cent of the total marine oil pollution, while coastal municipal wastes and coastal non-refinery industrial wastes would contribute an additional 450,000 tonnes, or 9.9 per cent of the total. The NAS also estimated



that oil spillage on streets and pavements and other petroleum run-off into urban storm drainage systems would contribute about 300,000 tonnes per year, or about 6.6 per cent of the total oil input into the marine environment.

According to the NAS report, the remainder of the oil in the oceans would come from atmospheric fall-out and river run-off. The report projected that the atmospheric fall-out would contribute about 600,000 tonnes of oil, or 13.1 per cent of the total, and rivers would carry into the oceans each year about 1,600,000 tonnes of oil, or 35.0 per cent of the total.

#### Beyer and Painter Study

A.H. Beyer and L.J. Painter, two Standard Oil Co. of California researchers, presented a paper entitled "Estimating the Potential for Future Oil Spills from Tankers, Offshore Development, and Onshore Pipelines" at the 1977 U.S. Conference on the Prevention and Control of Oil Spills. The paper summarized historical spill statistics and described techniques and equations for estimating the number and size of spills from tankers, offshore development facilities, and cross-country pipelines.

In the paper's introduction, Beyer and Painter cautioned that the paper did not attempt to quantify the reduction in future spillage that would probably result from "continuing improvements in technology, operating procedures, safety methods, and environmental protection regulations." They cited a Western Oil and Gas Association estimate that such improvements would reduce the future spill rates of offshore development operations and tankers by 25 to 50 per cent. As a result, Beyer and Painter concluded that their techniques would provide worst-case estimates.

Based on their analysis of 522 tanker spills occurring between 1969 and 1972, Beyer and Painter derived the following data on tanker spills within 80 kilometres of land: 1) the average coastal spill rate is 87 tonnes per million tonnes transported; 2) 0.92 spill take place every 1,000 port calls; and 3) the average spill size is 7,124 barrels. In addition, based on their analysis of the casualty data, Beyer and Painter made the following conclusions about all tanker spills: 1) groundings, collisions, and structural failures have been the most frequent causes of tanker spills; 2) 81 per cent of tanker spills occurred within 80 kilometres of land; and 3) the average spill size at sea, where structural failures often result in a total cargo loss, was about three times the average spill size within 80 kilometres of land.

Beyer and Painter also analysed spills resulting from well blow-outs, pipeline accidents, platform fires, natural phenomena, and platform overflows and malfunctions. Based on a study of 48 offshore development spills involving more than 50 barrels from 1966 to 1975, they concluded that the average spill rate for offshore petroleum development activity is 72 tonnes per million tonnes of oil and condensate produced. According to Beyer and Painter, 15 pipeline accidents resulted in the spillage of 200,861 barrels, or an average of 13,391 barrels per spill. A single pipeline incident, however, accounted for more than 160,000 barrels lost. Two well blow-outs resulted in the loss of an estimated 77,500 barrels, and the Santa Barbara, California blow-out in 1969 accounted for 75,000 barrels of that total.

## METHODOLOGY FOR SPILL ESTIMATES

In calculating the amount of oil pollution entering the KAP Region on an annual basis, we have used data contained in the NAS report and the Beyer and Painter paper and have adapted the methodology developed by the Research Planning Institute (RPI) in Columbia, South Carolina, to make a similar estimate in 1977. We have also used data from the following sources: 1) British Petroleum Co., Offshore Magazine, and the U.S. Department of Energy for statistics on oil production, consumption, refining, and export in individual countries and on a regional and world-wide basis; 2) the U.S. Census Bureau for world-wide population figures; and 3) The Times Atlas of the World for geographical data.

### Terminology and Assumptions

The term "KAP Region" or "Region" refers to the marine environment and the coastal areas of Bahrain, Iran, Iraq, Kuwait, Oman, Qatar, Saudi Arabia, and the United Arab Emirates, as defined in the "Final Act of the Kuwait Regional Conference of Plenipotentiaries on the Protection and Development of the Marine Environment and the Coastal Areas." Whenever possible, we attempted to compile oil statistics and population figures for individual countries in the Region and to base our projections on these figures. In some instances, however, the only precise information was available on a regional basis only. Consequently, we use the term "Middle East" to describe data for oil production, consumption, refinery throughputs, and exports from Israel, Jordan, Lebanon, the Syrian Arab Republic, and Yemen, in addition to the eight countries in the KAP Region. When we discuss offshore production for the Region, we have assumed that the production takes place entirely within the marine environment and the coastal areas of those countries. In the case of exports, almost 100 per cent of all oil exported from Middle East countries originates in the KAP Region, and we have considered the export figures for the Region to be equivalent to the export figures for the Middle East.

In our calculations, we have reduced Middle East consumption and refinery capacity statistics to reflect actual levels in the KAP Region because we have assumed that oil consumption for individual nations is proportional to population and because several Middle East nations outside the Region have significant refinery throughputs.

For consistency in our calculations, we have converted all final amounts into metric tonnes. When our original data sources have provided amounts in barrels, we have converted the barrels into tonnes, using average densities of 7.314 barrels per tonne for crude oil, and 7.392 barrels per tonne for all exports, including both crude oil and products. We have included spill estimates to the nearest tonne, in part to make our calculations easy for the reader to follow, and in part to maintain the precision of the various spill estimates. For example, if we rounded our estimates to the nearest 1,000 tonnes, we would reduce our estimate for pollution from coastal refineries by a factor of almost 35 per cent, and our estimate for atmospheric fall-out from 396 tonnes per year to zero.

## ESTIMATES FOR OIL POLLUTION

### Natural Seeps

Wilson et al. (1974) subdivided the world's continental margins into regions of low, moderate, and high seepage potential and assigned the following average seepage

rates to those regions respectively: 0.1, 3, and 100 barrels per day per 1,000 square miles (1 square mile = 2.59 square kilometres). Previous studies indicated that the sea area of the Region has a moderate seepage potential and covers a surface area of 92,278 square miles (Sverdup, et al., 1942). Based on these data, the amount of oil entering the Region each year from natural seeps would total 101,044 barrels per year:

$$\frac{365 \text{ days}}{\text{year}} \times \frac{3 \text{ barrels}}{(\text{day})(1,000 \text{ square miles})} \times \frac{92,278 \text{ square miles}}{\text{year}} = 101,044 \text{ barrels}$$

or 13,815 tonnes per year:

$$\frac{101,044 \text{ barrels}}{\text{year}} \times \frac{\text{tonnes}}{7.314 \text{ barrels}} = \frac{13,815 \text{ tonnes}}{\text{year}}$$

#### Offshore Production

RPI used the following three methods developed by the NAS (1975), Beyer and Painter (1977), and Devanney and Stewart (1974) to estimate the amount of oil entering the KAP Region from offshore platforms and pipelines. We have used a similar approach with updated statistics.

Method 1: The NAS estimated that the average oil loss from minor spills involving less than 50 barrels and from briny discharges totals between 8.6 tonnes per million tonnes produced and 32 tonnes per million tonnes produced. The NAS also calculated that, for spills greater than 50 barrels, the total oil loss would amount to approximately 140 tonnes per million tonnes produced. The statistics department of Offshore Magazine estimated that the total 1979 offshore production in the KAP Region amounted to 4,806,000 barrels per day, or 239,840,000 tonnes per year:

$$\frac{4,806,000 \text{ barrels}}{\text{day}} \times \frac{365 \text{ days}}{\text{year}} \times \frac{\text{tonnes}}{7.314 \text{ barrels}} = \frac{239,840,000 \text{ tonnes}}{\text{year}}$$

Based on 1979 production figures, we calculated the amount of oil entering the Region from the following offshore production sources:

a) Briny discharges and spills involving less than 50 barrels:

$$\text{Low value: } \frac{8.6 \text{ tonnes spilt}}{\text{million tonnes produced}} \times \frac{239.840 \text{ million}}{\text{tonnes produced}} = \frac{2,063 \text{ tonnes}}{\text{spilt}}$$

$$\text{High value: } \frac{32 \text{ tonnes spilt}}{\text{million tonnes produced}} \times \frac{239.840 \text{ million}}{\text{tonnes produced}} = \frac{7,675 \text{ tonnes}}{\text{spilt}}$$

b) Spills involving more than 50 barrels:

$$\frac{140 \text{ tonnes spilt}}{\text{million tonnes produced}} \times \frac{239.840 \text{ million}}{\text{tonnes produced}} = \frac{33,578 \text{ tonnes}}{\text{spilt}}$$

Therefore, the total estimated spillage from offshore production activities has an average value of 38,447 tonnes:

$$\text{Low value: } 2,063 \text{ tonnes} + 33,578 \text{ tonnes} = 35,641 \text{ tonnes}$$

High value: 7,675 tonnes + 33,578 tonnes = 41,253 tonnes

Average value:  $\frac{35,641 \text{ tonnes} + 41,253 \text{ tonnes}}{2} = 38,447 \text{ tonnes}$

Method 2: Beyer and Painter estimated that the average spill rate for offshore development activities is 72 tonnes spilt for every million tonnes produced. Using Beyer and Painter methodology, we have deduced that the amount spilt in 1979 from offshore activities is approximately 17,268 tonnes:

$\frac{72 \text{ tonnes spilt}}{\text{million tonnes produced}} \times 239.840 \text{ million tonnes produced} = 17,268 \text{ tonnes spilt}$

Method 3: Devanney and Stewart estimated that the amount of oil lost from offshore platforms is 60 tonnes per million tonnes produced, and that the spillage from offshore pipelines averages 110 tonnes per million tonnes produced. Using these estimates with 1979 offshore production figures, we have calculated the following:

a) Losses from offshore platforms:

$\frac{60 \text{ tonnes spilt}}{\text{million tonnes produced}} \times 239.840 \text{ million tonnes produced} = 14,390 \text{ tonnes spilt}$

b) Losses from offshore pipelines:

$\frac{110 \text{ tonnes spilt}}{\text{million tonnes produced}} \times 239.840 \text{ million tonnes produced} = 26,382 \text{ tonnes spilt}$

The total estimated spillage from platforms and pipelines is 40,772 tonnes:

14,390 tonnes + 26,382 tonnes = 40,772 tonnes

Since the three methods exhibit a wide variation in the estimated amount of oil spilt into the Region from offshore operations, we believe that the best final estimate would be an average of the value derived from the three methods, or 32,162 tonnes:

$\frac{38,447 \text{ tonnes (NAS)} + 17,268 \text{ tonnes (Beyer and Painter)} + 40,772 \text{ tonnes (Devanney and Stewart)}}{3} = 32,162 \text{ tonnes spilt}$

#### Tanker Transportation

During the transportation of oil in tankers, oil pollution may result from either tanker accidents or operational oil discharges. Based on tanker casualty data for the period of 1969 to 1972, Beyer and Painter used the following variables to estimate the average amount of oil spilt from tanker accidents within 80 kilometres of shore: 1) volume of oil transported, and 2) number of port calls.

As mentioned earlier, Beyer and Painter calculated that the average spillage within 80 kilometres of shore as a result of tanker accidents would be 87 tonnes per million tonnes transported. We used the following reasoning to calculate a spill estimate for nearshore tanker accidents in the KAP Region alone: British Petroleum

Co. (1980) estimated that, during 1979, the Middle East nations exported approximately 1,009 million tonnes of oil. In our estimates of spill incidents, we have assumed that almost all of the oil exported from the Middle East nations originated in the KAP Region and that tankers transported all of the oil out of the Region. If we assume that all the nearshore oil pollution associated with tankers carrying oil from the KAP Region actually occurred in the Region, the total oil spillage from tanker casualties within 80 kilometres of the shores in the Region during 1979 would have totalled 87,783 tonnes:

$$\frac{87 \text{ tonnes spilt}}{\text{million tonnes exported}} \times \frac{1,009 \text{ million tonnes}}{\text{tonnes exported}} = 87,783 \text{ tonnes spilt}$$

In actual fact, however, tankers carrying oil from the Region pass within 80 kilometres of the shore at the following point locations: the point of origin, the point of destination, intermediate port calls, and the nearshore portions of shipping lanes. For our calculations, we have assumed that tankers carrying oil from the Region pass within 80 kilometres of the shore at the following three points during a voyage:

- 1) during passage through the KAP Region from the point of origin;
- 2) at an intermediate port call or while rounding a continent; and
- 3) while approaching the point of destination.

We have assumed that nearshore casualties will have an equal distribution at these three locations and that one-third of the nearshore accidental spillage, amounting to 29,261 tonnes, will occur in the Region:

$$\frac{87,783 \text{ tonnes}}{3} = 29,261 \text{ tonnes}$$

According to Beyer and Painter, world-wide casualty data for the period 1969 to 1972 indicate that the average spill rate is 0.92 nearshore spill per 1,000 port calls and that the average spill size is 7,124 barrels per spill. Although we have not located port call data in the KAP Region for 1979, the RPI study indicates that, in 1976, tankers made 10,114 port calls at Region ports, accounting for exports of 1,033 million tonnes (BP, 1980) of crude oil and refined products in 1976. Assuming the same tanker population in the Region during 1979 as during 1976, and assuming a proportional decrease in tanker port calls for transporting the 1,009 million tonnes (BP, 1980) exported from the Middle East during 1979, we have calculated that tankers would have made approximately 9,879 port calls in the Region during 1979:

$$\frac{1,009 \text{ million tonnes}}{1,033 \text{ million tonnes}} \times \frac{10,114 \text{ port calls (1976)}}{\text{exported (1976)}} = 9,879 \text{ port calls (1979)}$$

Using Beyer and Painter's port call estimate for spillage, a total of 9,879 port calls would correspond to a total spillage of 8,759 tonnes:

$$\frac{0.92 \text{ spills}}{1,000 \text{ port calls}} \times \frac{9,879 \text{ port calls}}{\text{calls}} \times \frac{7,124 \text{ barrels}}{\text{barrels}} \times \frac{\text{tonne}}{7.392 \text{ barrels}} = 8,759 \text{ tonnes}$$

We believe that, compared to the estimate based on port calls, the estimate based on a spill rate of 87 tonnes spilt per million tonnes transported has greater accuracy because a single major incident will probably spill more oil than the entire port call estimate of 8,759 tonnes. For example, in 1972, the collision between the 120,300-DWT South Korean tanker Sea Star and the tanker Horta Barbosa resulted in the spillage of more than 100,000 tonnes of oil into the Gulf of Oman. This incident accounted for nearly 13 times the estimate for average annual spillage based on the port call estimate.

#### Tanker Cleaning and Ballasting

According to the NAS, Load On Top (LOT) procedures could eliminate 90 per cent of the operational discharges associated with tanker cleaning and ballasting. Tankers using LOT procedures retain cargo tank washings and oily ballast water on board to separate out the oil from the water for incorporation into the next shipment. When tankers do not use LOT measures, they typically discharge about 0.35 per cent of their carrying capacity during their ballast voyage. NAS estimated that, when tankers use LOT, the procedure reduces the pollution by 90 per cent and that therefore a typical discharge from such tankers would contain only 0.035 per cent of the tanker's cargo capacity.

Oil industry statistics indicate that, during the mid-1970s, approximately 80 per cent of all tankers used LOT, with the remainder discharging their tank washings and ballast water directly into the ocean. If we assume that the same ratio of LOT usage applies for tankers transiting the KAP Region, the 80 per cent of the tankers that use LOT would discharge a total of 282,520 tonnes of oil while carrying oil from the Region:

1,009 million X (0.035 per cent loss) X (80 per cent) = 282,520 tonnes  
tonnes exported

The 20 per cent of the tankers that do not use LOT would discharge 706,300 tonnes:

1,009 million X (0.35 per cent loss) X (20 per cent) = 706,300 tonnes  
tonnes exported

The total oil loss from tankers carrying oil from the KAP Region would amount to 282,520 tonnes plus 706,300 tonnes, or 988,820 tonnes. Since tankers carrying oil to North America, Europe, and Asia travel about 5 to 10 per cent of their total voyage distances in the confines of the Region, only about 5 to 10 per cent of the total loss would occur in the Region if the tankers distributed their tank cleaning and ballasting activities evenly along their routes. Since tanker captains would probably be more likely to release ballast water some distance from land, away from close scrutiny by national and international maritime authorities, we have estimated that only about 5 per cent of the total ballasting and tank cleaning discharges, amounting to approximately 49,441 tonnes of oil, takes place in the Region.

#### Terminal Operations

According to Brummage (1973), the average loss rate at the Milford Haven, U.K. tanker terminal was 1.1 tonnes per million tonnes throughput during nine years of operation. For a similar port in Portland, Maine, the loss rate was about 2.2 tonnes per million tonnes throughput. We applied these two spill rates to the KAP Region and used the export total of 1,009 million tonnes in 1979 (BP, 1980) as the terminal throughput. Our calculations indicate an estimated range of between 1,110

and 2,220 tonnes as the total oil loss from terminals in the Region during 1979:

$\frac{1.1 \text{ tonnes spilt}}{\text{million tonnes throughput}} \times 1,009 \text{ million tonnes throughput} = 1,110 \text{ tonnes spilt}$

$\frac{2.2 \text{ tonnes spilt}}{\text{million tonnes throughput}} \times 1,009 \text{ million tonnes throughput} = 2,220 \text{ tonnes spilt}$

Since countries in the KAP Region have somewhat less strict environmental laws than does either the U.S. or the U.K., and since historical data indicate that individual terminal spills as large as 5,000 tonnes have occurred in the Region during the past decade, we have estimated that the annual loss from terminal operations is greater in the Region than at either Milford Haven or Portland. If we assume a spillage rate of 1.5 times the average spillage rate at Portland, or 3.3 tonnes spilt per million tonnes transported, then our estimate for total oil discharges from terminals in the Region would be 3,330 tonnes:

$\frac{3.3 \text{ tonnes spilt}}{\text{million tonnes throughput}} \times 1,009 \text{ million tonnes throughput} = 3,330 \text{ tonnes spilt}$

#### Total Tanker-related Losses

In summary, we calculated that tanker-related losses amounted to a total of 82,032 tonnes:

Tanker casualties	29,261 tonnes
Tanker cleaning and ballasting	49,441 tonnes
Terminal operations	3,330 tonnes
	<hr/>
Total :	82,032 tonnes

#### Non-tanker Accident Losses

The NAS estimated that non-tanker accidents contribute approximately 100,000 tonnes of oil each year into the marine environment world-wide. We believe that a reasonable estimate of the oil lost through non-tanker accidents in the KAP Region may be based on the total level of industrial development in both the coastal and non-coastal areas of the countries in the Region. We have further assumed that the level of industrial activity may be linked directly to the level of oil consumption in those areas and that oil consumption may be related directly to total population.

According to the U.S. Census Bureau, the population of the countries in the KAP Region was 59,941,000, or 71.6 per cent of the Middle East population of 83,714,000. If we assume that the KAP Region consumed oil at the same rate per capita as the entire Middle East, then the KAP Region would have consumed 71.6 per cent of the 74.8 million tonnes (BP, 1980) of oil consumed in the Middle East in 1979, or 53.56 million tonnes.

If the nations in the Region consume 53.56 million tonnes of the estimated 3,119.6 million tonnes of oil consumed world-wide in 1979 (BP, 1980), we estimate that 1,717 tonnes of the 100,000 tonnes of oil lost world-wide from non-tanker accidents is spilt in the Region:

$\frac{53.56 \text{ million tonnes}}{3,119.6 \text{ million tonnes}} \times 100,000 \text{ tonnes spilt} = 1,717 \text{ tonnes spilt}$

### Coastal Refineries

The NAS reported that refineries using a gravity separation/dissolved air flotation system may reduce the oil content of refinery discharges to about 20 parts per million. According to RPI, refineries in the Region had a total throughput of 66.2 million tonnes, or 57.56 per cent of the total 1976 Middle East refinery throughput of 115 million tonnes (BP, 1980). If we assume the same proportion of 57.56 per cent for 1979, when the total Middle East refinery throughput reached 117 million tonnes, refineries in the Region would account for 67.35 million tonnes throughput:

$$57.56 \text{ per cent} \times 117 \text{ million tonnes} = 67.35 \text{ million tonnes}$$

With a discharge rate of 20 parts per million, a 67.35-million-tonne throughput would lead to a discharge of 1,347 tonnes:

$$\frac{20 \text{ tonnes discharged}}{\text{million tonnes throughput}} \times 67.35 \text{ million tonnes throughput} = 1,347 \text{ tonnes discharged}$$

### Atmospheric Fall-out

The NAS estimated that oil pollution from atmospheric fall-out will total 600,000 tonnes in the early 1980s, the same figure given for 1973 when world-wide oil consumption was only about 80 per cent of current levels. This estimate of no change was probably based on the assumption that increasingly strict hydrocarbon emission standards in industrialized countries would balance out any increase in pollution which might otherwise occur from increased petroleum consumption. Our estimates for atmospheric fall-out in 1979 and during the 1980s make a similar assumption. The surface area of the Region's marine environment totals 92,278 square miles, or 0.066 per cent of the total surface area of the world's oceans and lakes, which is 139,660,400 square miles. If the 600,000 tonnes from atmospheric fall-out were distributed equally over the world's lakes and oceans, then pollution from atmospheric fall-out over the sea area of the Region would total 0.066 per cent of the total, or about 396 tonnes per year.

### Coastal Municipal Wastes and Coastal Non-refinery Industrial Wastes

The NAS study estimated that coastal municipal wastes and coastal non-refinery industrial wastes in the U.S. contributed about 8 grams of petroleum into the marine environment per day for each person living in the coastal zone. To estimate the oil input from these wastes in the KAP Region, we used the following reasoning: In 1979, the entire U.S. population of about 226 million consumed a total of 862.0 million tonnes of oil, or about 3.82 tonnes per person. The U.S. Census Bureau estimated that the population of the Middle East was about 83,714,000 in 1977. Oil consumption in the Middle East during 1977 was 78.9 million tonnes, or an average of 0.942 tonne per person, or 24.65 per cent of the 3.82 tonnes per capita U.S. consumption in 1979. If we assume that the discharge of municipal wastes and non-refinery industrial wastes is directly proportional to per capita consumption, and that the population in the coastal zone of the KAP Region has the same per capita oil consumption as the population in both the coastal and non-coastal zones of the Middle East, then about 1.97 grams of oil would be discharged per capita per day in the coastal zone of the Region.

According to RPI, the total population of the coastal and tributary areas in the KAP Region was about 6.2 million in 1976, and the U.S. Census Bureau statistics indicated that the population of the Region had increased at an average annual rate



of about 3.3 per cent from 47,861,000 in 1970 to 59,941,000 in 1977. If the coastal and tributary population of 6.2 million in 1976 also increased at this rate, it would have increased 10.1 per cent by 1979 to 6.83 million:

$$6.2 \text{ million} + (10.1 \text{ per cent} \times 6.2 \text{ million}) = 6.83 \text{ million}$$

Assuming an average per capita discharge from coastal municipal wastes and coastal non-refinery wastes of 1.97 grams per capita per day, the total oil pollution from coastal municipal wastes and non-refinery wastes in 1979 would be 4,911 tonnes:

$$\frac{1.97 \text{ grams}}{\text{person/day}} \times 365 \text{ days} \times \frac{6.83 \text{ million}}{\text{persons}} \times \frac{\text{tonnes}}{\text{million grams}} = 4,911 \text{ tonnes}$$

#### Urban Run-off

The NAS estimated that the oil pollution from urban run-off is approximately 50 per cent of the total world-wide input of oil from coastal municipal wastes and coastal non-refinery wastes into the marine environment. Assuming that this proportion holds for the KAP Region, urban run-off would account for approximately 2,456 tonnes of oil pollution in the Region during 1979:

$$50 \text{ per cent} \times 4,911 \text{ tonnes} = 2,456 \text{ tonnes}$$

#### River Run-off

The NAS calculated that, in the U.S. in 1970, the total amount of oil discharged into the marine environment through river run-off was 530,000 tonnes. In 1970, the U.S. consumed a total of 694.6 million tonnes (BP, 1980), and based on this amount, we calculated that the oil discharge rate from river run-off was 763.0 tonnes of oil discharged per million tonnes of oil consumed:

$$\frac{530,000 \text{ tonnes discharged}}{694.6 \text{ million tonnes consumed}} = \frac{763.0 \text{ tonnes discharged}}{\text{million tonnes consumed}}$$

Since the KAP Region has a primarily arid climate with few major rivers to carry oil pollution run-off, we have assumed that only the area's coastal and tributary population of about 6.83 million contribute a significant amount of oil pollution through river run-off into the Region. If we assume, as above, that the per capita oil consumption for the population in the coastal zone is 0.942 tonne per year, and that the discharge rate of oil into rivers is 763.0 tonnes discharged per million tonnes consumed, then the total discharge into the Region during 1979 was 4,909 tonnes:

$$\frac{0.942 \text{ tonne consumed}}{\text{person}} \times 6.83 \text{ million} \times \frac{763.0 \text{ tonnes discharged}}{\text{million tonnes consumed}} = 4,909 \text{ tonnes discharged}$$

### SUMMARY OF SPILL ESTIMATES

Table 2 summarizes the estimates that we derived in the earlier sections for each major source of oil pollution in the KAP Region. According to our estimates, approximately 144,000 tonnes of oil spilt into the marine environment of the KAP Region during 1979. This amount represents about 3.1 per cent of the NAS estimate

TABLE 2  
Total Estimate of Oil Pollution in the  
Kuwait Action Plan Region During 1979

<u>Source</u>	<u>Estimate in Tonnes</u>	<u>Percent of Total</u>
Natural Seeps	13,815	9.6
Offshore Production	32,162	22.4
Tanker Transport	82,032	57.1
Non-tanker Accidents	1,717	1.2
Coastal Refineries	1,347	0.9
Atmospheric Fall-out	396	0.3
Coastal Municipal Wastes & Coastal Non-refinery Wastes	4,911	3.4
Urban Run-off	2,456	1.7
River Run-off	4,909	3.4
<hr/> TOTAL	<hr/> 143,745	<hr/> 100.0

of 4,570,000 tonnes discussed earlier. A comparison of the NAS world-wide oil pollution statistics in table 1 with the KAP Region estimates in table 2 offers the following insights:

- 1) Whereas the oil pollution statistics for the world show that 15.4 per cent of the total comes from tanker transport and 4.4 per cent from offshore production, the estimates for the Region show that 57.1 per cent of the total comes from tanker transport and 22.4 per cent from offshore production. This high percentage of pollution from tanker transport and offshore operations in the Region is consistent with the high concentration of oil production and transportation activities in the Region.
- 2) The oil pollution statistics for the Region show that 3.4 per cent of the total comes from coastal municipal wastes and coastal non-refinery wastes and 1.7 per cent from urban run-off, whereas the estimates for the world show that 9.8 per cent of the total comes from coastal wastes and 6.6 per cent from urban run-off. This difference reflects the relatively low population density and low per capita oil consumption in the Region compared with the nations of Western Europe and North America.
- 3) Although the KAP Region comprises only 0.066 per cent of the surface area of the world's marine environment, our estimates indicate that it contributes 3.1 per cent of the world's marine oil pollution, which is 47 times the average estimated amount for a marine environment of similar surface area.

### TEN-YEAR PROJECTION OF OIL POLLUTION

On the basis of our estimates for 1979, we have estimated the volume of oil pollution in the KAP Region during the 10 years from 1980 to 1989. In deriving this volume, we have made the following assumptions:

- 1) The surface area and geologic setting of the KAP Region will remain constant so that oil pollution from natural seeps and from atmospheric fall-out will also remain constant;
- 2) Offshore production will increase at an annual rate of 1.7 per cent per year, as it did from 1978, with 4,727,000 barrels produced per day, to 1979, with 4,806,000 barrels produced per day. The associated oil pollution from offshore production will also increase at the annual rate of 1.7 per cent;
- 3) The volume of Middle East oil exports will increase at a 0.3 per cent annual rate, as it did during the five-year period from 1974 to 1979. The oil spill rates for tanker casualties, tanker cleaning and ballasting, and terminal operations will also increase at the rate of 0.3 per cent per year;
- 4) Middle East oil consumption will increase at a rate of 2.2 per cent per year, as it did between 1974 and 1979. The oil spill rates for non-tanker losses will also increase at the annual rate of 2.2 per cent;
- 5) The population in the KAP Region will increase at a 3.3 per cent annual rate, as it did between 1970 and 1977. The loss rates associated with urban run-off, river run-off, and coastal municipal wastes and coastal non-refinery wastes will also increase at the rate of 3.3 per cent per year;
- 6) The coastal refinery throughput will increase at the 7.8 per cent annual rate that refinery capacity increased during the five-year period between 1974 and 1979. The oil pollution associated with coastal refineries will increase at the same rate.

It is important to note that our calculations did not include any normalization factor for pollution that might result from natural disasters, sabotage, or war during the 10-year period. In addition, our projections did not assume any changes in the amount of oil production, consumption, and exportation in the Region as a result of natural disasters, sabotage, war, strikes, or embargos. Nor did we assume any changes as a result of improved technology, safety measures, and environmental protection legislation.

As an example of the types of unforeseen changes not accounted for in our projection, oil production in Iran dropped over 40 per cent from 260.4 million tonnes in 1978 to 155.6 million tonnes after the Revolution in 1979, and with the outbreak of war between Iran and Iraq this year, oil production figures for both countries are likely to show a substantial decrease during 1980. In addition, war-related oil pollution in Iran and Iraq will probably total many thousands of tonnes.

With these limitations in mind, we prepared table 3 for estimates of oil pollution in the KAP Region during the 10-year period from 1980 to 1989.

TABLE 3  
 Estimates of Oil Pollution in Tonnes for the Kuwait Action Plan Region.  
 Parentheses below contain annual growth rate for each category.

YEAR	Natural Seeps (0.0%)	Offshore Production (~1.7%)	Tanker and Terminals (~0.3%)	Non-tanker Accidents (~2.2%)	Coastal Refineries (~7.8%)	Atmospheric Fall-out (0.0%)	Municipal and Non-refinery Wastes (~3.3%)	Urban Run-off (~3.3%)	River Run-off (~3.3%)	TOTAL
1979	13,815	32,162	82,032	1,717	1,347	396	4,911	2,456	4,909	143,745
1980	13,815	32,700	82,311	1,755	1,452	396	5,071	2,536	5,069	145,105
1981	13,815	33,246	82,591	1,793	1,566	396	5,237	2,619	5,235	146,498
1982	13,815	33,802	82,873	1,833	1,688	396	5,408	2,705	5,406	147,926
1983	13,815	34,367	83,155	1,873	1,821	396	5,585	2,793	5,583	149,388
1984	13,815	34,941	83,438	1,914	1,963	396	5,767	2,884	5,765	150,883
1985	13,815	35,525	83,722	1,956	2,116	396	5,956	2,979	5,953	152,418
1986	13,815	36,119	84,007	1,999	2,282	396	6,151	3,076	6,148	153,993
1987	13,815	36,722	84,293	2,043	2,461	396	6,351	3,176	6,349	155,606
1988	13,815	37,336	84,580	2,088	2,653	396	6,559	3,280	6,556	157,263
1989	13,815	37,960	84,868	2,134	2,861	396	6,773	3,387	6,771	158,965
1980-1989	TOTAL 138,150	352,718	835,838	19,388	20,863	3,960	58,858	29,435	58,835	1,518,045

## HISTORICAL MAJOR OIL SPILLS IN THE REGION

Although we estimated that approximately 144,000 tonnes of oil pollution entered the KAP Region during 1979 and that more than 1,500,000 tonnes will enter the Region during the 1980s, we could not compare our estimates with hard data for the Region, due to the lack of a single comprehensive source of historical spill data for the Region. In an effort to fill this information gap, we compiled a list of major accidental spills that occurred in the Region during the period between 1966 and October 1980.

In developing the list, we conducted a literature search of periodicals and books on marine pollution and used data files from the following: the Oil Spill Intelligence Report, the Marine Pollution Bulletin, the Centre for Short-Lived Phenomena, the Canadian Environmental Protection Service, the U.S. Environmental Protection Agency, the Institut Français du Pétrole, the Bahrain Ministry of Health, and the University of Petroleum and Minerals in Dhahran, Saudi Arabia. We also developed data sheets requesting spill incident information and distributed these sheets to research centres, oil companies, and government agencies in the Region.

Our list contains data on about 30 individual spills and, as such, represents a first effort at compiling a data base for the Region. As an indication of the preliminary nature of our list, tankers reporting to the Japan Oceanographic Data Centre in Tokyo, Japan, sighted 139 slicks during 1978 and 273 slicks during 1979 in the Region and its approaches, while for the same two-year period, our table contained information on only 12 major incidents.

Although our list has limited usefulness given its preliminary nature, it nevertheless illustrates that single major spills may have a major impact on the total oil spillage per year in the Region. For example, the Lavan Island well blow-out in 1971 and the recent Hasbah 6 well blow-out in October 1980 each involved the spillage of an estimated 14,000 tonnes of oil into the Region, and that amount represents about one-third of our estimate for the total yearly spillage from all offshore operations. The 1972 tanker collision of the Sea Star and the Horta Barbosa resulted in the loss of more than 100,000 tonnes of crude oil into the Gulf of Oman. That amount was almost four times more than the 29,000 tonnes predicted for annual spillage from tanker casualties in the Region.

This discussion illustrates the need for hard data to test spill estimates and to determine the real magnitude of oil pollution in the Region. An incident-reporting network for the Region would allow researchers to confirm or revise their estimates, to pinpoint areas of greatest risks, and to develop effective spill contingency plans and pollution control legislation.

## RECENT MAJOR SPILLS IN THE REGION

Between August and December 1980, two major spills in the KAP Region received international attention. These spills have implications as case studies for researchers, policy makers, and response teams within the Region. They illustrate the need for techniques to monitor and track spills, schemes to compensate damage victims, contingency plans to ensure a rapid response, and scientific programmes to assess and monitor environmental impacts.

HISTORIC MAJOR OIL SPILLS IN THE KUWAIT ACTION PLAN REGION

DATE	SOURCE	LOCATION	TONNES SPILLED	TYPE OF OIL	CAUSE
20 Jun 66	British Crown British - 28,598 DWT	24°59'N, 51°37'E Umm Sa'id, Qatar	13,000	Qatar crude	explosion & fire
20 Apr 70	pipeline	(26°48'N, 49°54'E) Tārūt Bay, Saudi Arabia	14,000	Arabian crude	rupture
2 Dec 71	offshore platform	(26°50'N, 53°20'E) Lavan Island, Iran	14,000	crude	blow-out
1972	terminal	26°41'N, 50°11'E Ras Tannūrah, Saudi Arabia	70	Arabian light crude	loading mishap
2 Aug 72	Constantinos 16,210 DWT	25°16'N, 55°18'E near Dubai, United Arab Emirates	99	diesel & lubricating	equipment failure
2 Nov 72	Chryssi P. Goulandris 78,188 DWT	26°38'N, 50°10'E near Ras Tannūrah, Saudi Arabia	undetermined	undetermined	grounding
9 Dec 72	Sea Star South Korean - 120,300 DWT	24°53'N, 57°51'E Gulf of Oman	115,000	Arabian crude	collision
	Horta Barbosa 14,900 DWT	24°53'N, 57°51'E Gulf of Oman	66	fuel	collision
3 May 74	Isomeria 68,065 DWT	29°04'N, 48°09'E near MINā' al Ahmadi, Kuwait	(205)	crude	accidental discharge

DATE	SOURCE	LOCATION	TONNES SPILLED	TYPE OF OIL	CAUSE
3 May 74	Tosa Maru 72,658 DWT	29°02'N, 48°09'E near Mīnā' al Ahmadī, Kuwait	(205)	crude	accidental discharge
Jun 74	terminal	28°44'N, 48°28'E Mīnā Sa'ūd, Saudi Arabia	5,000	crude	undetermined
Jul 74	oil field	28°32'N, 48°59'E Khafji field	1,000	crude	undetermined
31 Oct 74	British Comet 36,908 DWT	30°26'N, 49°05'E near Bandar-e Shāhpūr, Iran	160	fuel	collision
31 Oct 78	pipeline National Iranian Oil Co.	30°20'N, 48°15'E Ābādān, Iran	undetermined	heavy crude	pipeline crack
2 Nov 78	Pobeda Oktyabrya U.S.S.R. - 16,279 DWT	(29°55'N, 48°26'E) Shatt al'Arab River	undetermined	undetermined	collision
30 Mar 79 to May 79	Pythia Greek - 17,365 DWT	(29°55'N, 48°26'E) Shatt al'Arab River	undetermined	undetermined	collision
8 Jul 79	Well No. 34 Arabian American Oil Co.	(27°22'N, 49°35'E) Abū'Alī Island	undetermined	crude	fire & gas release
8 Jul 79	pipeline National Iranian Oil Co.	30°34'N, 49°10'E Aghadir oil field Khuzestān, Iran	66	crude	● explosion & fire ● alleged sabotage

DATE	SOURCE	LOCATION	TONNES SPILLED	TYPE OF OIL	CAUSE
10 Jul 79	pipeline National Iranian Oil Co.	(30°20'N, 48°15'E) near Ābādān, Iran	undetermined	crude	<ul style="list-style-type: none"> <li>● explosion &amp; fire</li> <li>● sabotage</li> </ul>
15 Jul 79	submarine pipeline	26°41'N, 50°11'E Ras Tannūrah, Saudi Arabia	111	undetermined	puncture by ship anchor
24 Jul 79	Chastine Maersk Danish - 14,169 DWT	(29°20'N, 48°00'E) Kuwait, Kuwait	(150)	undetermined	collision
28 Jul 79	Al Soreya British - 1,016 DWT	24°28'N, 54°25'E Abū Dhabi, United Arab Emirates	undetermined	undetermined	fire
22 Aug 79	refinery Arabian American Oil Co.	26°41'N, 50°11'E Ras Tannūrah, Saudi Arabia	undetermined	undetermined	<ul style="list-style-type: none"> <li>● explosion</li> <li>● 2 dead &amp; 6 injured</li> </ul>
26 Aug 79	Patianna ore/bulk/oil carrier Liberian - 47,519 DWT	25°21'N, 55°10'E Dubai Roads	undetermined	crude	explosion & fire
27 Aug 79	Cherry Duke Singapore - 29,299 DWT	25°02'N, 53°10'E Dās Island	undetermined	undetermined	<ul style="list-style-type: none"> <li>● explosion</li> <li>● sinking</li> <li>● 5 missing</li> </ul>
3 Dec 79	Energy Determination Liberian - 321,186 DWT	26°36'N, 56°23'E Strait of Hormuz	undetermined	undetermined	<ul style="list-style-type: none"> <li>● explosion &amp; fire</li> <li>● sinking</li> </ul>



DATE	SOURCE	LOCATION	TONNES SPILLED	TYPE OF OIL	CAUSE
Aug 80	Gremona Spanish - 92,345 DWT	(26°12'N, 50°38'E) Bahrain	1,000	bunker oil	open valve
6 Aug 80	unknown	(26°06'N, 50°30'E) west coast of Bahrain	up to 2,750	undetermined	undetermined
3 Sep 80	oil storage tanks and refinery	30°20'N, 48°15'E Abādān, Iran	undetermined	undetermined	<ul style="list-style-type: none"> <li>● explosion &amp; fire</li> <li>● sabotage</li> </ul>
3 Sep 80 & following	oil facilities	30°30'N, 47°50'E Basra, Iraq	undetermined	various	explosion & fire
		29°27'N, 48°41'E Khor-al-Amaya, Iraq			
		29°55'N, 48°26'E Al Fāw, Iraq			
2 Oct 80	Hasbah 6 well Arabian American Oil Co.	(27°50'N, 49°40'E) Hasbah field, Saudi Arabia	up to 14,000	crude	<ul style="list-style-type: none"> <li>● blow-out</li> <li>● 19 dead</li> </ul>

Note: For spill information given as 'undetermined,' data was not available.

In late August, a 25-square-kilometre oil slick impacted the north and west coast of Bahrain. The oil was washed ashore along 65 kilometres of coastline, including several amenity beaches, and caused serious damage to fishing traps, nets, and tackle, as well as fishing boats. At the peak of the clean-up, a total of 800 workers were involved in the recovery of the spilled oil and the restoration of the beaches there. By early October, the crews had cleaned up the most severely affected regions, and the work force had been reduced in size to about 300 people. Several reports indicate that the oil spilt from a loading terminal in Saudi Arabia. If the terminal was indeed the spill source, rapid notification of pollution authorities might have resulted in the containment of the spilt oil near the terminal in Saudi Arabian waters and prevented its eventual movement onto the Bahrain coast.

In the second major incident, the Hasbah 6 well blew out about 100 kilometres off the Saudi Arabian coast and spilt between 5,000 and 10,000 barrels of heavy crude oil per day during the period from its initial blow-out on 2 October until its final capping on 10 October. The well, owned by the Arabian American Oil Co. (ARAMCO) of Dhahran, Saudi Arabia, spilt oil for approximately 200 hours and lost up to 80,000 barrels of oil. At its maximum, the Hasbah 6 slick covered at least 25,000 square kilometres, and on-scene observers said that the surface area of the slick was the second largest in history. During the initial blow-out, 19 rig workers were killed when hydrogen sulphide fumes were released along with oil and natural gas. The other crew members were evacuated safely from the jack-up drilling rig, owned and operated by Reading & Bates of Tulsa, Oklahoma.

The Hasbah 6 spill was a major transboundary pollution incident, involving clean-up crews in Saudi Arabia, Bahrain, Qatar, Iran, and the United Arab Emirates. North-westerly winds carried the oil from the Hasbah 6 well to the east and south into Iranian waters and towards Bahrain and Qatar. Initially, ARAMCO concentrated its clean-up efforts, involving both mechanical equipment and chemical techniques, on the leading edge of the slick to prevent the oil from washing ashore along the Bahrain coast.

As of 20 October, the slick was about 40 kilometres off Bahrain and about 20 kilometres off Qatar. Large amounts of oil had passed from Saudi Arabian waters into Iranian waters. During the last week of October, tar balls from the Hasbah 6 spill washed ashore along up to 100 kilometres of the northern Qatar coast, and the slick continued to move in a south-easterly direction towards the United Arab Emirates. As the slick moved away from the coast of Saudi Arabia and Bahrain, ARAMCO reduced its response level, although it remained ready to provide assistance and advice on request. Tar balls totaling about 100 barrels in volume also began to be washed ashore along 12 kilometres of the Bahrain coast, and clean-up crews used heavy equipment and manual techniques to remove the oil there.

The slick posed major problems for the islands between Qatar and the United Arab Emirates as a result of possible contamination of the water intakes for the power plants and desalination plants there. During early November, tar balls and sheen continued to be washed ashore along the coasts of Bahrain and Qatar and to threaten the coast of the United Arab Emirates. According to reports, the oil contaminated more than 300 kilometres of the Qatar coastline, including about 75 kilometres of amenity beaches. Iran also reported large amounts of oil in its territorial waters and along the shores of Lavan Island.

The Hasbah 6 incident focused attention on the need for multilateral and bilateral treaties to enable a nation in the KAP Region to respond quickly to a major pollution incident, whether an oil spill or a chemical contamination, that takes place outside its borders, but due to environmental conditions, such as winds

and water currents, eventually affects its own territories. From the first day of the blow-out, the Hasbah 6 spill had the potential for polluting the waters of the United Arab Emirates, more than 500 kilometres to the south-east. Ocean charts indicated that the wind and water currents would carry the oil eastwards and southwards towards the United Arab Emirates and that, as a result, the spill presented a real pollution threat to a large area of the KAP Region.

The Ixtoc 1 incident in the Bahia de Campeche, Mexico, provides another example of transboundary pollution. Following the Ixtoc 1 blow-out, the most effective response for the U.S. would have been to collect the freshly spilled oil at the well site, rather than to attempt to recover the weathered oil as it entered U.S. territorial waters. In fact, the efforts to recover the weathered oil were largely ineffective. At the time, the U.S. and Mexico had not finalized a bilateral contingency plan, and as a result, the legal mechanism did not exist to enable the U.S. to mount a clean-up effort at the well site.

The U.S. and Mexico had begun discussions on the bilateral contingency plan in 1977, completed a draft of the plan the following year, and finally signed the plan into effect in July 1980. The contingency plan contained the following objectives: 1) to develop a system for reporting spills that could have an impact on both Mexico and the U.S.; 2) to develop a joint programme for containing such spills; and 3) to provide the equipment, expertise, and other resources for cleaning up spills and minimizing their impact. According to the plan, the entire cost of the spill response would be covered by the country in which the spill occurs or, for outer continental shelf spills, by the country with jurisdiction over the activity responsible for the spill. The plan did not, however, provide a mechanism for resolving liability questions or damage compensation claims.

In addition to the problem of transboundary pollution, the Hasbah 6 incident focused attention on the need to understand the fate and behaviour of spilled oil in the Region in order to assess future environmental impacts and develop new response strategies. The dispersants that were sprayed on the slick had limited success initially, since the weathering of the spilt oil reduced the ability of the dispersants to penetrate the slick. In addition, the calm weather reduced the amount of natural mixing energy available to help disperse the oil. ARAMCO could not mount a major dispersant spraying operation in the Region due to the lack of aviation gasoline for use in DC-6 planes equipped with dispersant-spraying equipment. In the future, to fly extensive dispersant-spraying missions in the Region, authorities will need to stockpile aviation gasoline for the DC-6 planes or equip a turbine-powered aircraft with dispersant-spraying equipment.

The primary clean-up problems involved in the Hasbah 6 incident resulted from the characteristics of the slick. The tar balls had a neutral buoyancy, making them sometimes difficult to contain with booms. This characteristic increased the problem of protecting the water intakes at power plants and desalination plants along the affected coasts. In some areas, the oil had also become too viscous for an effective open-ocean recovery, and certain skimmers were unable to recover the oil.

When the Hasbah 6 blow-out took place, the affected countries requested assistance and equipment from sources as far away as Anchorage, Alaska, and London, U.K. ARAMCO considered the use of DC-6 planes from British Columbia, Canada, and contracted with Smit-Tak Anti-Pollution Services of Rotterdam, Netherlands, to airlift equipment and personnel to the spill area. Bahrain, the United Arab Emirates, and Qatar used equipment from British Petroleum Co., and Abu Dhabi retained the services of a clean-up contractor in Anchorage, Alaska, to provide support and advice. Given that the KAP Region is the largest oil producing and

exporting area in the world, incidents such as the Hasbah 6 blow-out provide an impetus for the countries within the Region to develop their own capability to deal with major spill incidents.

## COSTS OF OIL POLLUTION

For the purposes of this report, we have divided oil pollution expenditures into the following three categories: 1) costs associated with prevention, research, and clean-up of spills; 2) costs associated with the direct losses or damages resulting from a spill; and 3) costs indirectly associated with spills.

### Prevention, Research, and Clean-up Costs

Expenditures associated with spill prevention include the costs of developing and implementing spill contingency plans and training programmes, the costs of purchasing and maintaining safety and monitoring equipment, and the costs associated with employing safety and monitoring crews. The purchase and maintenance costs of pollution response equipment may be considered as either prevention or direct clean-up costs.

Research and development costs include the equipment and personnel costs that both government agencies and private organizations expend to develop containment, monitoring, and clean-up devices, and to study spill impacts.

Direct clean-up and treatment costs include expenses associated with deploying equipment as well as the salaries and other expenses incurred in the maintenance of administrative personnel, clean-up crews, and technical consultants. Clean-up costs also include the expenses associated with disposing of or reprocessing recovered oil, less the revenue for the recycled products.

### Direct Damage Costs

The direct costs resulting from a spill include: 1) the loss of catch or production from commercial fisheries or aquaculture operations damaged by a spill; 2) the loss of revenue from the petroleum products burnt, weathered, or otherwise lost in a spill; 3) the permanent or temporary losses of employment in fishing industries, retail and hotel businesses, and other industries affected by the spill; 4) the damage to private and public property, including fishing gear, ships, docks, beaches, and real estate; 5) the permanent and temporary reductions in rent receipts and sale prices of houses, hotels, and other real estate in areas affected by a spill; 6) the expense necessary to replace a water supply system or construct additional water treatment facilities; and 7) environmental resource damages.

### Indirect Costs

Indirect expenses associated with spills include: 1) the costs of spill liability insurance and product loss coverage for vessels, pipelines, offshore platforms, and shore facilities; 2) the communications costs and personnel expenses associated with documenting and reporting spills; 3) the fines and other penalties levied on spillers for violating regulations relating to pollution control, spill reporting, and clean-up procedures; 4) the legal costs, such as the filing of legal claims and the salaries for government and industry legal personnel; and 5) government and industry contributions to local, regional, national, and international spill funds.

## Historical Examples of Oil Spill Damages

The amount of damage and clean-up expense resulting from a major spill depends primarily on the spill location, size, type of oil, and time of year. Often, spill location is the most critical variable, as several spills totalling more than 100,000 tonnes have resulted in minimal damage claims and minimal long-term environmental impacts. A notable example of a large spill with minimal environmental impact was the collision of the 210,257-DWT Liberian tanker Aegean Captain and the 292,666-DWT Greek tanker Atlantic Empress on 19 July 1979, about 32 kilometres north of Tobago in the Caribbean Sea. In the explosion and fires that followed the collision, the two tankers lost a total of more than 140,000 tonnes of Arabian and Venezuelan crude oil. In spite of this massive spillage, and the proximity of the spill to Tobago, the environmental conditions combined to disperse the oil before it could reach any Caribbean island shore or major fishing ground.

In contrast to the collision between the Aegean Captain and the Atlantic Empress, many relatively small spills in particularly sensitive areas have resulted in extensive environmental damage and major clean-up expenditures. The spillage of only 0.01 tonne of oil from the vessel Okeanos near Brofjorden, Sweden, on 7 June 1977 required clean-up expenditure of 47,132 Swedish krona, and a spill of 105 tonnes from the 117,609-DWT Japanese tanker Ryu-yo-Maru in Yokkaichi, Japan, on 8 November 1978 required clean-up expenditures of 99.3 million yen and compensation to fishermen totaling 1,031 million yen.

The largest spill damages have accompanied a large spill in a sensitive environment. The grounding and eventual breakup of the 224,914-DWT Liberian tanker Amoco Cadiz off Portsall, France, resulted in the spillage of 223,000 tonnes, or 67 million gallons, of oil off the Brittany coast and caused extensive damage to the fishing grounds and amenity beaches there. One estimate placed the costs associated with the Amoco Cadiz incident at 270 million dollars, based on a cost of 4 dollars per gallon of oil spilled. This total cost may represent a conservative estimate since, during 1978 and 1979, many parties filed damage suits totalling over 3.1 billion dollars in U.S. courts. As of late 1980, France had spent 416 million francs on the clean-up operation alone and another 45 million francs in damage compensation to fishermen and oystermen. Since environmental damages have persisted in some locations along the Brittany coast almost three years after the spill, extensive losses to fisheries and the tourism industry may continue for many years.

The Ixtoc 1 may become the most expensive oil spill in history as well as the largest. At world prices in December 1980, the 140 million gallons of Ixtoc 1 oil would cost at least 100 million dollars. The damage suits pending in U.S. courts as of December 1980 totaled more than 365 million dollars. The loss of the drilling platform amounted to 21 million dollars, and the clean-up in U.S. waters had cost the U.S. Government more than 8.5 million dollars as of December 1980. Petroleos Mexicanos, the owner of the Ixtoc 1 well, said that it spent about 134 million dollars on the entire Ixtoc 1 spill response and that 25 per cent of its costs involved environmental protection measures, including dispersant spraying, oil recovery, and beach clean-up. Based on these estimates, the Ixtoc 1 may cost a total of more than 628 million dollars.

## CONCLUSION

We have identified the major sources of oil pollution in the KAP Region and have estimated the volume of oil that is likely to spill from each source in 1980.

We have also made a 10-year projection for the amount of oil that will enter the KAP Region during the next 10 years. We have found a major discrepancy between our projected estimates and the available spill data. This discrepancy will probably decrease with improvements in both the technology for monitoring oil spills and the legal system for enforcing spill reports, and also with improvements in the model for estimating oil pollution for the Region.

Our estimates demonstrate the need for assessing the magnitude of oil pollution around the KAP Region and for developing baseline studies to identify trends in oil pollution and to pinpoint areas and activities of high risk. An active spill incident reporting system would enable Governments to accumulate information on spill incidents, to identify activities that require regulations, to pinpoint areas of high spill frequency, and to develop compensation schemes for spill damages.

If our estimates portray accurately the magnitude of oil pollution in the Region in 1979 and during the next 10 years, then these estimates justify the development of training programmes within the Region for spill response personnel. These estimates also justify the formation of contingency plans to ensure adequate equipment and qualified personnel to deal with oil pollution emergencies, and the creation of a regional network of monitoring programmes to detect and monitor oil spills and to notify authorities about the location and movement of spills.

These estimates carry an important message for the Region, and we hope that authorities in the Region regard this paper not as an academic exercise in future forecasting but rather as a basis for action to reduce the amount of current and future oil pollution in the Region.

REFERENCES

- BARTHOLOMEW, J.C. and LEWIS, H.A.G. (1977) The Times Atlas of the World, London, Times Books.
- BERTRAND, A.R.V. (1979) Les principaux accidents de déversements pétroliers en mer et la banque de données de l'Institut Français du Pétrole sur les accidents de navires (1955-1979). Paris, France, Institut Français du Pétrole.
- BEYER, A.H. and PAINTER, L.J. (1977) Estimating the potential for future oil spills from tankers, offshore development, and onshore pipelines. In Proceedings of the 1977 Conference on Prevention and Control of Oil Spills, pp. 21-30. Washington, D.C., American Petroleum Institute.
- BRITISH PETROLEUM CO. (1980) BP Statistical Review of the World Oil Industry, 1979. London, British Petroleum Co.
- BRUMMAGE, K.G. (1973) What is marine pollution? In Symposium on Marine Pollution. London, Royal Institute of Naval Architects.
- CENTRE FOR SHORT-LIVED PHENOMENA (1970) Tarut Bay oil spill. Cambridge, Massachusetts, Centre for Short-Lived Phenomena.
- CENTRE FOR SHORT-LIVED PHENOMENA (1971) Lavan Island oil spill. Ibid.
- CENTRE FOR SHORT-LIVED PHENOMENA (1978) Major oil spills involving tankers: 1 January 1972 to 1 June 1978. Ibid.
- DEVANNEY, J.W. and STEWART, R.J. (1974) Analysis of oil spill statistics. Cambridge, Massachusetts, Massachusetts Institute of Technology.
- GOLOB, R.S., Executive Editor (1978-80) Oil Spill Intelligence Report. 1:Sample:2; 1:6:1,3; 2:12:17,18,20; 2:14:2; 2:19:2; 2:28:2; 2:29:2; 2:30:3; 2:33:3; 2:35:3; 2:38:3; 2:43:3; 2:49:3; 2:52:3; 3:1:1-36; 3:12:6; 3:15:1; 3:16:3; 3:18:2; 3:21:25,28,29,31,32; 3:22:2; 3:28:5; 3:29:4; 3:31:2; 3:36:2; 3:39:2; 3:40:2,3.
- JAPAN OCEANOGRAPHIC DATA CENTRE (1980) MAPMOPP Oil Slicks Data 1979. Tokyo, Japan Oceanographic Data Centre.
- NATIONAL RESEARCH COUNCIL - NATIONAL ACADEMY OF SCIENCES OCEAN AFFAIRS BOARD (1975) Petroleum in the marine environment. Washington, D.C., National Academy of Sciences.
- NEUMAN, L.D. (1979) The protection and development of the marine environment and coastal areas of the Kuwait Conference Region: The program of the United Nations system. In Proceedings of 1979 Oil Spill Conference, Los Angeles: pp. 287-91. Washington, D.C., American Petroleum Institute.
- OECD Environment Committee Transfrontier Group (1980) The cost to coastal States of accidental marine pollution due to oil spills. Paris, Organization for Economic Co-operation and Development.
- OOSTDAM, B.L. (1980) Oil Pollution in the Persian Gulf and Approaches, 1978. Mar. Pollut. Bull. 11:138-44.

- RESEARCH PLANNING INSTITUTE, INC. (1977) Oil Pollution in the Arabian Gulf - A preliminary survey. Columbia, South Carolina, Research Planning Institute.
- SPOONER, MOLLY (1970) Oil Spill in Tarut Bay, Saudi Arabia. Mar. Pollut. Bull. 1:166-7.
- SVERDUP, H.V., JOHNSON, M.W. and FLEMING, R.H. (1942) The Ocean. Englewood Cliffs, New Jersey, Prentice-Hall.
- UNITED NATIONS ENVIRONMENT PROGRAMME (1978) Final Act of the Kuwait Regional Conference of Plenipotentiaries on the Protection and Development of the Marine Environment and the Coastal Areas. Geneva, United Nations Environment Programme.
- U.S. CENSUS BUREAU (1978) World Population 1977. Washington, D.C., U.S. Government Printing Office.
- U.S. ENVIRONMENTAL PROTECTION AGENCY OFFICE OF RESEARCH (1973) International Scope of Marine Pollution Damage. Mar. Pollut. Bull. 4:149-52.
- WILSON, R.D., MONAGHAN, P.H., OSINIK, A., PRICE, L.C. and ROGERS, M.A. (1974) Natural marine seepage. Science (Wash.) 184:857-65.



EFFECTS OF OIL-INDUSTRY RELATED POLLUTION ON MARINE RESOURCES  
OF THE KUWAIT ACTION PLAN REGION

by  
A. Nelson-Smith

University College, Department of Zoology,  
Swansea, South Wales, U.K.

ABSTRACT

The physical environment, marine biota and fisheries of the inner part of the Kuwait Action Plan (KAP) Region are discussed, together with the location, operation and pollution record of oil-related industry there. The flora and fauna are restricted, but richer than previously reported. Some fisheries are declining, although others have not yet been fully developed. The inner sea area of the Region is subjected to stressful environmental extremes and also suffers from chronic oil pollution, waste discharges and mechanical disturbance by landfill, dredging, etc. The present and possible future effects of these are considered in comparison with the situation in arctic and temperate seas. Most biota appear to be holding their own but certain species and biotopes are at risk. Offshore operations and coastal development are incompatible with the efficient exploitation of some living marine resources.

## PHYSICAL ENVIRONMENT OF THE REGION

The Kuwait Action Plan (KAP) Region comprises the sea area between the Arabian Peninsula and Iran, the Gulf of Oman and a strip of the Arabian Sea bordering the south-east coast of Oman. This review concentrates on the inner of the two areas, which possesses a much more demanding natural environment and is also more at risk from pollution by oil and other substances hazardous to marine life.

This almost entirely enclosed sea is predominantly a very shallow one, with a bottom sloping gently from the low and indented coastline of Arabia on the western shore to an elongated basin attaining maximum depths of 80-100m close to the more linear and mountainous Iranian coast to the east (figure 1). Lying in an arid sub-tropical region, the sea area loses more water by evaporation than it receives in drainage from surrounding lands, so salinities are abnormally high: values reach 38.5 - 41 parts per thousand generally, may attain 70 parts per thousand at the head of inlets such as the Gulf of Salwah (between Saudi Arabia and Qatar) and easily exceed 100 in shallow lagoons. Lowered salinities are encountered only in the immediate vicinity of the few small rivers fed by precipitation in the Zagros Mountains and discharging across the Iranian coast, and up Shatt-al-Arab, the joint Tigris-Euphrates-Karun estuary which forms the very head of the sea area of the Region.

The main body of water is well mixed for most of the year although, at the mouth, there is a dense, high-salinity flow outwards along the bottom of the Strait of Hormuz which is balanced by a surface influx of Indian Ocean water passing along the east coast. This gives rise to a weak counter-clockwise circulation. The tides have a range of 0.5m in the mid-region, increasing to about 3m towards both the head and the mouth. Along much of the western coast, this is enough to uncover an expanse of sand and mud often several kilometres wide at low water; extensive sabkhas (salt-flats) may periodically become flooded at high water. However, tidal currents are strong only in coastal channels where bi-directional movements are concentrated. The wind is therefore an important factor: it blows predominantly from the north and most strongly from the north-west, as the shamal. All down the western coast in the inner part of the sea area, which trends NW-SE, the headlands demonstrate this with an extended sandspit which curves in the downwind direction. The fetch is thus greatest in the south-east, where bottom sediments are of coarse sand as a result of greater wave-energy: elsewhere, especially in deeper water, they are of fine sand or mud. Sediments of terrestrial origin are contributed either by streams along the eastern shore or by the wind; those brought down by the great rivers at the head of the Region are mostly trapped in the extensive marshes there, although a submarine delta has spread out across much of its upper end. The waters of the inner sea area are more turbid than in the Red Sea or Indian Ocean generally, with a euphotic zone about 20-30m deep - which nevertheless includes a large area of the bottom along the western side.

Air temperatures range seasonally from over 50°C to near zero and, because there are no great depths to buffer against such changes, the water reflects these fluctuations quite closely. Surface waters, especially near the coast, may reach 35°C in the summer and fall to 10°C during winter storms: the range in shallow lagoons or on tidal flats is, of course, even greater.

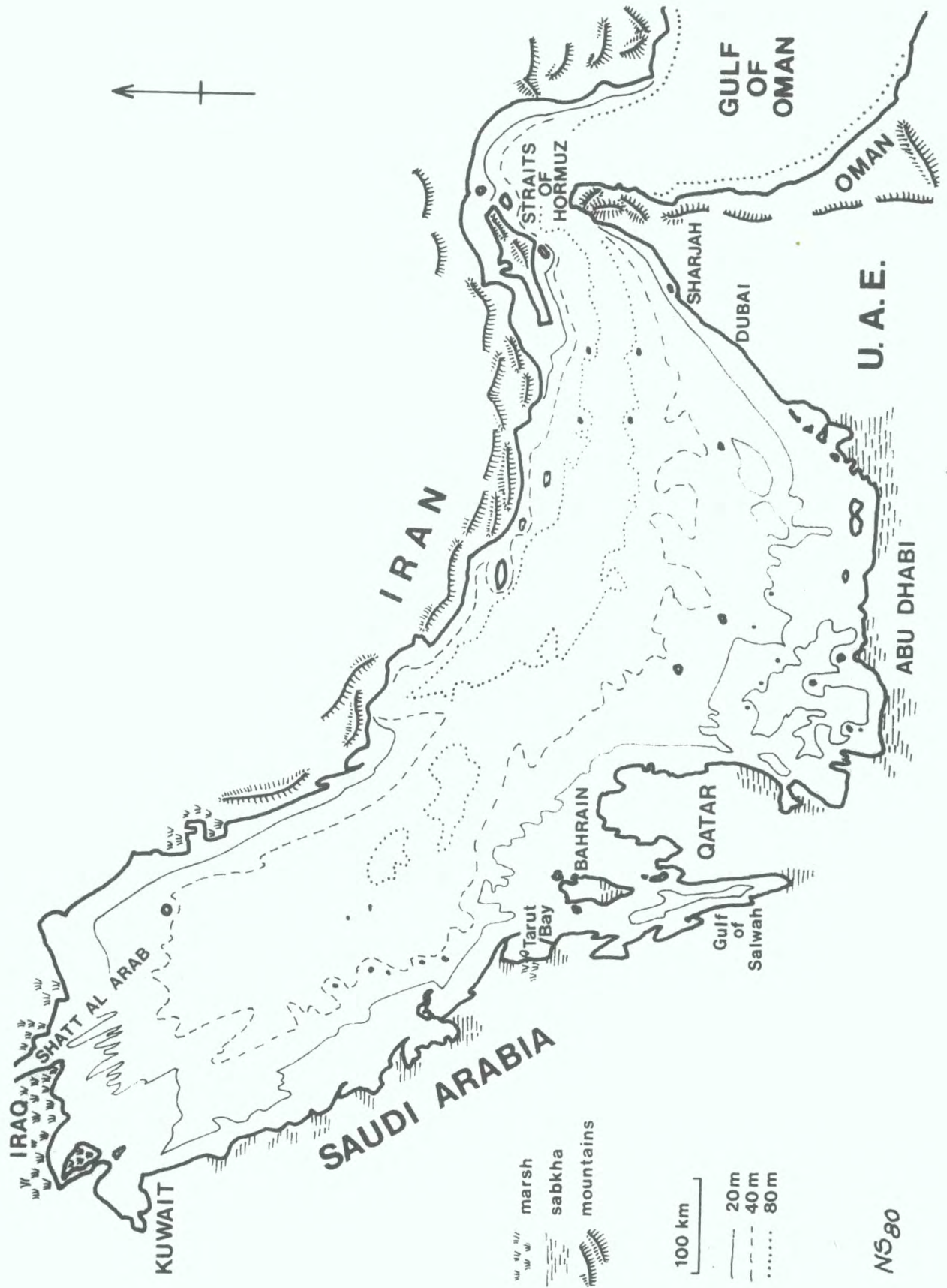

Figure I: The Kuwait Action Plan Region

NS80

## THE MARINE BIOTA

The high salinity, generally high but also fluctuating temperatures, other less important environmental conditions and the enclosed nature of the sea area all contribute towards restricting the variety of plants and animals which can survive there. Some early accounts give the impression that the diversity of many groups is very low, but further studies have shown that the marine biota of the Region is, in spite of these factors, quite rich. Mohammad (1971) was able to describe 79 species of polychaete worms, 29 of which were new records for the region and 3 species new to science, from Kuwait; Biggs (1973) listed from the Trucial Coast (United Arab Emirates) 198 species of mollusc, including many new records. To the 216 species of fish recorded by Blegvad and Loppethin (1944), Erdman (1950) was able to add another 30 during a few months spent around Dammam (Saudi Arabia), while a report by the State of Kuwait (Anon., 1974a) later concluded that the Region has about 350 species of fish. A recent publication (Basson, Burchard, Hardy and Price, 1977) which contains the essence of many years' work along the entire Saudi Arabian coast bordering the Region, and offshore, demonstrated that most habitats do indeed exhibit considerable diversity (table 1). From sublittoral soft bottoms alone they collected more than 167 different species of polychaete, 125 species of gastropod mollusc and 73 different bivalves, over 39 different amphipod crustaceans and 66 species of decapods (shrimps, crabs, etc.)

Table 1. Diversity of Species in Particular Habitats along the Western Coast of the Kuwait Action Plan Region

Rocky shores	131+
Intertidal rocks	314+
Sublittoral rocks	194+
Coral reefs	543+
Artificial structures	178+
Sandy beaches	218+
Intertidal sandflats	191+
Sublittoral sand	638+
Intertidal mudflats	109+
Sublittoral mud	610+
Seagrass beds	530+
Tidal creeks	33+
Plankton	355+
Open water	83+

From "Biotopes of the Western Arabian Gulf"  
Basson, Burchard, Hardy & Price (1977)

Because the surrounding land is very largely desert, nutrients can enter the system only via Shatt-al-Arab or, periodically, through the Strait of Hormuz; but intertidal micro-algae, sea-grass beds in the shallows and, to a smaller extent, mangroves and other halophytes around sheltered bays apparently make a contribution sufficient to permit relatively high productivity. The plankton has not yet been

exhaustively studied, but seems to be most diverse in the lower part of the Region, which receives a small contribution from the main Indian Ocean stock; in the shallower inner waters, certain components are missing but, in productive bays and lagoons, densities may be quite high. The zooplankton contains a high proportion of the larvae of benthic invertebrates. Amongst these, numerous species of crab and smaller crustaceans are important as adults in scavenging detritus and turning over surface sediments - a function also carried out by polychaete worms. Intertidal flats may support huge numbers of tiny gastropod snails, while rocks at low water can become heavily encrusted with bivalves and tubeworms.

Reef-building corals do not occur in the northern part of the Region, but form numerous reefs in the shallow waters to the south-west, towards the Strait and around the Gulf of Oman, together with broad fringes around the offshore islands. Again, recent workers have been able to expand the estimates of diversity previously reported: Kinsman (1964) compared records of 15 genera for the Region with a total of over 80 for the Indo-Pacific region as a whole, whereas Basson *et al.* (1977) listed 43 species of scleractinians (stony corals) in 28 genera, together with 2 species of soft coral, from reefs off the Saudi coast alone. This might be compared with the 30 or so species recorded for the northern end of the Red Sea which, although at the extreme edge of their geographical range, offers more stable environmental conditions.

Mention has already been made of the contribution of blue-green algae to the productivity of the Region: extensive mats of these micro-organisms, occurring on sheltered intertidal flats, have much the same importance as salt-marsh vegetation in temperate seas. Mangroves, which offer a valuable coastal habitat in tropical regions elsewhere, are poorly developed in the area and occur only patchily along the southern and western shoreline - perhaps partly because of intensive human use in the past. The densest stands occur along each side of the Strait of Hormuz. Smaller halophytes are widespread in bays and creeks, covering the intertidal flats above the level of algae or mangroves and merging with reedbeds in the few localities (as around Tarut Bay, Saudi Arabia) where there is a freshwater seepage. Just below tidemarks, sea-grass beds are probably a source of nutrients even more important than the blue-green algae; they stabilize large areas of soft sediments and also provide support or shelter to many species ranging from protozoans to reptiles.

The KAP Region contains a variety of rare or threatened vertebrates as well as these more commonplace plants and animals. Green turtles are amongst the best-known of these, feeding on sea-grass beds and breeding on certain of the offshore islands; four others (the hawksbill, leatherback, loggerhead, and Ridley's turtle) are also known to use the Region. Sea-snakes - perhaps fortunately - seem to be less frequently seen, although at least six species are recorded. Dugongs have been reported but are thought to be very rare now, maybe because of the scarcity of dense mangroves which were their favoured habitat. Several species of porpoise, dolphin and killer-whale occur in the region, and a number of the larger whales regularly visit it. The wide variety of birds reported from the Region includes both typically marine species such as cormorants, sea-duck, gulls or terns and those associated more with the water's edge, like the herons, egrets, waders and kingfishers. Ospreys and kites also feed along the coast. The offshore islands are important breeding sites for three species of tern as well as for the turtles, and provide a resting-place for many other birds on the spring or autumn migrations across the Region.

## FISHERIES

Traditional methods utilizing nets and lines from the shore or small boats have, of course, been followed for centuries. In shallow water - as in Tarut Bay - fixed traps or fish-weirs may also be used. About 135 species of fish found in the Region are regarded as edible (Anon., 1974a). Their commercial exploitation began in the late 1950s or early 1960s, during which period landings doubled to about 40,000 tonnes, the major portion being divided between Iran and Iraq; a proportion of the fish landed were probably caught outside the Region itself. The fishery for pelagic species (sardines, mackerel, tuna and barracuda) lies mainly in the south-east and is exploited by Iran to supply a cannery at Bandar Abbas; trawling for demersal (bottom-living) species such as bream, jack, snapper, grouper or various flatfish can be carried out wherever the sea-bed is flat and fairly shallow. Estimates of potential yield range from 200,000 to 600,000 tonnes per year (various sources quoted by Crisp, 1976) - i.e. from around five to ten times the present catch.

There is also a commercial trawl fishery for penaeid shrimps, described in detail for Saudi waters by Price and Jones (1975) and Price (1979), which began during the same period. Data are hard to analyse, as there are several stocks, each exploited by more than one fishing fleet. In the early 1960s, landings amounted to about 2,000 tonnes per year which, as the fishing effort was increased, rose to a peak of some 16,000 tonnes during 1967-68, taken by about 125 vessels; by 1970, a larger fleet of 200 or so trawlers could manage only a slightly smaller joint catch of 15,000 tonnes. This was not commercially feasible since, as Enomoto (1971) pointed out, one trawler needs an annual catch of at least 100 tonnes to be profitable. As the catch continued to decline, boats were laid up. During the early to mid-1970s, total annual landings fluctuated around 10,000 tonnes and, more recently, are reported as being disappointingly low. The major stocks appear to be one or more in the north, fished by Iran, Kuwait and Saudi Arabia; a southern one, fished by Saudi Arabia, Bahrain and Qatar; and a further fishery around the Strait of Hormuz, exploiting a different species of shrimp. Price (1979) estimated the maximum sustainable yield of the two in which Saudi Arabia participates as around 2,500 tonnes each per year, rationally managed. Kuwait drafted regulations for commercial trawling in such a way that her artisanal fishery was protected and, further south, it appears that local fisheries have not declined as dramatically as the industrial ones.

Price and Jones (1975) listed eight species of "prime" fish and 36 species of "trash" fish taken by a commercial shrimp-trawler during the 1974-75 season. Even though the nets are operated so as to take as few as possible, fin-fish often amount to one-third of the catch and sometimes exceed the weight of shrimps, so that a trawler may take as much as 500 tonnes of fish per year, most of which are dumped back into the water. It would thus seem more efficient to operate these trawlers for a combined shrimp and fin-fishery, especially if a fish-meal industry could be established to utilize the species unsuitable for human food. Various investigators have suggested means of improving the shrimp fishery itself, ranging from protection of the natural breeding-grounds, through the early release of artificially-reared young to boost "wild" stocks, to a Japanese-style culture of mature shrimp in tanks. Artificial culture could also be used to form the basis of new or renewed exploitation of turtles and bivalves. At present, very few turtles are taken in the Region, although it may be the only breeding area for those caught off the coast of Pakistan. Greater damage may be done by the haphazard searching for eggs described by Basson *et al.* (1977). Turtle farming, as carried out (for example) in the Caribbean, involves collecting eggs and rearing the turtles to commercial size in captivity, with the option of releasing a proportion of young turtles in order to

maintain wild stocks. There used to be a flourishing fishery for pearl-oysters, mainly from Kuwait and the Emirates, in the southern part of the Region; this declined with the advent of cultured pearls, but conditions would still seem to be suitable for the farming of oysters and other bivalves for food.

### THE OIL INDUSTRY

The activity for which the KAP Region is best known throughout the modern world is the production and export of petroleum. The extraction of oil in commercial quantities began over sixty years ago; production has grown at an increasing pace during more recent years (table 2) and the search for new fields continues today. Although the smaller, more heavily exploited stocks may last for less than another twenty years, some fields seem good for almost a further century if carefully managed.

	1950	1960	1970	1975	1979/80
Inner Region					
Iraq (1927)*	0.1	0.9	1.5	2.2	3.5
Kuwait (1946)	0.4	1.7	2.9	2.2	2.5
Saudi Arabia (1938)	0.5	1.3	3.8	6.8	9.5
Bahrain (1934)	.03	.05	-	.06	.05
Iran (1913)**	0.7	1.1	3.8	5.4	3.1
Outer Region					
Qatar (1949)	.03	.17	.36	.44	.51
Abu Dhabi (1962)	0	0	-	1.4	1.5
Dubai (1969)	0	0	-	.25	.35
Gulf of Oman					
Sharjah (1974)	0	0	0	.38	.12
Oman (1967)	0	0	-	.34	.29

\* Some by pipeline to Mediterranean ports.  
 \*\* Recently some to outer Region.

The vast majority of this oil is carried from loading terminals throughout the length of the Region, predominantly along its western and southern coasts, through the Strait of Hormuz (figure II). A variable but potentially large proportion of Iraq's production can be piped to the eastern Mediterranean, while a line now being constructed across Saudi Arabia will, in a year or two, carry a smaller proportion of her output to Yanbu on the Red Sea. About 5 per cent of Saudi production was piped to the Mediterranean when TAPline was still in use. Familiar overall statistics are that about one-third of the world's oil is produced around the sea area of the Region, which carries nearly two-thirds of all oil exports: between 20 and 100 tankers may pass through the Strait in this trade during a single day to a wide range of destinations (table 3). In addition to the usual scattered sources of more detailed statistics, useful data on port facilities and shipping movements have been summarized in two economic studies (Anon., 1977, 1979) and a recent handbook (Gimson, 1980).

1979 figures

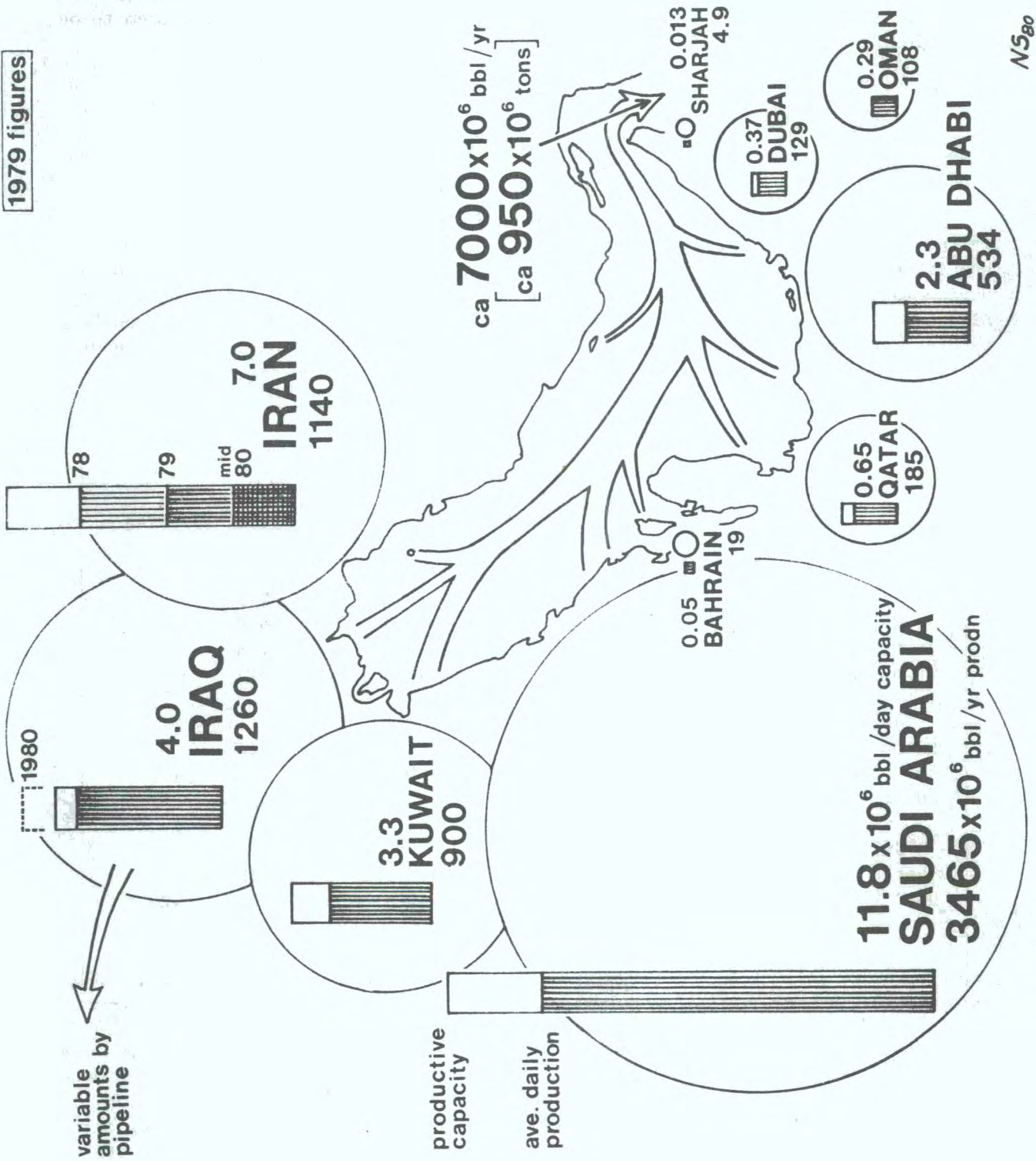

N580

Figure II: Carriage of oil through the Region



Table 3. Destination of Seaborne Middle East Crude Oil and Products, 1977 (mn tonnes)

Westbound (mostly by the Cape of Good Hope)		
Western Europe (northern)	257	
North America (eastern)	111	
Caribbean	47	
South America (eastern)	37	
Africa (south and east)	27	
Africa (west)	6	
Sub-total		485
(mostly by the Red Sea and Suez)		
Western Europe (southern)	189	
USSR, Eastern Europe	15	
Africa (north)	1	
Sub-total		205
Westbound Sub-total		690
Eastbound		
Indian Sub-continent	16	
South-East Asia	84	
Australasia	12	
Japan	196	
North America (western)	26	
South America (western)	2	
Sub-total		336
Total		1026

From: H. P. Drewry  
(Anon., 1979)

Many of the oilfields lie well offshore, together with most of the terminals at which the larger tankers load, while most of the recent or planned oil-related industrial developments are located along the coastline. It has been estimated that investment may reach 40 million US dollars per kilometre along the southern and western shores (Anon., 1976; Neuman, 1979) while a figure of 20 million was, at that time, projected for the Iranian coast. Trends in such investment suggest a slow but steady growth in production, refining capacity and export, a slightly greater increase in oil-based fertilizer manufacture and a considerable increase in petrochemical production (McLachlan and Ghorban, 1979). Thus every activity, from exploratory drilling to by-product manufacture, may have a growing effect on the marine environment.

#### OIL POLLUTION

Information on oil spillage in this area, published up to the time of writing, is sparse and clearly gives only a very patchy view of the full situation. During the past fifteen years, the major reported incident was the loss of nearly 150,000 tonnes from a tanker in the Gulf of Oman; within the inner part of the Region, four

spillages have been made public, each amounting to several thousand tonnes and arising from incidents involving a tankship, an onshore pipeline, an offshore well and a loading terminal. Two more of around 50-500 tonnes also occurred at loading terminals. Two serious incidents within the past few months have not yet been fully reported, nor has the incidence of pollution resulting from damage caused by recent hostilities in the north of the Region. Unpublished reports from tanker operators and insurers include 25 further spillages of over 100 barrels (sometimes very considerably more) during the last eight years. Reports of smaller spillages average about 100 per year but have been declining recently, from 138 in 1974 to 50 in 1979. A quarter of these occurred in the north of the Region, 70 per cent down the west coast and the remaining 5 per cent along the outer part, from Qatar to Oman. Oostdam and Anderlini (1978; quoted by Oostdam, 1980) gave data for Kuwait alone, showing 109 spills during the period 1965-76 totalling 220 tonnes (which is less than 0.0002 per cent of the amount of crude shipped) and averaging one per 24 ship movements. Beyer and Painter (1977) estimated that, world-wide, one nearshore tanker spillage might be expected per 1,000 vessel port-calls, but their calculations appear to exclude small incidents (the average spill was of nearly 1000 tonnes). They found that the total volume spilt by tank-shipping was 0.0087 per cent of the amount carried; in offshore operation, the proportion was 0.0072 per cent of production. Taking  $1,000 \times 10^6$  tonnes as an approximate estimate of the amount of crude oil shipped annually through the Strait of Hormuz (see table 3 and figure II), the first of these percentages suggests an average annual total spillage of nearly 9,000 tonnes from tanker operation alone. It is less easy to estimate spillage from offshore and onshore fixed structures.

Oostdam (1980) made calculations on the basis of reports from shipping to the Japanese Oceanographic Data Centre during 1978. More slicks were seen in the Gulf of Oman and Strait of Hormuz than in the inner part of the Region. He estimated that the standing stock of spilt oil is about 160 million tonnes and, at a residence time of one year, that this figure must also represent the annual input. This suggests that the Kuwait Action Plan Region receives 15-20 per cent of the world total of marine oil spillage.

#### IMPACT ON MARINE RESOURCES

Despite the somewhat unexpected richness of marine life in the Region, it is a very demanding environment to which many of its inhabitants have to make special adaptations. For example, over most of their range, reef-building corals flourish best in temperatures of 25-29°C and salinities of 34-36 parts per thousand, normally requiring these parameters to remain fairly stable; conditions in the southern part of the Region are so far from optimal that Kinsman found it worth while to publish a paper (1964) placing on record the tolerance by local corals of limits beyond the previously recognized maxima. Jones, Price and Hughes (1978) found that no macroscopical plants and few species of animals could survive in lagoons along the southern Saudi coast, although fish of edible size were caught there and conditions seemed suitable for rearing shrimp larvae. In this, as in other special environments, the biota make up for low diversity by a great abundance of the few tolerant species; but there is always the danger that such an ecosystem may be unable to adapt to changed circumstances. The results of human interference, superimposed upon demanding natural conditions, may lead to serious disturbances of the equilibrium which a less stressed system could more readily absorb.

Of course, it is rarely easy to isolate the causes of undesirably extreme or rapid changes in a complex system. The decline of the shrimp fishery, for example,

has apparently been brought about by a combination of such factors as overfishing, perhaps locally to the extent that an inadequate breeding-stock remains; a reduction in the influx of nutrients following recent restrictions on freshwater flow down the great rivers; excessive algal growth and lowered oxygen levels in enclosed bays; an increase in pollution levels in some of these inlets; and the growing practice of infilling such bays, creeks and lagoons with rubbish and spoil to extend coastal areas under industrial development. With all of these factors to consider, it is difficult to estimate the specific influence of present or future oil pollution. The susceptibility of different groups of plants or animals - sometimes even of closely related species - to a given adverse influence is as widely varied as their importance in a particular ecosystem, so that the consequences of any specified activity which might affect the marine environment cannot readily be characterized simply as acceptable or unacceptable. The biotope handbook, frequently referred to in this review (Basson *et al.*, 1977), is one by-product of a major effort by the Arabian American Oil Company (ARAMCO) to characterize the number, extent and importance of definable marine habitats or communities in the western part of the Region so that the impact of their continuing or extended operations and possible new developments can be assessed in terms of its overall importance to the ecology of the region; used widely, such a concept is much to be applauded.

The biological effects of reported spills have been considered in detail in only one case, a pipeline rupture at the northern end of Tarut Bay (Spooner, 1970a,b). Mortalities amongst the plants and animals of the shore were low enough to permit fairly rapid recovery, and, although local fisheries were temporarily disrupted, the approximate synchrony of this spillage with the decline in shrimp landings is clearly coincidental. However, relatively infrequent heavy spillages constitute only one of the possible impacts of the oil industry. Offshore exploration may result in disturbance, for example of turtles and seabirds attempting to breed on the islands, or marine mammals following migration routes between the reefs; drilling certainly produces a plume of sediment, occasionally contaminated with toxic constituents of "mud". Corals are particularly intolerant of such an increase in turbidity which is, to a lesser extent, unfavourable to most sedentary benthic organisms. Effluents from production or separation plant may be hot, containing either suspended oil or harmful substances in solution. Refineries and petrochemical plants discharge larger volumes of effluent into coastal waters, inevitably containing oil in quantities which are quite large when one considers what is contributed to the local environment over a period of time. Spooner (1970a) noted that the balance between algae and grazing invertebrates on intertidal flats near a refinery effluent channel had become tilted in favour of the algae, presumably over a long period, in the same way as had occurred elsewhere as a result of the oil-spill which she was investigating. The effluent was (and continued to be - see Wennink and Nelson-Smith, 1977) noticeably oily. The operation of tank-ships and loading terminals gives rise to many small discharges of oil, oily water or tank-sludge which may often be unavoidable, in practical terms. The oily component may travel as a surface slick, become incorporated with sediment particles or detritus in midwater or rapidly sink to the bottom but - unless it is degraded by physicochemical or biological agencies first - it will eventually end up as a tarball on a beach, perhaps many miles from the nearest shipping-lane or oil installation. Such deposits have now been reported from sea-coasts all around the world and are abundant in the Region, sometimes forming areas resembling a tarred foot-path along short stretches of the upper shore and encrusting up to one-half of the periphery of certain offshore islands.

The biological damage caused by polluting oil depends not only on the size and duration of the spillage but also on the nature of the oil and the type of organisms most exposed to it. Numerous books and papers provide more detailed information (see e.g. Nelson-Smith, 1972-3, 1975; Cowell, 1976; Wolfe, 1977; Anon., 1980a). In

brief, fresh crude or light products tend to penetrate well and have toxic, internal effects; weathered crude or heavy products tend to smother and have mechanical, external effects. The smallest marine organisms often become physically trapped in streaks or globules of oil, although larger mobile animals may be able to escape completely into clean water. Even sedentary forms which cannot avoid contact with it are not readily "wetted" by moderate quantities of oil, because of their slimy mucous or mucilaginous coating. They are more often damaged by the ingestion of contaminated food, by toxic components leaching into the water or by indirect effects upon gas exchange, thermal absorption or light penetration in shallow still waters. Essentially terrestrial organisms such as birds, fur-bearing marine mammals and maritime higher plants unfortunately have an outer covering which, although water-repellent, is readily "wetted" by oil and may be structurally disrupted by its penetration. They may therefore be seriously affected by contact with quite small quantities: an oiled leaf invariably dies and many birds have perished, at least in colder seas, as the result of only moderately-sized splashes in vulnerable areas of their plumage.

The operations which could readily give rise to pollution mostly take place in the north or down the western and southern shores of the sea area of the Region (with the exception of tanker accidents at sea, which are possible anywhere but most likely when approaching the Strait of Hormuz); water movements then tend to concentrate drifting oil into the sheltered inlets in the south-west, particularly along the Saudi coastline, in the Gulf of Salwah and towards the eastern end of the coast of Abu Dhabi. It seems probable that pollution would therefore clear rapidly from waters off the eastern Iranian coastline and this tendency, together with their greater depth, should help to protect the pelagic fishery whose greatest potential lies there, together with at least a proportion of the Region's turtles and other threatened species inhabiting island nature reserves along that coast. In the extensive shallows on the opposite side of the sea area, where most oil would gather, chemical and microbiological degradation should at least proceed swiftly, shortening the duration of an impact which might otherwise be much more severe. There is some evidence that a moderate level of pollution might even benefit the blue-green algae which make an important contribution to primary productivity locally; but its influence on macroscopic life cannot be other than unfavourable. The fisheries both for shrimp and demersal fin-fish are likely to suffer from a widespread spill not only in direct effects on adult animals, together with the fouling of gear (especially fixed traps and weirs) but also from damage to stocks of their larvae and food organisms. The possibility of developing a fishery there for bivalves might well suffer from the fact that these filter-feeders pass large volumes of water through their bodies, extracting suspended matter including oil-droplets as potential food. They are thus very liable to acquire an unpleasant taste in chronically polluted areas or after an oil-spill. Such tainting can occur at concentrations well below those which seriously endanger the health of the molluscs and some months in clean water may be needed before it is completely discharged; the problem can also affect other fisheries. "Off" tastes are more easily detectable in frozen, canned or fresh products than in those preserved traditionally by salting or drying; customers are less prepared to accept them in high-quality products and the more health-conscious ones tend to associate hydrocarbon contamination with cancer-risk. Corals, sea-grass beds, intertidal invertebrates, marsh vegetation and mangroves - each making a significant and specific contribution to fisheries and the stability of the environment as well as being of value in their own right - are all most at risk in this part of the Region.

It might be noted, in passing, that not all activities of the oil industry are actually or potentially unfavourable to other marine resources. As in other shallow seas where the bottom is mostly soft, the solid structures built for offshore operations rapidly become colonized by algae and sedentary animals, which, in turn,

attract small fish and their predators. This is ecologically beneficial, although its influence on the success of commercial fisheries may be small. More generally, the activities of trawl fishermen and offshore oil operators are incompatible; one serious constraint on the development of a more wide-ranging demersal fishery is the damage which most types of trawling gear could inflict on sub-sea pipelines (Anon., 1980b) and which itself might become a significant potential cause of pollution. Indeed, indiscriminate trawling can also damage other natural resources of the sea-bottom, such as sea-grass beds (see Basson *et al.*, 1977).

#### PREFERRED CLEAN-UP METHODS

Much will be said during this Workshop about the technical and logistic aspects of oil-spill clean-up, which have already been discussed, for the Saudi coast, by Wennink and Nelson-Smith (1977); here, a few comments on ecological aspects may be helpful.

It is fairly obvious that biologists, like all others involved, would prefer rapid containment and mechanical recovery to the uncontrolled spread of a slick and the necessity to add further chemicals in the form of dispersants, however innocuous. Unfortunately, this is rarely attainable in practice. Bearing in mind the unusually large proportion of shallow water in the Region, we would only ask that dispersants are used as far from shore, and in as deep water, as possible. Even now, little is known about the impact of dispersants and chemically-dispersed oil on tropical ecosystems (see Nelson-Smith, 1980a) but a coral reef would certainly appear to be especially susceptible to damage by fine suspended droplets of oil in high concentrations; many of the lagoons and bays are poorly flushed; and beaches are predominantly of soft sediments or porous rock over which the use of most dispersants only serves to facilitate the penetration of oil. Whilst many mechanical methods of recovery still leave much to be desired, in some sheltered shallow inlets with reasonable access from land this would appear to offer the best possible chance of success. When using such methods, it should be remembered that some constituents of crude oil have a relatively high solubility in water at typical temperatures in the Region and that this may become the most toxic fraction. Not only should spilt oil spreading over shallow water in sensitive areas be dealt with as rapidly as possible, but care should also be taken in discharging mechanically separated water which, through prolonged contact, may have acquired much of the toxicity of the recovered oil.

Amongst the few widely published accounts of oil-spills in the KAP Region, the only one to mention clean-up methods was again that by Spooner (1970a,b). Much oil was trapped by causeways and jetties; as access is good, it was possible to remove this mechanically by skimmers and suction hoses. Dispersant was used on slicks to prevent their escape from the bay, but not in very shallow water where it was thought that the necessary agitation would only have mixed oil droplets into bottom deposits. She commented that oil which covered and partly soaked into intertidal rocks was rapidly removed by grazing gastropods, as on rocky shores elsewhere both in the tropics and temperate zones. Excessive application of dispersant would also have interfered with this form of natural clean-up.

The waters around islands supporting important bird colonies constitute an area where priority should be given to any reasonable treatment which will remove oil from the surface; conversely, stands of mangroves and other halophytes or coastal marshes are regions where doing nothing is preferable to any treatment at present known. The effect of dispersants or dispersed oil on sea-grass beds has not yet

been recorded for publication; such an investigation would provide a valuable basis for decisions on how to deal with slicks entering the many inlets whose bottom is dominated by that biotope. As with all human activities, there is a need for compromise between the ideally desirable and the practically attainable; such a compromise is best achieved by knowledge of at least the main factors involved, and prior agreement between all interested parties as to what must be done and who plays which part in it. A good basis for the first requirement is a scheme similar to ARAMCO's categorization of coastal biotopes, referred to above. Such studies at least make it possible, when deciding on action which could do ecological damage, to concentrate that risk into an area where such damage would matter least, or where recovery should be most rapid. The second requirement is met, at least at a technical level, by the detailed working of such organizations as GAOCMAO (the Gulf Area Oil Companies Mutual Aid Organisation) and now the Kuwait Action Plan: it is important to stress the need to incorporate ecological advice in the earliest stages of such planning.

#### COMPARISON WITH ARCTIC AND TEMPERATE WATERS

Some important fundamental points come to light as a result of making comparisons between sea areas in which widely differing conditions prevail (see e.g. Johannes and Betzer, 1975). A non-gaseous, slightly soluble substance such as crude oil reaches higher concentrations in tropical than in colder waters. Since their metabolic rates will also be higher, warm-water organisms should experience a greater uptake of such pollutants which, at a given concentration, ought anyway to be more toxic. On the other hand, spilt oil loses its more volatile components (which include those which are both more toxic and more readily available to marine biota) to a greater extent and at a faster rate at higher temperatures, whilst the physico-chemical and microbiological degradation of what remains proceeds more rapidly. Once within an organism, those substances which can be detoxicated or excreted will also become harmless that much quicker. What might nullify the obvious conclusion that these effects tend to compensate for each other is the fact that, in shallow tropical or subtropical waters, not only do the biota have a small range of tolerance of environmental variables; they are also often living very near to their upper limit even under normal conditions. Being therefore already physiologically stressed, they may not have a margin even for limited additional burdens. In the shallower parts of the sea area (where spilt oil is most likely to collect), occasional spells of abnormally low temperature must add considerably to natural stresses. Apart from this, seasonal changes are minor and, although most of the plants and animals go through an annual cycle, there is no readily identifiable period when a pollution incident would generally be markedly more or less serious.

The Arctic experiences conditions which, in many ways, appear to reach extremes in the opposite direction to those in the Region. Temperatures (and sometimes salinities too) are low, while most biota show great seasonal fluctuations mainly controlled by a very short period of high phytoplankton productivity in the late spring or early summer. The temperature of the water itself does not fall below freezing-point (about  $-2^{\circ}\text{C}$ ) and, in any case, low temperatures are seldom as stressful, for animals which are adapted to them, as high ones: typical arctic sea-temperatures are usually many degrees below the upper tolerance limit. It might appear, at first sight, that a substantial oil-spill around the time of the plankton peak would be much more serious than during any other period, but the situation is complicated by the presence of ice, its movements and its cycle of melting and freezing. Under many circumstances, oil spilt at other times of year could be

trapped beneath seasonal ice-cover and then released during that period virtually unchanged. Some methods cannot work and others require the development of special materials or equipment. The subject has recently been reviewed by this author (Nelson-Smith, 1980b).

Temperate waters such as those around north-western Europe enjoy, to a certain extent, the best features of both global extremes. Most habitats support a mixture of cold-water and warm-water forms, favoured by conditions at opposite ends of the seasonal range so that, although a period can be defined during which a large spillage would be most damaging, a certain number of organisms are at their most tolerant at almost any time of year. Many are fairly cosmopolitan in their distribution, offering a greater potential for recovery or recolonization than exists in regions (like the Arctic and enclosed tropical waters) where endemic species make up a relatively high proportion of the total. Normally, temperatures do not approach the limits of tolerance, although other environmental variables may stress certain sensitive species. In favourable conditions, spilt oil is degraded fairly rapidly; a wide range of clean-up methods is available, although many are not necessarily very effective and some can be ecologically damaging.

Superficially, it would appear that the marine biota of the Kuwait Action Plan Region are surviving quite well a high incidence of low-level oil pollution and the effects of numerous, if ill-reported, larger spillages. However, we are still ignorant about many aspects of tropical and subtropical marine ecology, particularly the effects of human interference: such a conclusion may merely be a result of this ignorance. It is especially worth noting that most available methods for containing, collecting, dispersing or deflecting spilt oil were developed in the temperate zone. Toxicity testing leading to recommendations for world-wide use is normally carried out in laboratories there, using the common species of that zone under typical conditions of temperature, salinity, etc., and most observations of the ecological effects both of spilt oil and clean-up treatments have been made around its shores. It should not be assumed that such methods or data, even when they originate from the most reliable sources, are automatically applicable to other regions: as has been noted above, some are already known not to be so. The development of special techniques for arctic conditions, together with the acquisition of relevant biological data, is already proceeding apace in North America; tropical and subtropical waters seem generally to be much more neglected in this respect. There would appear to be a strong case for considerable expansion of scientific investigation of the marine environment in the Region, both fundamental and applied to problems such as oil pollution and the rationalization of fisheries. This could probably be handled by the marine science centres already existing or now being established there, although there may be room for a further such institution near the mouth of the sea area of the Region.

REFERENCES

- ANON. (1974a) Report of the State of Kuwait to the Twelfth FAO Regional Conference for the Near East, Amman, 31st Aug - 9 Sept. (short summary given in United Nations Food and Agriculture Organization (FAO) Bibliography, 1976).
- ANON. (1974b) Oil escapes at Getty wharves. Mar. Pollut. Bull. 5: 132.
- ANON. (1976) Working papers of the joint ESA/UNEP Field Mission to the common coastal region of Oman, United Arab Emirates, Qatar, Bahrain, Saudi Arabia, Kuwait, Iraq and Iran (unpublished).
- ANON. (1977) Superports and SBMs for tankers: Economic Study no. 55, London, H.P. Drewry Ltd.
- ANON. (1979) Crude oil supply and tanker demand: Economic Study no. 76, London, H.P. Drewry Ltd.
- ANON. (1980a) Oil spills - their fate and impact on the marine environment. Bermuda, OCIMF/London, IPIECA.
- ANON. (1980b) Interaction between the fishing industry and the offshore gas/oil industries. ICES Cooperative Research Report no. 94. International Council for the Exploration of the Sea, Copenhagen.
- BASSON, P.W., BURCHARD, J.E., HARDY, J.T. and PRICE, A.R.G. (1977) Biotopes of the Western Arabian Gulf. Dhahran, Arabian American Oil Company.
- BEYER, A.H. and PAINTER, L.J. (1977) Estimating the potential for future oil spills from tankers, offshore development and onshore pipelines. Proceedings of the Joint Oil Spill Conference, New Orleans: pp. 21-30 Washington D.C., American Petroleum Institute.
- BIGGS, H.E.J. (1973) The marine Mollusca of the Trucial Coast, Persian Gulf. Bulletin of the British Museum (Natural History), Zoology, 24: 341-421.
- BLEGVAD, H. and LOPPETHIN, B. (1944) Fishes of the Iranian Gulf. In Danish Scientific Investigations in Iran, pt. 3 (ed. K. Jessen and R. Sparck) pp. 1-247. Copenhagen, Munksgaard.
- COWELL, E.B. (1976) Oil pollution of the sea. In Marine Pollution (ed. R. Johnston) pp. 353-401. London, Academic Press.
- CRISP, D.J. (1976) Prospects of marine science in the Gulf area. UNESCO Technical Papers in Marine Science, 26: 19-38.
- DUBACH, H.W. (1964) Summary of temperature-salinity characteristics of the Persian Gulf. NODC-G-4, Washington, National Oceanographic Data Center.
- ENOMOTO, Y. (1971) Oceanographic survey and biological study of shrimps in the waters adjacent to the eastern coasts of the State of Kuwait. Bulletin of the Tokai Regional Fisheries Research Laboratory, no. 66.
- ERDMAN, D.S. (1950) Fishing in Arabia. Scientific Monthly (N.Y.), 58: 61-65.



- GIMSON, G. (ed.) (1980) Arab shipping: Seatrade Guide. Colchester, UK, Seatrade Publishing Co.
- GRASSHOFF, K (1976) Review of hydrographical and productivity conditions in the Gulf region. UNESCO Technical Papers in Marine Science, 26: 39-62.
- HAYES, M.O. and GUNDLACH, E.R. (1977) Oil pollution in the Arabian Gulf: a preliminary survey (unpublished; quoted by Neuman, 1979).
- HUSSEIN, N.A. (1975) Selected bibliography on the Arab Gulf oceanography and fisheries. Basrah, Centre for Arab Gulf Studies.
- JOHANNES, R.E. and BETZER, S.B (1975) Biotic response to pollution at different latitudes. In Tropical Marine Pollution (eds. E.J. Ferguson Wood and R.E. Johannes) pp. 1-12. Amsterdam, Elsevier.
- JONES, D.A., PRICE, A.R.G. and HUGHES, R.N. (1978) Ecology of the high saline lagoons Dawhat as Sayh, Arabian Gulf, Saudi Arabia. Estuarine and Coastal Mar. Sci. 6: 253-262.
- KASSLER, P (1973) The structural and geomorphic evolution of the Persian Gulf. In The Persian Gulf (ed. B.H. Purser) pp. 11-32. Berlin, Springer-Verlag.
- KINSMAN, J.J. (1964) Reef coral tolerance of high temperatures and salinities. Nature (Lond.) 202: 1280-1282.
- McLACHLAN, K and GHORBAN, N (1979) Economic development of the Middle East oil exporting States. Special Report no. 54 Economist Intelligence Unit, London.
- MOHAMMAD, M-B. M. (1971) Intertidal polychaetes from Kuwait, Arabian Gulf. J. Zool. (Lond.) 163: 285-303
- NELSON-SMITH, A (1972-3) Oil Pollution and Marine Ecology. London, Elek/ New York, Plenum Press.
- NELSON-SMITH, A. (1975) Effects of long-term, low level exposure to oil. In Petroleum and the Continental Shelf of North-West Europe, vol 2 (ed. H.A. Cole): pp. 105-111. Barking, UK, Applied Science.
- NELSON-SMITH, A. (1980a) A bibliography on the nature, application, effects and testing of chemicals used against oil spilled in the marine environment. London, IPIECA.
- NELSON-SMITH, A. (1980b) Biological consequences of oil spills in arctic waters. Paper given at the Arctic Committee/Royal Geographical Society Conference on the Arctic Ocean, London, 11th-12th March.
- NEUMAN, L.D. (1979) The protection and development of the marine environment and coastal areas of the Kuwait Conference Region. In Proceedings of the Joint Oil Spill Conference, Los Angeles : pp. 287-291. Washington, D.C., American Petroleum Institute.
- OOSTDAM, B.L. (1980) Oil pollution in the Persian Gulf and approaches, 1978. Mar. Pollut. Bull. 11: 138-144
- PRICE, A.R.G. (1979) Saudi Arabian Gulf shrimp resources. Proceedings of the Saudi Biological Society, 3: 293-302.

- PRICE, A.R.G. and JONES, D.A. (1975) Commercial and biological aspects of the Saudi Arabian Gulf shrimp fishery. Bulletin of Marine Research Centre, no. 6, Jeddah.
- PURSER, B.H. and SEIDBOLD, E. (1973) The principal environmental factors influencing Holocene sedimentation and diagenesis in the Persian Gulf. In The Persian Gulf (ed. B.H. Purser) : pp. 1-9. Berlin, Springer Verlag.
- SPOONER, M.F. (1970) Oil spill in Tarut Bay, Saudi Arabia. Mar. Pollut. Bull. 1 : 166-167.
- SPOONER, M.F. (1970a) Oil spill in Tarut Bay: follow-up observations (unpublished). Plymouth, Marine Biological Association.
- UNITED NATIONS FOOD AND AGRICULTURE ORGANIZATION (FAO) (1976). Bibliography of living marine resources, regional fishery survey and development project (Bahrain, Iran, Iraq, Kuwait, Oman, Qatar, Saudi Arabia, United Arab Emirates). Rome, FAO. FI: DP/REM/71/278/2.
- WENNINK, C.J. and NELSON-SMITH, A (1977) Coastal oil pollution evaluation study for the Kingdom of Saudi Arabia, vol 2: Gulf coast. London, IMO.
- WOLFE, D.A. (ed.) (1977) Fate and effects of petroleum hydrocarbons in marine ecosystems and organisms. New York, Pergamon Press.

BIOLOGICAL IMPACT AND EFFECTS ON FISHERIES OF OIL SPILL  
IN BAHRAIN, AUGUST-SEPTEMBER 1980

by  
O. Linden

Swedish Institute for Water and Pollution Research,  
Nykoping, Sweden

ABSTRACT

This paper takes the form of a report prepared under the terms of the IMO/FAO Advisory Mission to Bahrain, which took place while clean-up operations were in progress. Conclusions are arrived at concerning the biological impact of the spill and the effect of the spill on fisheries; the first being mainly the mortality of marine life as a result of smothering of organisms by residual oil in the inter-tidal zone and the effect due to the destruction of the fishing equipment and the prevention of fishing during the acute phase of the spill. The report lists the recommendations to the Bahrain Government concerning restrictions on the use of dispersants in shallow water and the need to avoid removal and replacement of oil contaminated sediments unless such oil was likely to recontaminate sections of the beach reserved for recreational use of fishing-related activities.

## BACKGROUND

A relatively large oil spill contaminated the coast of Bahrain during the last week of August and the first two weeks of September 1980. The oil reaching the coast contaminated almost the entire north and west coast.

At the request of the Government of Bahrain, IMO and FAO organized the present study with the purpose of assessing the impact of the oil spill. The terms of reference for the mission were to evaluate the biological damage caused by the spill and the clean-up operations and particularly to assess the damage to fisheries.

### PHYSICAL AND BIOLOGICAL FEATURES OF THE AREA AFFECTED BY THE OIL SPILL

The sea area of the Kuwait Action Plan (KAP) Region and the Gulf of Bahrain surrounding Bahrain in the north and west are characterized by extremely shallow waters. The depth figures in these areas are normally less than 10 metres and are in large areas between 0 and 2 metres. These shallows, consisting of sand, rubble, rock and coral reefs, form a barrier to tidal water movements and wind-driven wave action. The tidal water amplitude on the north-west coast of Bahrain is about 1.8m. The prevailing wind direction is southerly but, except in January-February, the winds are weak, normally below 5 m/sec.

The weak winds during spring, summer and autumn, in combination with the relatively low tidal water amplitude and the extensive shallow areas surrounding the Bahrain island, result in poor water exchange and relatively stagnant conditions close to the coast.

Salinities are high in the region, ranging between 35 and 50 ‰. The temperature of the nearshore waters ranges between 17°C and 33°C.

The coastline of Bahrain in the north and west is open and the beaches are generally composed of sand. In some areas mixed sand and rock beaches or rock beaches are found.

The biotopes in the shallow subtidal areas consist of coral reefs; either platform reefs in shallow water or fringing reefs along the shoreline, and rocky bottoms, grass beds and sand bottoms.

The coral reefs in the Bahrain area consist of a few, up to about fifty, species of corals. Usually the diversity is low close to land due to sub-optimal physical conditions. Associated with the coral reefs are a number of fish, crustaceans, polychaetes and molluscs. Generally, however, the diversity of associated species is lower than on reefs in most other tropical regions.

The rock bottoms around Bahrain are often covered with algal growth. Most of these are small, filamentous, red or brown algae. Various corals also occur on the rock bottoms and there is continuous competition for space between corals and algae on this type of substrate. Fish, crustaceans, polychaetes and molluscs are other dominating organism groups on these bottoms.

Sand bottoms or mixed sand, rock and coral bottoms cover large areas of the shallow subtidal zone north and west of Bahrain. Except for the grass beds the sand bottoms are inhabited by few plants or algae. However, a variety of burrowing animals (crustaceans, polychaetes and molluscs) occur in this environment.

Sand bottoms covered with sea-grass beds are common in Bahrainian waters. The dominating genera are Halodule and Halophila. The grass beds are extremely productive ecosystems and the plants form the basis for many of the food webs in this sea area. It is also an important nursery and attachment site for several species of direct economic importance such as shrimp, pearl oyster and several fishes.

#### BEHAVIOUR AND FATE OF THE OIL

The oil travelling from the north and north-west, driven by currents and winds, arrived at the coast of Bahrain on 25 August, 1980. From that day and for the following two to three weeks most parts of the north and west coasts were affected by the oil spill.

During the acute phase of the spill it was estimated that at least 20,000 barrels or about 3,300 tonnes of oil had accumulated on the Bahrain coasts or was still floating offshore. (Estimation made by BAPCO clean-up personnel). Generally it can be assumed that a crude oil from the area, released to the surface of the sea, will lose about 50 per cent of its volume due to evaporation during the first week.

The oil was transported with each rising tide towards the shoreline. This caused contamination of the beaches up to the highest tidal mark.

When the oil arrived at the coast it had low viscosity and was sticky. According to BAPCO clean-up personnel the oil looked surprisingly fresh and unweathered.

The oil deposited on the beaches adhered to driftwood, rubbish, algae and plants as well as to stones, rocks and sand. A considerable proportion of the oil could be removed by simply removing deposits of sea-grass on the beaches, as these acted as absorbing material.

The oil on sand beaches quickly penetrated into the sand. About one month after the spill, the sand was found to be contaminated down to a depth of at least 0.5 metres.

At low tide, oil trapped in the sand leaked out again, causing recontamination of already cleaned beaches. During the latter part of September this was probably the main reason for the contamination of beaches which had once been cleaned. The magnitude of this recontamination appeared to cause substantial problems in several places. Due to the poor water exchange caused by the weak winds and the relatively low tidal water amplitude, in combination with the shallow waters around Bahrain, the problems caused by the contaminated beach-sediments will probably remain for several months.

The oil that reached the splash zone, as a surface film or partly emulsified, adhered to or incorporated sand particles, detritus, etc. This, in combination with wave action, caused parts of the oil to sink as droplets surrounded by or incorporated in sand, detritus, etc. This oil accumulated in layers on the sea floor immediately offshore. The oil mixture, particularly if the detritus content was high and the sand content low, appeared as a very fine, light, brownish flock on the sea floor accumulated in ribbons parallel to the shoreline.

During the first part of September, spraying operations with oil spill dispersants were carried out off the Bahrain coast. Spraying was performed from helicopters in shallow waters, where the water depth was only 3-5 metres. Within 24 hours of dispersing an oil slick the oil had reportedly formed a new surface slick in the area. It seems likely that this was a result of the poor water exchange in this shallow area.

## BIOLOGICAL IMPACT OF THE OIL SPILL AND THE CLEAN-UP OPERATIONS

### Upper tidal zone

The large quantities of oil that were deposited on the upper parts of the beaches along the north and west coasts reportedly caused a drastic mortality among the fauna. Dead crabs and gastropods (snails) were observed in large numbers during the acute phase of the contamination.

At the end of September the crab (mainly Ocypode saratan) and amphipod populations on the upper parts of the shore were clearly reduced compared to unaffected areas. Large parts of the contaminated coast appeared to have lost their entire crab and amphipod populations.

The oil that reached the Bahranian coast had probably been drifting for several days on the sea. Consequently, the weathering effects on the oil under local conditions must have been substantial.

Therefore it seems likely that the acute mortality caused by the oil spill was mainly due to the physical effect of the oil, rather than to chemical toxicity. The physical effects of the oil that stuck to the organisms causing mortality were probably due to the clogging of mouth openings and breathing canals. It is also possible that the animals' movements were severely affected.

Considerable parts of the affected coastline are recreational and amenity beaches. The clean-up operations have involved removal of all contaminated sand using bulldozers, front-end loaders and other heavy machinery. It is clear that this intensive clean-up of the beaches has been an extra stress factor for the crab populations and other fauna of the upper parts of the beaches.

The period necessary for a complete recovery of the ecosystems of the upper tidal zone along all the affected shoreline is uncertain. In most places it seems likely that, within a relatively short period (months), surviving individuals from adjacent, less affected, or unaffected areas, will recolonize the empty areas through migration. However, judging from the fact that in some places even relatively long stretches of the beach have been left empty, it seems probable that complete recovery here is rather a question of years.

### Lower tidal zone

In certain areas this zone consists of a large, flat, tidal shelf of mixed sand and rock. The width of this shelf is several kilometres in some areas in the north. The ecosystem here does not appear to have suffered substantial damage due to the oil spill. Towards the end of September, molluscs, mainly gastropods, crustaceans, polychaetes and fish were abundant and no difference between affected and unaffected areas could be observed regarding the abundance of the most common species.

The oil, when it arrived at these tidal shelves, contained low quantities of readily soluble, toxic, aromatic compounds. It appears that the oil was only deposited during low tide and none or insignificant amounts penetrated into the sediments, until the next rise in tidal water when the oil was simply lifted and carried away on the surface. The fauna in this section of the beach has several adaptations to resist extreme stress during low tidal conditions. They either burrow into the sediment, cling tightly to a hard surface, or close themselves completely. These are probably the main reasons for the absence of apparent effects of the oil in the lower tidal zone.

#### Subtidal zone

The limited efforts that could be made during the latter part of September to assess the damage to the ecosystem in this zone did not reveal any apparent effects of the spill. No other observations are available that indicate that such effects have occurred. However, due to the importance of the extensive shallow areas north and north-west of Bahrain for the coastal productivity as a whole in Bahrainian waters and in other parts of the KAP Region, any impact of the oil spill in this area must be a matter of particular concern.

The clean-up operations involving dispersant spraying were carried out in extremely shallow areas (3-5 metres). It is well known that the addition of dispersants (regardless of type) means that the toxicity of the oil substantially increases. Environmental authorities in many countries even prohibit the use of dispersants, and dispersant manufacturers advise against the use of dispersants in shallow water areas where the dilution capacity is insufficient. In Bahrain, about 250 barrels of Esso Corexit 7764 oil dispersant were used.

#### Bird population

Considerable numbers of dead or dying birds were observed during the acute phase of the spill. Particularly on the island of Umm Nasan and from the Muhammadi areas, relatively large numbers of affected birds have been reported. Based on these reports, the actual number of birds that have died due to the oil spill may be as many as 1,000. The species that seem to have been most affected by the spill are common cormorants, and Socotra cormorants. The number of cormorants killed, although large in itself, does not seem large enough to produce any long-term effects on the populations of these species in the coastal areas of Bahrain.

#### IMPACT ON FISHERY

During the acute phase of the spill, observations of dead or dying fishes were made. On the beaches around the village of Al Malikiyah, dead groupers and jacks were reported, and offshore, fishermen reported groupers floating on the surface. In Matallah Bay in the south, considerable numbers of dead sardine-like fishes were observed on the beach and 678 specimens were counted on 400 m of shoreline. However, no massive mortality was reported in larger areas and no dead or dying fish that could be related to the spill could be observed in late September. On the contrary, shoals of seemingly unaffected juvenile fish, mainly mullets, were observed in the immediate vicinity of oil patches on the surface.

Reports of reduced catches of fish after the spill were received from some fishermen. However, other fishermen claimed that there had been no effect on catches. Using the fishery statistics, it is at present not possible to observe any indications of reduced catches. Only data from longer periods might reveal

long-term effects on the fish populations. No more than isolated cases of tainting of fish have been reported.

Fishing in the affected areas is mainly carried out using barrier traps, wire traps and gill nets. During the acute phase of the spill, considerable numbers of these types of fishing gear were heavily smeared with oil. The oil, sticking to nets, wires and ropes, caused the traps to collapse. Furthermore, it was often impossible to remove the oil without destroying the equipment.

During the period when larger slicks of oil were floating on the sea, the oil prevented fishing efforts in the area. This period lasted about three weeks.

At present it seems that the major effect on fisheries was caused by the destruction of equipment and the loss of catch during the acute phase of the spill. A total figure of 225,000 dinars (about 240,000 pounds sterling) has been calculated as the likely figure for these losses to fisheries. This estimate has taken into account the lower value for older equipment.

Additional losses to fisheries have been caused by the oil smeared on boats, clogging water-cooling systems in engines, etc.

Some additional losses may have been incurred by resistance among the public to the consumption of fish. This appears, however, not to have caused major problems as the prices of fish on the market have reportedly not dropped during the period after the spill.

#### SUMMARY

##### Behaviour of the oil

Under the prevailing environmental conditions in the Region it can be expected that the crude oil released on the surface of the sea lost about 50 per cent of its volume due to evaporation during the first week.

The oil arriving at the coast of Bahrain was deposited in the upper tidal zone. In several areas along the coast the oil has penetrated down to a depth of at least 0.5 m in the sand. Insignificant amounts appear to have penetrated to the bottom in the lower tidal zone or in subtidal areas down to 5 metres depth.

The oil accumulated in the sand on the beaches is relatively unaffected by degradation processes. Some of it leaks out during low tide. It seems likely that the process will continue for several months, causing some additional pollution.

The floating oil slicks in the splash zone adhere to and incorporate sand and detritus so that the density increases and the oil sinks. This mixture of emulsified oil together with detritus, etc. appears as a very fine, light, brownish, surface flock on the sea floor off the beach, accumulated in ribbons parallel to the shoreline.

The oil on the beaches that has stuck to hard substrates like stones, rocks, etc. has formed a hard surface, which, at the end of September, is no longer sticky and does not cause recontamination.



### Biological effects

Almost 100 per cent of the populations of beach-living crabs (mainly ghost crabs) and beach fleas or sandhoppers (amphipods) along the north and west coasts have been killed by the oil spill and the clean-up. This effect is particularly obvious on the stretches of the beach where the clean-up operations have involved removal of contaminated sand.

No significant mortality among the fauna and flora in the lower sections of the littoral and sublittoral zones or on the coral/sand reef at Fasht al Jarim appears to have occurred.

Sessile and semisessile organisms like barnacles and mussels on rocks, stones and jetties etc., that have been covered with oil, have died.

According to reports, between several hundred and one thousand birds, mainly cormorants have been killed by the spill. The Bahraini populations of cormorant consist of two species: the common cormorant (Phalacrocorax carbo) and the Socotra cormorant (P. nigroglaris).

### Impact on fisheries

During the acute phase of the spill, observations of dead fish were reported. Thus, dead jacks, groupers and sardine-like fishes have been observed, although no massive mortality has been reported. At the end of September no observations of dead or dying fish that could be related to the oil spill could be made.

In some areas the fish catches had dropped after the spill according to some fishermen, although others claimed that there had been no effect on catches.

The basic impact of the oil on fisheries in the Bahrain area appears to be due to:

(i) Destruction of fishing gear. Barrier and wire traps and gill nets that became smeared with oil were in most cases destroyed and had to be renewed;

(ii) Loss of catch. During the period when the oil was floating on the surface it prevented fishing in the area;

(iii) Contamination of other equipment. Boats, engines (water-cooling systems), ropes, etc. were smeared with oil and had to be cleaned before use.

A total figure of 225,000 dinars has been calculated as the likely figure for equipment destroyed and catch lost.

### CONCLUSIONS

The observations on the biological impact of the spill indicate that the damage was mainly caused by the physical effect of the oil (i.e. stickiness) rather than chemical toxicity.

The observations on the impact of the spill on fisheries indicate that the major damage was due to the destruction of equipment and the prevention of fishing during the acute phase of the spill. This damage appears to have been substantial.

The clean-up operations on the beaches involving removal of contaminated sediments aggravate the biological damage caused by the spill.

No obvious biological damage has been observed so far in the shallow areas where spraying of dispersants took place. The technique was, however, not effective due to poor water exchange in the shallow water.

#### RECOMMENDATIONS

Except on recreational beaches, no clean-up operations should be carried out involving the removal of contaminated sediments.

Clean-up operations on other beaches should be restricted to the removal of oil that is likely to cause recontamination.

Oil spill dispersants should not be used extensively on the beaches and in shallow water areas.

The gathering of statistical data regarding catches should continue, as this may reveal long-term effects on fish populations.

Samples of fish and filtering organisms should be analysed for oil contamination of tissues. Samples should, in particular, be collected from the areas where spraying with dispersants was carried out.

In order to assess the effects of the recent oil spills on the coral reef community a follow-up study is required. This investigation should consider the condition of the ecosystem in general. Particular attention should be given to the balance between coral polyps and the benthic algae. Measurements of bacterial growth on secreted mucus should also be carried out. The concentration of petroleum hydrocarbons on filtering organisms should be analysed.

SESSION II: POLLUTION FROM OFFSHORE EXPLORATION AND EXPLOITATION

5. Exploration and Exploitation of the Seabed for Oil-Biological Impacts in Perspective B. Dicks
6. Training in Oil Well Blow-Out Prevention and the Role of Simulators E. Hull
7. Oily Water Discharges from Offshore Oil Installations, Their Origin and Treatment and Some Examples of Their Regulation A.D. Read
8. Tailored Oil Spill Contingency Planning for Offshore Oil Blow-Outs J.Ph. Poley
9. August 1980 Oil Spill Clean-Up Project - Bahrain Report Summary of Task Force Operations D.J.S. Brown and A. Baxter
10. Oil Slick Movements in the Kuwait Action Plan Region W.J. Lehr and H.M. Cekirge
11. Computer Simulation of Oil Spills State of the Art Regarding Models and Applied Techniques F. Krogh
12. A Computer-Assisted Oil Spill Contingency Centre with Emphasis on Data Bases, Risk and Consequence Analysis F. Krogh

EXPLORATION AND EXPLOITATION OF THE SEABED FOR OIL  
-BIOLOGICAL IMPACTS IN PERSPECTIVE

by  
B. Dicks

Research Unit, OPRU,  
Pembroke, South Wales, U.K.

ABSTRACT

Offshore exploration for oil and its subsequent exploitation has become a world-wide industry, although restricted almost entirely to continental shelf waters and inland seas. It continues to expand at a considerable rate in response to ever-increasing world energy needs.

The biological impacts of such exploration and exploitation are of growing concern as the marine environment gains recognition as a long-term resource. This presentation outlines the sources of biological impacts from offshore developments and summarizes existing knowledge of oilfield effects. In addition, the fate and effects of crude oil in the sea and the factors which influence crude oil toxicity are discussed, with particular reference to tropical ecosystems.

It is possible to exploit offshore resources without the ultimate destruction of large sections of the marine environment, but this requires careful pre-planning, notably in terms of a better understanding of marine ecosystems and the way they function, and the application of this knowledge to early design stages to minimize impacts. Some approaches to the measurement of impacts offshore are explained in this context. In addition, there are urgent needs for planning of responses to oil spills and for further relevant research, especially in tropical ecosystems.

## INTRODUCTION

The exploration for oil in offshore areas and its subsequent exploitation has become a world-wide industry, mainly in response to ever-increasing world energy needs. This development has largely been restricted to continental shelf waters and inland seas, although it may in future spread to deeper waters.

In conjunction with oil and other industrial developments has come recognition of the biosphere as our only long-term resource. This principle has recently been highlighted by the publication of a 'World Conservation Strategy' by the International Union for the Conservation of Nature (IUCN), the United Nations Environment Programme (UNEP) and the World Wildlife Fund (WWF). The strategy basically involves three concepts: the understanding of the functioning of ecosystems, the use of this information to minimize damage by man, and careful management of the environment to maximize its usefulness to man. There is little doubt that we are a long way from realizing these objectives, but our present understanding does allow us to identify many sensitive and valuable ecosystems, which include tropical and subtropical marine systems. The sea area of the Kuwait Action Plan (KAP) Region, subtropical and almost completely landlocked, is the largest offshore oil development area in the world. There is little potential for unlimited dispersion and dilution of pollutants on a par with that of the open oceans and as such the sea area of the KAP Region deserves special attention in terms of oil and the marine ecosystems.

Offshore oilfields, which either comprise single platforms or large clusters of platforms, storage facilities, loading systems and pipelines, can justifiably be considered as fixed-point sources of pollution. Pollution can arise acutely, for example, as a large spill from a pipeline break or well blow-out, or chronically from continuous or intermittent operational discharges. This paper identifies types of discharge from offshore oilfields and discusses the components of the marine environment which they may affect. In the context of the KAP region it is important to realize that no offshore development is further than 150 kilometres from the shoreline, and the probability of acute pollution incidents affecting the coast is high. Coastal ecosystems are therefore considered in the context of impacts of offshore developments, and in terms of oil-spill response planning and long-term monitoring.

Before looking in detail at sources of pollution from oilfield developments, it is useful to consider the offshore and coastal marine environment in very general terms.

## THE OFFSHORE MARINE ENVIRONMENT

The offshore marine environment can be divided into three main zones - the sea surface, the water column and the seabed. Each of these zones has its complement of animals and plants functioning as a dynamic system, with interactions both between organisms and between organisms and their environment. There are no hard and fast boundaries between the three zones and they interact freely. The complexity of the interactions between organisms in the marine ecosystem is well established but many are poorly known. A grossly simplified web of the feeding relationships between the main organisms of the offshore ecosystem is given in figure I. It is convenient in constructing this to divide the organisms which lie in this system into six main groupings.

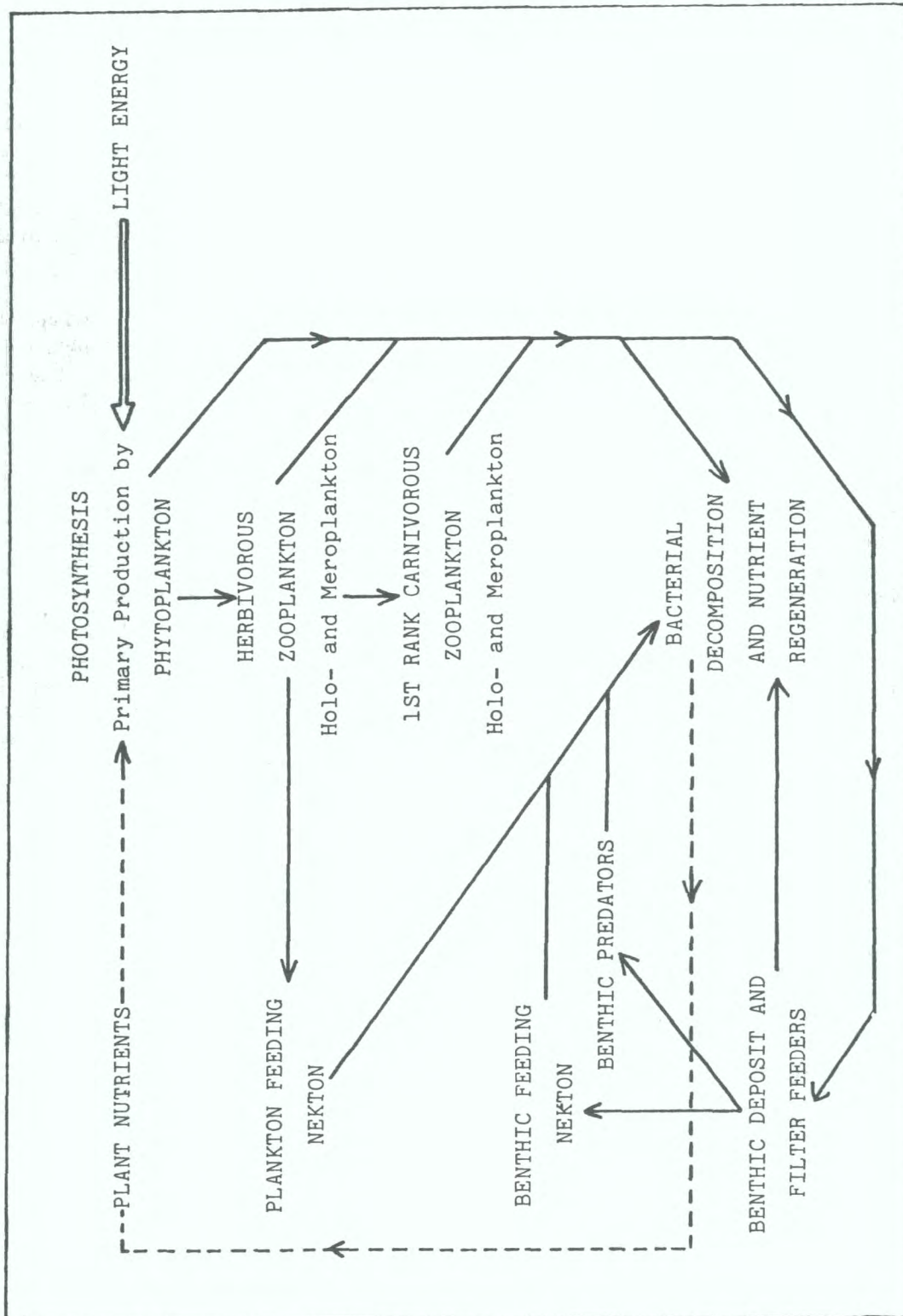

Figure 1: A simplified food web for the offshore environment

The plankton. Animals and plants drifting in the surface waters, many of which are microscopic. Of these organisms, phytoplankton (plants), which are primarily unicellular, form the primary producers. In temperate waters the phytoplankton grow seasonally, the highest productivity occurring in spring and autumn, with variable productivity in summer and lowest productivity in winter. There is a cycle of nutrient availability and utilization, and nutrients can become available in considerable quantities following mixing of the water column during the period of equinoctial gales. The sudden availability during turnover of nutrients may result in 'blooms' of algae which can colour the surface waters. In tropical and subtropical marine systems seasonal variation is much less marked, but cyclic uptake and release of nutrients can occur seasonally, or during natural recycling by growth of organisms and nutrient depletion followed by death and decomposition of organisms and nutrient release.

Many of the animals of the plankton (zooplankton) are herbivores, using the phytoplanktonic blooms as a food source. In turn, others of the zooplankton are carnivores, feeding on the herbivores and each other. Along with the permanent members of the plankton (holoplankton), many marine organisms have planktonic larval stages (meroplankton) which also take advantage of the high phytoplanktonic productivity of the surface waters.

The nekton. Large mobile organisms capable of travelling independently of water movements. These comprise the pelagic fish, mammals, cephalopods (squids) and other categories of powerful swimming invertebrates (e.g. prawns). These organisms may be dependent on the plankton, each other, or on seabed organisms for their foods.

The epibenthos. Those organisms that live on the seabed, some of which may be very active (e.g. fish), others of which may be slow-moving (e.g. gastropods, asteroids), whilst others may be static (e.g. mussels, bryozoans). These organisms may feed on the 'rain' of plankton to the seabed, on organic material in or on the sediments, or on each other.

Benthic infauna. The organisms living buried in the seabed, many of which are sedentary tube dwellers, or relatively slow-moving burrowers. Like the epibenthos they may filter-feed from the water above the seabed, deposit-feed on sediments, or actively prey on other organisms. Many exhibit multiple feeding patterns or may vary their feeding habits according to habitat type or the phase of their life cycle.

An important subdivision of the benthos is the meiofauna, that part of the fauna less than 0.5 mm in size.

Seabirds. Those species of bird which spend the majority of their lives on and feeding in the sea surface (e.g. auks, gannets).

Decomposers. Mainly marine bacteria and protozoans which recycle the nutrient materials by decomposing dead organic remains.

In each of these six divisions the organisms vary in their susceptibility to oil or other pollutants, some being more sensitive (e.g. fish eggs and larvae, Kuhnhold *et al.*, 1978), others more resistant (rocky shore gastropods such as Monodonta lineata, Crapp, 1971). It is evident that major pollution damage to one or more of the components of the simplified food web illustrated in figure 1 could have repercussions throughout the system.

## NEARSHORE AND COASTAL MARINE ENVIRONMENTS

Most of the groupings of organisms outlined above occur in nearshore waters or onshore, and they interact freely with offshore systems. However, in nearshore areas water is shallow, and may be very shallow at the interface between land and sea. This results in some specialized sets of environmental conditions related mainly to tidal or seasonal fluctuations in water level and consequently in some specialized community types, many of which are important as nursery areas or in marine food-chains. Of particular relevance to the Region are nearshore areas of coral, coastal lagoons, sea-grass beds and mangrove swamps.

Major differences become obvious when comparing onshore and nearshore systems with those offshore in the context of pollution, and this justifies their separate consideration here. The differences arise mainly as a result of two factors: firstly, the shallowness of nearshore waters results in limited dispersion capability for pollutants, and secondly, at the interface between sea and land (which may or may not be subject to seasonal or tidal fluctuation), floating pollutants like oil can collect in large amounts where they may be difficult to clean up and may cause extensive biological damage.

It is not the purpose here to consider in detail the impacts of oil in these systems, as this will be dealt with by other speakers at this meeting, but it is our intention to summarize sources and impacts of offshore pollution and factors which affect toxicity of spilled oil.

## OFFSHORE OILFIELD DISCHARGES

The presence of a platform or other structure either piled into or resting on the seabed has a number of immediate physical effects on the marine environment, followed later by a variety of effects as a result of discharges during construction, drilling and subsequent operation and oil production.

The possible sources of the impact of platforms on the offshore environment can be identified in nine sections as follows (Dicks, 1980; Shelton and Nicholls, 1974):

- The physical presence of structures and pipelines;
- Drilling;
- Cooling water;
- Produced water;
- Deck drainage;
- Domestic wastes;
- Well, pipeline and storage facilities - corrosion protection chemicals;
- Shipping activities;
- Wellhead blow-outs and other large spills;

and will be dealt with separately.

The physical presence of structures and pipelines

Placement of a steel jacket, concrete storage structure or platform on the seabed results in either severe local disturbance of the sediments, or in the latter cases, obliteration of an area of the seabed. The disturbed sediments then resettle around the structure and may cause environmental changes. It is well established



that seafloor communities are ultimately related to sediment composition (Jones, 1950; Thorson, 1966; Thorson, 1971; Glémarec, 1973). These changes may either be subtle, short-lived and localized (the sediments subsequently being recolonized or the animals present re-establishing their burrows), or they may be longer-lived as a result of permanent washing-out of fine sediments from an area and resettlement by new species as a consequence of sediment changes. The laying and trenching of pipelines results in similar sediment redistribution and can therefore induce changes in the seabed fauna. It is to be expected that such changes would be localized to within a few metres of the structure, except perhaps where the velocity of currents is naturally great or increased by the presence of the structure.

The presence of the platform may also locally modify current patterns and water movements, thus modifying local microhabitats, and of course is a large, artificial, hard substrate available for colonization. This 'artificial reef' rapidly colonizes with a variety of fouling organisms (Wolfson *et al.*, 1979) whose larvae settle from the plankton. These organisms then attract shoals of fish to feed. In the Gulf of Mexico this sort of reef effect has been regarded by local sport fishermen as a distinct environmental improvement (G.U.R.C., 1974). The accretion of detached fouling organisms on the seabed around the base of a platform has been shown to produce an increase in diversity of communities around a platform in Southern California (Wolfson *et al.*, 1979).

All such localized physical changes, together with the ingress of fouling species and those species feeding on them, serve to modify the environment and alter the feeding relationships of the area.

The 'artificial reef' effect is not limited to the structure itself, or to unburied pipelines. Whatever activity occurs, especially during construction, pieces of equipment, lengths of chain, wire hawser or ropes, anchors, pieces of steel or pipe and so on, will inevitably be lost to the seabed. These are particularly difficult to reclaim from relatively deep water and if left will form small 'artificial reefs' with their own localized effects. Thus the physical impact of the developments offshore can be more or less widespread through an oilfield and will depend upon the degree of activity in the field.

Fouling growths can be a considerable nuisance as they present a number of problems to platform design and maintenance. During design a safety factor is built in to allow for increased loading of the structure by marine growths, but after construction the presence of the growth greatly hampers underwater inspection work and maintenance. Where vital work needs to be carried out, where welded joints have to be inspected, or when general inspection needs to be undertaken, the growth must be cleaned away mechanically, an expensive and lengthy diving operation. There is currently, therefore, a growing interest in the importance of marine fouling growths and their control (Freeman, 1977).

### Drilling

Subsequent to the initial placement and construction, drilling commences, and anything up to fifty wells may be drilled from a single platform. Discharges to the sea during drilling comprise the rock cuttings from the well and that proportion of the drilling mud which remains adhering to these cuttings. Although washing procedures are carried out to separate the muds from the cuttings, some of the drilling mud is inevitably lost or discharged overboard.

Drilling muds are a complicated and variable mixture of agents allowing adjustment of viscosity, density, and lubricating properties (for the drill string and bit) and perform the important function of transporting away rock cuttings and

drill wastes. Knowledge of the toxicity of muds is limited, but is summarized in a recent Symposium Proceedings (Lake Buena Vista, Florida, 1980). Some used muds have been shown to be toxic to corals (Thompson and Bright, 1977).

The cuttings and drilling mud solids will physically change the seabed environment over an area downcurrent of the platform by smothering the fauna or changing the sediment particle size distribution. This may result in changes in the fauna and flora of the seabed, the extent of which will depend upon the number of wells drilled, the speed with which they are drilled, and the current regime of the area. In general, neither rock cuttings nor water-based drilling muds have been shown to produce major detrimental change around offshore platforms, but it should be stressed that few biological data are available.

#### Cooling water

Sea-water is in some cases used to cool machinery during oil production and is normally returned directly to the sea. Thermal effects have been noted around various land-based discharges but little is known of the effects of platform discharges. Thermal effects are quite possible in the plankton and on fouling growths, particularly near the sea surface.

#### Produced water

During oil production, water contaminated by oil arises from two main sources: water in the formation produced with the oil, and displacement water from oil storage facilities.

Crude oil and gas in the reservoir are usually found in association with salt water or a salinity some two to four times that found in the sea. Inevitably some of this water will be produced with the oil, the amount increasing as the reservoir becomes depleted of oil. Koons *et al.* (1975) cite some laboratory and field studies which demonstrate that produced water is of a low order of toxicity, and the impact will ultimately depend upon the degree of treatment and the dispersion in the sea-waters around the structure. Primary effects of the water are related to oil content (treated to 50 ppm or less before discharge in the North Sea), salinity (usually 25 to 40 ‰), temperature, trace elements and the total produced volume. Displacement water from storage facilities is also treated to 50 ppm separable oil or less. In addition to this, both streams can be expected to contain soluble oils. The majority of the oil in the effluent is in the form of small droplets, and in this form the oil is most readily widely dispersed and most rapidly biodegraded (Hughes, 1976).

These oils in produced water may have direct toxic effects, or rain to the seabed attached to particles and become incorporated in the seabed sediments, where the immediate and longer-term effects will depend ultimately on the type and amounts of hydrocarbon arriving and the rate at which it degrades. Degradation is considerably slowed or stopped when oil is trapped in anaerobic sediments (Sanborn, 1977; Mayo *et al.*, 1978).

#### Deck drainage

Rain falling on the platform decks ultimately reaches the sea via the deck drainage system. In certain areas this water can pick up spilled pollutants (for example, drilling muds or chemicals, crude or lubricating oils) or emulsified 'oils' from the cleaning of machinery. In those areas where such spillage is possible, the streams should be segregated and treated to the same standard of separable hydrocarbons as the produced water effluents, although some dissolved chemicals and

dissolved and emulsified oils reach the sea from this source. The effects of these are likely to be similar to those of produced water and would not be separable from them.

#### Domestic wastes

During the early drilling and construction phases, the manning of a platform is at its maximum, and this means that peak amounts of both sewage and garbage are disposed of. The amounts decrease to a steady rate during the later production phase when numbers of personnel are reduced to a more or less constant operating level.

Food waste and a certain amount of grease are normally macerated and discharged to the sea, and solid matter, for example tins, bottles and the majority of the grease, may also end up in the sea or may be collected and returned to the shore. 'Grey' water from showers, baths, wash handbasins and laundering is often discharged untreated to the sea with its content of soap and detergents.

Domestic sewage from platforms in the North Sea normally undergoes primary activated sludge/aeration treatment, the supernatant being discharged to the sea. At intervals of two or three months the build-up of sludge in these units may be discharged to the sea.

The impact which such effluents have offshore is unlikely to be similar to the occasionally disastrous effects of organic enrichment manifest in a confined freshwater environment or even an estuary. The scale of the problem is very different from that on land where sewage from huge conurbations may pass to one receiving river or estuary - offshore approximately 100 to 300 men on a platform during peak manning and usually continually replaced water body. A likely biological impact could be nutrient enhancement of the waters immediately around the outfall, stimulating greater fouling growth on the structure, and of addition of nutrient to the plankton, thus stimulating planktonic growth at some point downcurrent of the platform. Under normal conditions of water mixing such growth stimulation is unlikely to place a significant oxygen demand on the water column and result in local deoxygenation.

#### Well, pipeline and storage facilities - corrosion protection chemicals

At some stages of pipeline construction and well completion the structure, pipework and oil storage tanks are not in contact with crude oil, but contain sea-water. For example, pipelines after construction, but before filling with crude, may be stabilized and pressure-tested. Treated sea-water may be pumped into oil reservoirs to maintain production pressure, and is often used offshore as the water phase of oil storage facilities which rely on displacement of water by oil. Under these conditions oxidative or other corrosive attack of steelwork occurs unless the water is treated. Preventative chemical treatment normally takes the form of addition of an oxygen scavenger, for example sodium sulphite, to prevent oxidative attack of steel or oxidative bacterial growth and a coating type of corrosion inhibitor (e.g. amines or organic sulphur compounds) which adsorbs on to the steel surfaces (to minimize corrosive attack by salts). In addition a biocide is added to prevent the growth of anaerobic bacteria, and in particular the sulphate-reducing bacteria which produce  $H_2S$  from the abundant sulphate in sea-water and which cause rapid deterioration of steel.

Spent treating chemicals are usually discharged to the sea, but little information is available on toxicity. Biological effects may result from direct toxicity to the plankton and benthos in a localized area around the dispersal point,

the outer limit of the area being determined by the rate of dilution to a non-toxic level. Impact could be expected to be reduced by careful selection of the types of chemicals used, careful control of volumes used and the selection of optimum conditions for dispersal during discharge.

Discharge of such chemicals is normally intermittent, most pipelines receiving treatment only once in their lives. Oil storage tanks filled intermittently with displacement water may present different problems. Where the displacement water (discharged during oil production) turns over regularly, it is unlikely to suffer an oxygen depletion and subsequent H<sub>2</sub>S production. Under other conditions where turnover is reduced or stops (for example during low production, where production equals export, or during shutdown), water may stagnate and require treatment. Such discharge of chemicals may be occasional or become regular and constitute a chronic pollution problem.

#### Shipping activities

Large numbers of supply vessels, working boats, standby vessels, barges and oil tankers pass through or spend time in offshore oilfields during their lives. Each ship contributes garbage, sewage and hydrocarbon pollutants to the water column and may also cause disturbance of the seabed by repeated anchoring activities, resulting in redistribution of sediments with accompanying localized environmental change.

#### Wellhead blow-outs and other large spills

Major spillage of oil resulting from blow-outs or other sources fortunately occurs infrequently, but can produce oil spills of considerable size over a period of time. For example, the Ekofisk Bravo blow-out in the North Sea spilled some 15-22,000 tonnes of crude oil over seven and a half days (Grahl-Nielsen, 1973), whilst the Ixtoc 1 blow-out in the Gulf of Mexico which started on 3 June 1979 was estimated to be spilling initially between 10 and 30,000 barrels of oil a day which subsequently decreased to around 2,000 barrels a day (OSIR, 1979; Bourne, 1979) and was eventually stopped in early 1980.

The same processes which act on oil spilled from ships also, of course, apply to blow-outs, and the total biological impact will depend on many factors, but, as for spills, mainly on the type of oil, the rate of spillage, weathering rate, rate of spread, the degree of natural or chemical dispersion and the type of receiving environment affected.

Even in relatively deep water fresh oil from a blow-out can reach the seabed, for example in Ekofisk (Johnson *et al.*, 1978) and the Bay of Campeche (Morson, 1979) where the processes of adsorption to particulates as well as emulsification were thought to be involved.

### DISCUSSION: THE BIOLOGICAL IMPACTS OF OILFIELDS AND OIL SPILLS

It is clear that the biological effects of offshore developments are many and varied, and that oil is only one contributor. Physical disturbance, 'artificial reef' effects, sewage, garbage hydrocarbons and other toxicants will all make contributions of varying magnitude which are either synergistic or antagonistic towards the final impact. The sources and receiving environments discussed above are summarized diagrammatically in figure II.

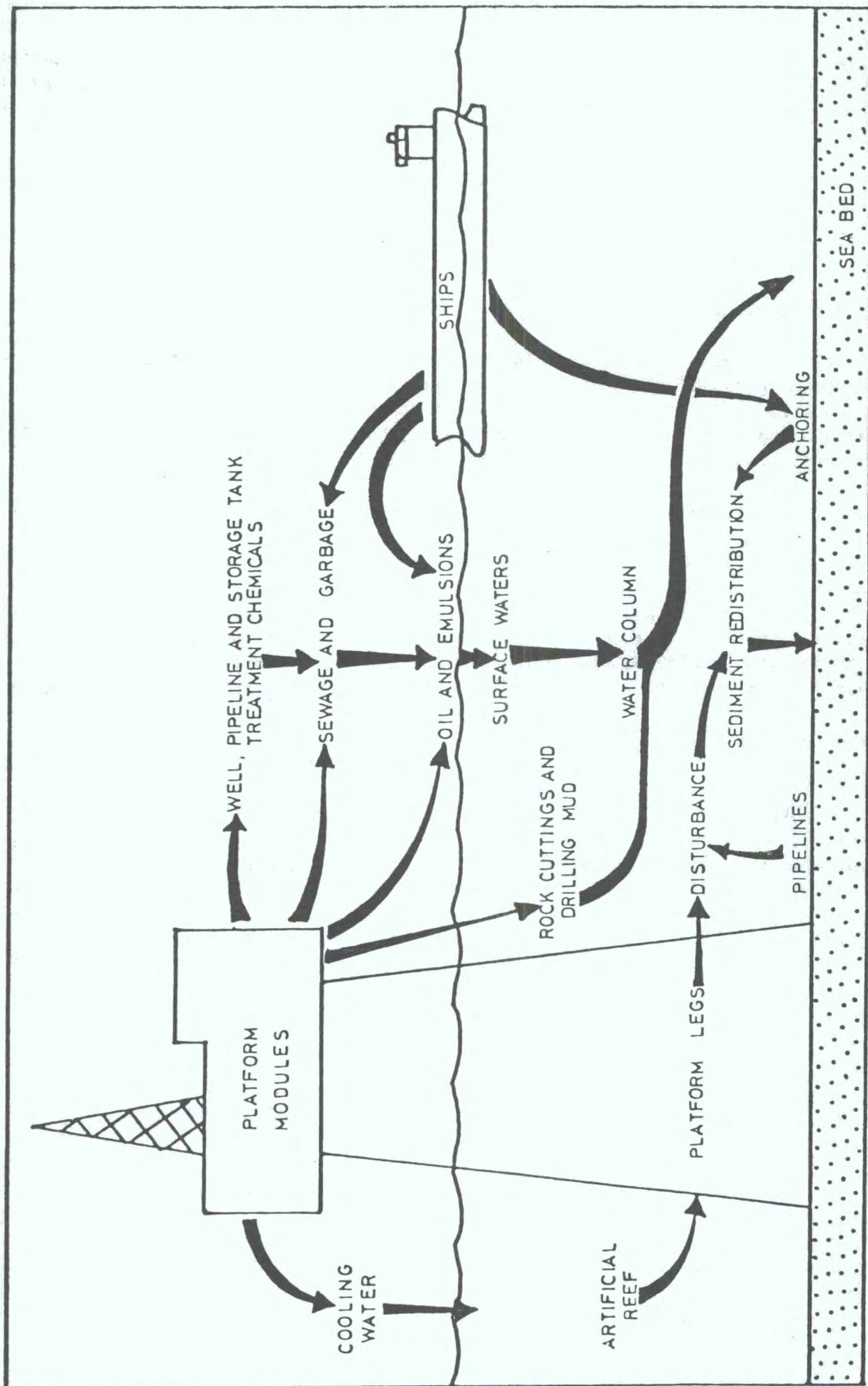

Figure II: Discharges from platforms, a diagrammatic summary

It is also clear that the impact of pollutants or disturbance is not limited to any one section of the offshore, onshore or nearshore environments. Oil may remain at or near the water surface, accumulate onshore or may sink by various means to the seabed. Dissolved oil, dispersed oil or suspended droplets, chemicals, sewage and garbage may enter the water column at any water mass by a thermocline. Rock cuttings, drilling muds, garbage, sewage solids, absorbed or emulsified oil may sink or be carried to the seabed and be variously reworked or redistributed by oilfield activities, storms or currents, or the organisms themselves, all of which will ultimately determine the final impact.

It is thus of limited value to attempt to assess or predict the impacts of offshore oilfields by estimating the amount of oil entering the sea from this source. Several estimates of oil inputs from offshore sources have been made, e.g. Shelton and Nichols (1974), Grossling (1976), Wardley-Smith (1976) and Clark and MacLeod (1977). The summary table from Clark and MacLeod is summarized here (table 1). As a percentage of total oil inputs to the world's oceans, offshore inputs (excluding natural seeps) have been estimated to be between 0.3 per cent and 3 per cent. Of this offshore input, Shelton and Nichols estimate that some 0.4 per cent occurs in the KAP Region. Taking the US National Academy of Sciences prediction for 1980 of c. 2,000,000 tonnes of oil lost to the sea from offshore operations, it is likely that c. 8,000 tonnes of oil will enter the waters of the Region in 1980. In real terms it is impossible to relate this figure to the ability of organisms or systems to cope.

Table 1. Sources of petroleum hydrocarbons in the marine environment.  
(After Clark and MacLeod, 1977.)

	Estimated input of oil per year (metric tonnes)		
	Estimate by Wardley-Smith (1971)	Nat. Academy of Sciences	Prediction by Nat. Academy of Sciences for 1980
Land-based discharges			
Refineries	300,000	200,000	20,000
Waste oils, runoff & sewage	500,000	2,500,000	2,400,000
Marine operations			
Tankers using LOT*	100,000	310,000	200,000
Tankers not using LOT*	600,000	770,000	
Drydocking	-	250,000	300,000
Bilge discharges	50,000	500,000	
Marine accidents	200,000	300,000	150,000
Offshore production	150,000	80,000	200,000
Natural seeps	-	600,000	600,000
Atmospheric fall-out	-	600,000	600,000
TOTALS	1,900,000	6,110,000	4,470,000

LOT = Load on Top - a procedure for reducing discharge of oil tank washings to the sea.

## The fate of oil in the sea - the role of biodegradation

It has long been established that the marine environment can cope with certain amounts of biodegradable material such as oil (Koons and Monaghan, 1976) without undue harm or economic consequence. In the case of hydrocarbons the marine environment shows many adaptations for dealing with them, for hydrocarbons occur naturally in both animal and plant cells. Although mineral (petrogenic) hydrocarbons differ from natural (biogenic) hydrocarbons in many ways (Clark and Brown, 1977), similar biological mechanisms may be involved in their uptake and degradation. However, a particularly important difference is that much higher proportions of low molecular weight homologous series of alkanes and aromatics occur in mineral oils. Many of these are toxic, partly as a result of water solubility, and partly as a result of the ease with which they penetrate cells (Clark and Brown, 1977; Baker, 1979), and many are not readily biodegradable. There is also a direct correlation between solubility and toxicity of many hydrocarbons, but other factors also influence toxicity such as degree of dispersion, degree of weathering, the presence of photo-oxidation products, temperature and organisms' susceptibility (Baker, 1978; Dicks and Baker, 1979).

The primary mechanism by which hydrocarbons are degraded in the sea takes the form of bacterial attack (Hughes, 1976). Many species of bacteria are capable of metabolizing both biogenic and petrogenic hydrocarbons ranging from the low molecular weight alkanes and aromatics to high molecular weight components. In addition to primary degradation, some invertebrates and vertebrates have been shown to possess mechanisms for dealing with a range of hydrocarbons. Varanasi and Malins (1977) summarize numerous examples: for example, the oyster, Crassostrea virginica, after taking up 312 ppm of dispersed No.2 Fuel Oil following eight hours' exposure was able to slowly depurate to 1.5 ppm of residues after 56 days; the mussel, Mytilus californianus, has been shown capable of depurating 99 per cent of mineral oil contamination in four days; and the clam, Rangia cuneata, capable of per cent depuration of No.2 Fuel Oil in between 10 and 56 days.

The mechanisms of depuration have been and are the subject of numerous studies, and have been shown to range from simple release or flushing back to the water column to enzymatic degradation. A wide range of marine organisms have been shown to possess the 'mixed function oxidase' system by which such degradation is thought to take place (Varanasi and Malins, 1977). Some examples are the elasmobranch, Raja erinacea, the clam, Mya arenaria, and a variety of planktonic organisms. Although the range of organisms possessing the enzymatic system for hydrocarbon breakdown is large, it has not been demonstrated conclusively that all mineral hydrocarbons can be metabolized, nor has the relative importance of metabolic or non-metabolic depuration been determined.

In some areas of the world, natural seeps of oil have occurred at low levels for many hundreds of years (Koons and Monaghan, 1976), and the local ecosystems cope, without apparent change in macrofaunal community structure, even where sediments are heavily polluted (Straughan, 1977). Whether such adaptation is a result of short-term selection of resistant individuals or a result of genetic change is not known. In spite of such evidence it is important not to become complacent about the ability of the sea to cope. It has been clearly demonstrated that in some habitats degradation rates are very low indeed. Atlas et al. (1978) report that microbial breakdown of oil trapped under arctic ice is almost negligible. Sanborn (1977) and Mayo et al. (1978) have shown that once oil is trapped in anaerobic marine sediments it degrades only slowly.

The ability of natural systems to cope with oil, discussed above and sometimes referred to as 'receiving capacity', underlies British legislation on setting of

discharge concentrations offshore (Read and Blackman, 1990). However, in no case is the real 'receiving capacity' of any marine environment precisely known, and most discharge concentrations are set either on the basis of laboratory toxicity test results or by extrapolation from one site where effects are apparently acceptable, to another. Where it is obviously good sense to utilize such 'receiving capacity', these are not reliable criteria on which to base decisions. Although the fates of many hydrocarbons in the marine environment are known, our knowledge is far from complete, and continued research into the fate and effects of hydrocarbons is essential. This is particularly so for those compounds which may not degrade or degrade only slowly.

#### Offshore impacts

The release of oil or other pollutants into the sea can occur either at or below the water surface. In the case of oil on the water surface, concentrations of water-soluble elements or dispersed droplets are likely to be greatest near the oil/water interface. Published information on oil concentrations under surface slicks or films is, however, very limited. Measurements that are available (for example, Law, 1973; Grahl-Nielsen, 1973; Cormack and Nichols, 1977) provide information on the metre or so below the surface rather than on the interface area. Reported concentrations are thus unlikely to be the maximum to which planktonic organisms could be exposed. The range of the case of the Ekofisk blow-out, where considerable amounts of crude oil and emulsions remained on the sea surface, water column levels were low but detectable, being less than 1 ppm level (Buckley and Humphrey, 1979) up to 50 ppm (Cormack and Nichols, 1977).

Oil-in-water concentrations in the 1 ppm or sub-ppm range have rarely been shown to induce mortality in adult marine organisms, but larvae and eggs are much more susceptible (Kuhnhold, 1972; Kuhnhold *et al.*, 1978), and these juvenile stages of course form an important part of the surface plankton. In addition to mortality, the induction of metabolic or behavioural change by sublethal concentrations of oil cannot be ignored, as they can result in considerable change in ecosystems. A good example is that of the detachment response of the common European limpet, *Patella vulgata* (Dicks, 1973). Oil acts as an irritant to the foot of the limpet, causing it to detach from the rock surface.

Detachment subsequently results in mortality from predation. This then has further repercussions for the rocky shore ecosystem as the limpets are no longer able to graze away algal spores. The shore then becomes dominated by algae, in turn producing further change. Hyland and Schneider (1976) provide an excellent summary of sublethal effects in response to oil that have been reported in the literature. Such effects range from respiratory stimulation or inhibition, growth inhibition, to the alteration of social or sexual behaviour or the induction of disease.

Although it is evident that the immediate impact of oil is likely to be on the water column inhabitants, it is particularly difficult to assess such impacts. The background of natural seasonal variation in these systems, which can be large (Hardy, 1956; Fraser, 1971; Raymont, 1963), the mobility of water masses, the patchiness in spatial and temporal distribution of organisms and difficulties with quantitative sampling make the identification or isolation of pollution effects from natural variation very difficult. Of particular concern is the fact that natural mortality in the plankton is high. Pollution stress, which might increase mortality, could result in tipping the balance towards a steady decline for some species. Such trends could easily go undetected until too late. We are thus in the frustrating position at present of recognizing the problem whilst being unable to predict or measure the impact of oil pollution on these 'front-line' receivers.



In the case of the nekton, the mobility of these organisms makes them particularly difficult to sample quantitatively. Like the plankton, their spatial and temporal distribution is variable, and, once again, pollution-induced variation is almost impossible to isolate from natural variation. Matters are further complicated by possible effects of overfishing, about which little is known. Like the fish and plankton, marine and maritime bird populations are variable, hard to quantify, mobile and particularly at risk from oil floating on the sea surface. Croxall (1975), Cramp *et al.* (1974), Bourne (1977) and the RSPB (1979) summarize the effects on birds and the problems of quantitatively sampling them.

It is clear that the above-considered groups of plankton, nekton and birds would be difficult to use as reliable and sensitive monitors of the impact of offshore pollution, in spite of their undoubted susceptibility and biological or economic importance.

In some cases the benthic macrofauna can provide or has provided useful indicators of pollution impact on the general biological health of an area (Sharp *et al.*, 1979; Addy *et al.*, 1978). Natural variation in benthic communities has long been established and can be high (Buchanan *et al.*, 1978; Rees *et al.*, 1977; Parker, 1975) but it is important that benthos can be sampled quantitatively and reliably, and information is slowly becoming available on the impact of offshore operations on benthic communities. It has already been established here and elsewhere (Addy *et al.*, 1978) that the total impact of offshore operations results from far more than just oil pollution, and the macrobenthos has proved useful as an indicator of area of impact. Effects so far reported vary from no detectable impact (Hartley, 1979) to a clear zone of effect (Addy *et al.*, 1978) attributable to several factors in addition to oil. During the Ekofisk blow-out some oil was reported to have become incorporated into seabed sediments (Johnson *et al.*, 1978) at sites ten miles or more from Platform Bravo, with reported concentrations ranging from 8 ppm to less than 1 ppm. Such concentrations are unlikely to produce significant changes in benthic macrofaunal communities. Addy *et al.* (1978) report higher hydrocarbon levels in sediments close to the structures in the Ekofisk Field (10 to 100 ppm range) and these correlated well with a zone of biological effect. The authors were unable to distinguish effects solely attributable to the blow-out.

It is hoped that in the near future more information will become available on the blow-outs in the Bay of Campeche (Ixtoc 1) and the Niger delta, for biological studies are in progress in these areas.

In summary, studies carried out up to the present have shown that operational impacts of offshore oilfields have been either difficult or impossible to detect, or have taken the form of localized community change in the immediate vicinity of platforms and storage tanks. Likewise the impacts of blow-outs in deep water offshore have been hard to detect. It is likely, therefore, that offshore oilfields do not represent a significant environmental threat, a conclusion also reached by Read and Blackman (1980). In spite of this, complacency should be resisted and biological surveillance of offshore activities maintained for the present, at least until data are available over a longer period of offshore production (c. 10-15 years).

#### Shores and nearshore shallow waters

In contrast to the offshore environment, there is a daunting volume of studies defining biological impacts of spills in nearshore waters and on the shore. Effects range from severe biological damage to actual growth stimulation of some intertidal plants. Most of these studies, however, concern temperate or cold regions of the world, and tropical ecosystems have received relatively little attention. It is

worth considering briefly the special problems of coastal environments in the KAP Region following a major spillage.

In the Region large areas of shallow tropical seas with areas of coral, coastal reef-bound lagoons, sea-grass beds, intertidal sand and mud and mangrove swamps are potentially at risk from spilled oil. Although relatively little is known of the basic functioning of these ecosystems, the sensitivity to oil pollution of coral reefs (Loya and Rinkevich, 1980; Ray, 1990) and of mangroves (Baker *et al.*, 1980) is well established. The economic value of shallow tropical seas and mangroves is also well established in terms of production of fish, shellfish, seaweed products and mangrove products, although reliable statistics are difficult to obtain and much subsistence fishing goes unreported.

Much of the volume of literature on spill effects in temperate waters is not readily applicable to tropical systems because of the large number of ways in which shallow tropical marine ecosystems differ from their temperate counterparts. Quoting Baker (in press):

"For example, some mangrove swamps, tropical sea-grass beds and coral reefs have higher gross primary productivities (estimated at 20,000 Kcal m<sup>-2</sup> yr<sup>-1</sup> or more) than other marine or terrestrial communities (e.g. grasslands and pastures estimated at 2,500 Kcal m<sup>-2</sup> yr<sup>-1</sup>, boreal coniferous forests 3,000 Kcal m<sup>-2</sup> yr<sup>-1</sup>, fuel-subsidized (mechanized) agriculture 12,000 Kcal m<sup>-2</sup> yr<sup>-1</sup>, and the open ocean 1,000 Kcal m<sup>-2</sup> yr<sup>-1</sup>). There may, however, be very little net community productivity because nearly all the gross primary productivity is dissipated through the respiration of the producing plants themselves plus that of complex webs of consumers. Odum (1971), the source of the above figures, describe such systems as steady state rather than growth ecosystems; they tend to have a high diversity of species with complex inter-relationships. Sanders (1968) calls them biologically accommodated communities, developing the idea that more or less constant physical conditions over long periods of time lead to complex communities of large numbers of specialized species. Speculation about the resistance to pollution and disturbance of such communities falls into two main categories, (a) that they will be less tolerant of pollution than more physically controlled communities (such as those of temperate estuaries) because the component species have narrower physiological tolerances, or (b) that their high diversity confers 'stability' through some sort of buffering effect. The available data do not, however, fit any general pattern. The effects of pollution or disturbance upon any particular community must surely depend upon a wide range of factors not all of which are related to diversity. However, it should not be assumed that all tropical communities are biologically accommodated and of high diversity. Perhaps, for example, the shallow seas near the Niger delta are so variably and sometimes heavily flooded with low-salinity sediment-rich water coming down the Niger that the benthic communities of offshore Nigerian oilfields are physically controlled. If so, these communities should be able to cope reasonably well with at least the physical disturbance aspects of oilfield activity..."

Other factors may also vary; there is unlikely to be an overall flushing with fresh water in the sea area of the Region from river input or rainfall such as is found in, for example, the Baltic. Evaporative losses probably prevent such turnover and hence the sea area of the Region could be considered an almost-closed

system. However, in warmer temperatures it is likely that biodegradation occurs at a greater rate than in temperate waters, and that the potential for accumulation of toxic fractions of oil is thus reduced. Quoting Baker again:

"...Generalizing, it may be predicted that acute, local effects of pollutants will be more severe in the tropics, but that accumulation of many pollutants (including petroleum hydrocarbons and many constituents of refinery effluents) is less likely to be a problem. If, however, the acute local effect of a particular pollutant happens to be the destruction or disruption of a complex biologically accommodated community, recovery may take a long time for inherent biological reasons, regardless of how long the pollution persists..."

For example, recovery of damaged mangrove systems has been estimated to take about thirty years (Chapman, 1977) or more.

Having established the complexity and economic importance of tropical and subtropical marine ecosystems and in some cases sensitivity to oil, it is important to consider the problems of design of biological survey programmes in relation to new developments, monitoring, post-oilspill responses and damage assessment.

#### ENVIRONMENTAL IMPACT ASSESSMENT, BIOLOGICAL SURVEYS AND MONITORING

The needs for environmental impact assessments, post-spill surveys, damage assessment and long-term monitoring schemes are increasing world-wide, not least in the KAP Region. Such studies may be treated as isolated or 'one-off' events by individual companies, but in fact they form a continuum which starts at the point where the questions "If a resource is developed at this point will major environmental damage result?" and "Given that development will go ahead, how can environmental impact be minimized?" are posed. Following this it may be asked "How can impacts be monitored over a period of time?" or "What damage has resulted from Spill X?". More often than not the earlier questions have never been posed, and the continuum is entered at the point defined by the last question. Notwithstanding this, such simple questions give biologists the starting point for defining objectives for biological studies, and their responses must be tailored to allow these questions to be answered as precisely as possible. In some cases this may require expensive multi-disciplinary studies where particularly complex systems occur, or may involve the careful selection of known 'indicator species' or sensitive systems for study and correlation with pollutant concentration. A very simple flow chart of a series of possible interactions between biologists and the oil industry is given in figure III.

Three very important points arise from the flow chart. Firstly, 'one-off' field surveys (descriptive or otherwise) do not necessarily identify all important environmental factors. For example, many sandy intertidal areas of the KAP Region are poor in fauna and, as a result of brief descriptive survey, might receive a low priority rating in terms of protection from spilled oil or its clean-up. However, some of these sandy beaches at certain times of the year are used by turtles for egg-laying, and these animals are considered by the IUCN to have a high priority for conservation. They must therefore be included in spill response plans, and the priority ascribed to these beaches during the turtle breeding season would be very high. A short descriptive survey would in most cases not be able to identify good turtle beaches, and here the investigation of literature and local knowledge assumes greater importance. In general terms it is often the case that locations for rare

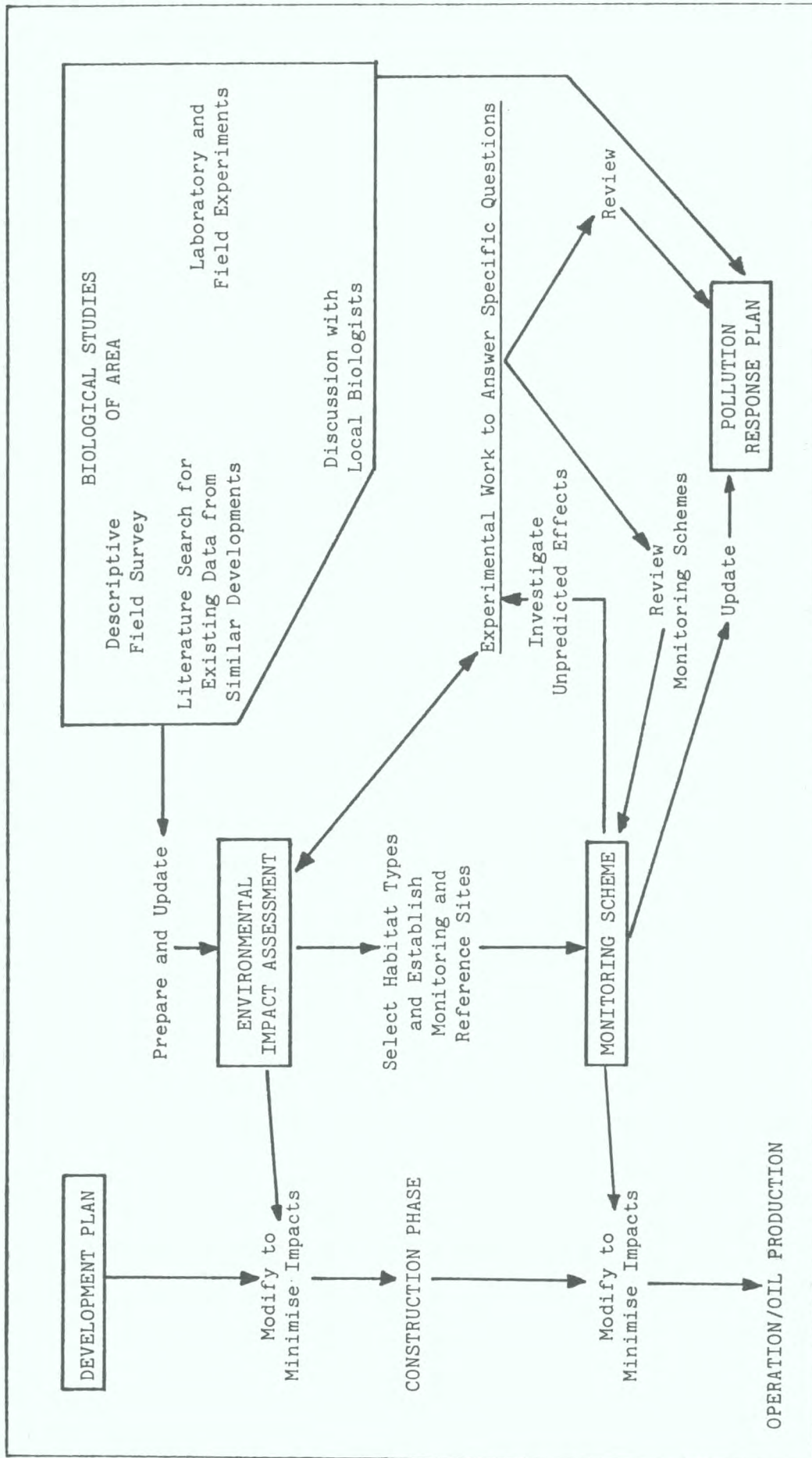

Figure III: Environmental studies in relation to a new development plan

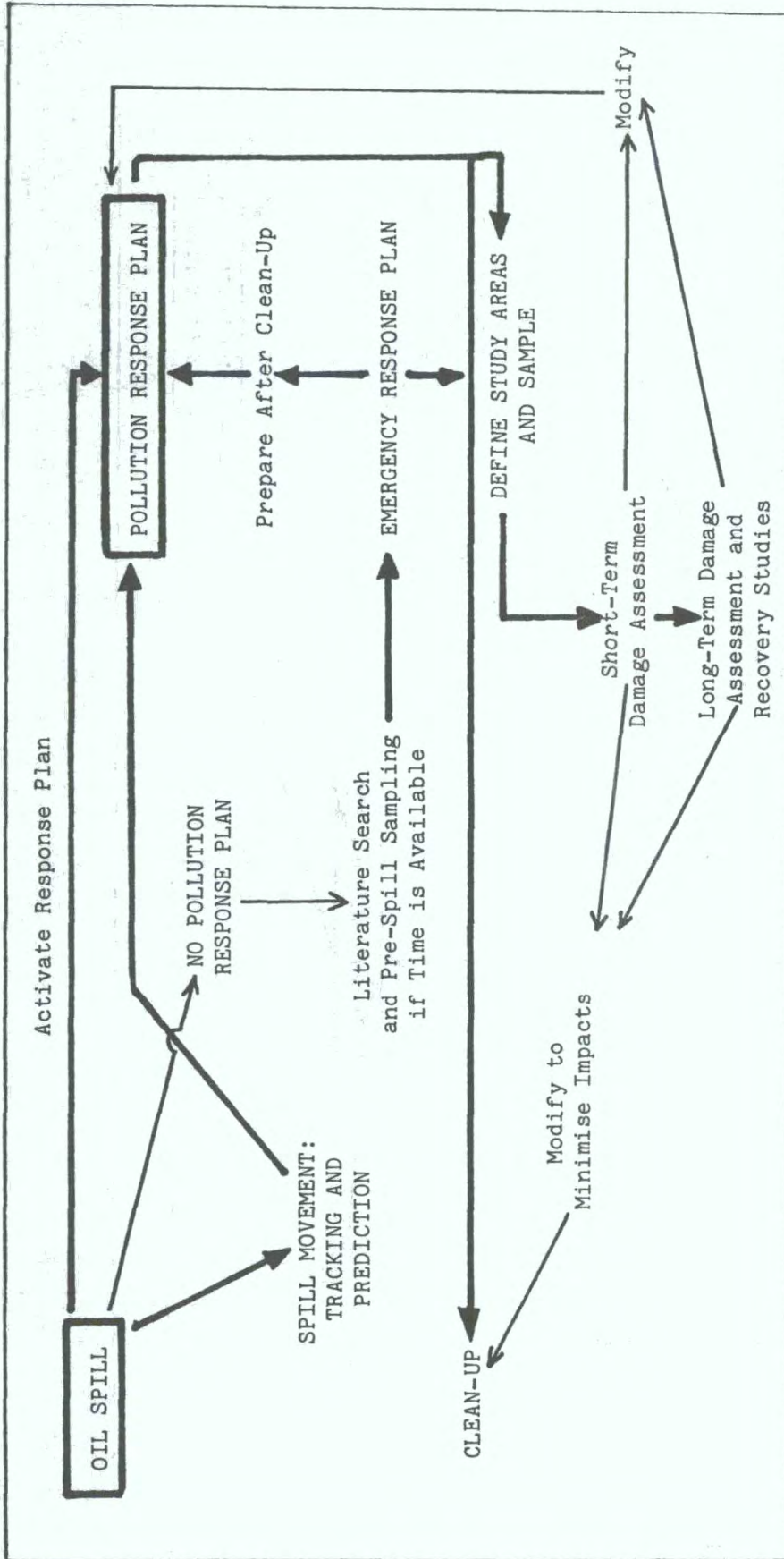

Figure III (cont'd): Environmental studies following an oil spill

or endangered species cannot be deduced from habitat descriptions or habitat maps. Secondly, little is known of the impacts of many pollutants in tropical systems, and the usefulness of laboratory or field experimental work to answer specific questions should not be overlooked. Thirdly, the value of preparation for an unforeseen event becomes clear. Once an accident has happened (e.g. a large oil spill), there is little time to set up the carefully thought-out response plans necessary to cope with clean-up and minimize biological damage. These must be prepared in advance, and should be constantly reviewed in the light of new information gained during field survey, from literature searches and local knowledge, and from experimental work. In terms of being prepared for spills it is never possible to survey whole coastal areas in advance because spills are unpredictable in all respects. It is, however, possible and useful to investigate spill effects experimentally by establishing field plots in representatives of the main community types and oiling them. Data from such experiments are valuable in predicting spill impacts and form a useful complement to descriptive habitat mapping exercises. Quoting from Baker again:

"...Oil spill impact assessment in previously unsurveyed areas presents considerable problems in selection of reference or 'control' sites and interpretation of data. For some types of investigation, field experiments provide an alternative approach which is particularly useful in the tropics as choice of experimental sites for convenience can eliminate the transport and accommodation problems of surveys in remote areas. The experimental applications of oils and dispersants are feasible in any tropical country and provide an opportunity for properly controlled, quantitative biological work of academic, applied and educational value".

Two very brief examples of current work programmes may illustrate the interactions which can take place between industry, Governments and biologists and possible types of responses. The first, a pre-development study in the Red Sea, illustrates one way in which the first part of the flow chart may function in practice, whilst the second, a response to a wellhead blow-out in Nigeria, illustrates a post-oilspill response.

Red Sea. In response to an oil company request for recommendations for environmental studies in conjunction with a new offshore oilfield and onshore marine terminal development in the Northern Red Sea, a preliminary site visit was made. During this visit it became clear that the main concerns were 1) that the area was already lightly oil-polluted from existing oil activities and this and any existing impacts needed to be defined, 2) that an extensive coral reef and shallow lagoon system was present at the site, and 3) that a long-term biological monitoring requirement was intended. Also, during the visit, details of the development in terms of installation type, locating pipeline outlets, possible discharges, etc. were provided to aid survey planning, and a very simple habitat description was prepared. The philosophy behind the selected biological studies was as follows.

Although potentially a vast number of samples would be required to describe a nearshore marine environment comprehensively, the sampling programme was restricted to those communities or ecosystems which were most likely to be sensitive to disturbance and pollution, or have proved useful in other areas for the assessment of the impact of platforms and oil terminals. These were primarily the sublittoral marine benthic communities (i.e. organisms of the coral reefs, seabed sediments, underwater rock reefs and the communities of the shore zone).

Field sampling was designed to allow as a minimum the detection and delineation of relatively gross environmental changes related to the development, taking into

account natural background environmental variation. At selected sites, quantitative sampling was employed to allow the detection of more subtle environmental changes and to correlate such changes with industrial activity. At these selected sites it was cost-effective to oversample in the field, subsequently analysing only a sufficient number of samples to achieve the required sensitivity for detecting biological change. This approach ensured that adequate samples were available for analysis, but that costly laboratory analyses were kept to a minimum.

The sampling programme was so designed that expansion or reduction in the scope of work was possible to suit either changing monitoring requirements or to allow adjustment to cater for any observed impacts.

Of particular importance was the need for the environmental surveys to provide data of use in decision-making processes within the oil companies, and in particular in planning of optimum location of effluent discharge sites, the preparation of monitoring programmes and the preparation of oil-spill contingency plans. These requirements were taken into account in the field and laboratory programme design.

The objectives of the studies were defined as follows:

1. To describe by field survey the main biological communities and habitat types for the oilfield area and the adjacent shorelines;
2. To establish and sample from carefully designed quantitative biological sampling points around the location of oil production platforms and the marine terminals, as the first stage of a long-term monitoring programme;
3. To sample at the monitoring sites and others as necessary for existing levels of pollution, and particularly for hydrocarbons in order to distinguish their mineral or biogenic origins.

The work was carried out in the following broad categories:

1. A desk study of scientific literature and biological collections relevant to the area, together with discussion with those people who had specialist knowledge of the area and its environmental problems;
2. A field survey of the shores and offshore environment of the area, concentrating on systematic survey of
  - i) the shore communities,
  - ii) the fringing coral reef communities,
  - iii) the communities of the shallow seabed (water depth less than 20 metres),
  - iv) the seabed communities of deeper waters,
  - v) the seabed sediments to assess their existing contamination by pollutants, particularly oil, and in addition,
  - vi) a descriptive survey of fisheries, water column organisms and marine birds.

Quantitative samples and those for pollution level measurements were preserved and stored as appropriate and returned to the laboratory in the UK for detailed analysis.

3. The laboratory analysis of quantitative samples, both biological and chemical;
4. The analysis and interpretation of the survey findings. This would include a full environmental description, the identification of areas or species which might be particularly vulnerable to the influence of the developments, and a series of recommendations related to additional work which might be necessary. The report would include as much information as possible relevant to the preparation of oil-spill contingency plans, the detailed design of future monitoring programmes and the location of effluent discharge points to minimize their biological effects.

The type of sampling, observation and recording techniques varied with conditions and particularly with substratum type at each site. Patterns of sampling were suggested in advance but were modified in the field in the light of existing conditions. The range of sampling methods employed included scuba and snorkel diving, dredging, trawling, grabbing and coring from a survey vessel, and the use of photography, both onshore and underwater as appropriate.

The first findings of the survey work have been passed back to the company as a series of recommendations to minimize biological impacts. These include, for example, the use of existing natural breaks on coral reefs for pipeline and jetty routes rather than construction of new ones, and the culverting of solid jetties to maintain current flows in coastal lagoons.

Post-wellhead blow-out studies in Nigeria. This example is taken directly from Baker:

"The Funiwa 5 offshore well went out of control on 17 January 1980, and oil continued to escape until 1 February when the well blocked up naturally. The main movement of oil slicks was inland to the Niger delta, primarily between the Fishtown and Sangana estuaries, and in the mangrove swamps behind the outer coastal sand ridges.

"Following preliminary ecological surveys, a detailed study programme has been agreed and is being jointly supported by the Federal Ministry of Housing and Environment, the Nigerian National Petroleum Corporation, and Texas Overseas (Nigeria) Petroleum Company. The programme is a co-operative one, involving biologists and chemists mainly from Nigeria but also from the UK. The work includes investigation of mangrove recovery rates at marked sites, a seabed survey, and field experiments to study oil and dispersant effects in mangroves..."

At the present time much of the expertise related to biological studies in the context of oilfield activities lies in the western world. There is an understandable and justifiable desire on the part of tropical oil-producing countries to involve local scientists wherever possible when it comes to oil-related work, and oil companies used to hiring whom they want may find this frustrating. Looked at in a constructive way, it is possible to use expatriate experience to complement local scientists' first-hand knowledge of their local ecosystems. This approach must surely encourage harmonious industry/Government/biologist relations to the long-term benefit of all. The need for pre-planning in the context of all oilfield development cannot be overstressed, particularly in terms of responses to major disasters, and involves extensive dialogue between all concerned.



At the moment almost all long-term studies in offshore fields are conducted on behalf of and financed by oil companies in order to meet a quite specific aim, namely to determine whether relatively large-scale biological changes are being caused by their operations, and how the situation changes with time.

Most of the above-noted studies have concentrated on macrobenthos, and although it is obviously unsatisfactory that the effects of offshore pollution on large sections of the marine flora and fauna remain unknown, the present omission of these sectors can be explained by the difficulties associated with sampling them, or lack of detailed knowledge of their natural variation and function in combination with the relatively simple aims of existing studies. Continued research is vital if we are to improve our understanding of the effects of pollution in the environment. In addition to the research needs for pollution-related studies, the underlying need for research into ecosystem function, natural variation and taxonomy must be fulfilled, for such information is of immense value in accurate measurement and interpretation of biological change and the attribution of cause to effect.

#### ACKNOWLEDGEMENTS

I would like to thank Dr. Jenifer Baker and Mr. J.P. Hartley for their helpful criticism of the manuscript during preparation, and for Dr. Baker's permission to quote sections of a paper in press. In addition, I am particularly grateful to Lucille Evans of the Oil Pollution Research Unit for her secretarial assistance.

REFERENCES

- ADDY, J.M., LEVELL, D. and HARTLEY, J.P. (1978) Biological monitoring of sediments in the Ekofisk Oil Field. In Proc. Conference on Assessment of Ecological Impact of Oil Spills. Amer. Inst. Biol. Sciences: pp. 514-539.
- ATLAS, R.M., HOROWITZ, A. and BUSDOOSH, M. (1978) Prudhoe crude oil in arctic marine ice, water and sediment ecosystems: degradation and inter-actions with microbial and benthic communities. J. Fish. Res. Board Can. 35: 585-590.
- BAKER, J.M. (1978) Marine ecology and oil pollution. J. Water Pollut. Control Fed.: 442-449.
- BAKER, J.M. (1979) The Environmental Impact of Refinery Effluents. CONCAWE Report 5/79: part III.
- BAKER, J.M. SURYOWINOTO, Ir. M., BROOKS, P. and ROWLAND, S. (1980) Tropical marine ecosystems and the oil industry with a description of a post-oil spill survey in Indonesian mangroves. In Petroleum and the Marine Environment: Conference Proc., Petromar 80, pp. 617-643 Graham and Trotman.
- BAKER, J.M. (in press) The investigation of oil industry influence on tropical marine ecosystems. Mar. Pollut. Bull.
- BOURNE, W.R.P. (1977) Seabirds and oil pollution. In Marine Pollution. (ed. R. Johnston) pp.403-502 London, Academic Press.
- BOURNE, W.R.P. (1979) Mexican offshore blow-out rivals Ekofisk. Mar. Pollut. Bull. 10(8): 215-216.
- BUCHANAN, J.B., SHEADER, M. and KINGSTON, P. (1979) Sources of variability in the benthic macrofauna of the south Northumberland coast. J. Mar. Biol. Ass. U.K. 58: 191-210.
- BUCKLEY, J. and HUMPHREY, B. (1979) Fate of dispersed oil in the environment: a boomed spill. Spill Technology Newsletter. Jan.-Feb. 1979: pp. 17-23.
- CHAPMAN, V.J., ed. (1977) Wet Coastal Ecosystems - Ecosystems of the World (I). Amsterdam, Elsevier: 423 pp.
- CLARK, Jr., R.C. and BROWN, D.W. (1977) Petroleum: properties and analyses in biotic and abiotic systems. In Effects of petroleum on Arctic and Sub-arctic Marine Environments and Organisms. Vol. 1 (ed. D.C. Malins) pp. 1-90 New York, Academic Press.
- CLARK, Jr. R.C. and MacLEOD, Jr., W.P. (1977) Inputs, transport mechanisms and observed concentrations of petroleum in the marine environment. Ibid. 91-224.
- CORMACK, D. and NICHOLS, J.A. (1977) The concentrations of oil in sea water resulting from naturally and chemically dispersed oil slicks. EPA. API. USCG World Oil Spill Conf. 1977: pp. 381-385.
- CRAMP, S., BOURNE, W.R.P. and SAUNDERS, D. (1974) The Seabirds of Britain and Ireland. London, Collins.

- CRAPP, G. (1971) Laboratory experiments with emulsifiers. In The Ecological Effects of Oil Pollution on Littoral Communities (ed. E.B. Cowell) pp. 129-149, London, Institute of Petroleum.
- CROXALL, J.P. (1975) The effect of oil on nature conservation, especially birds. In Petroleum and the Continental Shelf of North-West Europe (ed. H.A. Cole) Vol.II: Environmental Protection. pp. 93-104. London, Applied Science Pub.
- DICKS, B. (1973) Some effects of Kuwait crude oil on the limpet (Patella vulgata). J. Environ. Pollut. 5: 219-229.
- DICKS, B. (1980) Some environmental aspects of offshore oil pollution. Conf. proceedings, 'Oceanology International 80', Brighton, UK, 1980.
- DICKS, B. and BAKER, J.M. (1979) The biological effects of oil spills on the sea shore. In The Protection of the Coast of Wales from Pollution from Ship and Terminal Sources. pp. 1-10. London, Nautical Institute.
- FRASER, J.H. (1971) Zooplankton of the North Sea. In North Sea Science (ed. E. Goldberg) pp. 267-292. Cambridge, Mass. MIT Press.
- FREEMAN, J.H. (1977) The marine fouling of fixed offshore installations. Dept. of Energy Offshore Technology Paper 1.
- GLEMAREC, M. (1973) The benthic communities of the European North Atlantic continental shelf. Oceanogr. Mar. Biol. Ann. Rev. 11: 263-289.
- GRAHL-NIELSEN, O. (1973) The Ekofisk Bravo blow-out: Petroleum hydrocarbons in the sea. In Conf. on the Assessment of Ecological Impacts of Oil Spills. Amer. Inst. Biol. Sci.: pp. 476-487.
- GROSSLING, B.F. (1976) An estimate of the amounts of oil entering the oceans. In Conf. proceedings, Sources, Effects and Sinks of Hydrocarbons in the Aquatic Environment. Amer. Inst. Biol. Sci.: pp. 6-36.
- GULF UNIVERSITIES RESEARCH CONSORTIUM (1974) The offshore ecology investigation. Report No. 138, GURC, Galveston, Texas.
- HARDY, A.C. (1956) The world of plankton. In The Open Sea: Its Natural History. New Naturalist Series, London, Collins: 336 pp.
- HARTLEY, J.P. (1979) Biological monitoring of the sea bed in the Forties oilfield. In Ecological Damage Assessment Conference proceedings. Soc. Petroleum Industry Biologists, Nov. 1979: pp. 215-256.
- HUGHES, D.E. (1976) Bacterial degradation of crude oil. In The Control of Oil Pollution. (ed. J. Wardley-Smith) pp. 39-46. U.K., Graham and Trotman.
- HYLAND, J.L. and SCHNEIDER, E.D. (1976) Petroleum hydrocarbons and their effects on marine organisms, populations, communities and ecosystems. In Sources, Effects and Sinks of Hydrocarbons in the Aquatic Environment. Amer. Inst. Biol. Sci.: pp. 463-506.
- JOHNSON, J.H., BROOKS, P.W., ALDRIDGE, A.K. and ROWLANDS, S.J. (1973) Presence and sources of oil in the sediment and benthic community surrounding the Ekofisk field after the blow-out at Bravo. In Conf. on Assessment of the Ecological Impact of Oil Spills. Amer. Inst. Biol. Sci.: pp. 488-513.

- JONES, N. (1950) Marine bottom communities. Ext. Biol. Rev. 25: 283-313.
- KOONS, C.B., MCAULIFFE, C.D. and WEISS, F.T. (1975) Environmental aspects of produced waters from oil and gas extraction operations in offshore and coastal waters. Report to: SHEEN Technical Sub-committee, Offshore Operators Committee, New Orleans LA.
- KOONS, C.B. and MONAGHAN, P.H. (1976) Input of hydrocarbons from seeps and recent biogenic sources. In Sources, Effects and Sinks of Hydrocarbons in the Aquatic Environment. Amer. Inst. Biol. Sci.: pp. 84-107.
- KUHNHOLD, W.W. (1972) The influence of crude oils on fish fry. In Marine Pollution and Sea Life (ed. M. Ruivo) pp.315-317. London, Fishing News (Books).
- KUHNHOLD, W.W., EVERICH, D., STEGMAN, J.J., LAKE, J. and WOLKE, R.E. (1979) Effects of low levels of hydrocarbons on embryonic, larval and adult winter flounder (*Pseudopleuronectes americanus*). In Conf. on Assessment of Ecological Impact of Oil Spills. Amer. Inst. Biol. Sci.: pp. 677-711.
- LAKE BUENA VISTA, Florida (1980) Research on Environmental Fate and Effects of Drilling Fluids and Cuttings. Vols. I and II. Symposium Proceedings.
- LAW, R.J. (1973) Petroleum hydrocarbon analyses conducted following the wreck of the supertanker Amoco Cadiz. Mar. Pollut. Bull. 9(11): 293-296.
- LOYA, Y. and RINKEVICH, B. (1980) Effects of oil pollution on coral reef communities. Marine Ecology - Prog. Series, Vol. 3: pp. 117-180.
- MAYO, D.W., PAGE, D.S., COOLEY, J., SORENSON, E., BRADLEY, F., GILFILLAN, E.S. and HANSON, S.A. (1973) Weathering characteristics of petroleum hydrocarbons deposited in fine clay sediments. Searsport, Maine. J. Fish. Res. Board Can. 35: 554-562.
- MORSON, B. (1979, in press) Society for Petroleum Industry Biologists, Conf. on Ecological Damage Assessment.
- ODUM, E.P. (1971) Fundamentals of Ecology. Philadelphia-London-Toronto, W.B. Saunders.
- OSIR (1979) Oil Spill Intelligence Report: US Senate Discusses Ixtoc 1 Spill. OSIR, 2 (50): 1-2.
- PARKER, R.H. (1975) The Study of Benthic Communities: A Model and a Review. Elsevier, Amsterdam: 279 pp.
- RAYMONT, J.E.G. (1963). Plankton and Productivity in the Oceans. Oxford, Pergamon Press: 660 pp.
- REES, E.I.S., NICHOLAIDOU, A. and LASKARIDOU, P. (1977) The effects of storms on the dynamics of shallow water benthic associations. In Biology of Benthic Organisms (10th European Symposium on Marine Biology) eds. B.F. Keegan, P. O'Ceidigh and P.J.S. Boaden. Oxford, Pergamon Press.
- R.S.P.D. (1979) Marine Oil Pollution and Birds. R.S.P.D. Report, Oct. 1979.
- RAY, J.P. (1980) The effects of petroleum hydrocarbons on corals. In Petroleum and the Marine Environment. Conf. Proc. 'Petromar 80': pp. 645-666. Graham and Trotman.

- READ, A.D. and BLACKMAN, R.A.A. (1980) Oily water discharges from offshore North Sea installations: A perspective. Mar. Pollut. Bull. 2: 44-47.
- SANBORN, H.R. (1977) Effects of petroleum on ecosystems. In Effects of Petroleum on Arctic and Subarctic Marine Environments and Organisms (ed. D.C. Malins) pp. 337-359. New York, Academic Press.
- SANDERS, H.L. (1968) Marine benthic diversity - a comparative study. Am. Natur. 102 (925): 243-282.
- SHARP, J.M., APPAN, S.G., BENDER, M.E., LINTON, T.L., REISH, D.J. and WARD, C.H. (1979) Natural variability of biological community structure as a quantitative basis for ecological impact assessment. In Ecological Damage Assessment Conference Proc. Society for Petroleum Industry Biologists: pp. 257-284.
- SHELTON, R.G.J. and NICHOLLS, J. (1974) GESAMP Working Group on the scientific aspects of pollution arising from exploration and exploitation of the seabed: ANNEX VI - Petroleum (including natural gas). GESAMP, 1974.
- STRAUGHAN, D. (1977) The sublethal effects of natural chronic exposure to petroleum on marine invertebrates. EPA.API.USCG World Oil Spill Conference Proc. New-Orleans: pp. 563-569.
- THOMPSON, J.H. and BRIGHT, T.J. (1977) Effects of drill mud on sediment clearing rates of certain hermatypic corals. Ibid. 495-499.
- THORSON, G. (1966) Some factors influencing the recruitment and establishment of marine benthic communities. Netherlands J. Sea. Res. 3(2): 267-293.
- THORSON, G. (1971) Life in the Sea. New York, World University Library: 256 pp.
- WARDLEY-SMITH, J. (1976) The Control of Oil Pollution. U.K., Graham and Trotman: 251 pp.
- WOLFSON, A., VAN BLARICOM, G., DAVIS, N., and LEWBEL, G.S. (1979) The marine life of an offshore oil platform. Mar. Ecol. Prog. Serv. 1: 81-89.
- VARANASI, U. and MALINS, D.C. (1977) Metabolism of petroleum hydrocarbons: Accumulation and biotransformation in marine organisms. In Effects of Petroleum on Arctic and Subarctic Marine Environments and Organisms. (ed. D.C. Malins) pp. 175-270) New York, Academic Press.

TRAINING IN OIL WELL BLOW-OUT PREVENTION  
AND THE ROLE OF SIMULATORS

by  
E. Hull

Petroleum Industry Training Board,  
Aylesbury, Bucks, U.K.

ABSTRACT

The paper contains a brief description of the causes of a blow-out and the equipment normally in use to prevent them. The problems drillers have to face in the early detection of impending blow-outs are discussed and the need for training is established. Basic well control training is described with general reference to simulators and the part that they can play in representing a variety of dangerous and difficult situations under classroom conditions. Brief reference is made to unsafe conditions other than those encountered while drilling, for example, during remedial work known as "workover" and emphasis is placed on the need for management motivation and environment.

## BLOW-OUT

To all of us, whether we are directly in the business of producing oil, or whether we are associated more indirectly, it is an emotive word. At best it implies the loss of a valuable and increasingly rare asset - fossilized energy. At worst it can result in loss of life. Between these two we have the probable risk of serious environmental pollution and a cost of millions - in whatever currency.

What is a Blow-out? In the early days of drilling for oil, a gusher - when oil flowed out of control from a well - was a sign of success. After the well was capped and the flow was directed into pipes on the surface to a depressurizing system, it meant a far greater than average production rate. In those early days wells were shallow in depth and the majority had to be equipped with pumps to bring the oil to the surface. Drilling was carried out by a method called Cable Tooling which involved the raising and dropping of a heavy chisel-type bit. There was nothing to stop the influx of fluid or gas into the well.

The development of modern rotary drilling has enabled us to drill deeper, faster and more safely, since a steel pipe connects the bit to the surface and a fluid is pumped down inside the pipe and back up the annulus between the pipe and the sides of the hole. It was soon realized that this fluid exerted a hydrostatic pressure on the bottom of the hole and that, by adding a weighting agent, higher pressure than that controllable by a column of water could be contained in the well.

But we still continue to experience blow-outs. Today they are not a sign of success, but of failure - failure to do the job properly.

A blow-out occurs, quite simply, when the hydrostatic head of the fluid in the well (usually called "the mud") becomes less than the formation pressure, and the driller fails to recognize the consequent indications.

It may well not be the driller's fault that these indications are present, (a hazard is always present on exploratory wells or wildcats when pressure may not be known), but he does have a number of resources available to help him overcome the situation.

Firstly, modern drilling rigs are equipped with blow-out preventers which are fitted to the top of the casing cemented in the well. These blow-out preventers, or BOP stacks as they are commonly known, consist of a series of ram-type devices which can be closed, by hydraulic pressure, either around the drill pipe or across an open hole. On the top of the ram-type preventers is a "bag"-type or annular preventer, which, when closed, permits the movement of the drill pipe through it, or will effect total closure on an open hole.

Secondly the driller has in the hole a column of drilling mud. This may not, at any one time, have the proper characteristics to cope with an influx of formation fluid or gas, but provides him with the basic tool with which he can regain control.

Thirdly, the driller has under his control a complex system of valves which enable mud, under controlled pressure from the well, to be passed through the degasser and other processes to the suction tanks for subsequent re-circulation. This valve system is known as the Choke Manifold.

Using a combination of the BOPs, Choke Manifold and pumps the driller can safely pump down the drill pipe to the well a mud of the correct weight to control the influx and thus prevent a blow-out.

The procedure just described would appear to be a relatively simple matter. In other words (a) recognize there is a problem, in that there is a "kick"; (b) close in the well with the BOPs and (c) add weighting material to the mud and pump it to the well. It is a simple matter if - and the if must be emphasized - the driller has received proper training.

Drilling is not an easy job. It entails using a complex and expensive piece of machinery continuously to its best advantage, working with a team of men, who, frequently under difficult conditions, are handling heavy and awkward equipment, to open up a potentially dangerous situation perhaps two or three miles below the man in control. As one driller once said when asked how he was getting on with recovering some lost drill pipe in a 12,500 foot well: "It's a good job but I'd like to be closer to my work".

With offshore rig hire day rates in excess of 35,000 in some areas, the owner of a well wants it drilled as fast as possible - but he wants it drilled properly and safely. The driller is, or should be, aware of this, but there must always be a tendency to emphasize speed of operations. Time is money and many drillers regard time not spent making a new hole as time wasted. This, under some circumstances, is laudable, but occasionally it can be a case of 'more haste less speed'.

I have attempted to demonstrate that the driller has much on his mind. Uppermost must be an awareness of the potential disaster if he fails to recognize that his well is in a "kick" situation. Having recognized this, he must have the proper background to be able to deal with the situation competently.

The need for training of drillers and supervisory personnel in kick control has been demonstrated. How seriously is such training taken and how is it carried out?

The answer is that a majority of drilling companies take it very seriously indeed and adopt a thoroughly responsible attitude in that they will frequently expect their employees to exceed the requirements, where these exist, of the regulatory authorities of those countries in which they are operating. Naturally there are exceptions, but fortunatley these are by no means as numerous as they were even a few years ago.

Governments of countries in which oil or gas has been found, or is likely to be discovered, either on or offshore, are viewing with increasing concern the disastrous results which can follow a blow-out, and many have taken or are taking action to ensure that drilling crews are competent.

Such regulatory action varies from country to country, from requiring specific courses of training in Government-approved schools where a certificate is issued on successful completion of a test, to merely requiring that drillers and supervisory personnel can demonstrate to a pre-determined standard an adequate knowledge of kick control.

Training provided varies in detail, since there are different methods of kick control and different approaches to be adopted in carrying out these methods. The aim, however, of all training is, as we have seen, to enable the driller to recognize the kick and to take such action as is necessary to obtain control.

The first element - recognition of a kick - requires only that the driller and his crew, as well as the rig site geologist or mud logger, are taught to remember that six factors only are indicative.

Good training will require the explanation of why these factors are danger



signs, because men will always remember and react to something they understand more readily than something learned parrot-fashion.

The second element - making the well temporarily safe - involves shutting it in and preparing for the kill procedure by recording specific data.

The procedure for closing in a well varies slightly according to differing company policies, but one commonly accepted procedure is 1. To pick up the bit off bottom to a point where the pipe rams will not close on a tool joint. 2. Stop the pump. 3. Open the choke line. 4. Close the annular preventer. 5. Close the choke. 6. Close the pipe rams and open the annular preventer. The amount the well has flowed back is then recorded, and recordings are made of the pressures in the drill pipe and on the annulus after they have stabilized.

The above closing-in procedure is essentially mechanical and it is the normal practice of drilling companies to require that such drills, as well as routine testing of the BOP equipment, are carried out on the rig regularly, both to ensure that crews are fully aware of the sequence of operations and that the equipment is operating satisfactorily.

The teaching of the closing-in procedure is, however, an integral part of the syllabus of any school teaching pressure control.

Apart from the recognizable indications of a kick and the physical requirements for closing in the well, today's drillers, unlike their early predecessors (who, while in many cases first-class men, were often illiterate) need to be numerate.

There are certain basic principles and procedures in kick control which require the use of well established simple arithmetic formulae. A number of systems have been evolved to eliminate the need to memorize these formulae and the majority of rigs nowadays have at least pocket calculators as almost standard equipment. However, an ability to understand the arithmetic involved is still essential for the driller.

Following the closing-in phase of kick control, the drilling crew can then begin the killing operation. This can be done in a variety of ways, the three most common being known as the driller's method, the wait and weight method and the concurrent method. However, the "art" of kick control is continuously developing and a variety of other techniques are now available which may be more suitable for the particular conditions obtaining.

The three methods mentioned above are, however, the best known and it would be appropriate to summarize the differences. The driller's method is the simplest in that only three calculations are required - the weight of the kill mud required, the capacity of the drill pipe in the well, and the capacity of the annulus. In the wait and weight method additional calculations are needed since it is necessary to know the pump strokes required to fill the drill pipe and for the subsequent reduction in circulating pressure as the pipe is filled. The concurrent method has the additional complication of possibly two or more mud weights being present in the drill pipe at the same time.

So we have arrived at the nucleus of a training syllabus - but only a nucleus. We are primarily concerned with the training required for the prevention of a blow-out and we have dealt so far only with a case of a simple kick. Many volumes have, however, been written, dealing with the more complex problems that can arise.

Apart from experienced, competent and credible lecturers, training over the last twenty years or so has been enhanced by the development of simulators. Since

the pressure situation in a well at any time can be expressed in mathematical terms, it follows that variations in the pressure regime can be referred to a mini-computer. Other parameters can also be applied such as the quantity of mud pumped, the diameter of the hole, the time taken for a particular event to occur, etc.

Early models were somewhat limited in application but the principle of the more sophisticated models available today is essentially the same. Both analog and digital systems are used by different manufacturers, the preference for one or the other depending on the user's requirements. For example, a simple analog simulator may be quite adequate to introduce a driller to kick control, but a senior driller, company representative or drilling supervisor may require a larger, more sophisticated instrument with an input of a wider range of variable parameters.

These simulators have a variety of controls, operated by the trainee, comparable to those on the derrick floor. In some models these controls are in miniature, in some full-scale. The trainee can read off a variety of operational data and take appropriate action as necessary. The control panel is connected to a programming panel operated by the instructor who can either pre-programme a particular situation for the trainee to react to, or, in some models, inject additional complications at random.

Modern simulators are now designed to reproduce not only kick control situations but also a full range of parameters comparable with those a driller may encounter. These larger models may, therefore, be used for training drillers to drill more efficiently as well as instructing them in the more limited, but nevertheless vitally important, operation of kick control.

The question can be asked - is it not more satisfactory to train a drilling crew in blow-out prevention on a real well drilled specifically for training purposes? This has been done, with high-pressure inert gas being injected at the bottom of the hole. No doubt there is still a place for this mode of training under certain circumstances, but there are disadvantages both of cost and the time taken to perform certain phases of the operation. The modern simulators, once the trainee has initiated certain actions, can be speeded up to complete the particular phase in up to one tenth of the time it would actually take.

We have, so far, discussed training for blow-out prevention with particular reference to drilling new wells. Mention has been made of the increased hazard of drilling exploratory wells when formation pressures cannot be accurately predicted. Drilling of appraisal and development wells, once a new field has been discovered, should present a reduced hazard since pressure data are available, and drilling programmes can be designed to take into account known pressures.

Nevertheless, the hazard is always present and training of crews involved in development drilling is no less important.

There is yet another phase of operations when a blow-out can occur and statistics suggest that this phase can be more important than that of drilling new wells. At some time in the life of nearly all producing wells some form of remedial work will be required. Equipment "down hole" may need to be replaced, there may be a necessity to clean out sand which has entered the well bore, perforations in the production casing may have become plugged, encroaching gas or water may have to be cemented off.

The operation to deal with all these situations, of which but a few examples have been given, is known as a Workover, and frequently requires the removal of the

Production Wellhead to gain access to the well before replacing it with the drilling BOP stack. Although the well will have been killed before starting this operation it still presents a potentially dangerous condition unless carried out by competent personnel.

Workover operations subsequently are similar in many ways to those carried out in the drilling and completion of a well for production except that the well is potentially live at all times. It is therefore particularly important that drilling crews involved in workover operations are properly trained in basic pressure control procedure and in the more specialized aspects of workovers, and that, as in all pressure control training, initial exposure is followed up by regular refresher courses.

Currently available simulators can provide assistance in training crews in workover operations in addition to drilling problems. The advantages are obvious in that, again, potentially dangerous situations can be reproduced under classroom conditions, with trainees carrying out exercises with very close facsimilies of real-life equipment.

We have discussed at some length the causes of kicks and blow-outs and we have seen the need for training and given some idea of what is involved.

However, one element is so far lacking. This is Management involvement and motivation. Training programmes must have the full support of Management to make them effective, and by Management support we mean something more than lip service.

Time has to be made available to enable men to receive training in blow-out prevention and to attend refresher courses on a regular basis.

This involves Management in organizing appropriate work schedules and, in addition, making such budgetary provision as may be appropriate. Management must also be involved in ensuring that a proper mental attitude to training is prevalent in their companies. Training should not be regarded as a paid holiday away from the rig floor, or a process through which men have to go to satisfy a regulatory authority's requirements. Properly carried out by competent instructors using the best training aids, it should not only form an essential part of an employee's career programme but will unquestionably make a major contribution towards preventing a disaster in terms of pollution, and may well save lives.

OILY WATER DISCHARGES FROM OFFSHORE OIL INSTALLATIONS, THEIR ORIGIN  
AND TREATMENT AND SOME EXAMPLES OF THEIR REGULATION

by  
A. D. Read

International Oil Industry Exploration and Production Forum,  
London, England, U.K.

ABSTRACT

Recent attention has been focused on the need to control discharges from offshore installations. The paper examines the operations and activities that give rise to such discharges and describes some of the characteristics of the various streams that can require treatment. Mention is made of the various types of equipment and operating procedures that have been or are being developed to reduce their oil content to a minimum. Estimates are given, based on industry-wide surveys of the performance levels that can be expected from well run equipment for the removal of particulate oil. Such surveys have provided the basis for the controls that have been introduced by the US and UK authorities. These controls are discussed, as are those developed by agreement between the various States of N-W Europe, within the framework of the Paris Convention. An example is given of the concentration in the sea near an installation anticipated to result from such controlled discharges.

## PLATFORM OPERATIONS GIVING RISE TO DISCHARGES

Crude oil, when produced at the well-head, is generally accompanied by gas (often dissolved) and produced water (often formation water which naturally co-existed with the oil in the reservoir). At the production platform the gas and water are separated from the oil in successive stages (see typical flow scheme in figure I). Dehydration of the wet gas provides dry gas, which can be handled in various ways dependent on its final destination (gas-tanker, pipeline, re-injection).

Separation of the co-produced water from the crude oil (dehydration) provides the main stream of 'dry' oil which can be piped to large tanks at the platform base, or into a separate storage facility for retention, prior to being transported ashore. The long residence time in these storage tanks permits the separation of further water from the oil by gravity separation. On most installations there is no such buffer storage and the oil is relayed straight from the dehydration stage by tanker or pipeline to shore.

Although the operations described above usually generate the principal flows of oily water from installations, others can originate from drainage from the production or drilling areas, from drilling mud and cuttings processing equipment and from tankers (should non-segregated or permanent ballast tankers not be used for relaying the oil to shore). Since the different streams vary in nature, volume and their amenability to treatment, it is proposed to discuss each in turn.

### Gas dehydration

This is usually performed using a dessicant (often ethylene glycol). Thereafter the water is boiled off the glycol and vented to atmosphere. In cases where water is removed from the gas by cooling, the water obtained is usually fed with the produced-water stream for further treatment. Gas processing usually generates only small volumes of oily water, this water being normally contaminated by light rather than persistent oils.

### Produced water

This is the water that is co-produced with the oil. It largely originates from the reservoir and has co-existed with the oil in the reservoir for millions of years. During its passage from the reservoir it is subjected to high shear conditions which can result in the formation of emulsions that are difficult to break. Its prolonged contact with oil and gas under pressure also frequently results in there being appreciable quantities of hydrocarbons and other organic compounds in solution. The volumes of production water to be treated are usually small during the initial life of an oilfield, but increase progressively as the field is depleted and water invades the rock formation of the natural reservoir.

In cases where water injection has been applied to maintain reservoir pressure, such injection water may also be subsequently co-produced with the oil. The oil content of produced water after primary separation is usually in the range 100-1,000 ppm. These waters are thus rarely grossly contaminated with oil, but what there is can be difficult to remove.

### Displacement water

This water is sea-water contaminated with produced water and oil which has accumulated during the loading cycle of a storage facility. Such storage tanks hold

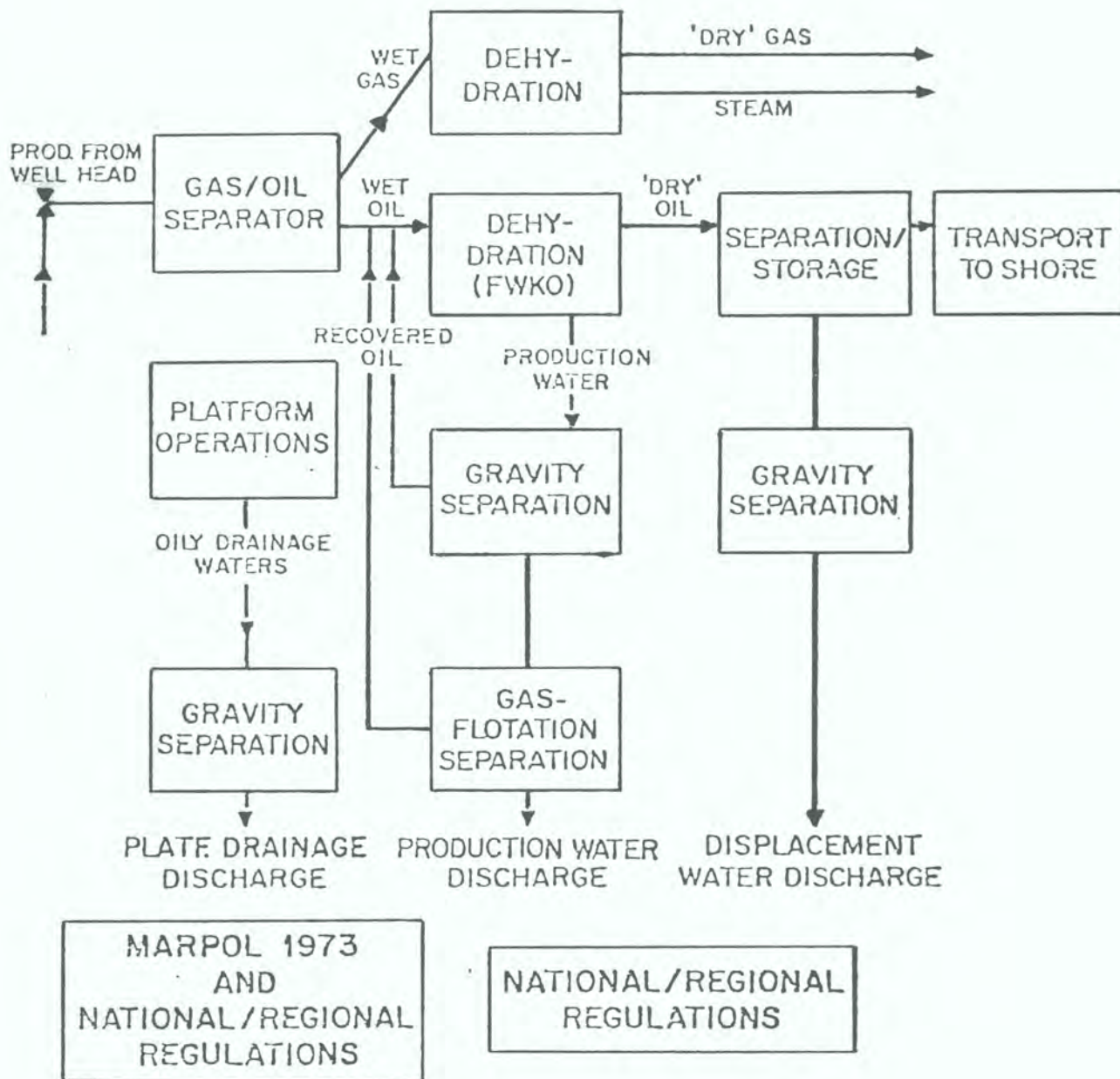

Figure 1: Offshore platform discharges

produced oil on top of sea-water. The contact between the oil and water is transient and so the displacement water is usually only slightly contaminated with oil. However, wax and particulate stabilized emulsions can accumulate at oil/water interface in the cells and on occasion appear with the displacement water. There is also the possibility that the cells could be over-filled and neat oil could flow into the displacement water treatment system. Level control in the storage cells is probably much more important than effluent treatment in minimizing oil releases from these storage systems.

#### Drainage water

Modern oil production platforms invariably have a number of separate drainage systems. Three of the main ones are:

- (i) high-pressure closed drains
- (ii) low-pressure closed drains
- (iii) open drains.

Any collected fluids from the first two, as might be implied from their names, are pumped straight back to the separation train. The closed drains cover all parts of the platform that would normally be oily in every-day operations (fire risk considerations dictate that such areas must be enclosed). The open drains cover the other parts of the platform, which are not usually but can on occasion be contaminated by oil. The drainage water may result from run-off if sea spray, rain or cleansing water washes some oily material from equipment or decks. This platform drainage system is usually separate and different from the systems that treat produced or displacement water because of the inherent incompatibility in volume flow, chemical composition and corrosivity between the two streams.

Platform drainings are by their nature fluctuating flows both in terms of volume and oil content. The facility for treating such flows needs to be capable of handling large flows, fairly tolerant to the presence of detergents (when these are used to wash down decks) yet capable of retaining the occasional large slugs of oil which may be washed down. The requirements for an effective drainage system are very different to those for production water treatment, where the stream to be treated is usually fairly consistent in character and flow rate, and is free from extraneous surfactants. It is usual for these and other reasons for there to be separate treatment facilities for the open-drain fluids.

#### Drilling mud and drill cuttings

These muds are used in the drilling of deep wells to lubricate the bit, transport the cuttings to the surface and stabilize the sides of the hole. The quality of these muds deteriorates in use and from time to time they have to be discarded. Much research has been done on the environmental impact of such discharges and it is not proposed to review those findings in this paper, suffice to say that at most locations where studies have been made the impacts have been found to be highly localized.

However, a treatise on oily water discharges from offshore oil activities would not be complete without mention of those associated with mud and cuttings disposal. There are two main types of mud in use:

- (i) water-based muds
- (ii) invert emulsion muds where the solids are dispersed in a roughly 30:70 water in diesel emulsion.

The former are usually free of hydrocarbons but can on occasion contain up to 6 per cent by weight diesel in the mud. This is added to improve the lubrication properties of the mud. The diesel is present in such muds in a very finely dispersed state. There are no known practicable ways of removing it once it is added and, consequently, such muds are usually either discharged untreated from the platform or barged elsewhere for disposal, if the platform is in a particularly environmentally sensitive area (the control of such discharges is one aspect of controls on drilling muds and their disposal which will not be considered further here).

The disposal of the invert emulsion muds presents less intractable problems. They can either be burnt or shipped ashore for re-processing. There is no need for such muds to be discharged to the sea. However, the cuttings from wells drilled with invert emulsion muds can be contaminated by diesel to the extent of 15-20 per cent by weight. The cleaning of such cuttings presents difficulties which have only recently been looked at seriously. A typical 4,000m deep offshore well might yield 1,000 tonnes of cuttings in toto and up to 10 tonnes per hour during peak drilling rates (the treatment and disposal of such cuttings can present severe problems which have yet to be fully solved).

#### Tanker ballast

The direct discharge of non-segregated tanker ballast to the sea at platforms is effectively prohibited in most areas by the 1969 amendments to the 1954 Convention on Oil Pollution of the Sea. It is technically possible, but rarely allowed, for such ballast waters from loading tankers to be pumped to the platform for treatment and disposal. Ballast waters have in most cases been pumped into the tanker at the crude unloading terminal and may therefore vary considerably in salinity from that of sea to near fresh water. During the voyage they will take up some of the oil retained in the tanks. As this oil has weathered considerably during many weeks, most volatile components will have disappeared. Any oil in the ballast water will probably be in droplet form. The treatment of most of such waters on a platform might therefore present fewer problems than those posed by some production waters. However, in the latter stages of de-ballasting a tanker, the oil content of the water can be up to the 1 per cent level. While it is relatively easy to cope with such slugs at onshore treatment facilities, they would be difficult to treat at the inevitably compact, short residence-time, offshore facilities. It is largely for this reason that most industry procedures and government regulations do not permit discharges of ballast via offshore installations.

#### TREATMENT TECHNOLOGY FOR OIL/WATER SEPARATION

The separation of oil from water is facilitated by the one being largely immiscible with the other, and the difference in density between the two. Most components of crude oil are insoluble in water and most crudes have a lower specific gravity (i.e. they are lighter) than water. Oil in water dispersions will usually, given time, separate spontaneously into two phases. The rate of separation for an oil droplet of radius  $r$  rising through a liquid of viscosity  $\eta$  of under laminar flow conditions is governed by the following equation derived from Stokes Law:



$$\text{terminal velocity } v = \frac{2}{9} \frac{r^2 g (\delta - \epsilon)}{\eta}$$

where  $g$  = gravitational constant  
 $\delta$  = density of oil in droplet  
 $\epsilon$  = density of continuous liquid

Thus the rise rate is proportional to the difference in density between the two phases and to the square of the droplet radius. Since nothing much can be done to alter the density and/or viscosity of the two phases, the only parameters that the separation system designer or operator can exploit are droplet size, residence time and rise distance necessary to effect a separation. Coalescence and flocculation can be used to enhance effective droplet size. In order to minimize droplet breakdown it is important to select and design the valves, pumps and pipework used, so as to reduce shear intensities upstream of the separators. There is also, as will be seen below in the descriptions of the various types of separator, considerable scope in minimizing the rise distance necessary for separation.

#### Simple gravity separation

The simplest form of oily water separator is provided by tanks and sumps, fitted with weirs or other skimming devices with which oil accumulating at the top can be periodically or continuously removed. Examples of the use of this technique on offshore installations are the large-diameter caissons with outlets well below sea level. These can provide adequately long residence time for fairly coarse oil droplets to rise to the top and be removed. They are suitable for the treatment of open-drain waters since they can cope with very variable oil contents in their feed. For good operation they require a good oil/water interface detection system to initiate accumulated oil removal, a powerful pump not prone to jamming by the inevitable debris, to remove the oil, and a long enough residence time for the fluids in the sump. The latter can be achieved partly by adequate sizing, but also by limiting the types of flows reaching the sump. Since the sump will probably not remove oil droplets finer than 50-100  $\mu$  in diameter it is counter-productive to use it for streams where any residual oil (due to prior treatment or other reasons) is already well below this size.

Another example of the use of simple gravity separation on platforms is the skimmer tanks placed just upstream of the flotation or parallel plate interceptors. These serve to catch occasional slugs of oil released during process upsets further upstream. They will not remove droplets finer than about 100  $\mu$  in diameter, but they should prevent high oil loadings on the downstream flotation and/or parallel plate interceptor units, the performance of which can otherwise be affected for days afterwards.

A widely used variant of the simple tank separator is the horizontal gravity or API separator. This is widely used onshore but still occasionally offshore. The oil in water dispersion is introduced at one end of the vessel, and at the opposite end the coalesced phases are removed - the lighter oil fraction being removed from the top by a mechanical skimmer with the heavier water fraction being removed from the bottom. This is shown diagrammatically in figure II.

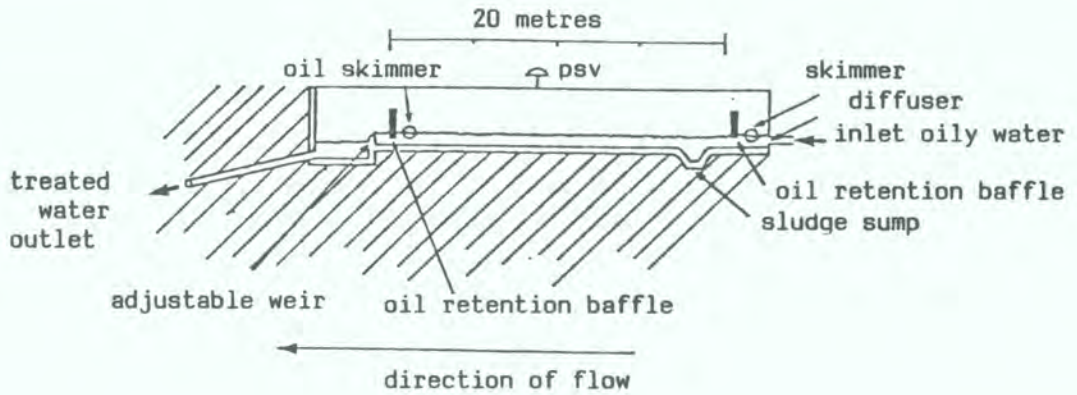

Figure II: Layout of Typical APT Separator

API separators are so designed that any oil globule with a rate of rise greater or equal to the overflow rate, which is defined as the throughput per unit effective surface area, will be removed from the system. Residence times of the order of 30 minutes in a conventional API separator result in the removal of droplets coarser than  $150 \mu$ . These systems are generally long and wide but relatively shallow. They therefore require a considerable amount of space - a commodity rarely available offshore.

#### Parallel plate interceptors

These were developed both to reduce space requirements and to improve separation efficiency. Basically the improvements have been achieved by reducing the distance through which the droplets have to rise to effect a separation and by ensuring a laminar rather than a turbulent flow regime. The use of multiple plates gives a large increase in surface area available for separation and therefore produces a compact installation. The plates in these separators are arranged parallel to each other and inclined at an angle of  $45^\circ$  to the horizontal. A representation of a cross section of one is shown in figure III.

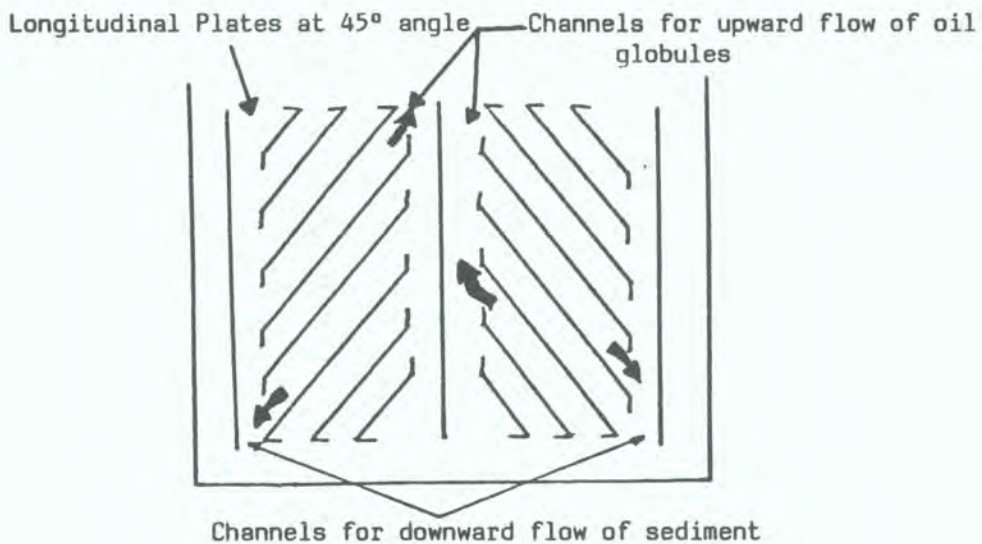

Figure III: Cross-section of a parallel plate interceptor

Rising oil globules coalesce on the under-side of the plates, slide up the plate and then rise through oil flow channels to the surface where the oil is removed with a skimmer.

A variant of the above is the corrugated plate interceptor (CPI) shown in figure IV. In these the oil droplets rise up the under-side of the corrugations and any sedimented solids fall back along the troughs in the top side to collect in a sludge compartment at the bottom. This type of unit is usually sized so as to remove all droplets coarser than  $60\ \mu$  in diameter.

A further variant specially developed for offshore use is the CJB Pressure Separator. In order to maximize oil capture at a given residence time the plate packs are mounted in a pressure vessel. The advantage of operating at elevated pressures is that it should avoid some of the droplet breakdown effects caused by shear in the pressure reduction stages. Additionally, use of cross flow configurations permits a much larger quantity of separating surface to be incorporated into a given size of vessel than is possible with the more usual type of pack and flow pattern. The design residence time is about five minutes. A simplified flow-out illustrating the use of such a separator is shown in figure V.

In gas flotation units gas bubbles are dispersed in the body of the contaminated water. As the bubbles rise through the liquid they adhere to the hydrophobic oil droplets with which they come in contact and rise to the top to form an oily froth which can be skimmed off. There are two major types of gas flotation systems:

- (i) dispersed air flotation in which air or gas bubbles are entrained in the liquid using induced flow impellers, or are pumped in by a compressor through a sparger, and
- (ii) dissolved air flotation in which gas is dissolved in the waste stream under pressure, comes out of solution when the pressure is released and forms gas bubbles, which again rise to the surface with adhering oil droplets.

The dissolved air system yields fine bubbles and is probably capable of removing finer oil droplets than is possible with the dispersed system, particularly when certain chemicals are used which form a floc blanket. However, the former normally requires a residence time of about 30 minutes for efficient separation, so the other type, the dispersed air flotation unit, which only requires a five-minute residence time, has found far wider application offshore. A diagram of a typical unit is shown in figure VI (a) and (b). These systems can be used with either air or natural gas. When they are operating well they can achieve over 90 per cent oil removal, with an influent containing in excess of 150 ppm.

However, it is usually necessary to add a few parts per million of a suitable flocculant to aggregate the oil droplets and so enhance their chance of encountering a gas bubble. Similarly, if there is any tendency for emulsions to form in the streams from particular wells, it is usually also necessary to add emulsion breakers at the well head and to modify the level of such additions when the flows from different wells are altered for any reason. Finally, good level control at the water/froth interface and regular maintenance of the froth removing paddles is required to ensure efficient oily froth removal, and thus to maintain good separation conditions.

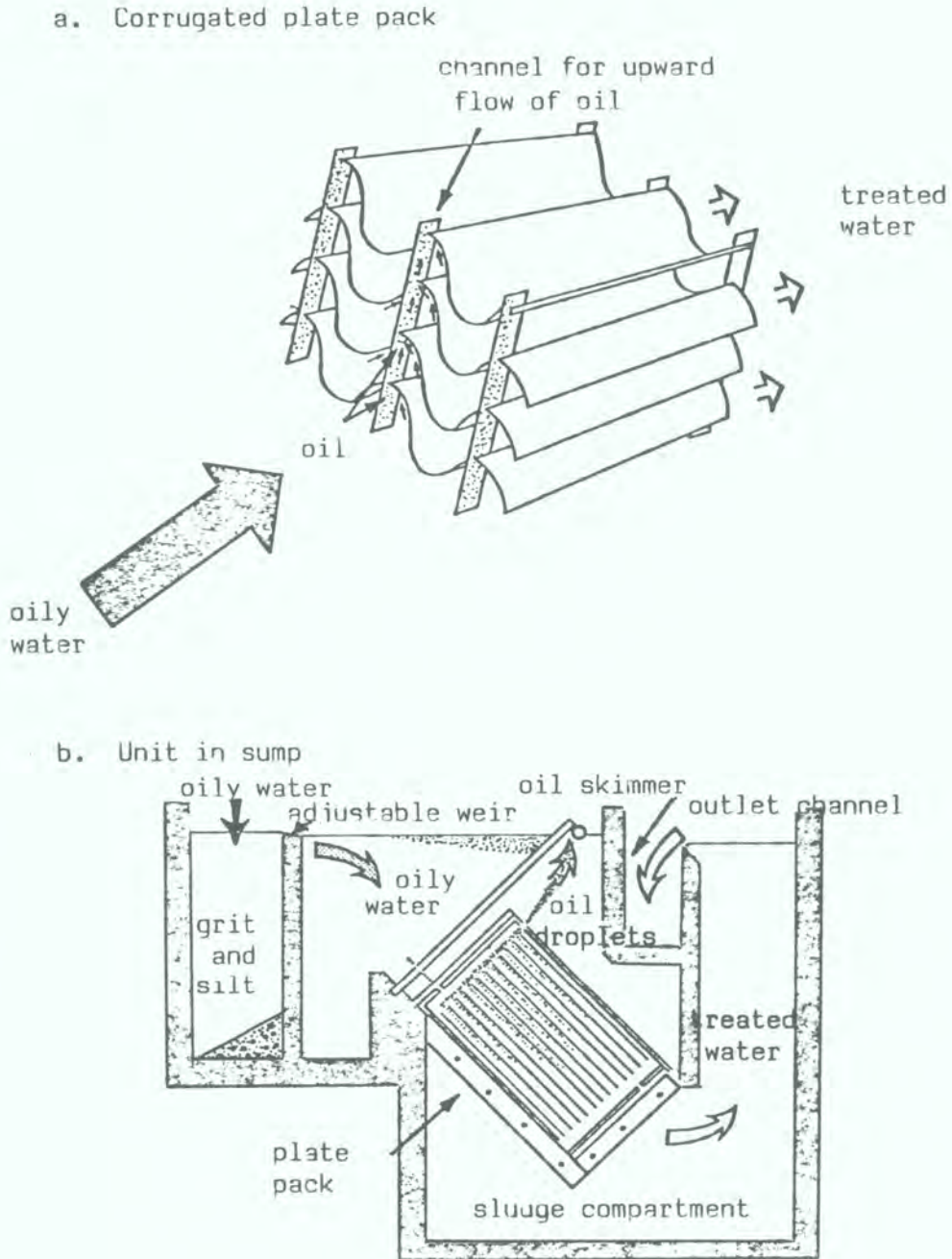

Figure IV: Corrugated plate interceptor

Figure V: Simplified production flow-sheet illustrating CJB pressure separator

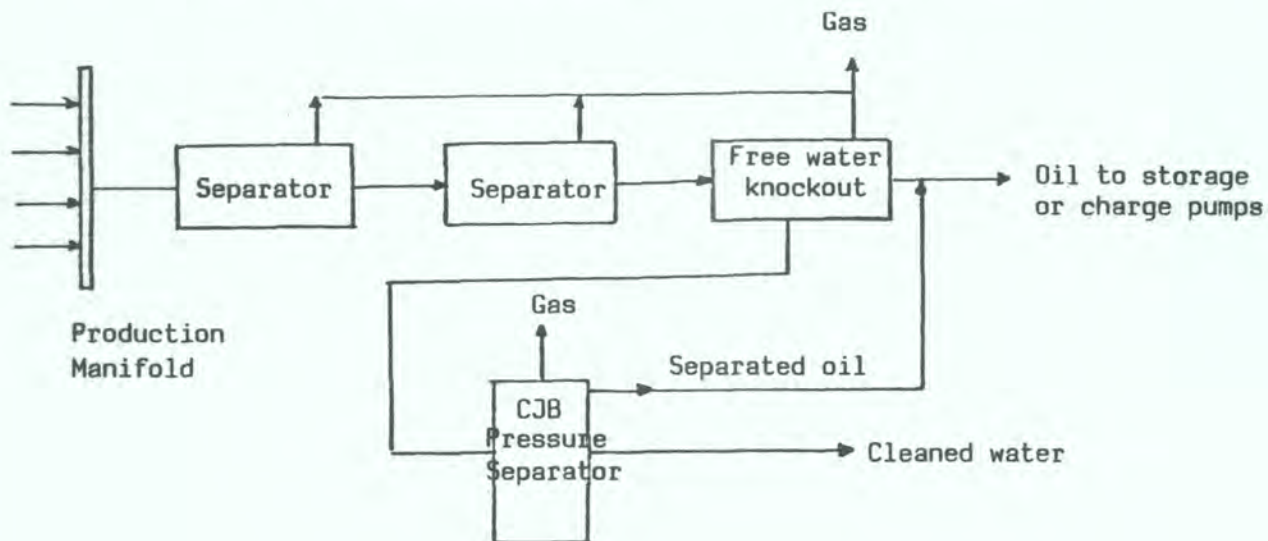
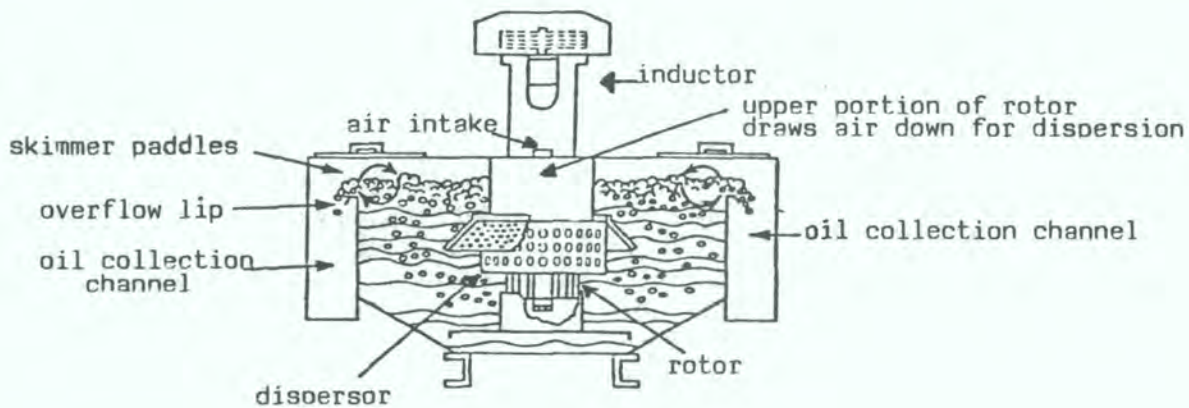
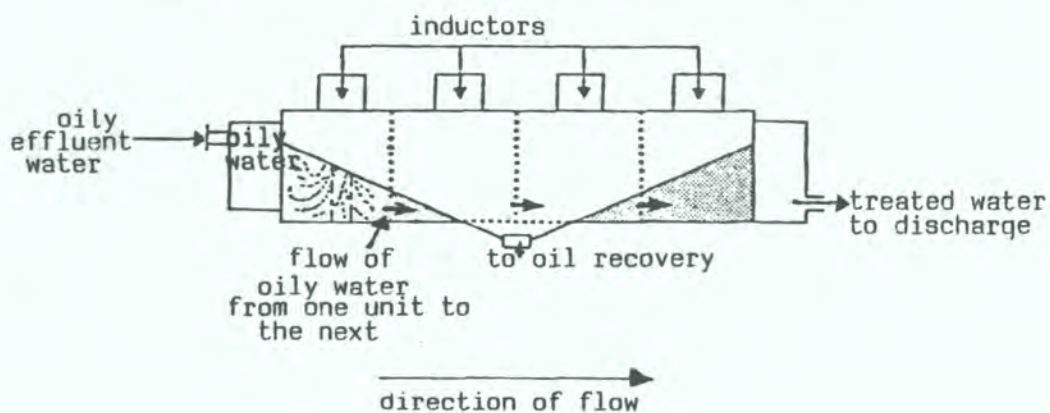

Figure VI: Gas flotation

a. Transverse section of a gas flotation unit



b. Longitudinal section of a four-unit system



### Coalescers

In these systems the coalescence of the finely dispersed oil emulsion droplets is promoted by passing the effluent stream through an oleophilic medium, consisting of either fine granular or fibrous material. A schematic diagram of the process is shown in figure VII. Separators based on this principle have found wide application in ships, but problems with plugging of coalescer packs, and the consequent need to change filter units frequently, have so far prevented their wide use at offshore oil installations.

When these units operate well they can yield effluents containing only a few parts per million of oil. They are probably capable of removing finer oil droplets than all those processes discussed hitherto, with the possible exception of dissolved gas flotation operating in the rising 'floc-blanket' mode.

Much attention has recently been directed to this plugging problem by separator manufacturers and operators. One outcome of such efforts has been the development of coalescers both for dewatering crude as well as removing oil from the aqueous phase. A simplified diagram showing units of both such types in operation together is shown in figure VIII. The de-gassed oil/water mixture from the gas separation train is fed initially to an automatically self-cleaning pre-filter to remove dry entrained solids.

The pre-filtered feed stock is then passed to the primary separator vessel where bulk water removal is achieved. The water removed in the primary separator passes to the oily water separator vessel where residual oil is removed. The substantially oil-free water can be discharged without further treatment. It is claimed that a unit has operated for some time in the Middle East yielding an effluent containing less than 15 ppm oil. The UK manufacturers, Plenty Metrol Limited, explain that the high performance of this new system is due to the use of a new type of coalescing element for separating water from heavy oils.

### Re-injection

One method of disposing of oily water on a platform is to only partially treat it and re-inject it into the formation from which the oil has been produced of some other aquifer. This is sometimes possible, but usually expensive.

### Comparative effectiveness of different treatment systems

Reliable data in this area are sparse. There are a considerable number of reports on the performance of individual separators operating at particular locations. However, since there is rarely any accompanying information on the droplet size distribution of the influents associated with such plants, it is difficult to ascertain whether a report of a high quality effluent can be attributed to the good design or good operation of the separator involved, or the fact, say, that the influent was relatively free of  $-20 \mu$  droplets.

That having been said, there is some value in looking at the results of the surveys that have been made. The most thorough was probably that carried out for the US Environmental Protection Agency (EPA) by Brown and Root prior to 1974. The object of that study was to identify what was achievable with produced water using Best Practicable Control Technology Currently Available (BPCTCA). A summary of these findings, that from a more recent one performed by the E & P Forum and recent data from North Sea installations, are given in table 1.

a) Separation process without coalescer plates

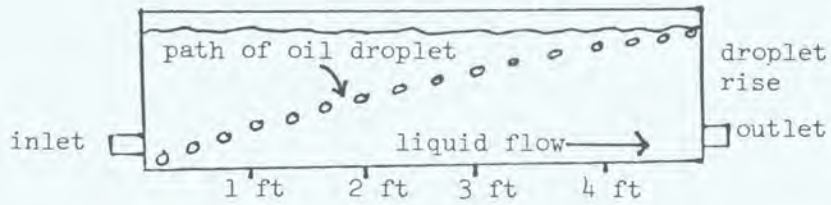

b) Separation process with coalescer plates

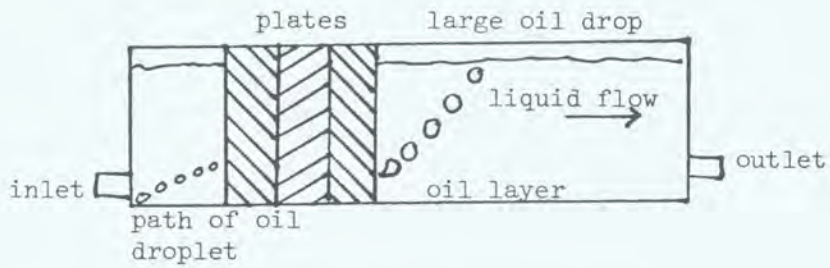

Figure VII: The essentials of a coalescer

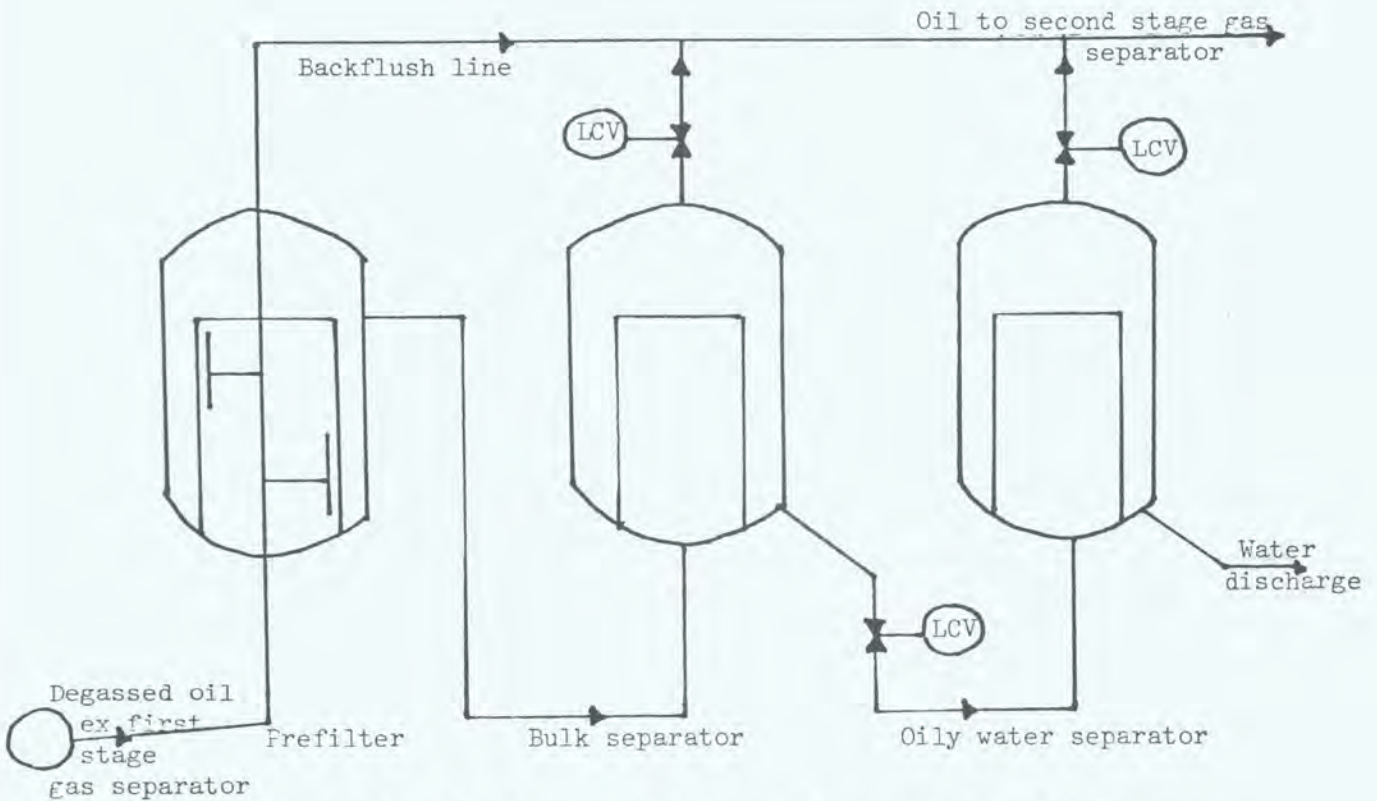

Figure VIII: Water oil separator system involving two coalescers

The wide range in the quality of the effluents obtained is probably the most striking feature of table 1. It seems likely that poor operation must be the cause of some of the high figures obtained.

#### QUANTITIES OF OIL RELEASED IN TREATED EFFLUENTS FROM A TYPICAL OFFSHORE INSTALLATION

The quantities will of course vary throughout the life of a field as the water content of the fluids produced from the wells increases. However, one can get some idea of the order of magnitude of the oil inputs involved from the following example.

Platform A - Production 100,000 Barrels/day			
	Average Quantity Barrels/day	Effluent conc. ppm Oil	Quantity of oil released per year Tonnes
Produced water	50,000	40	117
Displacement water	150,000	10	88
Drainage water			0.2*
Total oil released per year: 205.2			
*Finding from an API study probably based on much smaller platforms than Platform A.			

#### THE SETTING OF ENVIRONMENTAL DISCHARGE STANDARDS

The object in controlling these discharges and setting standards is primarily to protect the environment. There are two general approaches to this problem. One is to apply a general limit based, for instance, on best practicable technology currently available, irrespective of the actual location of the platform. The other is to tailor the discharge standard to what the local environment is thought capable of accepting without significant harm.

If one chooses the second approach there is a good case for adopting more lenient limits in, for example, high seas locations where allowance can be made for high-intensity mixing and high volume dispersion, those where there are few species sensitive to oil or where, because of ambient temperature or other reasons, any oil discharged is likely to be rapidly degraded.

It is generally recognized that actual standard levels have had to be set in situations where environmental information to assess whether a specified effluent content would harm the environment is not yet available. Nevertheless it seems desirable in the long run that this should be the approach to setting standards.

For a standard for a particular installation to have any meaning it should specify a limit to be achieved, a sampling position at which this limit should be achieved, and an analytical and calibration technique which forms the basis of the limit.



Table 1: Produced water treatment system performance

PROCESS TYPE	Brown and Root Study		E&P Forum Review			North Sea Installations	
	No of Units studied	Average of mean effluent oil concs PPM	Mean effluent oil conc achieved by best 75% of units studied PPM	Effluent oil conc. achieved 98% of time PPM	No of Units study	Range of mean effluent concs obtained with individual separators PPM	Range of mean effluent concs obtained with individual separators - monthly PPM averages
Simple Gravity separation (mainly on-shore)	52	35.4	43	140	41	14-696	150
Plate interceptors	21	56.8	78	200	12	40-250	60
Flotation systems	19	33.5	44	100	25	30-50	20?
Fibrous media coalescers	6	42	55	180			10?
Loose media coalescers	23	22	24	60			10?

\*Operating mainly on displacement water

Standard setting is largely a matter for national Governments. However, their freedom of action is partially limited by international convention requirements.

#### MARPOL 1973

The requirements of this Convention on oil platform discharges was unclear until about a year ago. On the one hand, it is stated in Article 2(3)(b)(ii) of that Convention, that discharges arising from the exploration and exploitation and associated offshore processing of sea-bed mineral resources, are not covered by it, and, on the other, regulation 21 of annex 1 to that Convention, stated that fixed and floating drilling rigs should comply with certain requirements applicable to ships of 400 and over 400 tons and be equipped as far as practicable with equipment specified in regulations 16 and 17 of that same annex.

In order to resolve this problem, the Marine Environment Protection Committee invited the E & P Forum to submit a paper suggesting an interpretation for them to consider. This they did in June 1979 and the following are some extracts from the minutes of that meeting (MEPCC XI/4):

"5.4.2. Based on information contained in the E & P Forum paper, the Committee agreed that of the three categories of discharges associated with the operation of fixed off-shore production platforms, i.e. platform drainage, production water discharge and displacement water discharge, only platform drainage water would be subject inter alia to the 1973 MARPOL Convention. It was further agreed to include this interpretation, together with appropriate diagrams showing different sources of effluents to be discharged, in a composite document covering interpretation of the 1973 MARPOL Convention as modified by the 1978 Protocol..."

(The appropriate diagram referred to is shown in this paper as figure I).

"5.4.3. With respect to the regulations of production and displacement waters, the Committee noted that these would normally come under the legal regimes of the nation exercising control over the territory on which the platform is operating and would thus normally be incorporated into any licensing procedure. However, the Committee was also aware of the fact that such regulation is the subject of multilateral legal regimes such as the 1974 Paris Convention....

"5.4.4. The Committee endorsed the suggestion by the E & P Forum that governments should promote regional agreement for common standards where appropriate, for discharge criteria of platform effluents."

In practice this means that the discharge limit imposed by MARPOL 73 on drainage water is a 100 ppm maximum outside the designated MARPOL special areas and the 12-mile coastal zone, and a 15 ppm maximum within those zones or areas.

Shelf State and Regional Sea controls - some examples.

It is clear that by far the major part of the discharges from these installations are not subject to limits fixed under a global convention, but are

matters for the shelf States working individually or together through regional sea conventions. That having been stated there is, as can be seen from table 2, a fair degree of uniformity in the limits that have been set.

It is probably true that all the standards are based on the Brown and Foot study referred to in table 1.

This led the US authorities to base their standards on the known performance of well operated flotation systems. Their 72/48 standard requires operators to keep the oil content of their discharges below a daily maximum of 72 mg/l determined by taking four grab samples in any 24 hour period, analysing them separately and averaging the results. The monthly average, which must be less than 48 mg/l, is determined by obtaining a set of four grab samples as described above on a weekly basis - four sets a month and averaging the results.

In addition to the above controls which relate to produced water discharges the US authorities also imposed a 'no visible oil' limit on discharged deck drainage, drilling muds, drill cuttings and well treatment fluids.

The one example where agreement on discharge controls has been reached on a regional seas basis is in the 1974 Paris Convention (PARCOM) (Convention for the Protection of marine pollution from land based sources). This convention covers the East Atlantic from Portugal to Norway, excluding the Baltic.

Their provisional target standard derives from a proposal from France and the UK, adopted by the Convention, that all new platforms should be equipped with the best practicable means for separating oil from discharged water, and that these means are corrugated plate interceptors or gas flotation units, or other equipment capable of reducing the average oil content of a discharge to within the range of 30-50 ppm. It therefore adopted a provisional target standard of 40 ppm. However, their acceptance of this proposal was without prejudice to their view that the control of marine pollution by crude oil by environmental quality objectives was preferable.

It was subsequently agreed that:

- (i) the provisional target standard was a monthly arithmetic mean content based on in excess of 16 grab samples taken in a month;
- (ii) the standard was based on a particular solvent extraction/infra-red analytical method.

The UK, as one of the signatories to that Convention, has accepted the provisional target standard of 40 ppm as a practical equipment performance standard for offshore platforms. All such installations on the UK shelf which make discharges of either production or displacement water are fitted with equipment envisaged by PARCOM. All apart from one have, since production commenced, been required to maintain a monthly average of content of less than 40 ppm (large installations) or 50 ppm (small installations). The consent limits require that:

- (i) the oil content should be determined by solvent extraction/infra-red spectroscopic method;
- (ii) samples should be taken at least twice per day and analysed by the approved method or a method which is demonstrably correlatable with it;

Table 2: Shelf state controls on platform discharges

STATE	Mean Oil Content Monthly Average P.P.M.	Mean Oil Content Daily Average P.P.M.	Maximum Oil content P.P.M.	% of Time that 'maximum' can be exceeded	Analytical method specified	Regional Seas Convention applicables
USA	48	72	-	-	Yes gravimetric	None
U.K	40 - 50	-	100	4	Yes Infra-red	Paris
Norway		25 (large installations) 30 (small installations)			Yes Infra-red	Paris
Denmark	40				standard - IR gravimetric used by operator	Paris
France	20				gravimetric	
Australia-State of Victoria		30	50	-	Yes continuous monitoring requirement	None
India			40			

- (iii) in any one calendar month not more than 4 per cent of these required samples are permitted to have an oil content in excess of 100 ppm;
- (iv) the volume discharged should not exceed a specified limit, based on the treatment capacity of the separation plant. Consideration will be given to a possible future requirement that the discharge be continuously monitored, once a suitable instrument has been identified.

#### LIKELY RANGE OF IMPACT FROM WELL-CONTROLLED DISCHARGES

The object of imposing costly controls on the lines discussed above must be the protection of the marine environment. However, there is never likely to be a complete absence of impact. Any individual fish which for some reason is unfortunate enough to remain in the immediate vicinity of the best controlled discharge is likely to be killed. The object of environmental control cannot be to prevent that happening, but rather to reduce as far as practicable the area around an installation where adverse effects can result. The following is an attempt to estimate the range of impact that might be expected from a large but well-controlled discharge in the North Sea.

Reviews of current literature indicate that to sensitive marine species (larval fish and Crustacea) the 96 h  $LC_{50}$  of oil hydrocarbons is equivalent to an oil-in-water concentration of about 1 ppm. The lowest equivalent concentration producing death or gross damage to larvae appears to be about 100 ppb (parts  $\times 10^{-9}$ ), while behavioural effects on adult organisms and zooplankton and stimulation of growth and photosynthesis in phytoplankton, may occur in the range 60-100 ppb. Thus, in setting an environmental quality objective we might reasonably specify that, outside a given area around a discharging platform, the water concentrations of oil hydrocarbons should not exceed 50 ppb above background. Calculations of the likely dilution characteristics of the average continuous platform discharge can be made using standard diffusion equations, assuming that the discharge is totally miscible with, and of the same density as, sea-water. For most discharges the temperature and salinity are indeed close to those of ambient sea-water. Then, under the average conditions of an effective discharge point 50 m above the sea bed, with a bottom current of  $90 \text{ m h}^{-1}$ , a horizontal diffusion coefficient of  $2,000 \text{ m}^2 \text{ h}^{-1}$ , a vertical diffusion coefficient of  $20 \text{ m}^2 \text{ h}^{-1}$  and a discharge rate of  $1,000 \text{ m}^3 \text{ h}^{-1}$ , the maximum bottom concentration from a 40 ppm discharge will be 4 ppb at a point 2,800 m downstream. In the water column, the concentration at the effective release depth, 50 m above the sea bed, falls to 50 ppb some 320 m downstream.

At the largest single UK discharge, the discharge rate could rise to a peak of  $2,500 \text{ m}^3 \text{ h}^{-1}$ , with a discharge point only 30 m above the sea bed. Under these conditions, the calculated maximum bottom concentration becomes 29 ppb at 1,000 m downstream from the source, while the concentration in the water column at the discharge depth does not fall to 50 ppb until 796 m downstream. Hence, under average water conditions, even at the peak discharge rate in the largest field's life, we can expect the proposed environmental water quality objective to be met in bottom waters outside a 1,000 m zone downstream from the installation.

It is recognized that certain of the assumptions made in the above might be questioned, but it is considered unlikely that the order of magnitude of the

predictions is far wrong. It is suggested that other regulatory authorities considering the level of any standards to be applied in their waters might attempt similar calculations before coming to firm conclusions.

#### ACKNOWLEDGEMENTS

The author acknowledges with thanks the use made in the preparation of this review of the following earlier reviews and articles:

The separation of oil from water for North Sea operations. H.M.S.O., London, 1976.

Review of discharges from offshore oil and gas production platforms into the marine environment. The Oil Industry International Exploration and Production Forum (E & P Forum) London, 1979.

BERRY W.L. Treatment of produced water discharged from US offshore and coastal oil and gas extraction industry: technology regulatory requirements.

CHAPPELL, J.J.W. and GRAY T.W. The use and performance of Interceptors. Proceedings of Seminar on the separation of oil from water for North Sea Operations. Heriot Watt University, Edinburgh, 1976.

DAVIES E.E. and WATSON P. Miniaturized separators provide high performance. World Oil, April, 1980.

TAILORED OIL SPILL CONTINGENCY PLANNING  
FOR OFFSHORE OIL BLOW-OUTS

by  
J. Ph. Poley

International Oil Industry Exploration and Production Forum,  
London, England, U.K.

ABSTRACT

The paper presents the Exploration and Production (EP) industry's views on contingency planning for potential well-blow-outs. Its approach is strongly tailored to the local situation, and calls for detailed advance consultations and agreement between Government and industry on action scenarios. Government authorities have to set national protection priorities, to decide on combat approach and resources, and to clear the way for instant mobilization and transfer. Industry fits in in supportive participation. Identification with the local scene is, obviously, a prerequisite for the effectiveness of this approach. To illustrate this, several potential pollution-combat options are considered in their relation to the local conditions. The industry has provided a new tool to assess the pollution risks for specified coastal areas (SLIKFORCAST), enabling Governments to set their priorities.

Its application is illustrated with several examples.

#### DEFINITION OF POLLUTION

"Pollution is the introduction by man, directly or indirectly, of substances or energy into the marine environment (including estuaries) resulting in such deleterious effects as

- harm to living resources, - hazard to human health, - hindrance to marine activities including fishing, - impairment of quality for use of sea-water, and - reduction of amenities."

(United Nations Group of Experts on Scientific Aspects of Marine Pollution, (GESAMP), 1974. See also MARPOL 1973, article 2.)

It is obvious from this definition that "impact on the environment" per se is not the issue, but the "impact that causes deleterious effects". In other words, it calls for local environmental quality criteria against which human activity should be judged.

#### TAILORING THE E AND P SPILL CONTINGENCY PLANS

The pollution scene of a large offshore blow-out differs drastically from that of a large tanker spill. An offshore blow-out usually provides space and time for Nature to take its toll and for man to mount responsible combat.

To minimize the consequences of an accidental offshore oil blow-out, the E and P industry strongly advocates advance consultations between national authorities, the oil industry and the public involved in order to arrive at an agreed pollution-combat scenario tailored to the local situation.



Figure I shows the framework for such an approach. (See also Ref.1)

Figure I

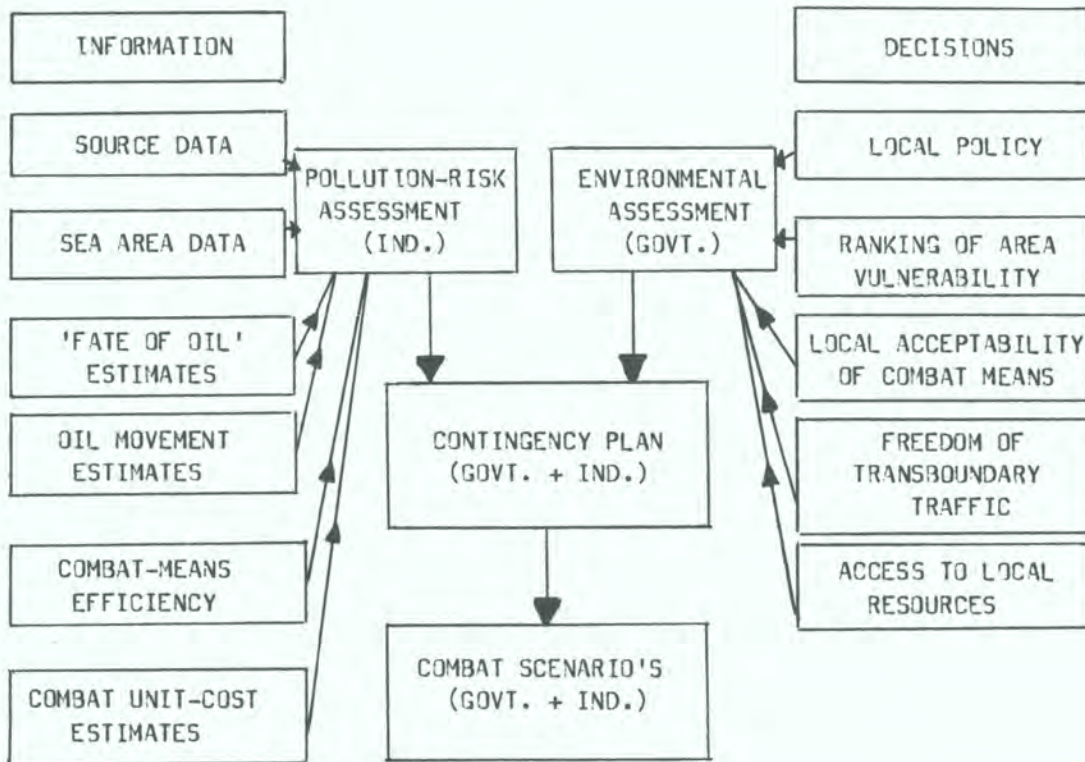

In this approach, joint Government-industry assessment of EP pollution risks and advance government decisions on combat scenarios and protection priorities, together with full-scale exercises, are mandatory.

The final scenario will be tailor-made to the local situation. Optimum use can be made of local conditions to arrive at combat decisions which may be unconventional, but which are adequate and acceptable in the actual situation.

Moreover, this industry approach provides for the incorporation of national priorities (ecological, amenity protection), local staffing (language!) and equipment, etc.

#### ESTIMATING THE RISK OF COASTAL POLLUTION

The risk of pollution of a specified coastal region depends on location of the source, composition of the oil, fate and drift of the slick at sea, and the effectiveness of spill combat measures.

The location of the spill source, its distance to coasts, hydrography, ambient weather, wind and currents, largely set the scene for the regulatory cadre, for the time-span available to protect coastal areas, and for any near-source combat action.

The composition of the oil, together with ambient sea state and temperature, will largely determine the rate of weathering of the slicks, and the stability of any emulsion formed.

The fate of spilt crude will mainly depend on the relative toll that degrading factors like evaporation, dissolution, dispersion and emulsification take under the ambient sea states and temperatures. Wind, sea state and currents govern the movement of the slick (net direction, speed), and set its residence time at sea.

Research results indicate that, given time, microbial degradation can effectively take care of oil mixed in the water column. Dependent on crude composition and sea-water temperature, degradation times of 4-20 weeks will be involved. At the higher temperatures of tropical waters the degradation will take considerably less time.

Sea state, time and space can make "leave-it-alone" a selective but effective option for contingency planning near the source.

The most effective spill-combat action is the action that can be taken near the source, before emulsification (within say, 1 mile distance): containment, recovery or dispersal.

Experience during Ekofisk-Bravo (1977) and Ixtoc 1 (1979) blow-outs has shown that effective operation of general mechanical (boom/skimmer) combat arrangements on the high seas is virtually restricted to sea states up to 2 (significant wave height 4.5 feet). There are indications that wave-compliant devices like weir-booms, and self-contained units like ZRV ropetype and SOCK skimmers may be operable through sea state 3, but further tests have to confirm this. (See also Ref. 2)

Aerial spraying of dispersant seems the most promising way of application of dispersants to the crude. It was used during Ixtoc 1 and Betelgeuse clean-ups, and it is under test in the USA, France and the UK.

Tests are also being carried out to establish the effectiveness of the chemicals in dispersing the oil.

A new tool for quantifying the estimated pollution risk for specified sea and coastal areas, SLIKFORCAST, has been provided by the E & P FORUM. Taking into account the above factors, it computes for any local scene the risk of pollution, the expected volumes and arrival times.

This quantification will provide data essential for arriving at an adequate priority setting for protective action.

Details are given in Ref. 3.

Table 1 lists the various potential applications. Figure II shows the organization of the programme. Figure III illustrates the estimated pollution risk for North Sea coastal areas from a simulated Ekofisk blow-out. Figure IV is an example of an output of slick volume and arrival time expected for the Tunisian coast, from a simulated blow-out in Tunisian waters.

Table 1    SLIKFORCAST
Multi-purpose slick forecasting tool
For:
Directing near-source spill clean-up action
Quantifying shore-pollution risks
Estimating pollution clean-up costs
Estimating the hydrocarbon load on the water column
Evaluating insurance premiums
Systematic development of contingency plans etc.

#### GOVERNMENT'S ROLE IN OILSPILL CONTINGENCY PLANNING

It is government's responsibility to protect society's resources. It has therefore the right, but also the duty to decide on the combat-scenario in the case of an oil spill. In the advocated approach these decisions should come about after advance consultations with industry and public, hopefully well in advance of a mishap.

Policy decisions have to be made on the basic approach and means in spill-combat; issues like the selective use of dispersants or 'leave-it-alone' should be settled beforehand, the role which community or industry's resources will play must be specified, as well as the procedure to settle claims, for instance.

Advance 'baseline' studies should provide adequate ecological, economic, amenity, etc. information, on which the Government can base its vulnerability ranking of sea and coastal areas. This will lead to the national protection priorities.

Decisions should be made on the tailored spill-combat actions to be taken for various potential blow-out source locations and vulnerable coastal areas. It is the Government's role to realistically balance in its decisions the expected damage (economic, ecological, aesthetic) and the costs (money, energy, resources) of protective effort. Selectively, the 'leave-it-alone' option may sometimes offer the best chances for reasonable restoration of the local ecosystem (for instance in high wave-energy coastal regions).

Provisions have to be made for ready access to active and back-up resources, for instant mobilization, and for smooth transfer of personnel and equipment, also across national frontiers.

A well-tested, military-type organization is vital for effective emergency action. It requires, for instance, a strong national spill-reponse group, an unambiguous chain of command, a well-tested communications network, smoothly operating logistics, experienced personnel, well-maintained and operative equipment,

# ORGANISATION OF THE 'SLIKFORCAST' PROGRAM

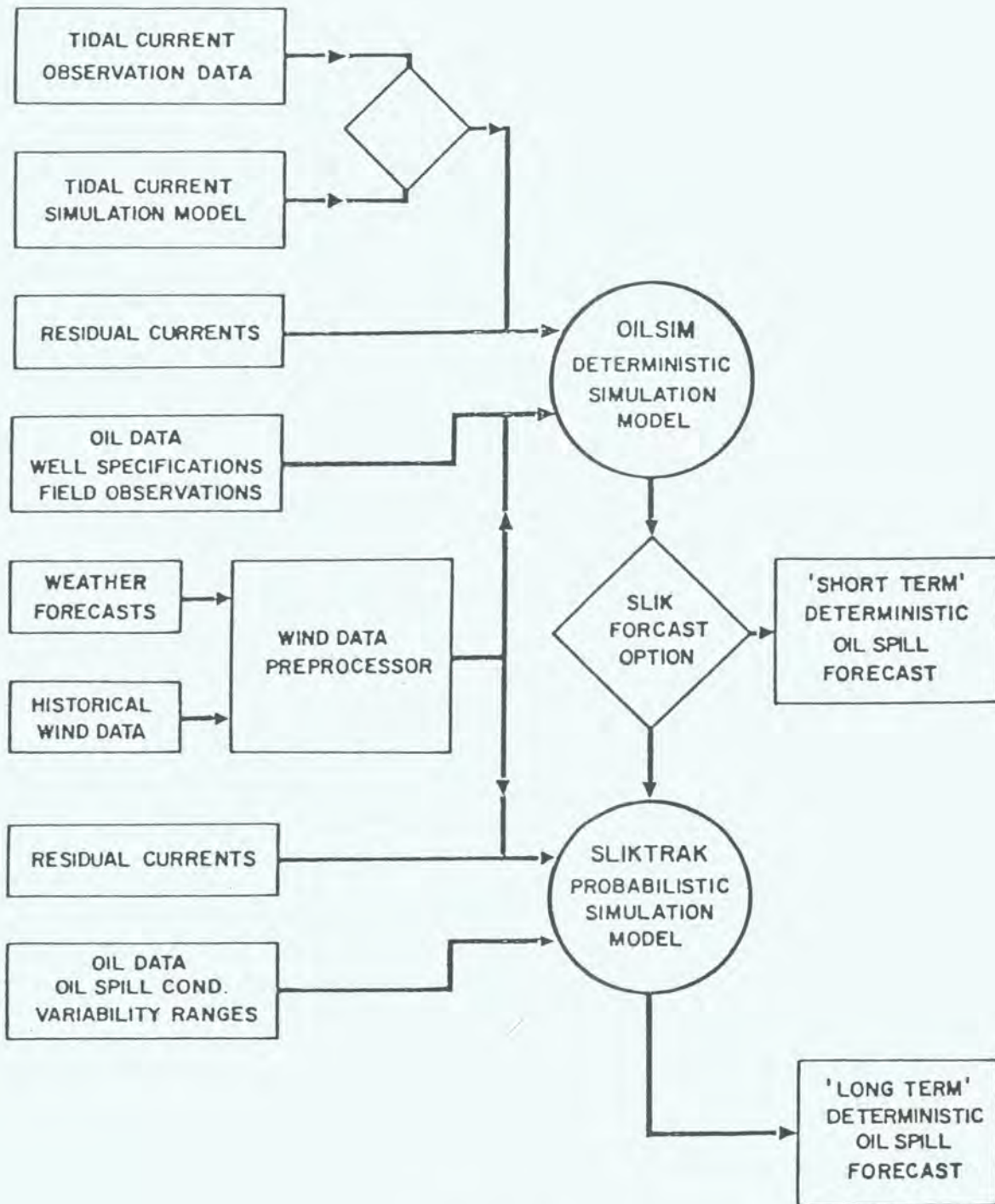

Figure II

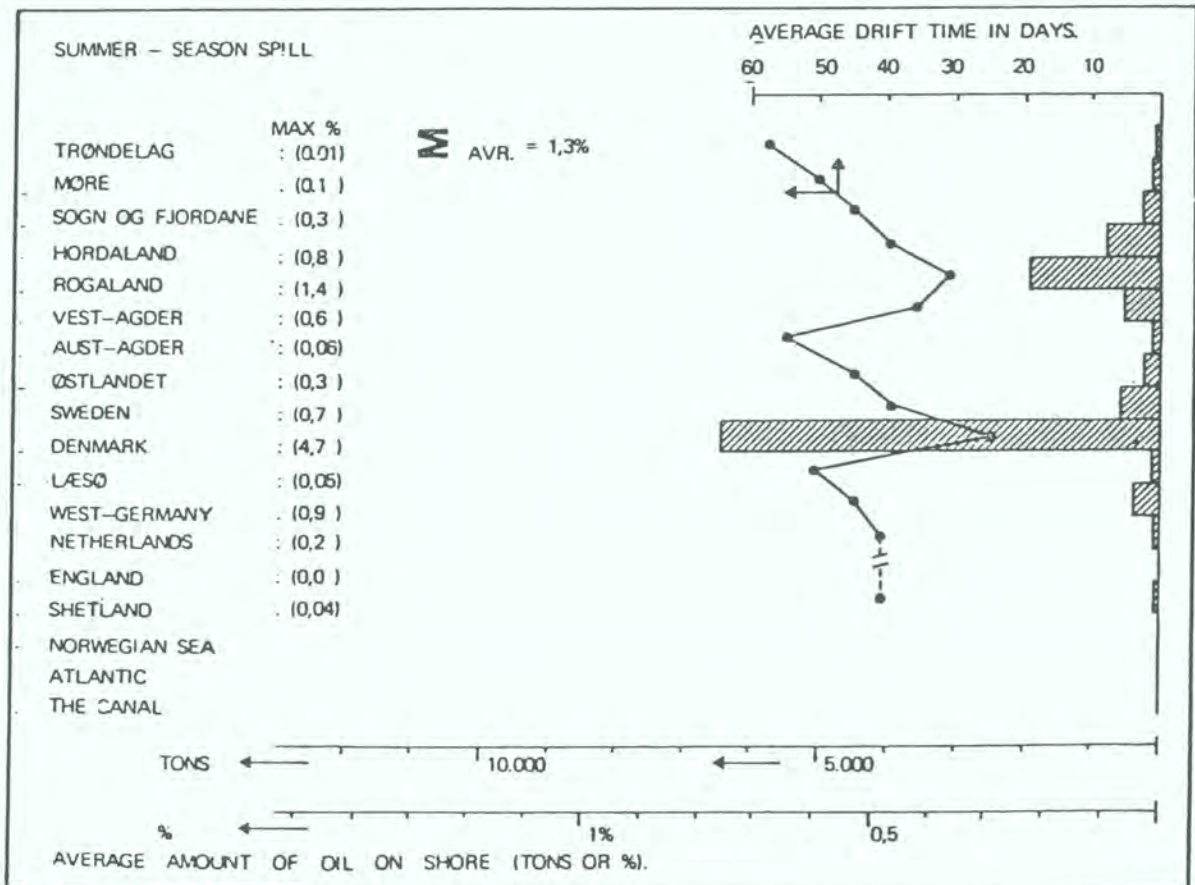
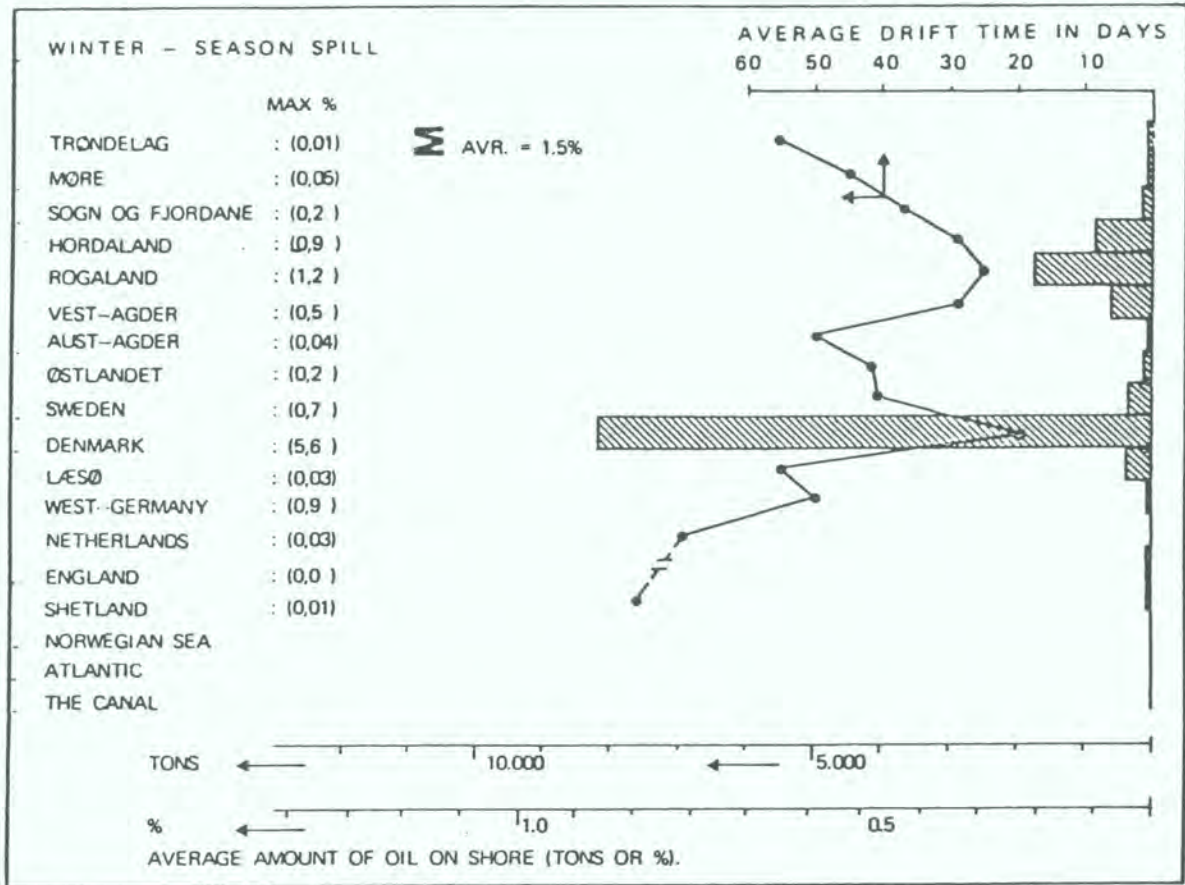

Figure III

# POLLUTION FORECAST FOR TUNISIA

Oil arrived (barrels per 5 day interval) plotted against day after incident

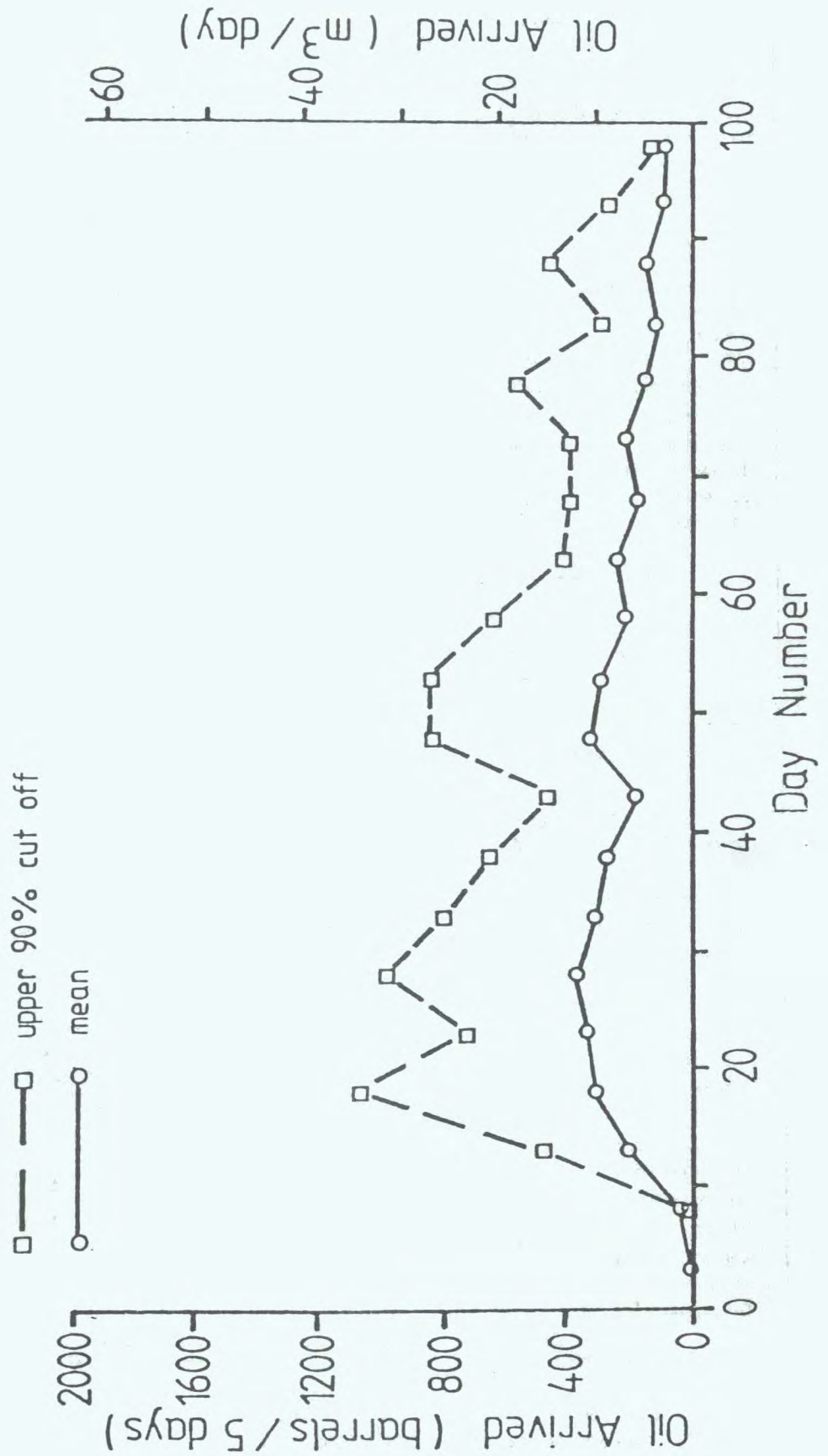

Figure IV

and an effective disposal system (see also Ref. 4).

Existing industry response capability (staff, equipment) can participate in this scenario in a supportive capacity. Its existing co-operative networks and generally available back-up expertise could be considered to advantage.

Ample consideration should be given to special opportunities for more unconventional approaches for disposal of recovered sludge; apart from newly available mousse-breaking chemicals, in many locations landfilling, landfarming, or incineration may be viable options.

#### INTERNATIONAL SPILL-COMBAT CO-OPERATION

A major oil spill will, first and foremost, remain a national affair.

Many regional pollution conventions (1969 Bonn Agreement, 1974 Baltic Convention) and Regional Seas Programmes (1976 Barcelona Convention, 1978 Kuwait Action Plan) call for some form of co-operation in the combat of a massive spill which threatens the waters of more than one nation.

Experience indicates that probably an on-the-scene integration of national spill-response groups, under the direction of the stricken country, offers the best operative framework.

It is obvious that such (emergency) co-operation demands an intensive preparation. Authority, command structure, communications (language!), availability and compatibility of equipment, adjustment of total combat-approach, etc., all have to be arranged and tested in joint exercises. Post-mortem evaluations should provide the improvements where necessary.

In such preparations, the experience of existing industry co-operatives in the same region (like GAOCMAO in the Kuwait Action Plan Region) can be used to advantage. Existing industry response capability can participate in a joint action scenario.

#### SPILL PREVENTION

Spill prevention is the most effective pollution-combat scenario.

The industry's best safeguards against pollution accidents are: well-proven standards and procedures, competent operating practice, stringent training and certification requirements, modern technology and R & D, and regular audits.

The ultimate measure in accident prevention, however, is the competent human performance.

REFERENCES

- POLEY, J.Ph,(1979) Selective oilspill combat planning for offshore E and P operations, Proc. 1979 Oilspill Conference, Los Angeles, March 1979 pp.641-647. See also Poley, J.Ph. and Callaghan D., in Proc. PETROMAR '80, p.433-447.
- GOLDB, R.S. and Mc. SHEA D.W., (1980), Implication of the Ixtoc 1 blow-out and oilspill, Proc. PETROMAR '80 Conference, Monaco, in p.743-759.
- AUDUNSON, T., DALEN. V, MATHISEN, J.P., HALDOSEN, J., KROGH, F. (1980) SLIKFORCAST - a simulation programme for oilspill emergency tracking and long-term contingency planning., Proc. PETROMAR '80 Conference, Monaco, p.513-541.
- O.C.I.M.F., 1979, Oilspill Contingency Planning, a brief Guide, London.



AUGUST 1980 OIL SPILL CLEAN-UP PROJECT - BAHRAIN REPORT

SUMMARY OF TASK FORCE OPERATIONS

by

D.J.S. Brown and A. Baxter

The Bahrain Petroleum Company Limited,  
Awali, Bahrain

ABSTRACT

The paper is a comparison of several reports relating to the clean-up operations which took place in Bahrain after a major pollution of the beaches by oil (the original source of which was not known). Task force operations involving up to 800 civilians and defence force personnel are described under the following headings: Organization, local resources, government directives, surveillance, liaison with other governments, oil containment and collection, dispersant applications, rehabilitation of beaches, rehabilitation of sea bed and analysis of spill samples.

## INTRODUCTION

On 25 August 1980, large quantities of crude oil from an unidentified source began impacting the north and west coasts of Bahrain. Reports from fishermen and coastal zone residents alerted the authorities. All oil-carrying pipelines and vessels in Bahrain's territorial waters were immediately checked for the source of the spill with negative results. However, it was ascertained that the oil had come from a north-westerly direction outside Bahrain waters. Samples taken from the spill showed that its characteristics were similar to that of Arabian light crude.

On the morning of Tuesday, 26 August, the Bahrain Petroleum Company (BAPCO) representatives met with government officials to discuss what action should be taken. However, as the magnitude of the spill became apparent (subsequently estimated at approximately 20,000 bbls), H.E. The Prime Minister requested the establishment of a Ministerial Sub-Committee to handle the clean-up operations under the Chairmanship of H.E. The Minister of Health. The Minister requested BAPCO to undertake the co-ordination of oil spill clean-up activities on behalf of the Government, to finance all expenditures involved in the clean-up operations as necessary, and maintain a record of the total cost of the clean-up operation including all expenses incurred by government agencies. BAPCO immediately agreed to this request and an organization was established under the chairmanship of BAPCO's Environmental Engineer, who in turn, reported to BAPCO's General Manager.

The organization established daily liaison meetings with all government agencies involved in clean-up operations i.e. the Ministries of Health, Commerce and Agriculture, Defence, Interior, Development and Industry, Information, Works Power and Water, and the Central Municipalities Council.

## ORGANIZATION

A Technical Sub-Committee under the Chairmanship of BAPCO's Environmental Engineer was established, a Task Force leader appointed, and an organization formed with the supervisory and administrative positions filled by the immediate secondment of 36 experienced personnel from within the BAPCO organization. The basic system of control used was that of a military operation with the affected coastline being divided into nine sectors, each sector being controlled by a supervisor and three of these sectors reporting to an Area supervisor who in turn reported directly to the Oil-on-Land Co-ordinator. Marine, Administration, Public Relations, Procurement, Logistics and Transport Co-ordinators were appointed and supplied with briefs and terms of reference.

BAPCO allocated several offices, complete with additional telephones and radio communications in order that an Oil Spill Control Centre could be set up and manned throughout the operation. The four personnel manning the Control on a rotational basis, conducted surveillance flights and attended Policy Briefings to ensure that they were fully conversant with the daily situation.

To carry out proper disposal of contaminated flotsam, an old disused quarry was checked for impermeability, and designated as a dumping and incineration area, its hard rock strata acting as a protection to the critical water table in Bahrain. Small quantities of kerosene were used to stimulate incineration.

In order that the seconded personnel should receive adequate advice on tactics, specialized equipment and environmental/social impact, the services of numerous

off-island specialists were obtained from:

- (a) Equipment manufacturers
- (b) Shareholder Oil Company Research Establishments
- (c) Warren Spring Laboratory (UK Government)
- (d) IMO/FAO United Nations Mission
- (e) Orielton Field Centre, UK

#### LOCAL RESOURCES

The various Government Ministries were approached and asked to submit immediately lists of whatever manpower and equipment they could supply to the clean-up project (see table). This resulted in the following deployment:

- (a) Bahrain Defence Force - 140 men with trucks, 3 landing  
(BDF) craft, (helicopters made available).
- (b) Bahrain State Police - 100 men with trucks  
(BSF) (helicopters made available).
- (c) Central Municipality - 170 men with trucks, vacuum tankers,  
front-end loaders and bulldozers

On full utilization of these resources, various on-island contractors were asked to submit competitive rates for available manpower and equipment. Those with acceptable rates were then deployed to complete the total Task Force of approximately 800 men, during maximum clean-up effort (see diagram).

#### GOVERNMENT DIRECTIVES

The Ministerial Committee outlined government policy for remedial action in order of priority for implementation by the Task Force:

##### Priorities:

- (1) Fourteen fishing villages (harbours, access ways and fish traps)
- (2) Public recreational beaches
- (3) Private areas from which possible recontamination could occur

##### Directives:

- (a) Dispersant would not be used near coral reefs or fishing traps/breeding areas.
- (b) The area south of Al Jazair beach would be considered of high ecological value and no onshore action would be taken in this sector.
- (c) Incineration of waste would be conducted on a small scale to prevent atmospheric pollution.
- (d) All personnel should be kept cognizant of environmental factors at all stages of the operation.

## SURVEILLANCE

Comprehensive aerial surveillance on a daily basis using the following types of helicopters from the Bahrain Defence Force and Bahrain State Police was set up:

- (1) B.D.F. - Bell Augusta 212 (with emergency floats)  
Max. speed 115 knots, 4.1 hr endurance
- (2) B.D.F. - MBB BO-105 (with emergency floats)  
Max. speed 131 knots, 2.6 hr endurance
- (3) B.S.P. - Hughes 500  
Max. speed 143 knots, 2.1 hr endurance
- (4) B.S.P. - Bell 205  
Max. speed 115 knots, 5.1 hr endurance
- (5) B.S.P. - Sikorsky Spirit  
Max. speed 151 knots, 3.8 hr endurance

The most suitable helicopter was found to be MBB BO-105 which was fitted with direction monitoring equipment (digital). Small charts were made up and flights logged and filed daily. The Hughes 500 was adequate for inshore surveillance and spray boat direction. An interesting point was the detection of large oil slicks from a distance by radar. This was only effective when seas of one to two feet prevailed, the radar picking out the oil-calmed section with little wave action.

The information obtained from aerial surveillance was used to track the route of the spill and was relayed back to the Central Control Unit for display on glass-covered maps and charts for correlation with meteorological data in order that the projection of the oil movement and subsequent deployment and contingency plans for spill containment and removal could be made effectively.

Information from aerial surveillance by the oil companies in Saudi Arabia and Qatar was also received and used to form an overall situation plan.

## LIAISON WITH OTHER GOVERNMENTS

### Saudi Arabia

Two representatives from the University of Petroleum and Minerals, Dhahran, visited the clean-up operations during the second week of the spill to discuss spill movement prediction and obtain samples of the oil.

### Kuwait

A technical delegation of five Kuwait Government officials invited by the Bahrain Government attended several of the Technical Committee meetings and inspected the beach operation to assess the scope and impact of the spill. The delegation took samples of the oil spill and suspect polluted fish for further analysis in Kuwait.

## Qatar

The Government of Qatar indicated concern that oil from this spill might reach their shores and dispatched three representatives from the Qatar General Petroleum Corporation (Onshore) to observe the task force organization, clean-up methods, and ecological effects.

### OIL CONTAINMENT AND COLLECTION

The oil accumulated in large quantities along the northern edges of jetties and breakwaters. Up to 12 vacuum tankers (2,500 gal capacity lifting 150 gal per min) were used to collect the oil which was in turn stored in reservoirs (redundant aviation fuel tankers). In order that these tankers should be used effectively, inshore booms were deployed to contain or deflect the oil. The efficiency of the vacuum tanker suction was improved by the local fabrication and fitting of "Manta Ray" type suction nozzles. Several types of skimmers and floating suction heads were mobilized but they generally proved ineffective due to the shallow depth of water along the coastal area affected.

Where the oil had emulsified or collected detritus, it proved to be too thick for the vacuum trucks, and drum-loading, air-powered vacuum cleaners were used very effectively instead.

In addition to equipment purchased directly by BAPCO on behalf of the Bahrain Government, a skimmer, lengths of boom and other items of recovery equipment were loaned by ARAMCO under the terms of the Gulf Area Oil Companies Mutual Aid Organization (GAOCMAO) agreement.

### DISPERSANT APPLICATIONS

For the short period (eight days) during which free oil floated in deep water, aerial and sea-borne spraying equipment was deployed. The whole aerial dispersant-spraying operation by helicopter was provided by ARAMCO under the terms of the GAOCMAO agreement between oil companies operating in the Region for co-ordinated response to pollution incidents.

- (i) For seaborne application, low toxicity, water-based dispersant concentrate, type O.S.D. 9517, was applied in diluted form from spray equipment recommended by Warren Spring, and proved very effective.

Application by fire pump foam eductors was also tried for a short period during dead calm weather conditions with the resultant agitation working well to disperse the thicker oil slicks.

- (ii) For aerial application a 300 gal capacity Simplex Spray Bucket (filled with 200 gal neat O.S.D. 9517 concentrate) was suspended from a Bell 212 helicopter and sprayed at 75 gal min from a bucket elevation of 50 ft above the oil. The actual positioning was directed from a Bell 206 Spotter Helicopter flying 500 ft higher.

These applications were effective when the oil appeared as sheen or thin brown streaks; however, as the weathering of the oil took place, dispersants became ineffective probably due to the unusually calm weather conditions and subsequent lack of agitation.

In order that the oil slick could be dispersed into the water column and consumed by sea-borne bacteria, various small craft were used to break up the oil by propeller action. This proved most effective, probably also due to the action of the existing dispersant already on the oil.

Some spraying was carried out in shallow water where dispersion would not readily occur; however, the rationale for this action was to "pre-treat" the various slicks before they drifted back into deeper water, allowing effective dispersion when this occurred.

No evidence of toxic effects on marine life due to dispersant spraying was noted.

An interesting and unusual phenomenon was noted in respect of the behaviour of the oil slick as weathering progressed, inasmuch as the oil would submerge and travel below the water surface carried by currents, and then reappear on the surface without warning. This was presumed to be due either to thermal clines i.e. temperature differences in various water strata which changed the relative density of the sea-water, or saline clines i.e. changes in salinity content of the sea-water which again affected its relative density.

#### REHABILITATION OF BEACHES

To facilitate beach cleaning operations and prevent continuing recontamination, 90 per cent of the workforce were deployed using rakes, shovels, wheelbarrows and plastic bags to remove many years of trash accumulation which was now heavily contaminated with oil. The operation took two weeks and at this stage it was thought that the use of mechanical equipment in beach areas would only drive the oil deeper into permeable surfaces. However, as the results of beach washing, bund entrapment, air jetting and manual netting attempts were analysed, the decision was taken by the Technical Sub-Committee to employ mechanical means to speed up the now serious threat of recontamination.

Forty miles of Bahrain's coastal zones were contaminated with oil in various stages of emulsification. The geological characteristics varied greatly, i.e. porous sea rock, mud/salt flats, reed beds, coral reefs, sandy beaches, and natural rock used as armour (rip rap).

- a) The porous rock presented an as yet unresolved problem. Attempts at hydro-jetting, detergent washing, steam washing and sand blasting were only partially effective, and 95 per cent of these sections were left for bacterial bio-degradation, which, it is estimated, will occur over the next year as these rocks were in highly oxygenated splash zones.
- b) Mud/Salt flats: where these presented a recontamination or fishing access problem, front-end loaders with large footprint sand tyres were driven in up to 3 ft of water and manoeuvred in such a manner as to produce a shaving effect, removing the oil to nearby trucks.

- c) Reed beds: In order to protect the ecosystem, these areas were left for natural bio-degradation, the recontamination being accepted. It is estimated that a 3-month period would be required for the full rehabilitation of these sections.
- d) Coral reefs: A great deal of concern was expressed during discussions on these sections as it is known that certain types of oil can temporarily retard coral growth while at the same time stimulating adjacent algae activity to the detriment of the live coral. However, in the third week of task force operations, three days of stormy weather provided nature's answer by washing clear all oil from the contaminated coral.
- e) Sandy beaches: The Committee reviewed in great detail these areas and delineated ecological and recreational regions which were in turn studied and approved by the Bahrain Government. Approximately eight miles of beach were selected for complete removal of contaminated sand to the incineration or road works areas inland. The ecologists then investigated the various sources of replacement sand within Bahrain, selecting compatible material from the south-western region of Bahrain.

The subsequent replacement operation proved to be the most time-consuming and complex exercise of the project: viz.

- (i) Efficient control over 500 trucking movements per day conducted by over 150 vehicles and 27 front-end loaders from various contractors.
- (ii) Permission to operate in restricted and private sectors of the island.
- (iii) Construction of temporary roads to reach the selected replacement material.
- (iv) Recovery of bogged down and stranded vehicles.

All problems encountered were eventually resolved, and the recreational beaches involved were returned to first-class condition by the end of September.

- f) Natural rock used as armour (prevalent along the northern coastlines to Manama) was left to natural wind and tide action by the prevailing north winds and after two months oil pollution had largely disappeared. However, on the leeward side (south facing) of breakwaters and sea walls on the western coast of Bahrain, it was found necessary to remove and clean or replace oil-covered armour rock in order to prevent recontamination of critical residential and recreational areas.

#### REHABILITATION OF SEA BED

Where emulsification and "mousse" effect occurred, the oil sank to the sea bed in shallow areas and tended to roll along the sand and manifest itself upon previously cleared areas. The following methods were used to collect these submerged substances:

- a) Wire mesh nets were constructed and used as dredges, skimmed over the sand manually, to collect emulsions for dumping in float-supported barrels.

This method was only partially effective and abandoned after two days.

- b) Chicken wire (small mesh size) in 30 ft sections with wooden supports was dragged manually through the emulsions on to the tidal area for subsequent removal by mechanical means. This method was used extensively in the recreational beach areas.
- c) A 20 ft.-long rake constructed from 6 x 6 in steel angle with 4 in.- long teeth and compressed air nozzles was fabricated and pulled behind a front-end loader in depths of up to 2 ft - the loader carrying an air compressor in its shovel to supply air to the rake at 100 psig, the theory being that the emulsion trapped in the sand would be exposed by the rake, separated from the sand by the air jets, and float to the surface. This method was effective in sand areas, but suffered damage from rocks and stones, where encountered. The oil released was collected from the water surface by oil snares.
- d) In the recreational area where the beaches were being removed and replaced, a large 10 ft wide by 2ft deep trench was formed by mechanical means along the complete foreshore in the tidal area, in such a manner that the entrapped emulsions on the sea bed tended to move into the trench with tidal action, the trenches being scoured continuously by a front-end loader. Before nightfall, the shoreward sides of the trenches were lined with absorbent matting and oil snares anchored by large stones, and each morning these were found to be covered with emulsified oil washed in by the tide. These actions were continued until clear, clean sand was obtained in the trenches and only then were the beaches replaced with only used where recreational priority superseded ecological requirements.
- e) Where heavy emulsions were encountered in water of up to 3 ft in depth, vacuum lifting equipment was found to be extremely effective, operated by divers in a manner similar to a typical domestic vacuum cleaner, the emulsion being lifted into drums and hoppers onshore or on barges.

#### ANALYSES OF SPILL SAMPLES

Efforts were made to determine the source of this spill by analyses in several laboratories in the USA and within the Region e.g. Kuwait and Saudi Arabia. None of these analyses gave any conclusive results however. In this context it should be noted that positive identification of oil spill samples is very difficult without access to equivalent reference samples from possible spill sources.

#### COST OF OPERATION

The cost of this operation is expected to total approximately 1.3 million dinars comprising the following major components:

Manpower	BD 497,000
Mechanical equipment	378,000
Aerial surveillance	71,000
Materials	342,000
Miscellaneous	12,000

Total costs are being borne by the Bahrain Government.



## RECOMMENDATIONS/CONCLUSIONS

The excellent co-ordinated response made to this spill must not allow us to assume that we are well prepared to deal with any similar incidents. Recommendations for improved capability to handle this type of emergency in future can be enumerated as follows:

1. Routine competent aerial surveillance flights of all Bahrain territorial waters must be established, with observations from such flights routed to an authority capable of initiating the necessary response action. Such surveillance flights should be complemented by information gathered by Gulf Air and other local airlines in a similarly co-ordinated manner.
2. The preparation and implementation of a National Oil Spill Contingency Plan clearly designating responsibilities, and sources of equipment, manpower and materials, must be carried out as matter of highest priority.

BAPCO should be closely involved in the formation of detailed arrangements for this Plan.

The plan should embody:

- (a) Designated representatives of Ministerial Departments who would be involved. These representatives should, as an ongoing responsibility, maintain an interest in environmental and pollution control matters;
  - (b) An ecological map of the Bahrain coastline and offshore coral reefs etc., designated areas requiring special protection, restricted areas for dispersant usage, etc;
  - (c) A survey of currents and tidal movements in Bahrain territorial/coastal waters taking account of seasonal variations in these data.
3. Establishment of the Marine Emergency Mutual Aid Centre (MEMAC), which is already a matter of considerable concern to the Bahrain Government, should also be expedited on a most urgent basis to enable Regional States to respond to major oil pollution incidents in a properly co-ordinated manner, as due to the geography of the region and climatic conditions, any spill of a significant size will affect more than one State.
  4. Availability of suitable, readily deployable, mechanical beach cleaning equipment should be investigated on an urgent basis (similar to the now discontinued Brighton beach cleaner), to speed up future beach clean-up operations.
  5. Provision of aerial dispersant spray buckets/pods for use by BDF/BSP helicopters, should be considered, to enable an immediate response operation to be carried out against a future approaching spill in deep water where suitable low toxicity dispersants can be effectively engaged.

6. Experience with the organization established to tackle this spill has demonstrated the great importance of appointing a single overall co-ordinator for the Response Task Force with the widest powers to implement necessary action following Government concurrence. The fact that this Co-ordinator had contact with the Bahrain Government at Ministerial level was an essential factor in maintaining an effective clean-up operation.

The initial prompt decision by the Bahrain Government to appoint an overall co-ordinator under their authority was the most important factor contributing to an effective clean-up operation.

#### ACKNOWLEDGEMENTS

We wish to express our sincere appreciation to the Bahrain Government and specifically to H.E. Dr. Ali Fakhro, Minister of Health, for the opportunity to present this report to the Workshop.

OIL SPILL - BAHRAIN

CALENDAR OF EVENTS

1990

- 25 August : Oil sighted on Bahrain north-west coast
- 26 August : Bahrain Government appoints a Ministerial Sub-Committee who request BAPCO to undertake co-ordination of oil spill clean-up activities.
- 27 August : Oil now moving south down Bahrain's west coast past Umm Na'san. Vacuum tankers deployed at Budayyi Jetty. Oil samples taken for analysis. Aerial surveillance confirms extent of spill (20,000 barrels).
- 29 August : Oil now impacting coastline from Muharraq Bridge anti-clockwise around Bahrain to Zallaq Beach. BDF landing craft deployed offshore spraying dispersant. Aerial spraying by helicopters in operation. Coastguard high speed launches deployed for agitation of slicks.
- 2 September : Only small slicks remain offshore. Spraying from helicopters now terminated. Submerged oil observed for first time. Oil due to water salinity and thermal differences (thermal clines) appears to be sinking in deep water and re-appearing on the surface several hours later in shallow water.
- 6 September : All experiments and tests with regard to beach cleaning now completed and analyses dictate that some rigorous action is now required (deployment of mechanical equipment). New supplies of oil repellent for beach use, booms and skimmers arrive at Zallaq today. Large quantities of oil-soaked seaweed now being deposited on beaches. Arrangements made for oil-affected birds to be delivered to Al-Areen Wild Life Sanctuary.
- 7 September : Oil slick is now impacting entire north and west coasts of Bahrain. Large slick has been observed moving round Ras Al Jar one and a half miles north on the eastern coast. Barge Buri fitted out with vacuum lifting equipment and booms for oil collection operations on east coast. 50 barrels of oil repellent dispersant moving to Ras Al Jamal.

- 8 September : Large quantities of absorbent materials and oil snares delivered to Zallaq. Further quantities of boom arrived from ARAMCO, UK and USA. Oil slick on east coast has now moved south of Bahrain. Barge operation standing by at Sitra.
- 10 September : Large quantities of oil-soaked sea-grass still arriving on the coast. First reports on ecological effect submitted. Additional nine supervisors arriving from UK. Attempts at skimming oil in shallow water now abandoned in favour of vacuum trucks and other vacuum lifting devices. Additional 3,000 oil snares ordered. Large quantities of dead cormorants now being observed in coastal areas. Removal of contaminated sand in recreational areas by mechanical means now in progress.
- 16 September : Laying of new sand in recreational areas begins. Fishermen's access areas now back in operation. Oiled sea-grass continues to come ashore.
- 18 September : Clouds of oily grey water now apparent in all shallow areas (bloom affect). Oiled sea-grass still coming ashore.
- 20 September : Underwater ploughing device deployed at Al-Jazair. Attempts at netting oiled sea-grass offshore in hand. All traces of oil and sheen have now disappeared offshore.
- 27 September : Rough water, the first for four weeks, now forecast.
- 4 October : Four days of heavy weather assisted in removing contamination from coral reefs and rock on northern shores. However, further large quantities of oiled sea-grass now being encountered. All recreational beaches returned to Municipality for continuing clean-up on janitorial basis. Sub-surface sediments observed over a 15 sq.mile area north-west of Bahrain and assumed to be oil spill residue. Samples taken subsequently confirmed this. New reports and rumours of a further impending oil spill from an offshore oil-well blow-out were confirmed this morning by a telephone call to ARAMCO.
- 11 October : Beach cleaning and rehabilitation, using now established methods, will proceed until mid-November.

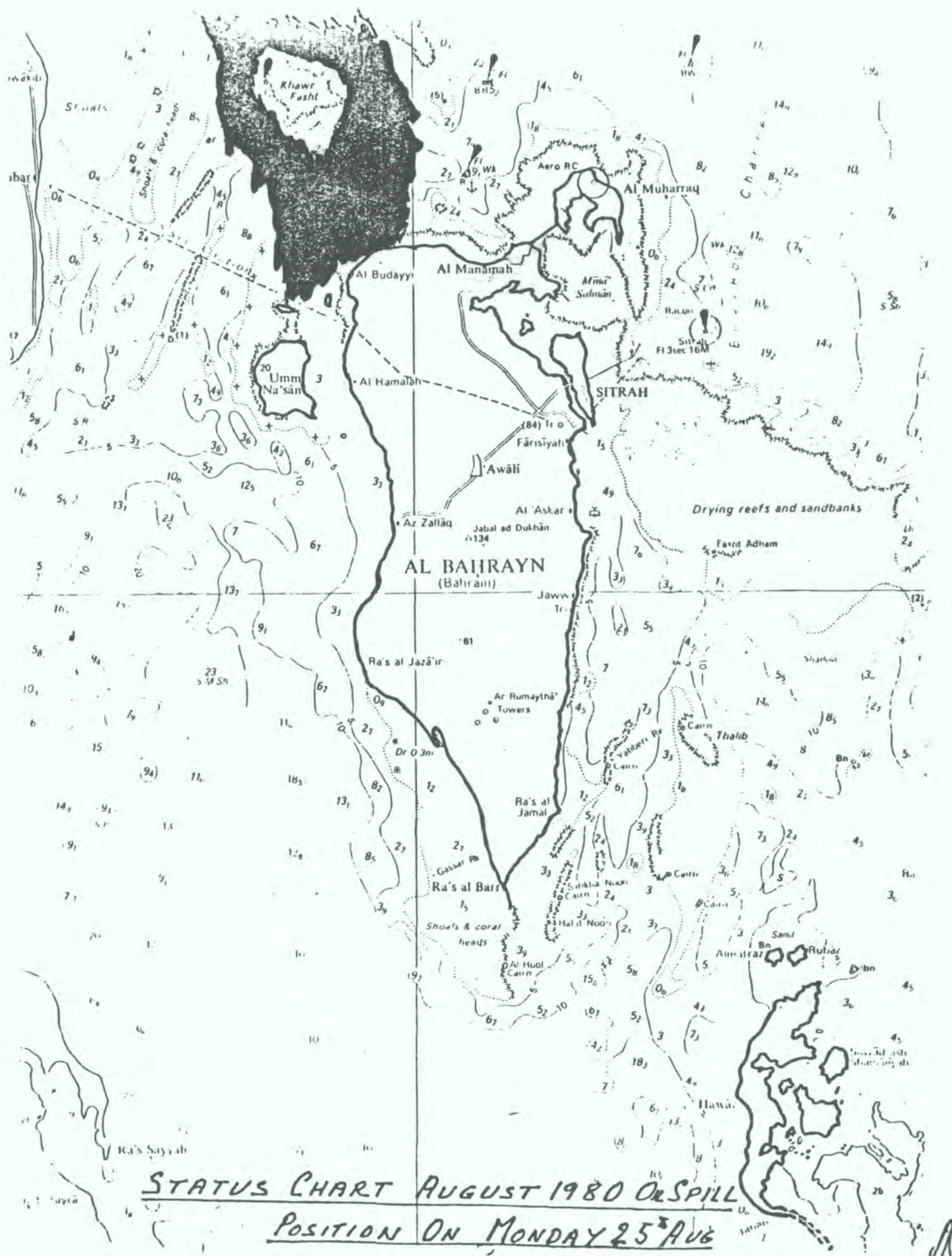

STATUS CHART AUGUST 1980 OR SPILL  
POSITION ON MONDAY 25 AUG

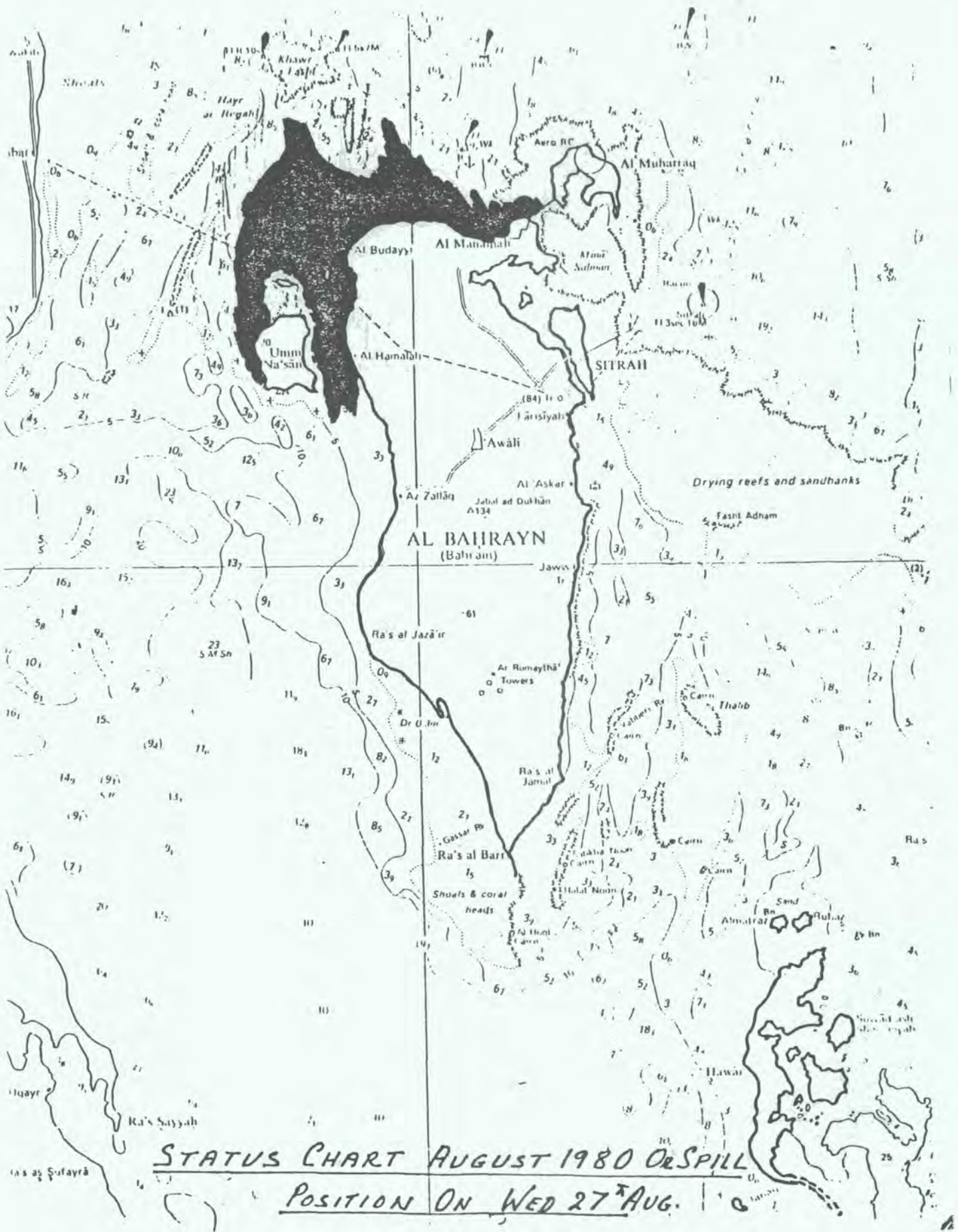
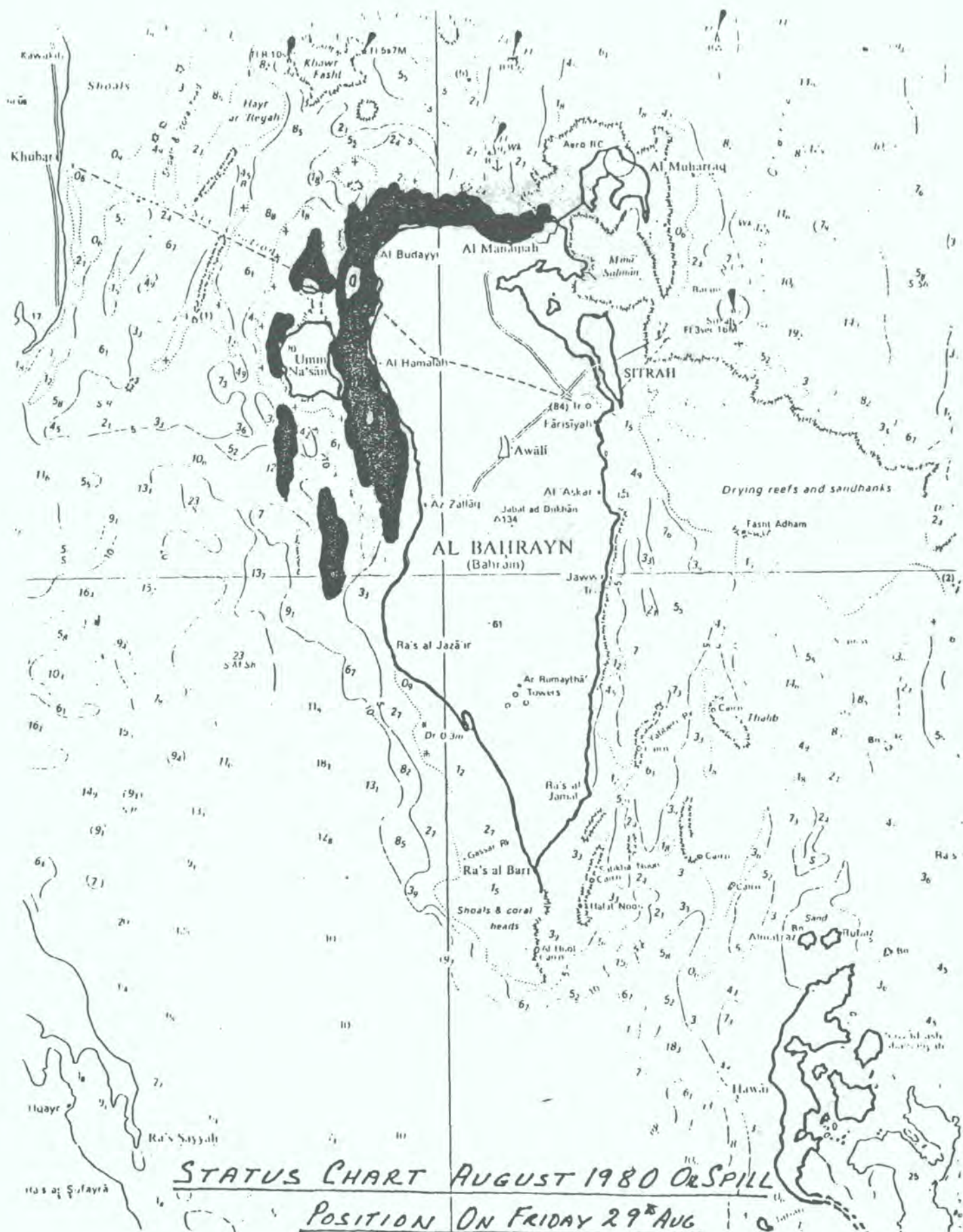
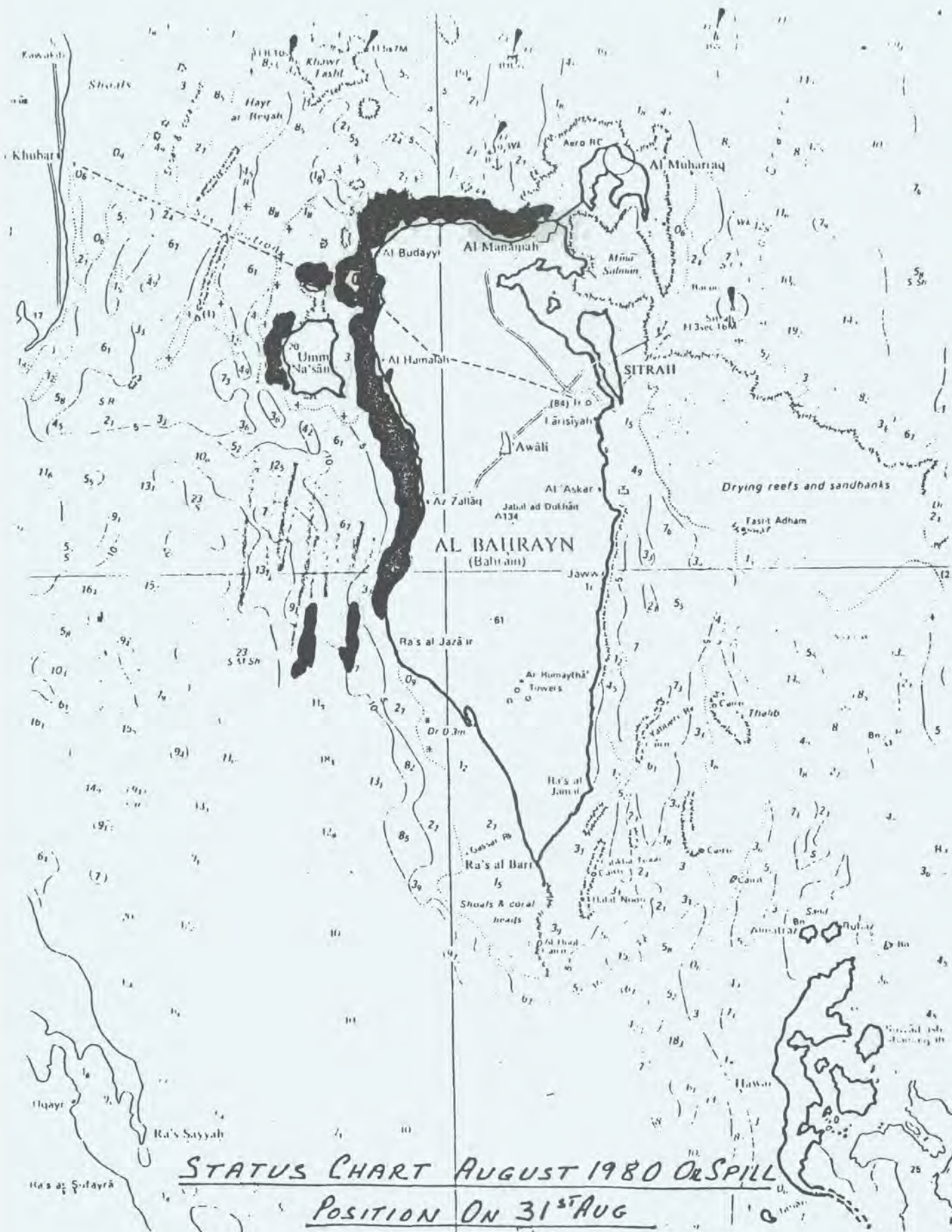

Chart 2





STATUS CHART AUGUST 1980 OIL SPILL  
POSITION ON 31ST AUG

Chart 4



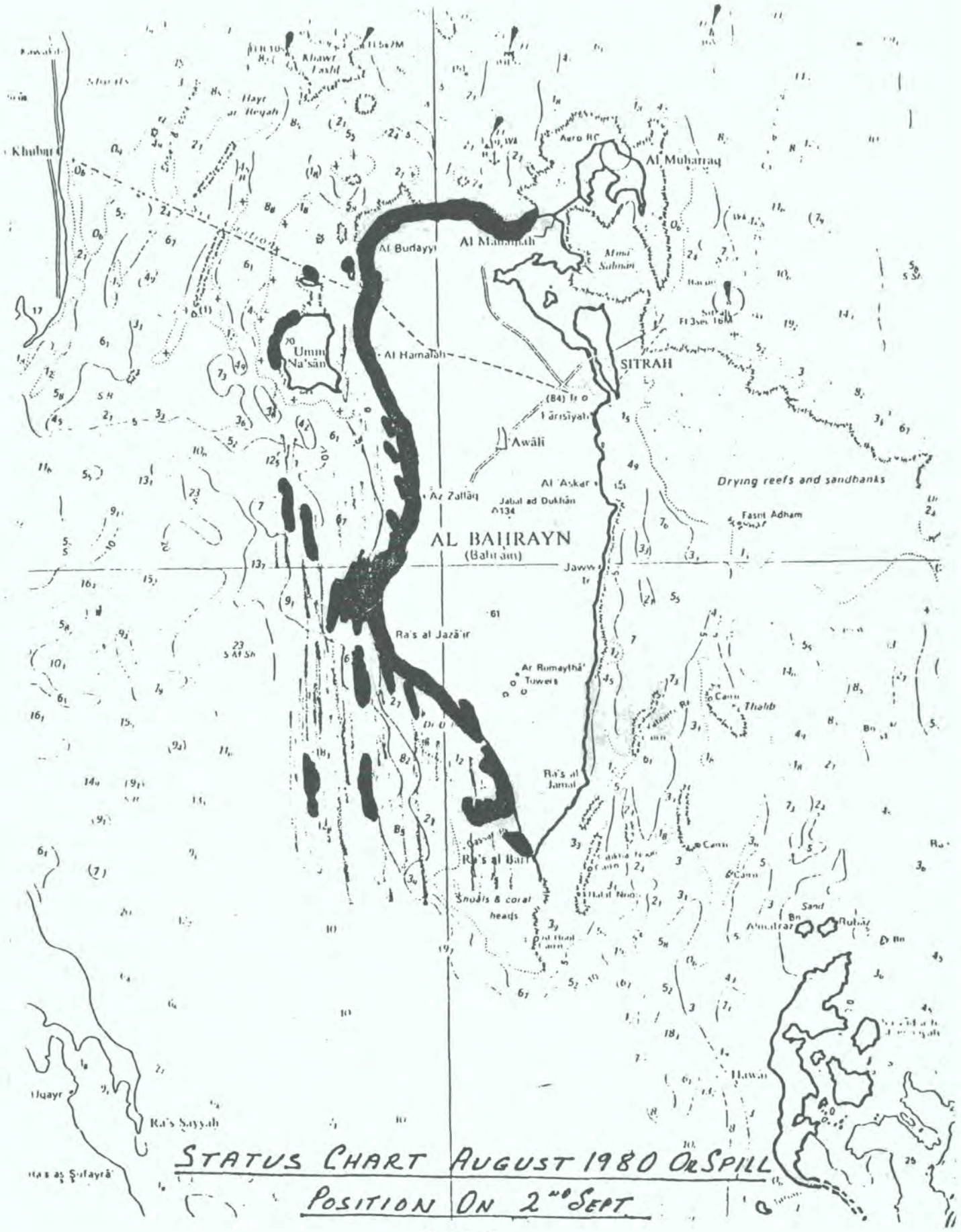

STATUS CHART AUGUST 1980 OIL SPILL  
POSITION ON 2<sup>nd</sup> SEPT.

Chart 5



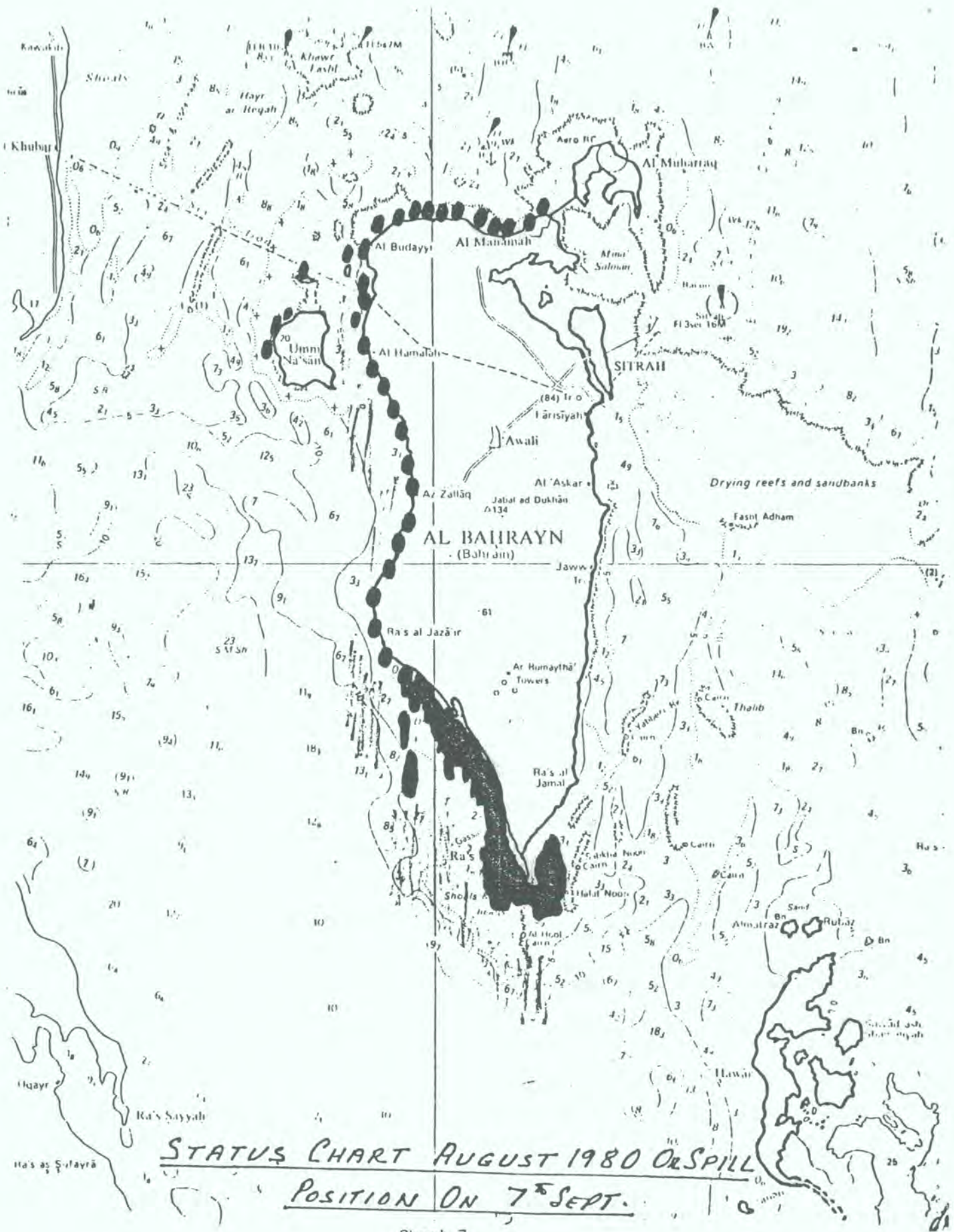

STATUS CHART AUGUST 1980 OR SPILL

POSITION ON 7<sup>th</sup> SEPT.

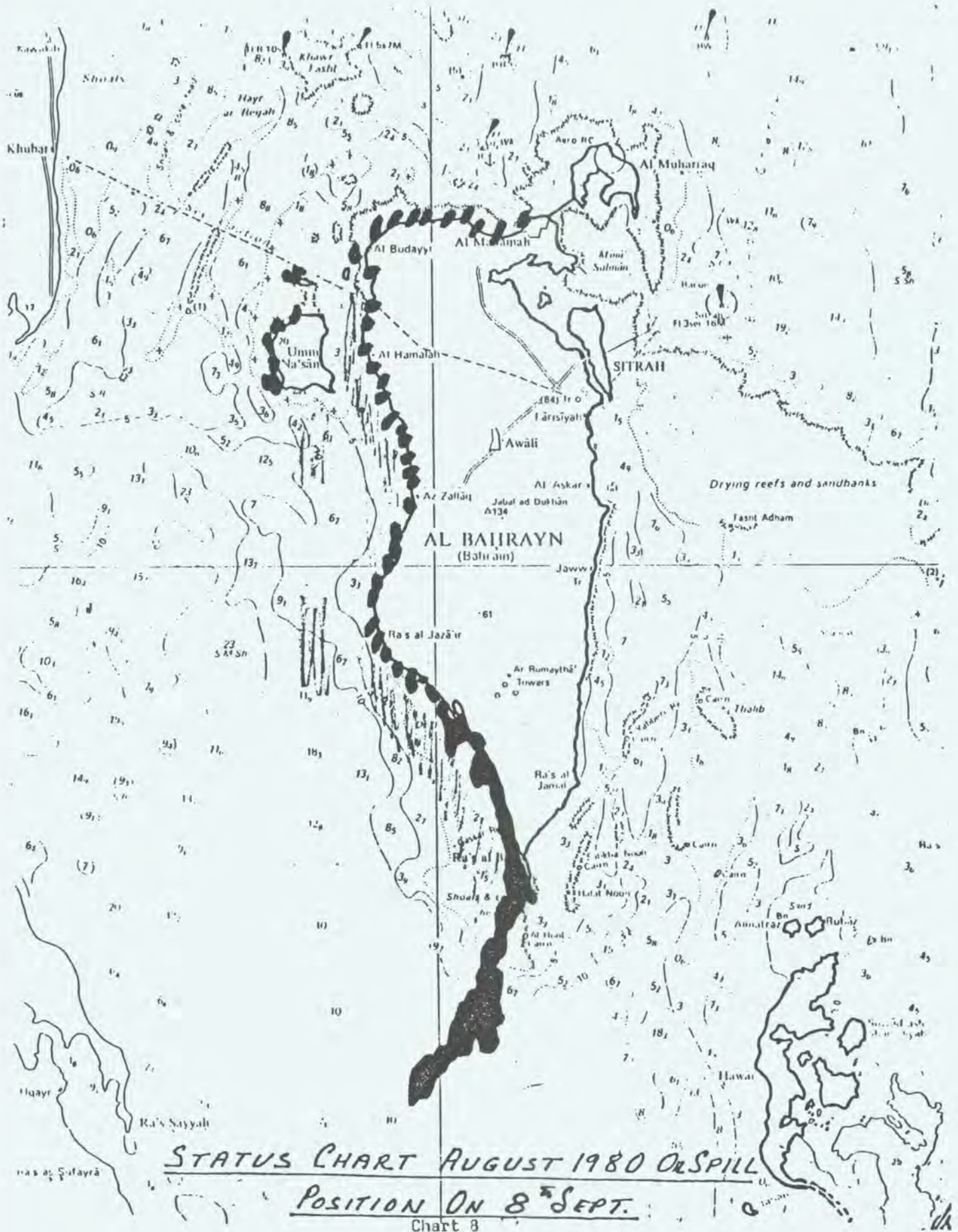

Table 1

OIL SPILL TECHNICAL SUB-COMMITTEE

STATUS REPORT - Week Ending 5 September 1980

TABULATION OF MANPOWER AND EQUIPMENT IN USE

A G E N C Y		D A T E					
		31 Aug.	Sept. 1	2	3	4	5
BAHRAIN DEFENCE FORCE		179	147	137	137	137	
POLICE *		90	105	90	90	98	
MUNICIPALITY		72	88	168	169	158	
C O N T R A C T O R S	A. M. A.	50	79	96	107	106	
	RAMSIS	10	10	13	13	13	
	MCSC	-	22	22	-	-	
	EMDS	-	7	7	7	7	NO WORK
	BUCHERRY	-	5	34	34	39	NO WORK
	N. A. M.	-	-	67	68	67	NO WORK
	AMIRI	-	-	43	48	47	NO WORK
	MAMEERI	-	-	11	11	11	NO WORK
	ABUTAKI	-	-	-	23	23	NO WORK
	SMS	-	-	-	41	41	NO WORK
BAPCO		30	30	30	30	30	
MANPOWER TOTAL		431	493	718	778	777	
PAICO SENIOR SUPERVISORS (Already included BAPCO above)		12	12	12	12	12	
FRONT END LOADERS		3	5	5	6	8	
VACUUM TRUCKS		9	9	10	9	8	
TIPPERS		18	34	31	32	36	
TRUCK LOAD TRASH		50	50	50	75	100	
T O T A L							325

\*Police working two-four hour shifts i.e. 1 effective 8 hr. shift

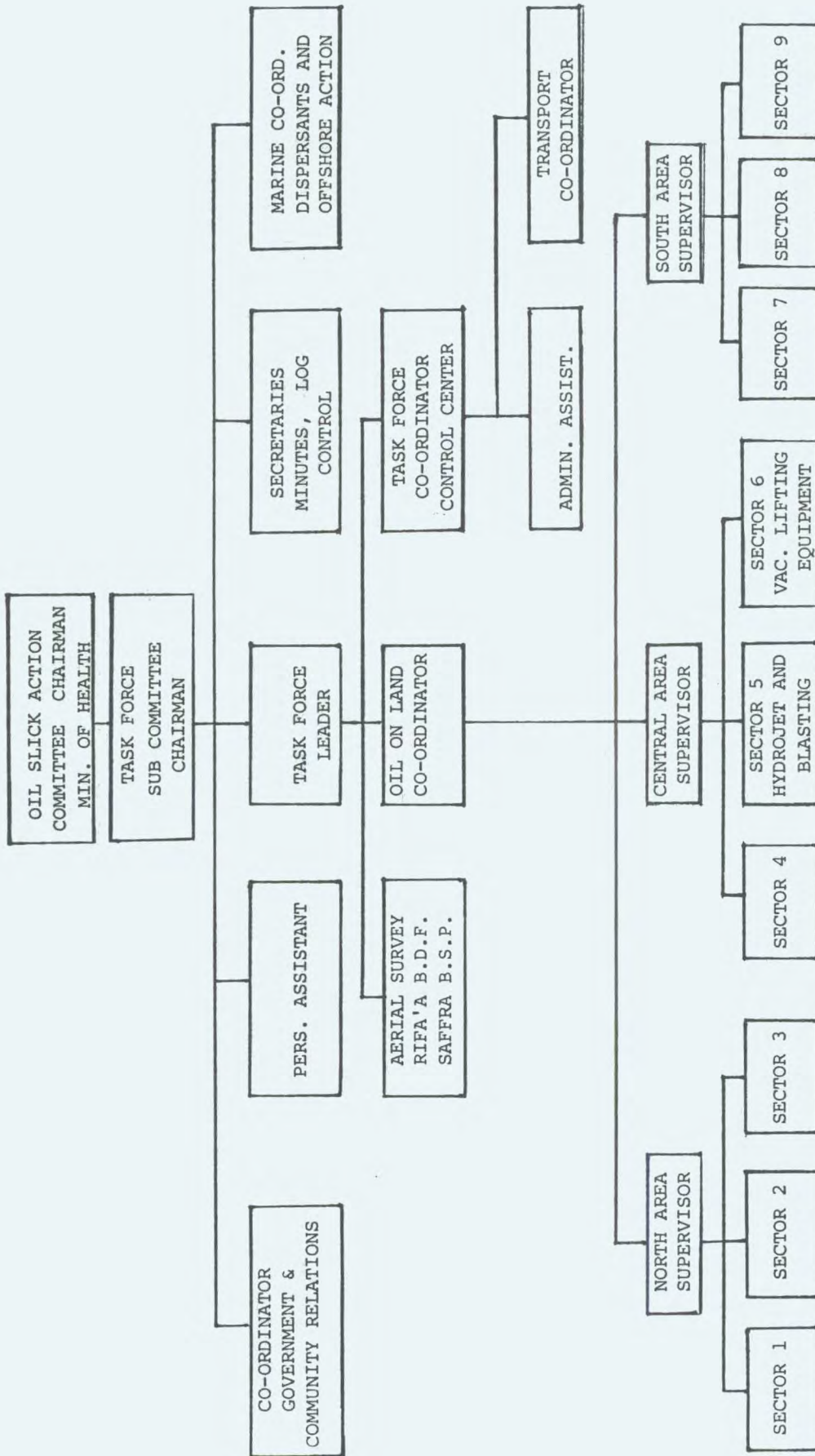

800 MEN, TRANSPORT, EQUIPMENT ASSIGNED TO SECTORS BY CONTROL

Table 2

OIL SLICK MOVEMENTS IN THE KUWAIT ACTION PLAN REGION

by

W. J. Lehr and H. M. Cekirge

University of Petroleum & Minerals,  
Dhahran, Saudi Arabia

ABSTRACT

Using seasonal average surface currents and wind vectors, a computer simulation of projected oil slick drift trajectories and impact locations in the Kuwait Action Plan (KAP) Region is constructed. Based on 72 simulated oil spill locations, high pollution risk coastlines are identified.

## INTRODUCTION

As the world centre of the oil industry, the KAP Region faces a high potential danger from oil pollution. One factor in the location assignment of oil pollution control task forces is the assessment of the danger of contamination for various shorelines in the Region. Therefore, the authors have constructed a model for estimating the trajectory of oil spills for various locations in the Region based upon seasonal average climatic data. While chiefly of use for statistical conclusions, the model could be used by oil spill detection agencies to provide an expected spill path on the basis of minimal information about such a spill. Such a "first guess" trajectory would, for example, help assess governmental responsibility for clean-up in the region with its multinational coastline. It could also determine whether such a spill is likely to come ashore in any area where it could do severe damage and hence must be further monitored and controlled, or whether only minimal risk is involved and less urgent response required.

## DESCRIPTION OF THE MODEL

Due to certain limitations on the data available, only offshore oil spills were considered. By offshore, the authors mean spills that are far enough from the shore for their movements to be relatively unaffected by coastal currents. The International Maritime Organization (IMO) has used as a basis for such spills the distance of 25 miles, but it could possibly be less. The movements of the oil slicks are presumed to be determined by the overall drift current, local tidal currents and wind-induced currents. Current and wind data were based upon Tetra Tech Co. reports to the Royal Commission for Jubail and Yanbu. Tetra Tech acquired its data from local observation and sources, and external sources including the National Climatic Center in Ashville, North Carolina and the U.S. Naval Hydrographic Office. Using the above data, the sea area of the region was divided into 72 grid blocks, each of a half degree longitude in width and a half degree in latitude in height, and an overall seasonal current and wind vector for each grid block was assigned (see figure I). From these vectors a seasonal oil slick drift vector was computed for each block.

Considerable dispute exists over the proper determination of this drift vector. For example, Stokes developed a theory of wind-induced current which predicts a Coriolis-caused drift angle between the wind and current directions of up to 45. Experiments, however, have yielded values deviating significantly from Stokes's predictions. Actual spill observations have also shown widespread variation in drift angle. Rath and Francis suggest that field tests for specific sites should be conducted to determine a proper value. In the absence of such field tests, we have adopted the formula of Lissauer and Bacon and set the drift angle equal to zero, although this could easily be modified if observational data yielded a different result.

Similarly, there is no unanimous opinion of the strength of the surface current induced by the wind, with estimates anywhere from 1 to 10 per cent of the wind velocity. Again following Lissauer and Bacon, the authors have adopted a wind factor of 3.5 per cent of the wind speed at 10 metres above the sea surface. While most models simply add this wind-caused current to the normal drift current, Schwartzberg has determined empirically that there is a coupling effect between the two vectors and that a more appropriate equation for the total oil slick drift vector would be the wind current vector plus 56 per cent of the normal current vector. This was the formula used for this model.



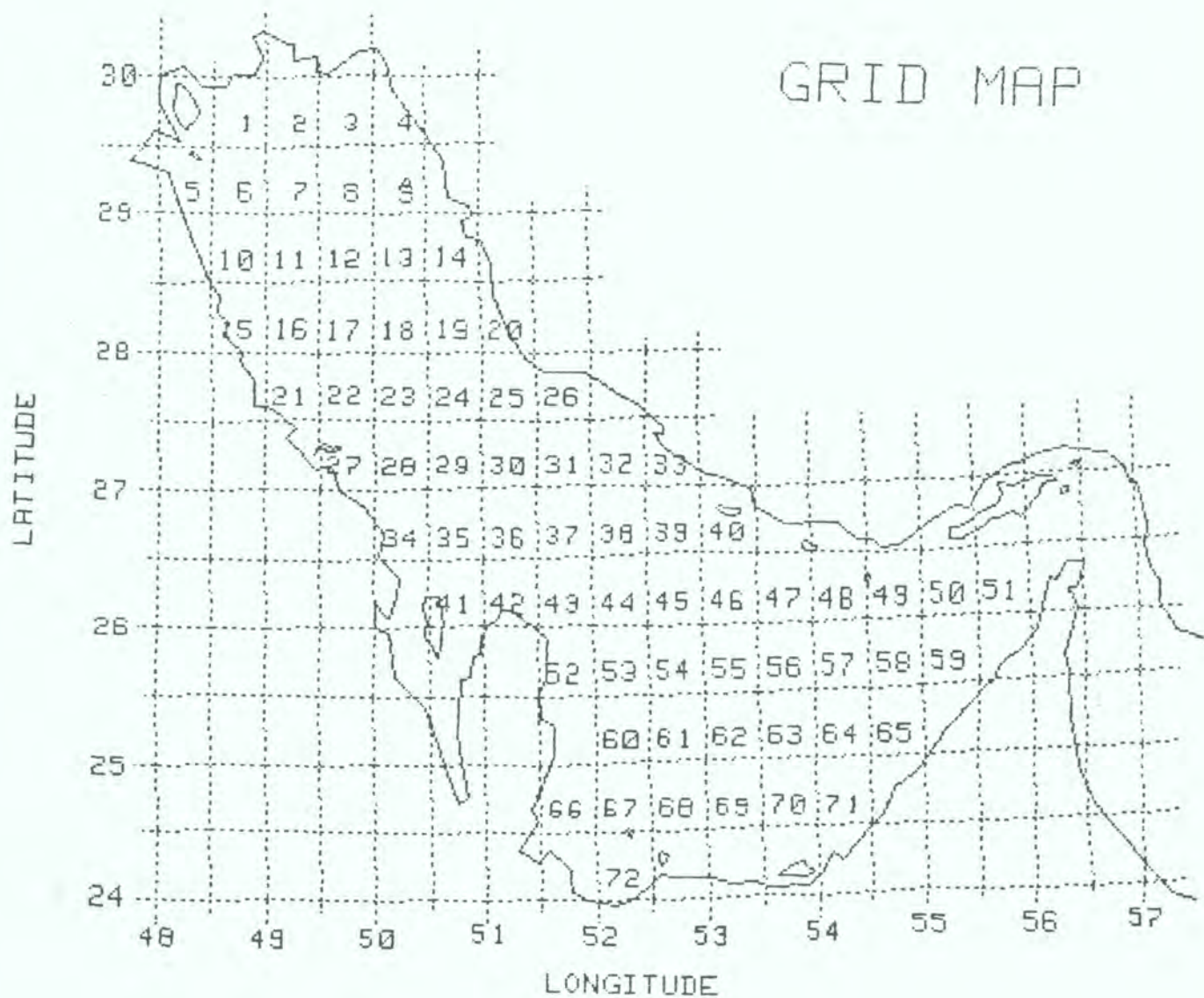

Figure I: The Grid Map

Using these seasonal drift vectors for the initial location of the spill, its expected co-ordinates were tracked every 12 hours, except during the summer season when smaller values for the drift vectors made a 24-hour period more practical. Thus it was possible not only to estimate the predicted path of the spill but also its estimated time of impact with the shoreline as well.

Figures II and III present examples of some simulated spill trajectories. The small square represents the hypothetical initial spill locations and the dash line the predicted path with each dash representing a 12-hour time span (in the summer season a 24-hour time span). Since the space between each dash also represents a 12-hour period, the number of days until estimated impact with the shoreline can be calculated by simply connecting the number of dashes.

### CONCLUSIONS

Assuming no prior preference for any site in the Region as an oil spill origin it was possible to determine those coastal areas which run a high risk of oil pollution. Dividing the coast of the Region into six areas (see figure IV) the following table was constructed using the computer trajectory predictions starting from all the squares except square 20, whose centre lies inland. The numbers represent the percentage of oil spills which reached the specified coastal area.

	Winter -----	Spring -----	Summer -----	Autumn -----
Area A	7	16	4	10
Area B	1	3	39	19
Area C	21	22	14	22
Area D	18	20	21	12
Area E	43	23	17	27
Area F	10	16	4	9

(Numbers may not add to 100 due to rounding)

Coastlines not included in these six areas had no predicted oil spill impacts.

From the table we can conclude that the Southern Iranian coastline (Area E) is most vulnerable to oil pollution, although the Emirate coasts (Areas C and D) also show considerable risk potential. The other coasts are relatively safe except for the Southern Arabia and Qatar region (Area B) which shows a high risk of oil drifts in summer and autumn. Northern Arabia (Area A), while fairly safe from spills, has its greatest pollution risk season in the spring. This may suggest that any oil spill task force for Saudi Arabia should be stationed in the north during the first part of the year and moved south for summer and autumn.

Further refinements of this model which will allow improvement in the estimation of the drift current, expand predicative capabilities to the Gulf of Bahrain and the Strait of Hormuz, and predict spread and degradation of the spill by dispersion, evaporation and other natural factors, are currently under development by the authors.

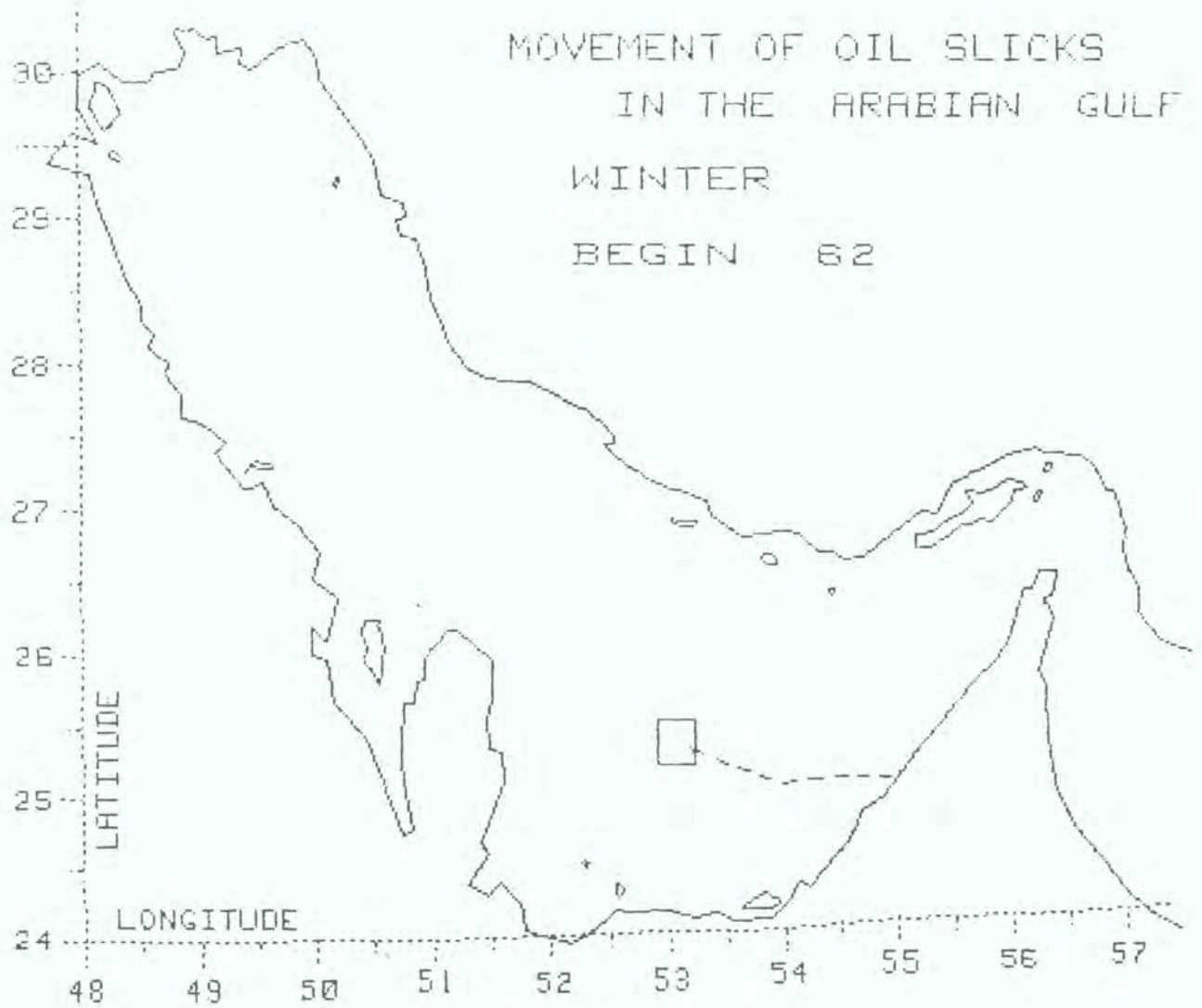

Figure II: The trajectory of an oil spill starting from square 62 in winter

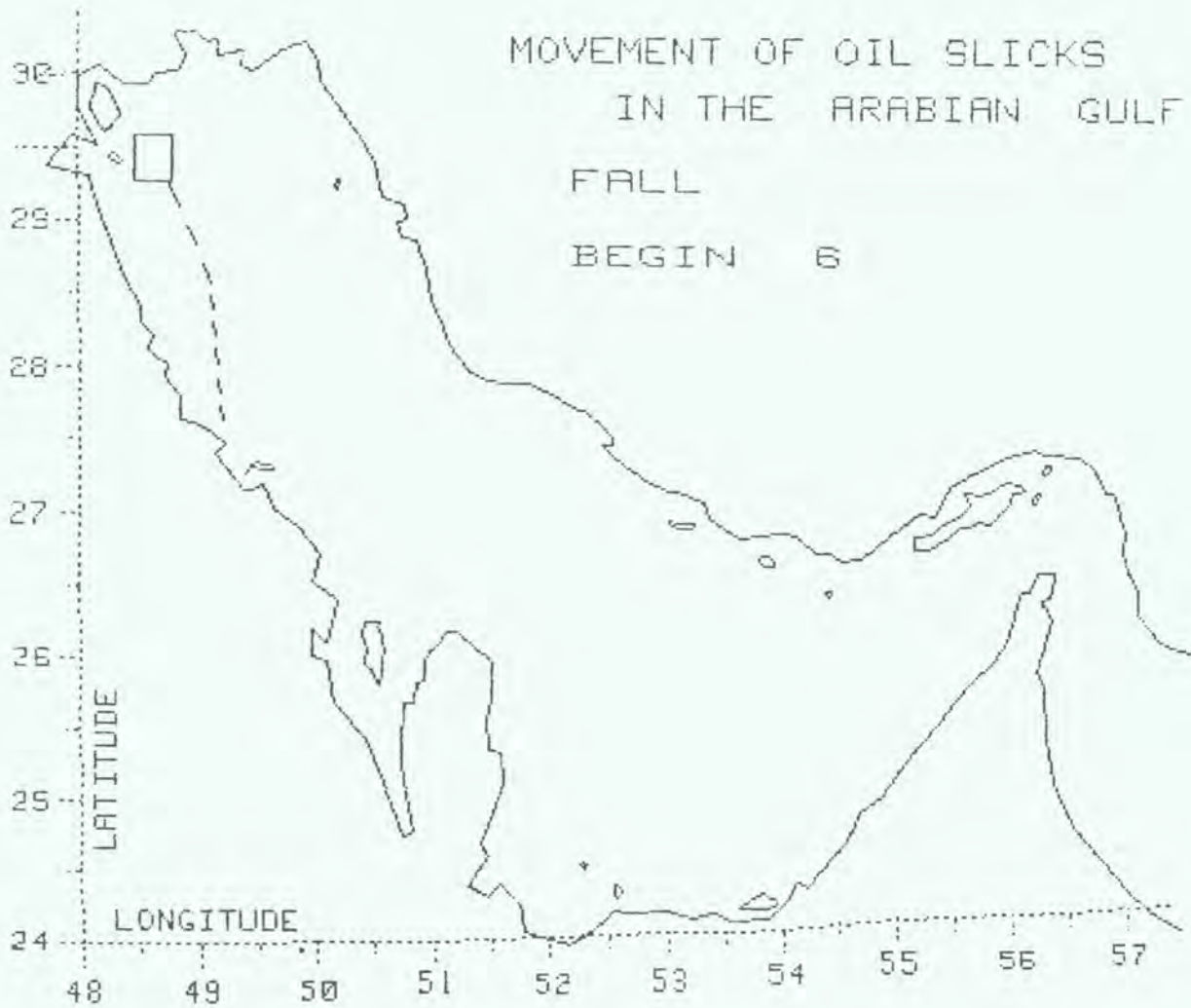

Figure III: The trajectory of an oil spill starting from square 6 in fall

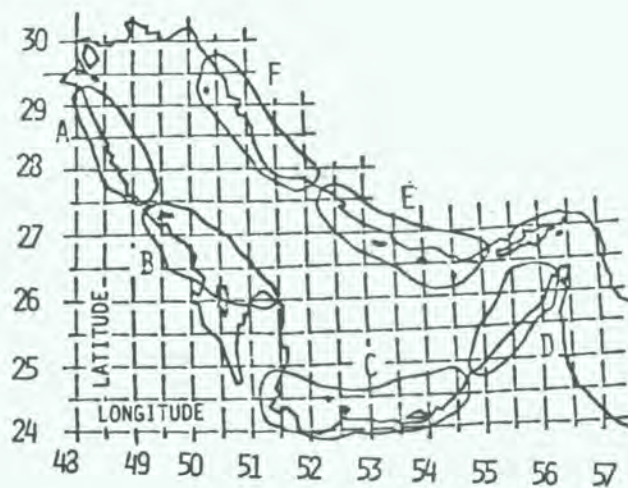

Figure IV: The coastal areas

REFERENCES

- Inter-Governmental Maritime Consultative Organization (IMCO) (1977) Coastal Oil Pollution Evaluation Study for the Kingdom of Saudi Arabia.
- Tetra Tech, Marine and Atmospheric Surveys. Royal Commission for Jubail and Yanbu Contract No. 001-C04.
- STOKES G. (1847) Trans. Cambridge Phil. Soc., 8 and Supplement, Sci. Papers, 1.
- ALOFFS D. and REISBERG R. (1972) J. Phys. Oceanogr. 2: 439.
- RATH R. and FRANCIS B. (1977) Modeling methods for predicting oil Spills Movement. Report to the Oceanographic Commission of Washington.
- LISSAUER I. and BACON J. (1975) Predicted oil slick movement from various locations off the New Jersey-Delaware coastline. U.S. Coast Guard Research and Development Center.
- SCHWARTZBERG H. (1971) Proceedings Joint Conference on Prevention and Control of Oil Spills, p.439.

COMPUTER SIMULATION OF OIL SPILLS  
STATE OF THE ART REGARDING MODELS  
AND APPLIED TECHNIQUES

by  
F. Krogh

Det Norske Veritas,  
Hoevik, Norway

ABSTRACT

Oil spill models can be effective in predicting the fate of oil spills and their impact on the environment provided adequate input information is available.

But still some of the basic processes describing the fate of the oil lack proper analytic description, such as spreading, sub-sea transport, emulsification and dispersion.

The models should be easy to implement, update and use, and be able to accept input from various sources. The output should be presented in a simple and understandable way, e.g. colour graphics (SILKFORCAST/OILSIM).

## INTRODUCTION

The development of offshore oil production and transport facilities has justifiably been accompanied by concern over the possibility of oil spills and the associated potential for adverse impacts upon sensitive off- and onshore areas. Regulatory frameworks have been established for the purpose of balancing the risks of such damage against the benefits of the proposed developments. Decisions within these frameworks must be based upon predictive analyses of the fate of oil that are adequate for risk assessment. In addition, when an oil spill occurs, protective measures to minimize impacts likewise require a capability to forecast the short-term and long-term behaviour of the spilled oil (figure I).

The major factors to be considered when analysing an oil spill are:

- location, size and physical and chemical properties of the spilled oil;
- the transport of the oil by wind and currents;
- the physical, biological and chemical transformations that the oil undergoes.

The general problem of predicting the behaviour of spilled oil is complicated by the wide variety of conditions that may be present, and the stochastic nature of important environmental factors influencing the oil slick. In addition, there is a significant lack of data on many of the most important aspects of oil behaviour.

The past several years have seen a significant increase in the number of computer-based oil spill models, and there continues to be a great deal of effort directed towards generating "new" models. However, there is little actual progress currently being made in the numerical modelling of oil spills. The many models existing and the continuing efforts appear to be primarily variations on one another, with little or no new understanding of the underlying processes. This is not to say that oil spill models are not useful, but rather to say that at present more fundamental knowledge of the behaviour of oil spills is required to realize significant improvements in model formulations.

As for oil spill models, there is a need to delineate the hierarchy of modelling levels that may be achieved on the basis of assumptions of increasing sophistication. In addition to providing a yardstick with which to measure existing modelling efforts, such a review also provides an evaluation of the current needs for additional basic research and data collection.

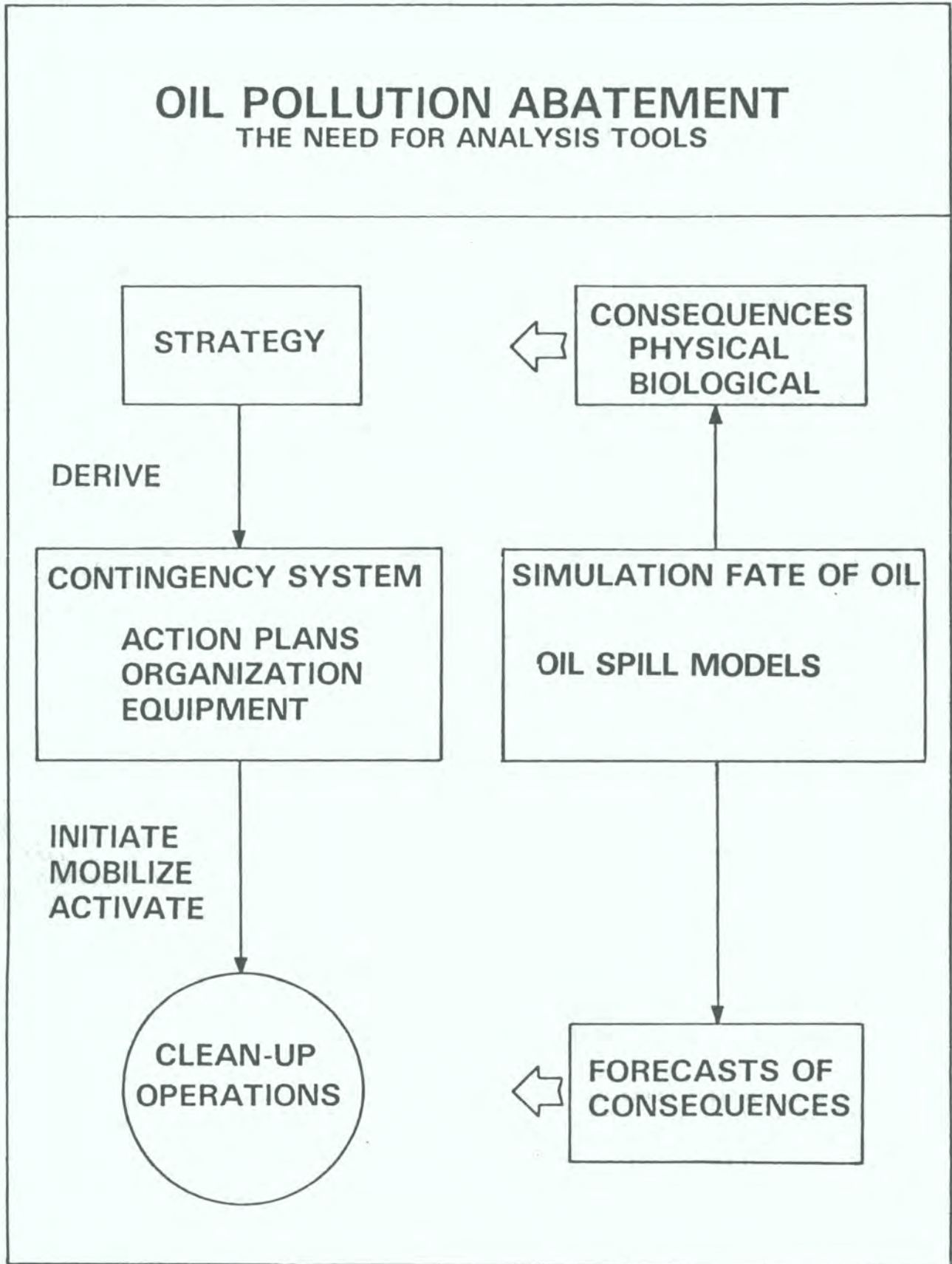

Figure I



## FATE OF OIL

Before looking at the different existing models, a short description is given of the different main factors affecting the fate of the oil (figure II).

- Oil properties : - surface tension
  - specific gravity
  - temperature
  - oil components
  
- Spreading(\*)
  
- Advection : - waves (\*)
  - wind (\*)
  - currents(\*)
  
- Weathering(\*) : - evaporation
  - dispersion (vertical)
  - emulsification
  - biodegradation
  - oxidation
  - sinking/sedimentation

Of these, only the most important factors marked with an asterisk (\*) will be discussed below.

### Wind

Surface winds play an important role in the transport of oil on water. It is common to assume a wind drift factor as a percentage of the wind speed 10 m above the sea surface and a constant deflection angle. Figure III gives some estimated wind drift factors and deflection angles. As can be seen, the wind factors are in the same order of magnitude, and this approach is used in most of the models (3 per cent and deflection angle depending on geographical location).

However, the wind drift factor approach represents a simplification of a very complex process, although variations in percentage drift up to at least 1 per cent are negated by the uncertainties in spill size alone.

In addition to setting up surface currents, the wind also generates surface waves and thus influences the dispersion and weathering (especially evaporation) of the slick.

The wind used in oil spill models may be:

- measured time series/forecasts
- time series using pressure fields
- time series generated using statistics (Markov approach)

Coastal regions are often complicated by mesoscale motions due to thermal and orographic effects. The most common of these are land/sea breeze systems caused by diurnal variations in atmospheric heating and cooling rates over land and water.

Most oil slick transport models use the first approach because it involves wind measurements directly and is thus more appropriate for probabilistic assessments.

# FATE OF OIL ON WATER

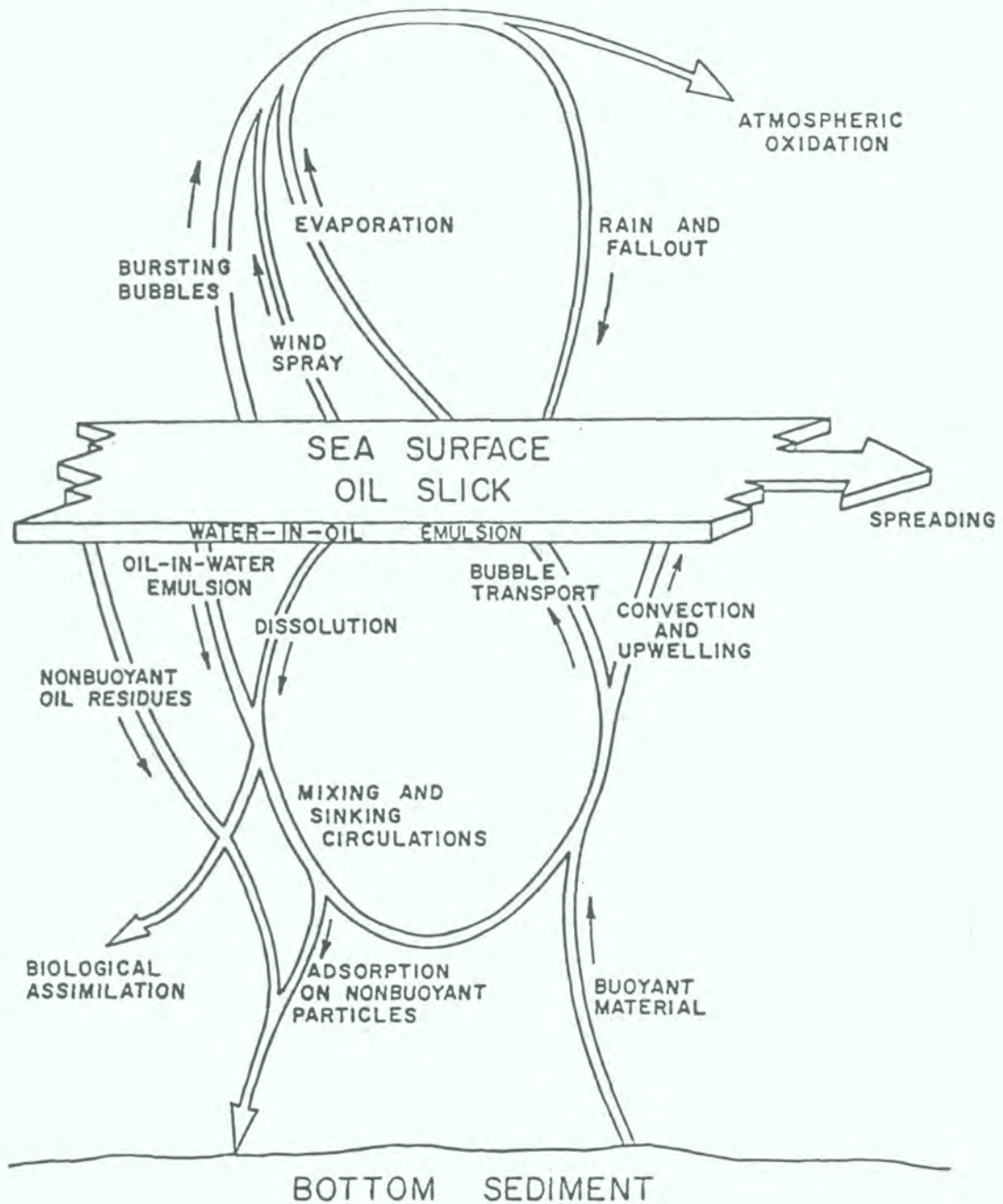

(GARRETT, 1972)

Figure II

## SUMMARY OF VARIOUS EXPERIMENTS INVESTIGATING THE EFFECT OF WIND SURFACE DRIFT

NAME	NATURE OF EXPERIMENT	MEAN WIND FACTOR	DEFLECTION ANGLE (CORIOLIS)
KEULEGAN (1951)	LAB.EXP. (OIL)	3.3	N.A.
VAN DORN (1953)	FIELD EXP. (OIL)	3.3	N.A.
HUGHS (1956)	FIELD EXP. (CARDS)	3.3	3.5 RIGHT
HUGHS (1956)	FIELD EXP. (CARDS)	2.2	0.3 LEFT
TOMCZAK (1964)	HINDCASTING (OIL)	4.3	0.0
TOMCZAK (1964)	FIELD EXP. (CARDS)	4.2	N.A.
NEUMANN (1966)	FIELD EXP. (CARDS)	4.2	0.0.
DOEBLER (1966)	FIELD EXP.	1.6	5.2 RIGHT
DOEBLER (1966)	DRIFTING CURRENT POLE	1.2	13.2 RIGHT
DOEBLER (1966)	DRIFTING CURRENT POLE	4.3	1.9 RIGHT
DOEBLER (1966)	DRIFTING CURRENT POLE	5.8	4.8 RIGHT
BRUSSON (1967)	FIELD EXP. (OIL)	2.5	N.A.
SMITH (1968)	HINDCASTING (OIL)	3.4	3.3 RIGHT
WU (1968)	LAB. EXP. (OIL)	4.1	N.A.
HAUG (1970)	HINDCASTING (OIL)	2.7	N.A.
TEESON (1970)	FIELD EXP. (CARDS)	2.8	13 RIGHT
BRIAN (1971)	LAB. EXP. (OIL)	2.7	N.A.
SCHWARZENBERG (1971)	LAB. EXP. (OIL)	3.7	N.A.
HILL (1971)	FIELD EXP. (DRIFTER)	3.4	N.A.
SMITH (1974)	FIELD EXP. (OIL)	0.8	0.0.
WU (1975)	LAB. EXP. (OIL)	3.5	N.A.
LISSAUER (1978)	FIELD EXP. (OIL)	3.5	N.A.
<b>SPILL OBSERVATIONS</b>			
TORY CANYON		3.4	
GERD MERSEK		4.3	
BRAVO		2.7	

Figure III

The disadvantages of this approach include uncertainty regarding the extrapolation of winds from measuring stations and the difficulty in modelling spatial variability. Use of pressure fields can provide spatial detail in areas of sparse measurements and has advantages for forecasting purposes, since pressure maps are routinely output by numerical weather prediction. However, the approach depends on a correlation between local and synoptic scale motion and may be inaccurate in regions of sea breeze influence or during periods of rapid weather change.

Although oil slick models frequently require wind data to be input in space and time, spatially varying wind fields are seldom used or they are in a simple manner (e.g., by using a weighted average of onshore and offshore observations). The consequences of this representation are most severe in the coastal region extending about 30 km offshore where extremely differing winds may be present over a short distance. Farther offshore, time variations are more important than spatial variations and the assumption of spatially uniform winds is probably adequate.

#### Waves

No adequate analytical model exists for the prediction of oil slick advection by waves.

Our present lack of ability to describe the oil slick advection by waves alone, not to mention the combined effect of waves and a wind-induced shear current, leaves us with only one rational approach. This approach is to deal with the advection of oil slicks as being due to two "separate" mechanisms: (1) advection by waves, (2) advection by currents. As for the advection by waves alone, the use of Stokes' drift velocity seems to have limited experimental support and could for that matter be used to obtain approximate answers. This approach leaves us with the problem of determining the proportion of the surface wind shear stress which is supported by the wave-induced mass transport. However, the wave-induced mass transport may support a portion, possibly a large portion, of the surface wind shear. If this is the case, a separate treatment of the advection by wave-induced mass transport and wind-induced currents should account for this partition of the surface shear stress between a component supported by the waves and the remaining surface shear stress which will induce the wind-driven current. At present this is poorly understood and an improved understanding of it is an absolute necessity if a realistic and accurate model of oil slick trajectories, accounting for both the effect of waves and currents, is to be developed.

#### Currents

Excluding the wind-induced surface current, two other types of currents will influence the transport of spilled oil:

- residual current
- tidal current

The residual currents are usually taken from maps or actually measured (using, for instance, drift cards, buoys, etc.). For a given area, the residual currents may vary with the season, and therefore it is necessary to change residual current maps according to the time of the year. For instance, for the North Sea eight different residual current maps are used.

Tidal currents are taken from maps, measured, or calculated using an analytical model which, given the appropriate boundary conditions, produce very good estimates.

It should be noted that tidal currents, being periodic, will generally give rise to only small net advectations over several tidal cycles, so a detailed knowledge

of these currents does not seem vital for oil spills far offshore. However, this must be judged from spill to spill.

During recent years, three-dimensional models have been developed to calculate surface currents. Although such models will give a more adequate representation of the currents, they are usually very large models requiring numerous input data, and cannot easily be used in an emergency situation.

### Spreading

Real open-sea slicks rarely fit the assumptions made in formulating spreading and dispersion models. This is largely because (1) oil is a complex mixture of hydrocarbons with properties that change as the constituents of the mixture change and (2) actual slick configurations rarely match the idealized geometry assumed by the analytical approaches.

The different oil components, for instance, may not spread at the same rate. Hence, the assumption that the oil can be treated as a single component, with properties and concentrations that do not vary horizontally, is not generally valid. It is also observed that certain surface active components would spread much faster than the rest of the oil. The result of this is that oil tends to divide into thick clumps of more viscous hydrocarbons and wider, thinner patches of faster spreading components. Eventually the oil breaks up into discrete blobs which can be advected independently.

Open sea slicks are rarely round but are distorted by wind and currents into irregular shapes. This also makes it extremely difficult to compare the predictions of radial spreading models with field data. When this comparison is made, the results are mixed. Field data from Conomos (1975) show that Fay's theory greatly underestimates slick growth. Murray (1972) also found that Fay's theory (figure IV) underestimates the growth of a slick, probably because it neglects dispersion due to random water motions. These neglects become more serious as the slick grows larger. Blokker's model has been fitted to several sets of spreading observations, but the constants used differ widely for the different cases.

It has also been shown that, at any particular time, a spreading slick may contain a number of different stages or regions of spreading where different driving and resisting forces act.

### Weathering

#### (a) Evaporation

Evaporation is the primary means by which oil is removed from the slick during the first few days of its existence. Many laboratory and field studies have been performed and several predictive models developed. These models are based largely on techniques developed previously for water evaporation or petroleum distillation. It is fair to say that the state-of-the-art is more advanced and more quantitative for evaporation modelling than it is for modelling any of the other wearing processes (figure V).

Thus, it is possible to predict fairly accurately how much and which parts of an oil slick will eventually evaporate. Only the lower boiling fractions evaporate to any appreciable degree, so the extent of evaporation depends on the amount of these volatiles in the oil.

# SPREADING

## ● FAY THEORY STATES

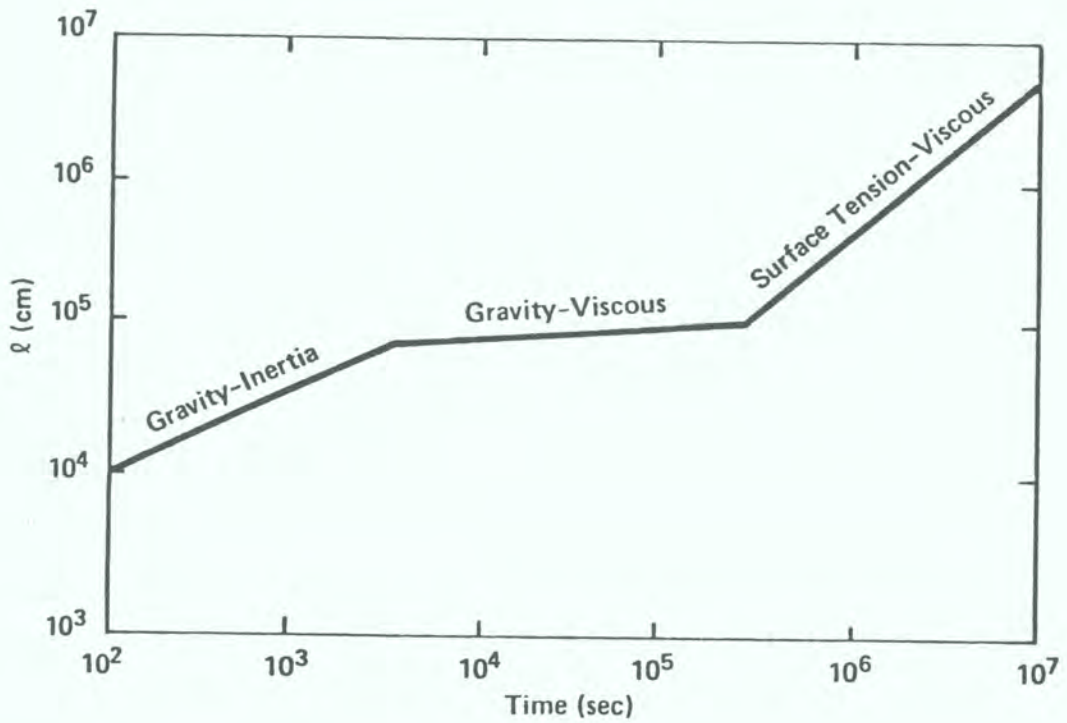

(FAY, 1969)

Figure IV

# EVAPORATION (EKOFISK CRUDE)

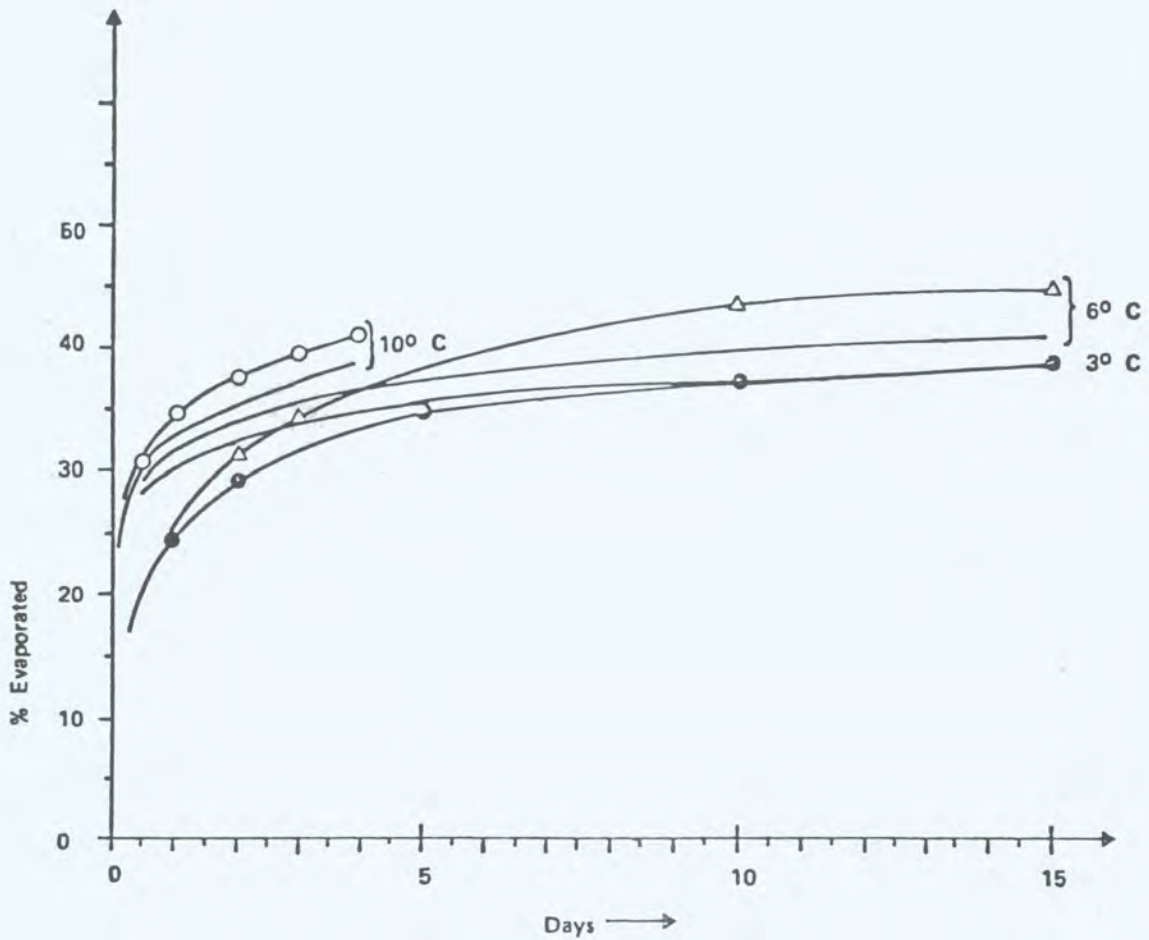

—●— LABORATORY EXPERIMENT  
—△— BRAVO OBSERVATIONS  
—○— OBSERVATIONS FROM TROMSØ  
FLAKET (FIELD EXPERIMENT)  
— SIMULATION MODEL

(AUDUNSON ET AL.)

Figure V

It is more difficult to say how fast this evaporation will proceed since this depends on several environmental factors.

Wind speed (Smith and MacIntyre, 1971) and temperature are the most important, although other variables such as solar radiation also have some influence. The newest models make the evaporation dependent upon these factors.

(b) Vertical dispersion

In addition to dissolving, oil may enter the water column as colloidal or suspended particles in amounts greater than can be expected from dissolution. These particles may range in size from less than a micron to larger than a millimetre in diameter.

Sea state (wave height) is the most important environmental parameter governing dispersion.

As for analytical models, usually a first order approach is used, where the dispersive rate parameter is constant or made a function of the wind speed (Audunson, 1977).

Experimental work by McKay *et al.* (1979) suggests that the process of dispersion and emulsion formation are probably competitive processes. They present equations for both water-in-oil emulsion formation and for oil dispersion in water.

The work by Raj (1977) organized existing theory on such parameters as water waves, oil slick hydrodynamics and turbulence into separate concise models describing wave breaking, oil droplet formation and dispersion and related aspects of the problem.

It is anticipated that shortly, due to ongoing research and measurement programmes, data will be available for input to the proposed models.

(c) Emulsification

The formation of water-in-oil emulsion is one of the most important processes affecting a surface slick, yet one of the least understood. It can be considered to represent a positive flux, in which a new component, water, enters the slick. The volume of this flux may be large enough to outweigh all the negative fluxes associated with evaporation, dissolution and other weathering processes. Smith (1968), for instance, found that the volume of emulsified oil contaminating one beach after the Torrey Canyon spill was larger than the initial spill volume. Water-in-oil emulsions may contain between 10 and 80 per cent water and, as opposed to oil-in-water emulsions involved in mechanical dispersion of oil, they are very stable. Many crude oils, in fact, are initially produced as an emulsion and then dewatered.

Emulsification can change slick-spreading properties more suddenly and more drastically than even evaporation. The viscosity of an emulsion may be 2 orders of magnitude or more higher than that of the oil alone (Atlantic Ocean Lab, 1970). Emulsions spread far more slowly than pure oil slicks and, as a result, are less susceptible to other forms of weathering. The higher the water content the greater these effects. When the water content rises above 50 per cent, the emulsion takes on a semi-solid, grease-like consistency which has been nicknamed "chocolate mousse".

No existing slick models take emulsification adequately into account. To do so



requires an ability to predict when a slick will emulsify and what the water content will be, which in turn requires understanding the mechanisms of emulsification. The state-of-the-art is just reaching this latter point.

As for the kinetics, emulsification has been found to occur from shortly after the spill to three days after the spill (Atlantic Ocean Lab, 1979). Hence it can be grouped with evaporation and dissolution as an early weathering process.

(d) Biodegradation

In the long run, biodegradation is an exceedingly important process in the removal of oil from the marine environment. It eventually takes care of most of the oil that remains after evaporation, dissolution and other quicker processes have run their course. However, the rate of biodegradation is so slow that the process will often not be important for modelling purposes.

(e) Photochemical oxidation

In the presence of sunlight, components of oil can undergo oxidation to form a variety of products. Since these products are often more soluble than the original hydrocarbons, photo-oxidation tends to reduce the volume of the slick through solution.

In the first few days after a spill, photo-oxidation is negligible compared to evaporation and dissolution of the slick's original hydrocarbons. After a week or more, however, the effect of photo-oxidation - on both the quantity of dissolved organics and the spreading properties of the slick - become noticeable.

(f) Sinking and sedimentation

There are several other mechanisms by which oil, either in the slick or dispersed in the water column, may be carried downwards, eventually to the bottom sediments.

The first is gravity-induced sinking, which may occur if the oil density exceeds that of the water. This will happen only for some oils and then only after weathering. An evaporation model and some knowledge of the chemical composition of the oil are usually enough to enable prediction of a slick's tendency to sink.

More interesting is the interaction of oil with sediments. Oil globules can adhere to suspended particles and be carried downwards. Alternatively, oil already dispersed in the water column can come into contact with bottom sediments and be held there.

(g) Status of present knowledge

From what has been said in the previous sections, figures VI and VII try to show the present state of knowledge (Cornillion *et al.*, 1979) concerning simulated processing terms of coastal and fisheries impacts needs.

"U" represent our understanding of critical processes and our ability to model them.

"I" indicates the perceived relative importance of the process for the particular application.

It is seen that there are still a number of areas to be covered before we have a full understanding of the fate of oil spilled on the sea. But the last two to





three years have seen an increase in the research in these areas, and results from this research may improve our understanding considerably in the near future.

## OIL SPILL MODELS

The preceding sections have presented the basic environmental processes that are relevant to the behaviour of surface oil slicks.

While essential, this knowledge is not sufficient in itself to deal with the major issue of this review - modelling oil slick behaviour. This is true because, at any given time, an oil slick is affected by many of these individual environmental processes; hence prediction inherently requires a composite model which combines treatments of the wind field, oil slick advection, and oil transformations into a single calculation scheme. In addition to providing a review of current capability, this section is also a useful indicator of the needs for additional basic research to support modelling efforts.

The existing model types may be divided into two main groups, short-term deterministic and long-term probabilistic:

Short-term deterministic models (e.g. OILSIM) aim at following the spilled oil on an hour to hour/day to day basis and incorporate models for the main factors affecting the spill (residual and tidal currents, wind, waves, evaporation, spreading, etc.).

The following applications may be listed for the short-term deterministic model:

### I. Research

Spill dynamics - to gain a better understanding of the importance of the various processes involved in the fate of spilled oil.

### II. Operational

1. Clean-up - to assist the on-scene-co-ordinator in determining the most efficient clean-up strategy.
2. Damage assessment - to estimate the economic, ecological and aesthetic damage resulting from a spill through an accurate hindcast of the spatial and temporal distribution of the spilled oil.
3. Risk analysis - to estimate the economic, ecological and aesthetic risk from a hypothetical spill under a variety of environmental conditions.
4. Detection - to determine the source of an unknown oil spill (running the model backwards).

Long-term probabilistic models (e.g. SLIKTRAK) are analytically more simple. These models aim to estimate the long-term impact of oil spills based on historical data.

Ocean currents are represented deterministically, while wind drift components are treated stochastically. Tidal motions have been incorporated in nearshore and embayment areas where they may be assumed to contribute to advective transport.

Some models incorporate potential offshore impact targets such as spawning areas, fish migration routes, areas of commercial fishing and sensitive onshore areas. Few of these models include weathering algorithms.

As the latter model types are more simple than the first one, only short-term deterministic models will be considered below.

An important operational consideration is the distance between impact and spill site and how this relates through various environmental processes to the time of impact.

Figure VIII indicates these relationships by plotting the important environmental processes on a space-time chart. One need only estimate the distance to the impact points and the advection velocity towards impact. The diagram indicates impact time and the various physical processes of importance for those length and time scales.

#### Review of composite models

In selecting models to be reviewed in this section, the primary criterion was that the model should have been developed for the purpose of predicting total slick behaviour, whether in an on-line or risk assessment mode. Accordingly, techniques that were specifically designed to treat only one aspect of slick behaviour are not discussed. However, a composite model may not necessarily include representation of all the aspects of oil slick behaviour.

This review was by necessity limited to those models for which adequate documentation was available. The level of detail provided by the review of each model generally reflects the detail of the corresponding source of information (figure IX).

#### Comments on composite models

Figures X and XI summarize the methods used by various composite models in dealing with the different physical processes affecting the oil spill movement. From these figures, several interesting observations on the state-of-the-art of composite models are readily apparent.

Models developed in the later years are more complex than the earliest models, and thus include more of the processes determining the fate of the oil, and also various options for some of the processes.

In modelling the wind field, a lack of diversity is evident. Only four models CG(Bight), USCG, HESS/KERR and DILSIM - are not dependent only upon measured or simulated wind velocities, but may use pressure field data as input.

# TIME LENGTH SCALES FOR OIL SPILLS OF VARIOUS DISTANCES FROM SHORE

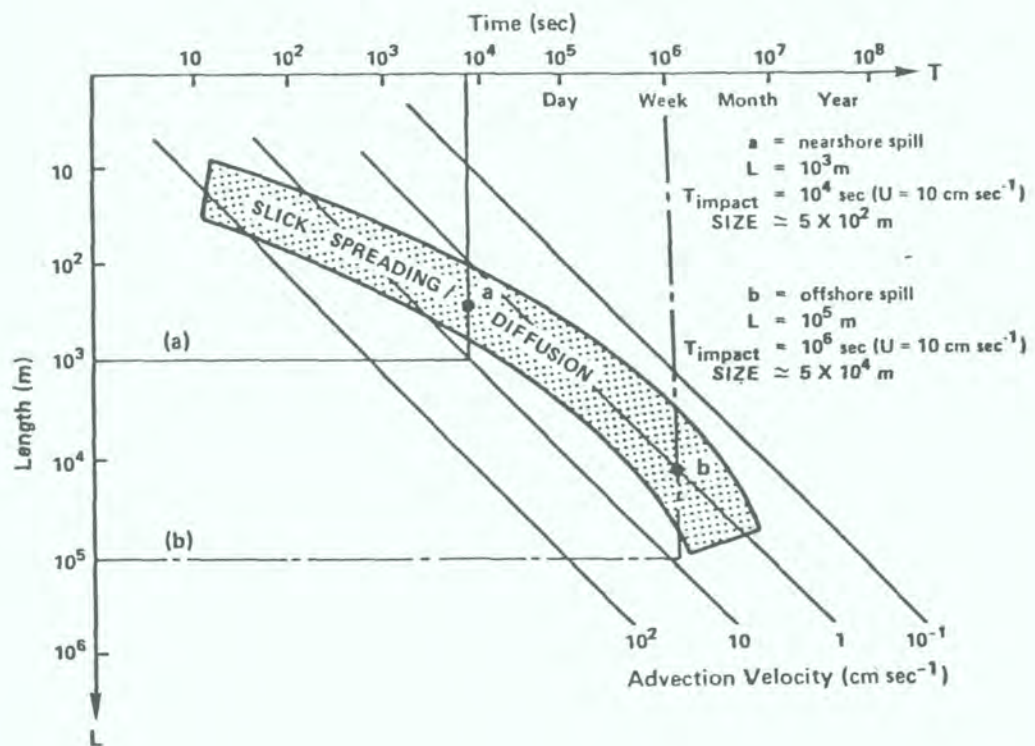

(STOLZENBACH, 1977)

Figure VIII

## COMPOSITE MODELS (SHORT TERM)

● NAVY MODEL	1970
● WGD MODEL	1972
● NARRAGANSETT BY MODEL	1973
● TETRA TECH MODEL	1974
● CEQ MODEL	1974
● CG (N.Y. HARBOUR) MODEL	1974
● SEADOCK MODEL	1975
● CG (N.Y. BIGHT) MODEL	1975
● DELWARE MODEL	1975
● BOSM MODEL	1975
● DPPO MODEL	1976
● API MODEL	1977
● TAMU MODEL	1978
● DRIFT MODEL	1979
● CANADIAN MODEL	1979
● GEORGES BANK MODEL	1979
● HESS/KERR MODEL	1979
● USCG MODEL	1979
● NORDCO MODEL	1979
● OSSM	1979
● OILSIM MODEL	1980

Figure IX

## COMPOSITE MODELS SUMMARY

Webb et al.	1970
Warner et al.	1972
Premack and Brown	1973
Wang and Hwang	1974
Stewart et al.	1974
Lissauer	1974
William et al.	1975
Miller et al.	1975
Wang et al.	1975
Ahlstroem et al.	1975
NOAA	1976
Am. Petr. Inst.	1977
Williams and Hann	1978
Univ. of North Wales	1979
Venkatish et al.	1979
Cornellion et al.	1979
Hess and Kerr	1979
Lissauer et al.	1979
Nordco Ltd.	1979
Torgrimsen and Gall	1979
Krogh and Haldorsen	1980

Figure IX (cont'd)



# COMPOSITE MODELS SUMMARY

ENVIRONMENTAL PROCESS	WIND FIELD		ADVECTION					W A V E S
	M E A S U R E D	S I M U L A T E D	C A L C U L A T E D	LOCAL WIND DRIFT	RESI- DUAL CUR- RENTS		TIDAL CUR- RENTS	
				W F I A N C D T E O R	M E A S U R E D M A P S	O T H E R	M E A S U R E D M A P S	
NAVY	X			X	X		X	
WGD	X				X			
NARR. BAY	X				X	(total)		
TETRA TECH.	X			X	X			
CEQ	X	X		X			X	
CG (HARBOR)	X			X	X		X	
SEADOCK	X	X		X	X			
CG (BIGHT)			X		X	(total)		
DELOWARE	X	X			X		X	X
BOSM	X	X		X	X	X	X	
DPPO	X			X	X			
API	STATE OF THE ART FOR ABOVE MODELS							
TAMU	X	X		X	X			
DRIFT	X			X	X			
CANADIAN	X				X			
GBM	X				X	X	X	
HESS/KERR			X			X		
USCG			X	X		X		
NORDCO	X	X		X	X		X	X
OSSM	X			X	X		X	X
OILSIM	X	X	X	X	X		X	X

Figure X

# COMPOSITE MODELS SUMMARY

ENVIRONMENTAL PROCESS	DIS- PERSION		SPREA- DING		WEATHERING			
	1. O R D E R	O T H E R	F A Y	O T H E R S	EVAPO- RATION		S U B S E A	E M U L S I O N
					L U M P	C O M P O N E N T S		
NAVY WGD NARR. BAY TETRA TECH. CEQ CG (HARBOR) SEADOCK CG (BIGHT) DELAWARE BOSM DPPO API TAMU DRIFT CANADIAN GBM HESS/KERR USCG NORDCO OSSM OILSIM								
			X	X				
		X	X	X				
		X	X		X		X	
	X		X					
	X		X	X				
		X	X	X	X		X	
			X		X		X	
		X	X			X		X
		X	X	X			X	
			X	X				
	X		X			X	X	
	X		X			X	X	

Figure XI

Advection is the primary component of each model. Despite the obvious importance of this process, there is also a lack of diversity in the way these models treat advection. All but four models use the wind factor method to model the surface drift:

WGD Model	: Unsteady Ekman formulation
CG/USCG Model	: Vertically average numerical model
NARRAGANSETT BAY Model	: Wind factor is a function of wind speed and latitude.
CANADIAN Model	: The work of Madsen (Vertical eddy viscosity)

Currents of other origins (e.g. tides, residual currents) are typically derived from current charts, tables or measured data. The exceptions to this are:

- use of hydrodynamic models to calculate total currents (CG/USCG, NARRAGANSETT BAY, HESS/KERR).
- use of hydrodynamic models (simplified) to calculate tidal currents alone (DRIFT, OSSM, OILSIM).

Only two models explicitly include the contribution of waves to slick advection:

DELAWARE	- by multiplying the wind factor by a wave factor which varies around 1.0. This factor is based upon laboratory experiments and its maximum value is probably much nearer to 2.
DRIFT	- using surface gravity theory.

Spreading is included in the majority of the models and most of the governing formulae used can ultimately be transferred to those developed by Fay. All models which include spreading utilize the Fay expressions directly except

TETRA TECH	- applies Fay's equations to independent OILSIM subpatches instead of the entire slick.
BOSM	- uses Fay's results to obtain an equivalent diffusion-spreading coefficient.
DRIFT	- Monte Carlo Techniques
HESS/KERR	- 2-dimensional mass and linear momentum equations.

In those models including dispersion it is usually described by:

1. Simple 1. order equations (CG Bight), TAMU, DELAWARE, NORDCO, OILSIM). The constant used in the equation is usually made weather-dependent (wind speed, sea state).
2. Probability Description - Markov, Monte Carlo, random ejection (DRIFT, CANADIAN, GBM).

Most of the later models include evaporation, either considering the oil as one lump or its separate components.

The calculations of subsea concentrations of oil are either made by using a 3-dimensional Probabilistic theory (e.g. TAMU), or a box model which diffuses and advects the oil (e.g. OILSIM).

Only one model includes emulsification (CANADIAN), and it is simply described by 1. order equation where the coefficient is made dependant upon the weather.

It should be stressed that the models should present their results in a clear, concise format, easily understood by a non-scientist. Visual displays, graphs and maps (as from OILSIM) are the best methods of conveying information. The information must be transmitted rapidly during a spill event.

#### GENERAL CONCLUSIONS AND RECOMMENDATIONS

It should be evident that the general state-of-the-art in composite models is still crude. Though many composite models have been formulated, most have shown a lack of significant innovation. It is clear that many basic environmental processes have virtually no analytical description available and hence must be ignored or simplified.

But oil spill modelling is an effective method of predicting the impact of an oil spill on the marine environment provided adequate information is available on the winds and currents in the area. The probability that a specific environmental element will be impacted is the product of the probability that the oil spill will occur times the probability that if it does occur it will reach that specific environmental element. A third factor that should be included in this evaluation is the probability that if impact does occur, the concentration and contact time will be high enough to cause harm to the elements affected. Consideration of the overall impact of potential oil spills should include summation of the effects on all the environmental elements.

Future work concerning oil spill models should be concentrated upon the following tasks:

- a complete model should be easy to implement, update and use. Further, the model should include all important processes, and be able to accept input data from various sources. The output should be presented in a simple and understandable way (graphs, plots, etc.);
- a better understanding of nearshore processes;
- an oil spill user library which identifies and describes available models;
- better estimates of over-the-water wind field;
- the techniques applied should be validated to a greater extent;
- emphasis should be put on better models for spreading, subsea transport, emulsification, use of chemicals (dispersants).

### Spreading

Improved predictions of the area and thickness of an oil spill are needed. This information is of importance for, for instance,

- regarding the possibility of igniting and burning oil on the sea (thickness);
- the feasibility of using mechanical clean-up equipment (thickness);
- the speed of different processes as, for instance, dispersion, dissolution, evaporation, etc. (area).

### Dispersion

The natural dispersion is of importance for estimating the amount of oil

- left on the sea surface and thus the feasibility of using clean-up equipment;
- driven into the sea.

### Subsea Transport

How the oil behaves beneath the sea surface and its concentrations are of importance regarding the biological impact on the environment.

### Emulsification

To be able to have better estimates of the amount of water-in-oil as well as stability, viscosity, adhesivity, etc. This is important for the development and use of clean-up equipment.

Due to the recent large oil spills, a number of research projects have been started. It is to be hoped, as data from both accidental and planned (experimental) spills become available, new insights will be developed in spill dynamics and the predictive capabilities of the models improved accordingly.

REFERENCES

- Ahlstrom, S.W. (1975) A mathematical model for predicting the transport of oil slicks in marine waters. Battelle Pacific Northwest Laboratories, Richland, Washington: 93 pp.
- Alofs, J.D. and Reisbig, R.L. (1972) An experimental evaluation of oil slick movement caused by waves. J. Phys. Oceanogr. 2: 439-443.
- American Petroleum Institute (1977) Fate of Oil in Water Environment, Phase II: A dynamic model of mass balance for released oil, March 1977.
- Audunson, T. et al. (1980) SLIKFORCAST - A multi-purpose oil spill simulation system. SLIKFORCAST - Main report, Det norske Veritas, Hovik, Norway and IKU, Trondheim, Norway.
- Blokker, P.C. (1964) Spreading and evaporation of petroleum products on water. Proc. Fourth Internat. Harbour Conf., Antwerp., Belgium, 1964: pp 911-919.
- Blokker, P.C. (1966) Die Ausbreitung von Öl auf Wasser, (Oil spreading on water). Dt. Gewasserk. Mitt. 10: 112-114.
- Buckmaster, J. (1973) Viscous-gravity spreading of an oil slick, J. Fluid Mech. 59: 431-491.
- Conomos, T.J. (1974) Movement of spilled oil as predicted by estuarine nontidal drift. Limnol. Oceanogr. 20(2): 159-173.
- Cornillon, P.C., Spaulding, M.L. and Hansen, K. (1969) Oil spill treatment strategy modelling for Georges Bank. In Oil on the Sea (ed. D.P. Hault) Plenum Press: pp. 685-692.
- Cornillon, P.C., and Spaulding, M. (1978) An oil spill fates model. U.S. Department of Energy, Division of Environmental Control Technology, Contract No. E(11-1) 4047.
- Cornillon, P.C., Spaulding, M. and Reed, M. (1979) Impact assessment in oil spill modelling. Proceedings of Workshop on the Physical Behavior of Oil in the Marine Environment, Princeton, N.J., May 8-9, 1979: pp. 4.1-4.31.
- Deepwater Ports Project Office (1976) Analysis of the risk of damage to the States of Florida and Louisiana from the LOOP, Inc. proposed Deepwater Port and analysis of the risk of damage to the States of Florida and Texas from the SEADOCK, Inc. proposed Deepwater Port. National Oceanographic and Atmospheric Administration, Dept. of Commerce, March 25.
- Ekman, V.W. (1905) On the influence of the earth's rotation on ocean currents. Ark. Astron. Fys. 2: 1-53.
- Fallah, M.H., and Stark, R.M. (1976) Random drift of an idealized oil patch. J. Ocean Eng.
- Fallah, M.H. and Stark, R.M. (1976) Vertical diffusion of oil at sea. J. Ocean Eng.
- Fallah, M.H. and Stark, R.M. (1975) A probabilistic model for dispersive oil losses beneath oil booms. Civil Eng. Dept., Univ. of Delaware, Tech. Report, May 1975.

- Fannelop, T.K. and Waldman, G.D. (1971) The dynamics of oil slicks or creeping crude. American Inst. of Aeronautics and Astronautics, New York, 1971, paper No. 71-14.
- Fay, J.A. (1969) The spread of oil slicks on a calm sea. In Oil on the Sea (ed. D.P. Hoult), Plenum Press: pp. 53-63.
- Fay, J.A. (1971) Physical processes in the spread of oil on a water surface. American Petroleum Inst., Proceedings of Joint Conference on Prevention and Control of Oil Spills, Washington, D.C. June 15-17, 1971: pp. 463-467.
- Hess, K.W., and Kerr, C.L. (1969) A model to forecast the motion of oil on the sea. In Oil on the Sea, (ed. D.P. Hoult), Plenum Press: pp. 653-665.
- Hunter, J.R., An interactive computer model for oil slick motion. University College of North Wales.
- Krogh, F., Haldorsen, J. and Audunson, T. (1979) OILSIM - a computer program simulating the fate of oilspills. Norwegian Maritime Research, No. 4.
- Lange, P. and Hühnerfuss, H. (1978) Drift response of monomolecular slicks to wave and wind action. J. Phys. Oceanogr. 8(1): 142-150.
- Lassiter, J.B., Powers, R.J. and Devaney, J.W. (1974) The role of mass transport in oil slick weathering. Report to CEQ, MIT Sea Grant report no. 74-20.
- Leinonen, P.J. and MacKay, D. (1973) The multicomponent solubility of hydrocarbons in water. Can. J. Chem. Eng. 51 (April, 1973) 230.
- Lissauer, I.M. and Murphy, D.L. (1979) Oil spill forecasting - where is it going? Proceedings of 1979 Oil Spill Conference, Los Angeles, March 1979: pp. 649-652.
- Lissauer, I.M. (1974) A technique for predicting the movement of oil spills in New York. Coast Guard Research and Development Center, Groton, NTIS No. AD 786 627.
- Lissauer, I.M., Bacon, J.C., and Miller, M.C. (1977) A computer simulation technique for oil spills off the New Jersey - Delaware coastline. Proceedings of 1977 Oil Spill Conference, March 8-10, New Orleans, 1977: pp. 437-440.
- Lissauer, I.M. and Welsh, J.P. (1978) Can oil spill movement be predicted? Symposium in the Wake of Argo Merchant. University of Rhode Island, Center for Ocean Management Studies, Kingston, Rhode Island.
- MacKay, D. and Walkoff, A.W. (1973) Rate of evaporation of low-solubility contaminants from water bodies to atmosphere. Environ. Sci. Technol. 7(7): 611-614.
- MacKay, D. and Leinonen, P.J. (1975) Rate of evaporation of low-solubility contaminants from water bodies to atmosphere. Ibid. 9(13): 1178-1180.
- MacKay, D. and Leinonen, P.J. (1977) Mathematical model of the behaviour of oil spills on water with natural and chemical dispersion. Economic and Technical Review Report, EPS-3-EC-77-19, Environmental Protection Service, Fisheries and Environment, Canada.

- MacKay, D., Burst, Mascarenhae, I.R. and Patersen, S. (1979) Experimental studies of dispersion and emulsion formation from oil slicks. Proceedings of workshop on the Physical Behaviour of Oil in the Marine Environment, Princeton, N.J., May 8-9, 1979: pp. 1.17-1.40.
- MacKay, D., and Matsugu, R.S. (1973) Evaporation rates of liquid hydrocarbon spills on land and water. Can. J. Chem. Eng. 51.
- Madsen, O.S. (1977) Wind driven currents in an infinite homogeneous ocean. J. Phys. Oceanogr.
- Milgram, J.H. (1977) Mass transport of water and floating oil by gravity waves in deep water. Submitted for publication in J. Fluid Mech.
- Miller, M.C., Bacon, J.C. and Lissauer, I.M. (1975) A computer simulation technique for oil spills off the New Jersey-Delaware coastline, Coast Guard Report No. CG-D-171-75 (45 pp.).
- Murray, S.P., Smith, W.G. and Sonu, C.J. (1970) Oceanographic observations and theoretical analysis of oil slicks during the Chevron spill, March 1970. Baton Rouge, Louisiana State University, Coastal Studies Institute, Tech. Rep. No. 87: 101 pp.
- Murty, T.S. and Khandekar, M.L. (1973) Simulation of movement of oil slicks in the strait of Georgia using simple atmosphere and ocean dynamics. Proc. Joint Conf. on Prevention and Control of Oil Spills, API, Washington, D.C.: pp. 541-546.
- Premack, J. and Brown, G.A. (1973) Prediction of oil slick motions in Narragansett Bay. Ibid.: pp. 531-540.
- Raj, P.P.K. (1977) Theoretical study to determine the sea state limit for the survival of oil slicks on the ocean. U.S. Coast Guard Office of Research and Development, Report No. CG-D-90-77, p. 276.
- Reisbig, R.L., Alofs, D.L., et al. (1973) Measurements of oil spill drift caused by the coupled parallel effects of wind and waves. Mémoires Société Royale des Sciences de Liège, 6ème Série, Tome VI: pp 65-75.
- Reisbig, R.L. and Pottinger, J.M. (1973) The simulation of deep water waves for oil drift studies. Proceedings of the Missouri Academy of Science, 1973.
- Scherret, P.K. (1972) Drift velocity measurements of various materials floating on water-ways. Master's Thesis, University of Missouri, Rolla, May 1972.
- Schwartzberg, H.G. (1970) Spreading and movement of oil spills. Water Pollut. Cont. Res. Report. 15080-EPL 04/70, 1970: 21 pp.
- Schwartzberg, H.G. (1971) The movement of oil spills. American Pet. Inst. Proc. Joint Conf. on Prevention and Control of Oil Spills, Washington, D.C., June 15-17, 1971: pp. 489-494.
- Shukla, D.K. and Stark, R.M. (1974) Random movement of oil patches. The Science of the Total Environment, 3: 117-125.



- Slack, J.R. and Wyant, T. (1979) An oil spill risk analysis for the mid-Atlantic outer continental shelf lease area. In United States Department of the Interior Final Environmental Impact Statement Proposed 1979, Outer Continental Shelf Oil and Gas Lease Sale Offshore the Mid-Atlantic States. OCS, Sale No. 49, New York OCS, 1979: pp. 843-915
- Spaulding, M.L. (1976) Numerical modeling of pollutant transport using a Lagrangian Marker Particle Technique. NASA Technical Memorandum TM X - 73930.
- Stewart, R.J., Devaney Jr., J.W. and Briggs, W. (1974) Oil spill trajectory studies for Atlantic Coast and Gulf of Alaska. Report No. MITSG 74-20, Massachusetts Institute of Technology, Cambridge, MA.
- Stewart, R.J. and Mobley, C.D. (1979) A research program to study wave contributions to oil spill dynamics. Proceedings Workshop on the Physical Behavior of Oil in the Marine Environment, Princeton, N.J., May 8-9, 1979: pp. 1.63-1.79.
- Stolzenbach, K.D. et al. (1977) A review and evaluation of basic techniques for predicting the behaviour of surface oil slicks. MIT Sea Grant Program, Report No. MITSG-77-3.
- Tayfun, M.A. and Wang, H. (1973) Monte Carlo simulation of oil slick movements. ASCE WW3: pp. 309-23.
- Taylor, G.I. (1921), Diffusion by continuous movements, Proc. of the London Mathematical Society, Ser. 2, Vol. 20: pp. 196-212.
- Teeson, D., White F.M. and Schenck, H. (1970) Studies of the simulation of drifting oil by polyethylene sheets. Ocean Eng. Pergamon Press 2: 1-11.
- Tomczak, G. (1964) Investigations with drift cards to determine the influence of the wind on surface currents. Oceanogr. 10: 129-139.
- Torggrimson, G.M. and Galt, J.A. (1979) An on-scene spill model for pollutant trajectory simulations. Proceedings of Workshop on the Physical Behaviour of Oil in the Marine Environment, Princeton, N.J., May 8-9, 1979: pp. 3.43-3.66.
- VenKatesh, S., Sahota, H.S. and Rizkalla, A.S. (1979) Prediction of the motions of oil spills in Canadian waters. Proceedings of 1979 Oil Spill Conference, March 19-22, 1979, California: pp. 677-692.
- Waldman, G.A., Johnson, R.A. and Smith, P.C. (1973) The spreading and transport of oil slicks on the ocean in the presence of wind, waves, and currents. Coast Guard Report No. CG-D-17-73, AD-765 926, (70 pp.).
- Wang, H, Campbell, J. and Ditmars J.D. (1975) Computer model of oil movement and spreading in Delaware Bay. Coastal Engineering report No. 5, Dept. of Civil Engineering, U. of Delaware, December.
- Wang, S. (1974) A numerical model for simulation of oil spreading and transport and its application for predicting oil slick movement in bays. Tetra Tech. Report No. TT-P-345-74-1, Feb. 1974.
- Warner, J.L., Graham, J.W. and Dean, R.G. (1972) Prediction of movement of an oil spill on the surface of the water. Offshore Technology Conf., Dallas, Texas, 1972. Paper No. OTC 1550.

- Webb, L.E., Taranto R. and Hashimoto, E. (1970) Operational oil spill drift forecasting. Paper presented at the 7th U.S. Navy Symposium of Military Oceanography, Annapolis, Maryland, May 12-14, 1970: 8 pp.
- Wilkinson, D.L. (1972) Dynamics of contained oil slicks. ASCE, J. Hyd. Div. 98(HY6): pp. 1013-1030
- Wilkinson, D.L. (1973) Limitations to length of contained oil slicks. Ibid. 99(HY5): pp. 701-712.
- Williams, G.N., Hann, R. and James, W.P. (1975) Predicting the fate of oil in the marine environment. Proc. of Joint Conference on Prevention and Control of Oil Spills, Am. Petrol. Institute, Washington, D.C.
- Williams, G.N., and Hann Jr., R.W. Simulation models for oil spill transport and diffusion. College Station, Texas.
- Wu, J. (1973) Prediction of near-surface drift currents from wind velocity. J. Hyd. Div. ASCE 99(HY9): pp. 1291-1302.

A COMPUTER-ASSISTED OIL SPILL CONTINGENCY CENTRE WITH EMPHASIS  
ON DATA BASES, RISK AND CONSEQUENCE ANALYSIS

by  
F. Krogh

Det Norske Veritas,  
Hoevik, Norway

ABSTRACT

The primary objectives in oil pollution control must be to prevent or reduce the probability of oil spills from occurring, and minimize the consequences when they occur.

A major part of the total influx into the oceans is caused by operational spills and these may be substantially reduced by introducing more restrictive regulations and follow-up.

The risk of accidental oil spills, which may represent serious threats to the local areas, may be reduced to an acceptable level through proper standards and quality assurance.

The use of risk analysis may give important information for the definition of proper safety and quality standards as well as identifying areas for improvement of equipment and procedures.

When oil spills occur it is important to be able to mount the proper countermeasures as soon as possible. In addition to conventional combating equipment, an integrated and interactive computer system may be of assistance.

## INTRODUCTION

While the operational spills from offshore and onshore activities account for by far the largest part of oil spilled into the oceans, it is the few, but large and acute, accidental oil spills which are brought to our attention - and rightly so, because these concentrated oil spills represent the most severe threats to local areas.

In addition to collisions and groundings of ships, accidents related to offshore petroleum activities such as blow-outs and the rupture of subsea pipelines have a large pollution potential.

It should be mentioned that while the total number of blow-outs leading to oil spills is fairly small, perhaps in the order of two or three per year on an average, the total number of ship accidents causing oil pollution is substantial. In 1978 as many as 50 ship accidents with spills greater than 60 tonnes were reported.

In our work for safety at sea, we not only focus on safety of life and property, but also on safety of the environment. Some of the key services offered by VERITAS in this respect are:

- Risk analysis of hazardous activities
- Quality assurance of hardware and procedures
- Consequence analyses of oil spills
- Quality assurance of clean-up equipment
- Oil contingency planning and assistance

Of these services, this paper will concentrate upon

- Risk analysis
- Consequence analysis
- Oil spill contingency planning

and also show how computer systems may be of assistance.

The primary objective in oil pollution control must be to prevent or reduce the probability of oil spills occurring. Realizing that spills cannot be completely avoided, the objective must furthermore be to reduce the consequences of oil spills when they occur.

In order to determine the best strategy for coping with an offshore oil spill, it is necessary to know as much as possible about the likely consequences, both physical and biological, under different ambient conditions.

Based on this, the corresponding contingency system including organization, equipment and procedures may be defined.

## OBJECTIVES

The computer-assisted contingency centre should have the following main tasks.

1. Be an information, simulation and forecasting centre in connection with spill situations, serving both the task force, the operators and the Government(s).
2. Be an information and simulation centre for contingency planning in connection with present and planned offshore activities (test drilling, development of oil and gas fields, ship traffic, pipeline operations, transfer of cargos, etc.).
3. Carry out risk analysis of hazardous activities (manoeuvring, collisions, groundings, blow-outs, pipeline ruptures, etc.).

Additional risk analysis includes the combined evaluation of the probability (of oil spill contamination) and the consequences.

## JUSTIFICATION

When a major oil/gas spill occurs, combat actions have to be initiated immediately. A task force is normally set up with the responsibility of organizing the most suitable counter-measures. To do a proper job this task force needs immediate access to be in a position to give information on:

1. the spill source;
2. the combat equipment available, where it is located, efficiency, availability;
3. short-term forecasts of wind, sea state, currents and fate of the oil spill;
4. long-term forecasts of the fate of the spill: Most-exposed sea and shore areas, the amount of oil reaching shore dependent upon the combat actions taken, the size and duration of the spill, the well behaviour (during a blow-out), air and sea temperature, oil quality, etc.;
5. observations of the fate of the spill.

Experience during recent years shows a significant lack of preparedness when a major spill occurs. Valuable time is lost at the start of combat actions and it is very difficult to estimate the influence of the various actions on the ultimate results.

This situation could be drastically changed if an oil/gas spill contingency centre were operative immediately, or at short notice, providing an operational system and all relevant information to the operators, and the Government(s).

This can be achieved only if there is some continuous activity at the centre updating the information bases, the simulation models, etc.

## PROPOSAL FOR A COMPUTER-ASSISTED OIL SPILL CONTINGENCY CENTRE

The Contingency centre should be equipped with a powerful mini-computer, the necessary risk analysis, simulation and data base software.

The computer system should be run interactively both from the centre itself and from regional centres and the spill site, using a dial-up capability with a hard-copy or graphic facility. Also to be considered is a mobile headquarters trailer containing communications and other emergency equipment.

Information is presented on graphic displays and stored on discs, magnetic tapes and/or printed out on a line printer.

Input data is supplied by relevant meteorological/oceanographical offices, the operators, local and national authorities and from observations.

The centre will be responsible for the following activities:

1. Implement and update data bases for
  - a) Personnel to be contacted and related procedures;
  - b) Combating procedures for various types of accidents;
  - c) Locations and specifications of combating equipment (booms, skimmers, boats, etc.);
  - d) Data and maps for sensitive off- and on-shore areas;
  - e) Risk trajectories and analyses;
  - f) Data for the oil and environment.
2. Perform risk-analyses of hazardous activities (collisions, groundings, blow-outs, etc.) to assess the risk levels and to identify improvements of components and procedures (e.g. sea transport) which contribute to improved safety in the most cost-efficient way.
3. Use Computer Simulation programs (for instance OILSIM, SLIKTRAK and SLIKFORCAST) based upon the latest technology to
  - perform analyses of oil spills from potential and present drilling and production sites, pipelines, etc., in advance, using historical data. The results will be of assistance when, for instance, preparing a strategy for oil spill counter-measures and the corresponding contingency plans.
  - have a system ready in a crisis (blow-out, tanker accident, pipeline rupture) for immediate simulation of the fate of the oil, both short-term (OILSIM) and long-term (SLIKTRAK).

SHORT DESCRIPTION OF THE VARIOUS TASKS

Data Bases

(a) Personnel to be contacted

This file contains names, addresses and telephone numbers of persons to be contacted when a spill occurs.

For different types of spills (ships, pipelines, etc.) different categories of people will be contacted and at different levels.

(b) Combating procedures

The system will print out the latest combating plan for the given spill (given amount, location, type of spill, etc.).

Included is an estimated timetable which might look like the following:

Manpower	On-site 2 hours after request
In-Bay Skimmers	Under way 1 hour after request
Ocean Skimmers	Under way 4 hours after request
Suppliers	Sufficient quantity on hand for first 24-hour period.

Further detailed organizational plans, complete job descriptions etc. are included.

(c) Combating equipment

Using the location of the spill as input, the computer will produce a map showing the depots with combating equipment available for this spill.

Inventory lists may be produced together with the required manpower.

Also included are procedures for removing oil from the sea and shorelines.

(d) Sensitive areas

Given the location for the spill, the computer produces maps of the sensitive areas which may be affected. This map must be correlated with the maps for the depots with combating equipment.

(e) Risk trajectories

As described below, the fates of assumed oil spills from high risk regions have been computed in advance using historical data.

Giving the location and time of the year as input, previously calculated trajectories will be shown on the displays. These maps must be correlated with those in (c) and (d).

From these points alone, and with only the location of the spill as input, the first decisions may be taken as to find the best way to fight the oil spill.

(f) Data for the oil and the environment

When more information about the spill becomes available, e.g. type of oil, further relevant information on this oil is fetched from the data base and used as input to the simulation models.

Also activated are files with residual and tidal currents.

The information on the data base is updated regularly and when new information becomes available.

Risk Analysis

An important element in Quality Assurance is to set the proper standards and in addition to check that the standards are met. This is particularly a problem when dealing with large and complicated systems, like an offshore production platform, of which previous experience is limited.

An efficient tool to assist in solving these problems is risk analysis. Such analyses may take many forms, but in general they will comprise the identification of possible hazards and an analysis of their causes and consequences. The analyses may also include an evaluation of means for reducing probabilities and consequences (figure I).

In order to give an indication on how such analysis may be carried out, we will briefly describe the different steps, the necessary inputs and what the output might be from such an analysis.

The analysis follows the general procedure outlined above and the first step is a system description. Essential information is related to ship traffic, offshore pipelines, offshore production and exploration and tanker loading facilities. (See also annex I for further details).

Among the various hazards, unwanted events must be identified and related to different phases of the operation.

For ship-traffic, hazard identification will comprise:

- sailing phases (hazard rating)
- cargo characteristics

and the unwanted events will include:

- spill during cargo transfer
- discharge from ships
- ship accidents (collision, grounding, explosions)

For offshore pipelines, the identification will comprise hazard rating for:

- corrosion (internal, external)
- equipment failure
- operational procedures
- defective pipe seams
- vandalism
- structural defects (seams, welds, repairs)



# GENERAL RISK ANALYSIS PROCEDURE

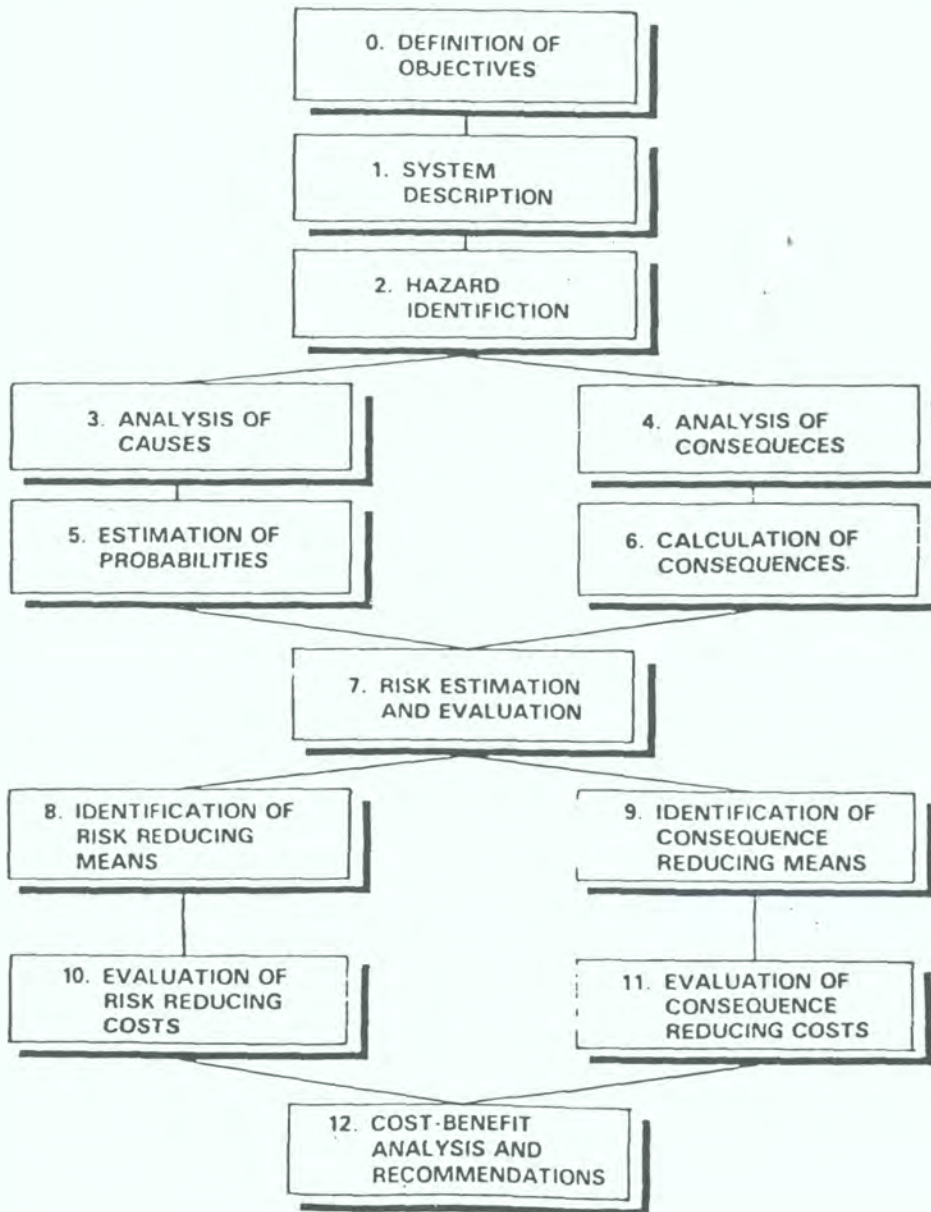

Figure I

and the unwanted events will include:

- fire
- explosion
- rupture

For offshore exploration and production the identification will comprise hazard rating for the operational procedures of:

- drilling
- production
- offshore loading terminals
- type of rigs

and the unwanted events will include:

- blow-outs
- well casing ruptures
- loss of rigs
- fire
- seepage.

In calculating the probability of accidents as well as their location, available statistics (local; statistics for similar areas; world-wide accident statistics) are used combined with theoretical models.

The next step is to calculate the probability that the accident will cause an oil spill and again historical data (frequencies, quantities) on a world-wide basis combined with theoretical models are used.

Figures II-III show as an example some of the results from such an analysis carried out for the Norwegian State Pollution Control Agency. The aim of the project was to assess the risk for oil spills from tankers sailing to and from an oil refinery on the west coast of Norway.

From the material, one may also assess how this probability is distributed on spill size and oil type (figure II) as well as location.

In figure (III) type probability of oil spills is shown. In a 15-year period there is a probability of 0.64 for at least one oil spill over 1 tonne.

Similar studies have been carried out for other oil refineries in Norway giving comparable results. These and other studies have been initiated by the State Pollution Control Agency so that they can establish an overall picture of the environmental risk related to different activities onshore and offshore, as a basis for their future work, including the preparation of laws and regulations.

In a study for the Norwegian Department of Oil and Energy, carried out by VERITAS in co-operation with various institutes in Norway, the purpose was to estimate the risk of blow-outs on the Norwegian Continental Shelf.

Figure IV shows an example of results from this analysis. Also calculated were flow-rates and duration of the spills.

Having carried out risk analyses of this type, one might be able to judge whether the activity has an acceptable safety factor, or to focus on the weak elements in order to find alternative solutions with increased safety.

# OIL SPILL RISK FROM TANKER TRAFFIC TO MONGSTAD REFINERY

## PROBABILITY FOR N SPILLS IN A 15-YEAR PERIOD

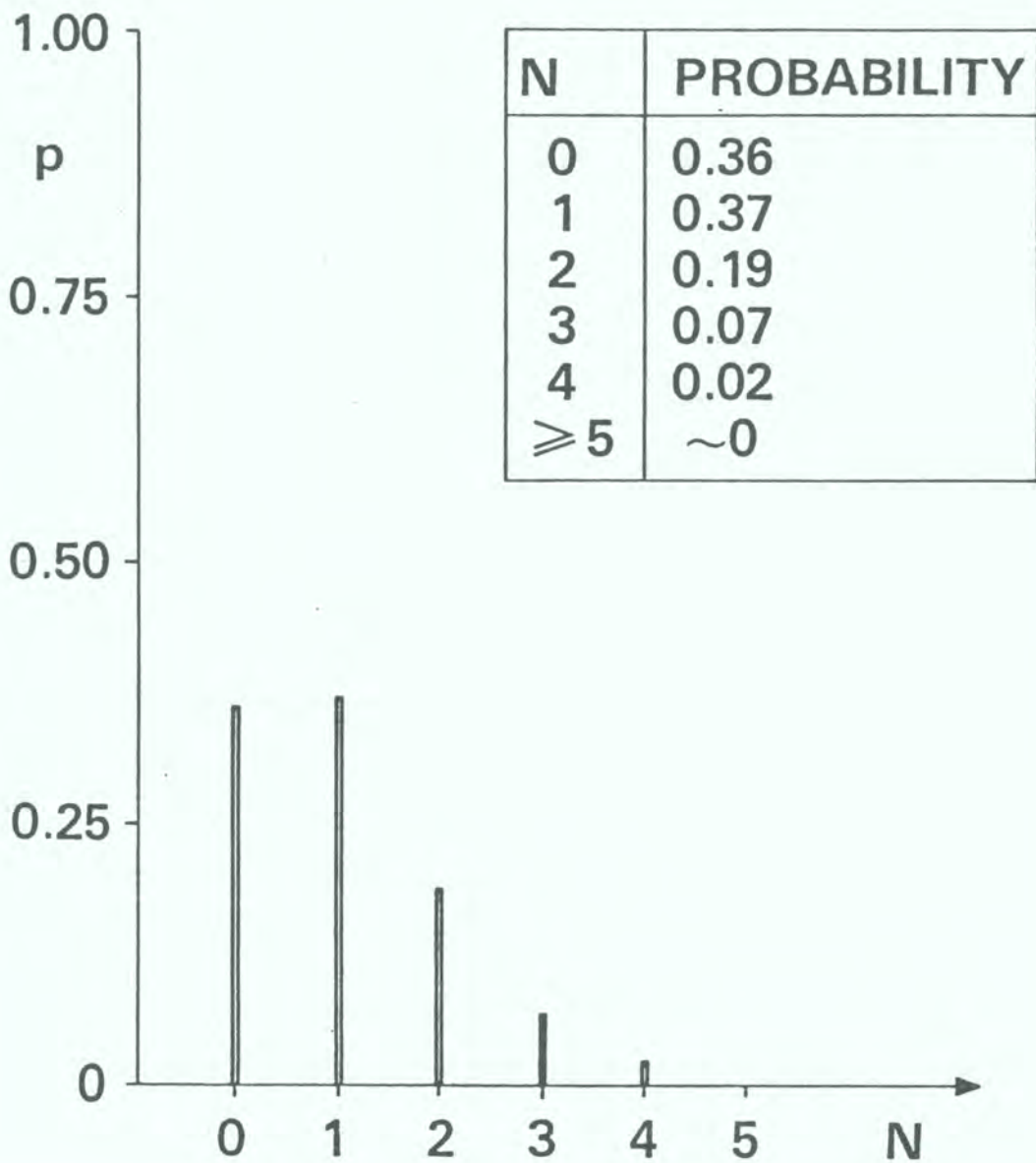

Figure II

## OIL SPILL RISK FROM TANKER TRAFFIC TO MONGSTAD REFINERY

### PROBABILITY FOR AT LEAST ONE SPILL IN A 15-YEAR PERIOD

SPILL SIZE (tons)	PROBABILITY		
	Products	Crude	Total
1 — 10 000	0.55	0.015	0.565
10 000 — 40 000	0.06	0.008	0.068
40 000 — 100 000	0	0.005	0.005
> 100 000	0	0.002	0.002
> 1	0.61	0.03	0.64

Figure III

## OIL SPILL RISK ANALYSIS

### ESTIMATED PROBABILITIES FOR BLOW-OUTS AND THEIR CONSEQUENCES ON THE NORWEGIAN CONTINENTAL SHELF PROVIDED THE ADOPTION OF SOME RISK REDUCING MEASURES

Event	No. of wells per event		No. of production well-years per event
	exploration drilling	production drilling	
Blow-out	> 5 000	> 5 000	> 50 000
Blow-out with oil spill	> 50 000	> 50 000	> 50 000
> 10 000 t	> 500 000	> 50 000	> 50 000
> 100 000 t	—	> 500 000	> 50 000
> 1 000 000 t	—	> 500 000	> 500 000
Fire	> 50 000	> 50 000	> 50 000
Total structural damage	> 50 000	> 500 000	> 500 000

Figure IV

The risk analysis also provides valuable information for the development of rational regulatory requirements and contingency plans related to oil spill prevention and abatement.

#### Risk Reduction/Ship Spills

The measures for protection of the environment against oil pollution may be divided into three main categories (figure V), of which two are aimed at reducing the operational and accidental spill amounts, while the third is aimed at reducing the consequences of spill that have already occurred.

Regarding measures to reduce the operational spills, this is not primarily a question of a risk reduction, but rather a matter of introducing adequate laws and regulations to prohibit such spills (figure VI). Such work is in progress for ship spills and it is likely that when the new IMO requirements laid down in the MARPOL Convention of 1973 and the Protocol of 1978 come into force, probably in mid-1981, these spills should be reduced from 1.8 million tonnes per year to less than 0.5 million tonnes.

Most of the accidental oil spills are still due to ship accidents and particularly to collisions and groundings of oil carriers. Fire and explosions have also caused serious accidents with oil spills. Even without carrying out an in-depth analysis of the individual accidents, it is possible to define a range of general measures for reducing the probability of such accidents as well as the amount of oil released if accidents should occur (figure VII). Both MARPOL 1973 and SOLAS 1974, with protocols from 1978, specify a number of measures concerning arrangement, equipment and operational procedures which will further increase the safety.

Even with the best available technology and operational procedures, we know that accidents cannot be completely avoided. It is therefore necessary to reduce the harmful consequences of actual oil spills and for this purpose an efficient oil spill contingency system is required.

#### Oil Spill Simulation Models

VERITAS has extensive experience with consequence analyses, incorporating the calculation of drift, spreading and weathering of possible oil spills, as for instance, analysis for the Ekofisk, Statfjord, Halten and Tromsø fields on the Norwegian Continental Shelf and the Gorm field in the Danish sector. Furthermore, we have studied the consequences of possible ruptures of the pipelines between Ekofisk and Teesside as well as for a potential pipeline between Statfjord and Sotra.

In those simulation studies the program system SLIKFORCAST was used.

Using historical wind data and results from the risk analysis for high risk areas, simulation studies should be carried out in advance to

- establish risk trajectories for spilled oil
- correlation of results with sensitive areas.

These results are basic information for some of the data bases discussed above.

Some of the probable spill locations may be a short distance offshore, and it is therefore important that the program system is easy to load and run. In

# PREVENTIVE MEASURES

## SHIP SPILLS

MEASURES TO REDUCE OIL SPILL QUANTITIES		MEASURES TO REDUCE THE CONSEQUENCES OF ACUTE OIL SPILLS
FROM OPERATIONAL SPILLS 1,8 MTONS/YEAR	FROM ACCIDENTAL SPILLS 0,3 MTONS/YEAR	

- REDUCE OPERATIONAL SPILLS
- REDUCE ACCIDENTAL SPILLS
- IMPROVE COUNTERMEASURES

Figure V

# REDUCTION OF OPERATIONAL SPILLS

## SHIP SPILLS

- **STRICTER REQUIREMENTS FOR DESIGN AND OPERATION OF SHIPS**  
IMO requirements for oil carriers  
SBT: Segregated Ballast Tanks
- **MORE RECEPTION STATIONS FOR OIL AND SLOP FROM OIL CARRIERS**
- **SURVEILLANCE AND CONTROL OF OPERATIONAL SPILLS**  
Airborne surveillance  
Fingerprinting of oil

POTENTIAL REDUCTIONS (MILL. TONS/YEAR)		
CAUSE	TODAY	TOMORROW
SHIPS WITH LOT	0.3	} 0.2
SHIPS WITHOUT LOT	0.8 = ?	
OTHER SPILLS	0.7	0.3
SUM	1.8	0.5

Figure VI



# REDUCTION OF ACCIDENTAL SPILLS

## SHIP SPILLS

- **STRICTER REQUIREMENTS TO THE DESIGN AND OPERATION OF SHIPS**  
IMO requirements: MARPOL & SOLAS  
Navigational equipment  
Manoeuvring ability  
Strength against collision/grounding  
Tankarrangement  
Explosion hazard
  
- **SAFER FAIRWAYS**  
Traffic separation, speed  
Traffic surveillance  
Piloting
  
- **IMPROVED CONDITIONS FOR THE NAVIGATORS**

Figure VII

addition, the short-term program (OILSIM) may be run interactively, i.e. the user may communicate with the program and, for instance, change data input when appropriate.

(a) Development of Slikforecast

Late in 1976, Det norske VERITAS and The Continental Shelf Institute of Norway (IKU) started the development of OILSIM, a computer program for the analysis of the physical fate of oil spills at sea. It was a deterministic program calculating a detailed time-history of a single oil spill under given or assumed ambient conditions. It was furthermore made interactive so that the operator could easily communicate with the computer model during the simulation, for instance to change the input weather data. A preliminary version was ready in April 1977 and was used during the Bravo blow-out in the North Sea in the same month. It has later been further improved and applied to a wide range of consequence analyses of potential oil spill situations.

SLIKTRAK, which has been developed by Shell International Maatschappij, is a probabilistic model in the sense that it applies statistical weather data to generate a large number of possible oil spill trajectories for each spill source. Thus it presents a probabilistic picture map of the likely drift pattern of an oil spill. It is thus particularly suited to carry out consequence analysis in advance, rather than analysing actual spills.

In 1979, co-operation was initiated between VERITAS, IKU and the E&P Forum of the oil companies for a further development of OILSIM and SLIKTRAK into a combined program package named SLIKFORCAST. The programs basically use the same physical model and have been adapted to accept the same format of weather data, thus simplifying the generation and storing of these. The package also includes a program module NEPTUN-C21 for the calculation of tidal currents for the actual area. The general layout of the SLIKFORCAST package is illustrated in figure VIII a and b.

(b) SLIKFORCAST - option

A unique feature of the SLIKFORCAST model is the possibility of transferring simulation results from the deterministic model to the stochastic model. This makes possible statistical forecasts of the probable fate of oil spills during a given emergency situation. The forecast estimates are based upon historical weather and current data, given blow-out rate and location, estimated ranges for continued blow-out duration and the deterministic results up to and including the latest deterministic forecasts. As time moves on, the stochastic or probabilistic forecasts can be updated starting each time from the latest deterministic results (figure IX a and b).

The appropriate wind data must be taken from the historical weather data file for the time window corresponding to the given oil spill situation. One of the important features of the SLIKFORCAST model is that, as more and more information is gained about the specific spill situation, the uncertainty range in the estimates gradually decreases.

# MAIN ELEMENTS OF SLIKFORCAST

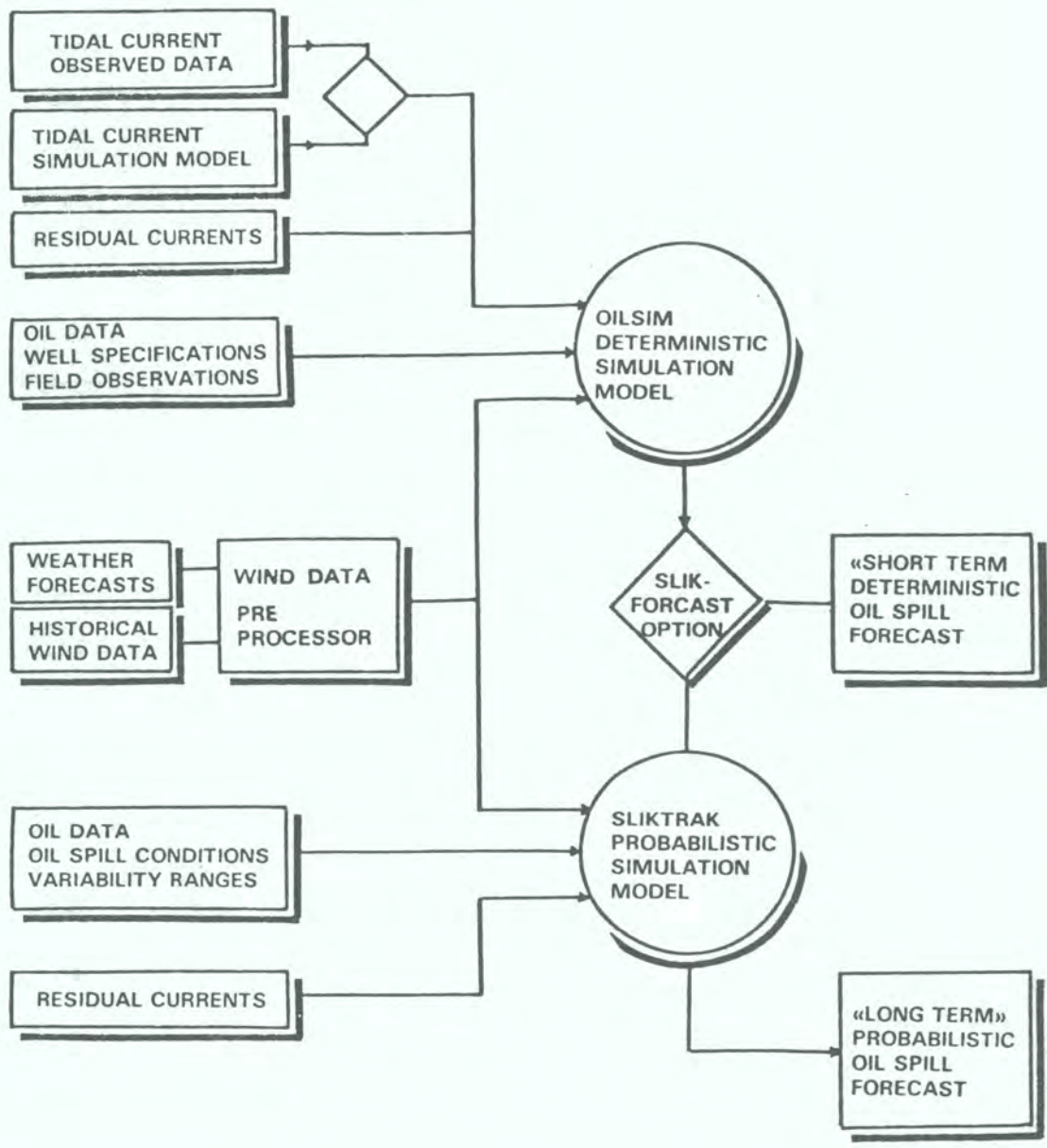

Figure VIIIa

# DATA TRANSFER OILSIM — SLIKTRAK

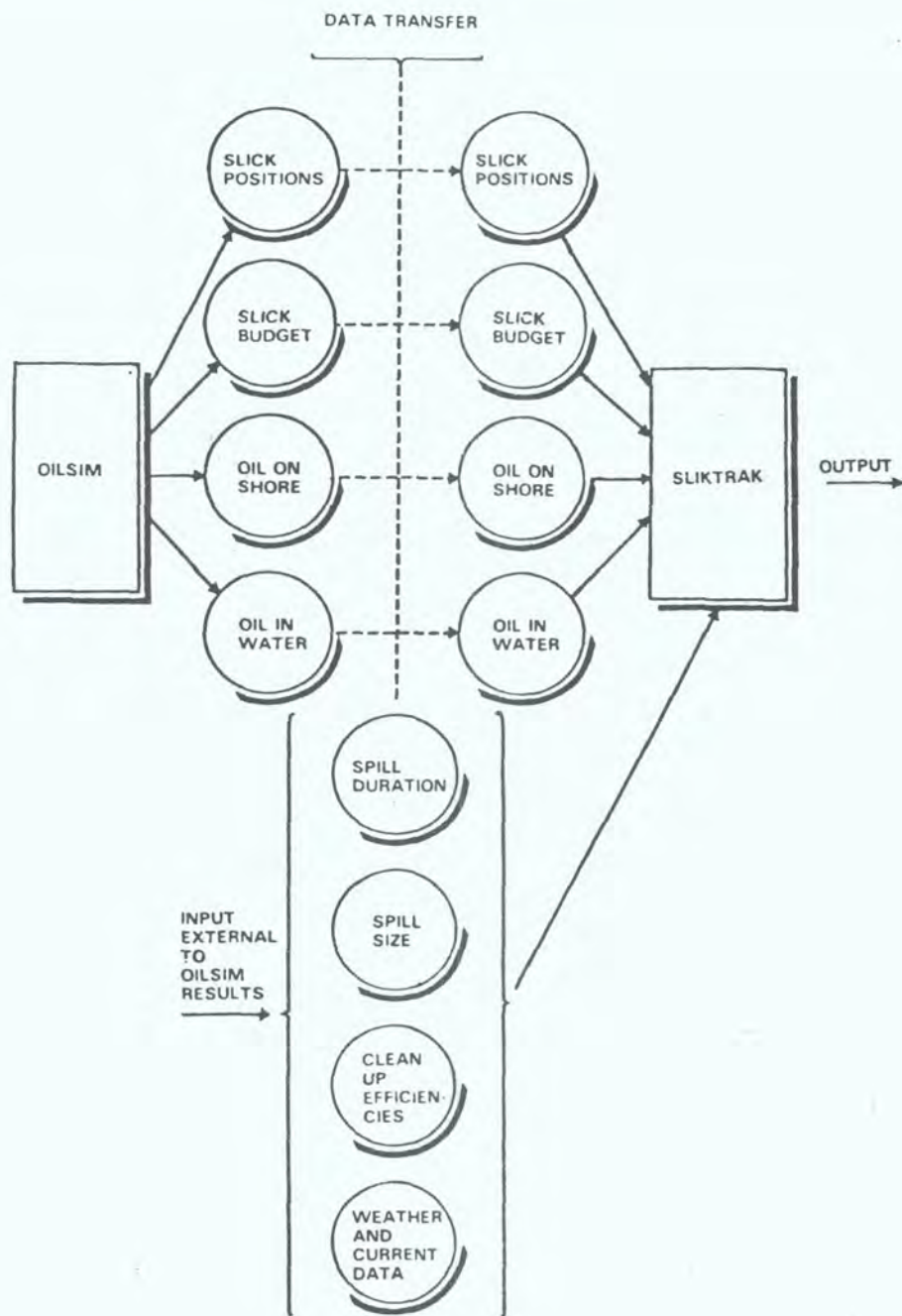

Figure VIIIb

## OUTPUT FROM OILSIM

### OILSIM

DETERMINISTIC MODEL  
DETAILED ANALYSIS FOR  
GIVEN AMBIENT DATA

FOR EACH TIMESTEP IN A SIMULATION:

- PRESENT POSITION OF OIL
- PRESENT AMOUNT OF OIL ON SURFACE
  
- ACCUMULATED AMOUNT OF OIL ON SHORE
- ACCUMULATED AMOUNT DISPERSED & EVAP.
- ACCUMULATED AMOUNT COLLECTED
- ACCUMULATED RESIDENCE TIME AT GRIDPOINTS
- ACCUMULATED AREA AFFECTED BY OIL
  
- DRIFT TIMES TO SHORE LOCATIONS

Figure IXa

## OUTPUT FROM SLIKTRAK

**SLIKTRAK**  
STOCHASTIC MODEL  
STATISTICAL ANALYSIS OF  
LIKELY CONSEQUENCES

FOR EACH COMPLETE SIMULATION:  
MINIMUM, MAXIMUM, AVERAGE

- AMOUNT OF OIL ON SHORE
- AMOUNT OF OIL DISPERSED
- AMOUNT OF OIL COLLECTED
- DRIFT TIMES TO SHORE
- RATE OF OIL SHORING
- DRIFT TIMES TO CRITICAL SEA AREAS
- OIL CONCENTRATIONS IN CRITICAL AREAS
  
- SPILL TRAJECTORY PLOT
- POLLUTION COST ESTIMATE

Figure IXb

(c) Operational aspects

When a spill occurs, the basic data will already be in the computer, and the additional input will be

- (i) position of spill
- (ii) spill rate (best estimate)
- (iii) present time
- (iv) present and forecasted winds (3-5 days)
- (v) possible corrections of (iv) due to on-site measurements.

The system is then started and results are

- printed
- stored on disc or magnetic tape for later analyses
- plotted on colour screens (if available) and plotters.

The results are presented as oil trajectories, oil-infected areas, oil landing in specified shore areas, estimates of maximum hydrocarbon concentrations in selected sea areas, drift times to the various locations, amounts of oil evaporated, dispersed and collected by combat actions, cost associated with the spill, etc.

When new information is available these are entered interactively and long-term forecasts are computed when necessary.

(i) Reports from the spill site

Reports from personnel combating the oil, the on-scene-commander, research and other vessels and from others present.

(ii) Air surveillance

Use of specially equipped aeroplanes with, for instance, side-looking radar. The use of aeroplanes will also improve the possibilities of locating and following oil when it is dark, foggy, etc.

(iii) Buoys

Drift buoys may be placed in the oil on the sea. These buoys will be designed to have the same drifting properties as oil on the sea, and they will thus follow the drifting oil.

As for positioning and reporting, the following systems may be used:

- regional positioning systems used by ships
- satellite positioning
- radar observations by ships in the neighbourhood.

(e) Computer results

Both the deterministic and stochastic model can be used either alone or in a combined mode, the SLIKFORCAST mode. In order to facilitate this last option it has

been necessary to ensure that the two models have identical grid systems and that the input/output options are compatible.

For both models, therefore, one may specify 15 different shoreline areas, five sea straits and five critical sea areas for which oil spills characteristics are computed.

#### OILSIM - The deterministic model

The deterministic model aims at oil spill simulations for a specific spill situation.

The model is structured into modules, each simulating the various physical and chemical processes as described in the previous sections.

An efficient and easy operational procedure is of great importance for the use of the model. This is especially true for its implementation in emergency situations, i.e. for an operational tracking and prediction of oil slick movements in case of an actual blow-out, tanker accident or pipeline rupture. Special emphasis has, therefore, been given to a user-oriented man-machine interface, allowing the operator to update the simulations against field observations.

Some of the major output parameters are:

- Accumulated amounts of oil on shore
- Accumulated amounts of oil dispersed and evaporated
- Accumulated amounts of oil collected by primary and secondary combat actions
- Accumulated number of hits and drifting oil in each gridpoint
- Drift times to various shore locations
- Positions of drifting oil at every time step
- Estimates of hydrocarbon concentrations in given critical sea areas
- Accumulated surface area affected by drifting oil.

The output may be presented on a line printer, on TV-screens or on hard copy drawings. A photograph from VERITAS Simulation Centre where OILSIM may be run is shown in figure X.

#### SLIKTRAK - The stochastic model

As previously mentioned, the stochastic model accumulates results for a number of simulations, maximum 5,000, in order to generate the probabilistic results for a given blow-out location. For each simulation the values of the various parameters discussed before are chosen at random within the given range. The output thus gives the "average" impact forecasts and its uncertainty range resulting from the different combinations of the uncertainties in the blow-out conditions.



# OILSIM OPERATED AT SIMULATION CENTRE.

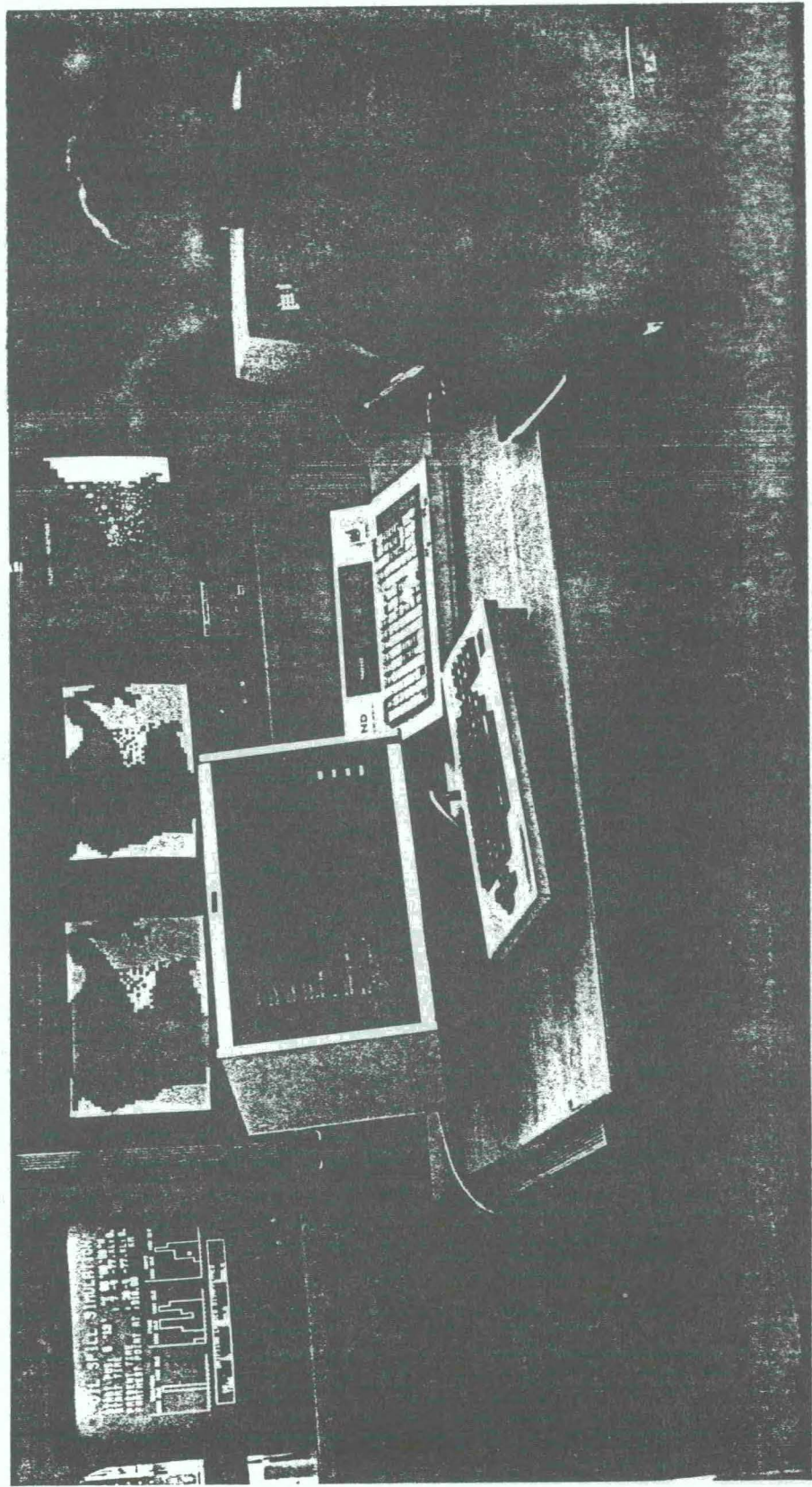

Figure X

Some of the major output parameters are:

- Statistics for tonnes of oil on shore (min., max., avr.)
- Rate of oil shoring (avr., max.)
- Drift times to shore (min., avr.)
- Tonnes of oil collected at primary and secondary combat
- Tonnes of oil dispersed in critical sea areas
- Drift times to critical sea areas
- Concentration estimates in critical sea areas
- Accumulated spill trajectory plot
- Pollution cost estimates.

The outputs may be presented on a line printer or as drawings. An example of a trace plot is given in figure XI.

(f) Sample calculations

In what follows we shall briefly present some example results from the SLIKFORCAST program system. For this illustration examples have been chosen from the Norwegian Continental Shelf.

The average amounts of oil onshore for the different sites may be seen in figure XII. The amounts are expressed both in percentage of the average amount of spilled oil and in tonnes. Combat operations are included in the results.

As may be seen, the amount of oil reaching the shore increases steadily as we proceed from south to north. The reasons for this are both the decreasing distance to the shore, the residual current pattern and the prevailing wind patterns at the different locations.

The question of oil combat plays a key role in the debate on oil pollution impact. Figure XIII gives a schematic presentation of the fate of the oil spilled at the three sites. The results show an increase in the importance of combat actions with decreasing distance from the shore. For greater distances, the amount of oil dissipated increases.

# OIL TRAJECTORIES FROM SLIKTRAK

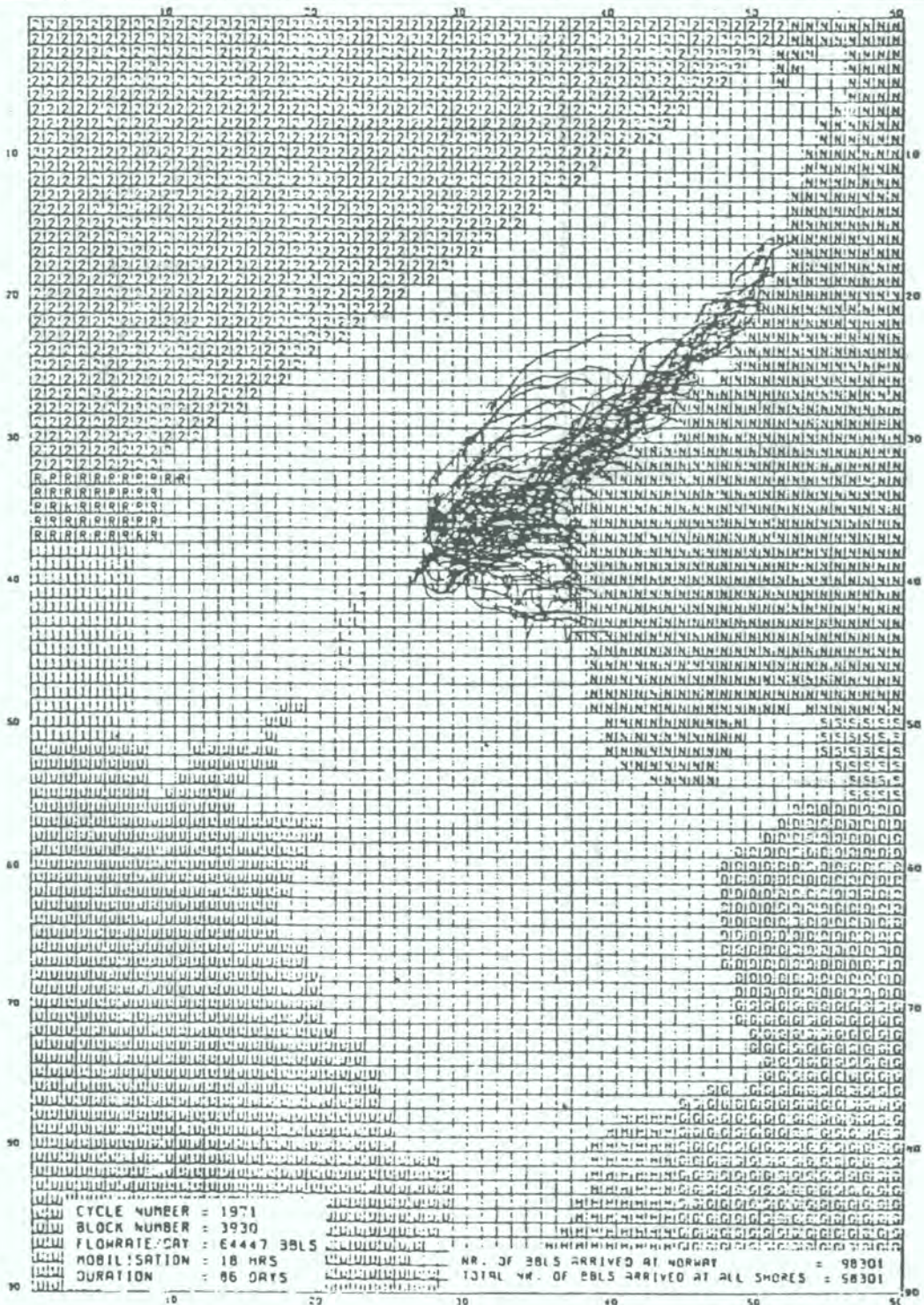

Figure XI

# AVERAGE PERCENT OF OIL ONSHORE FROM AN ASSUMED BLOW OUT AT TWO ONGOING AND TWO PLANNED OIL PRODUCTION SITES

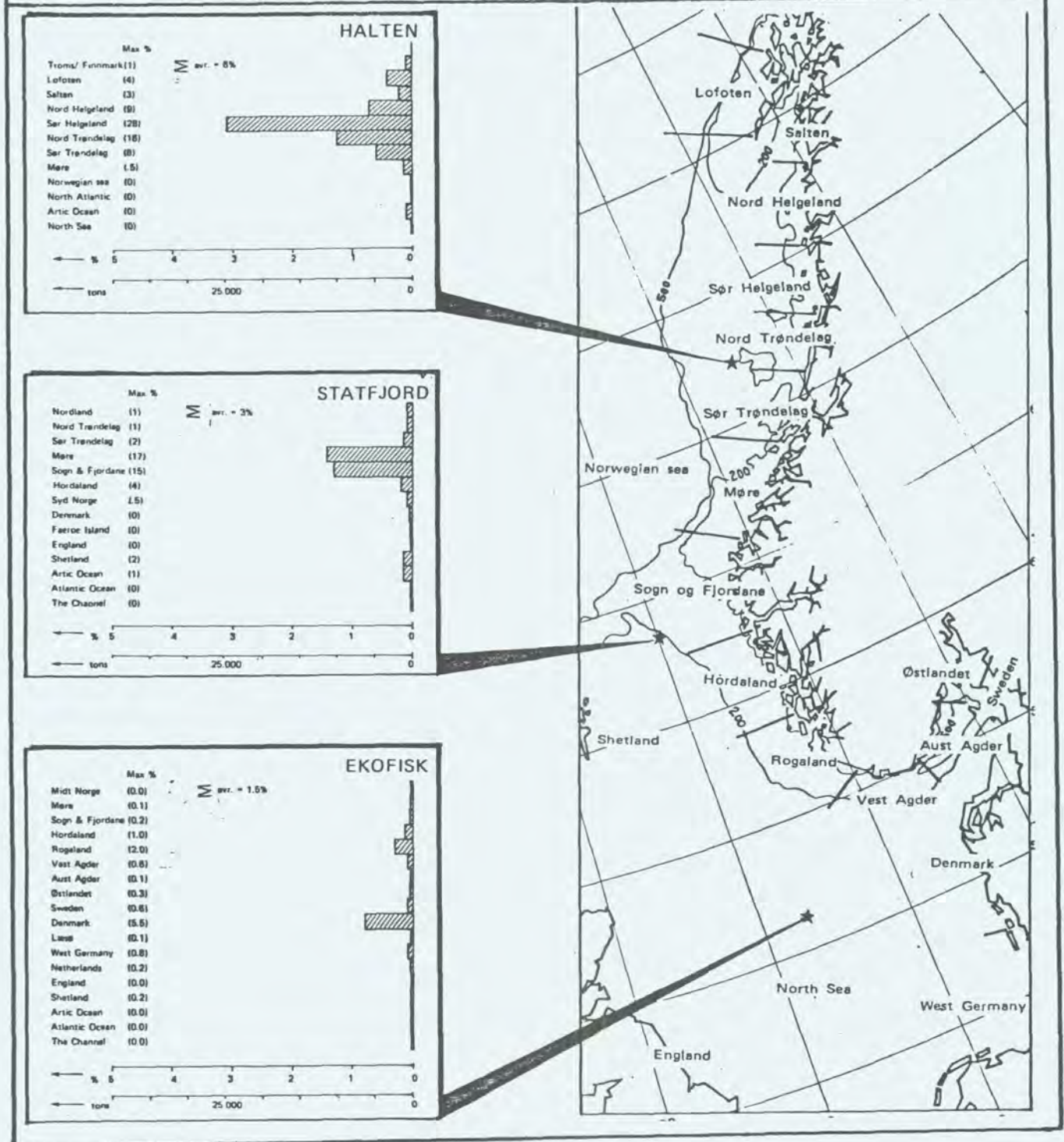

Figure XII

# AVERAGE TOTAL OIL BUDGETS

a — INCLUDING COMBAT ACTION

b — EXCLUDING COMBAT ACTION

Removed by primary combat action

Evaporation and natural dissipation

Removed by secondary combat action

Amount of oil reaching the shore

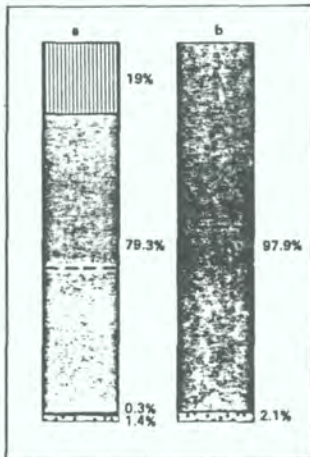
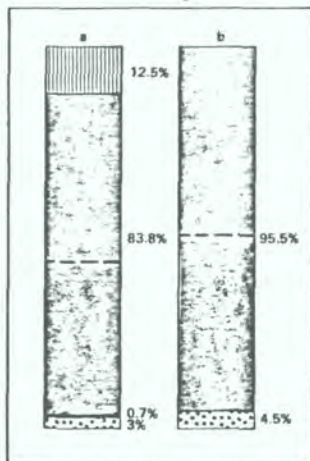
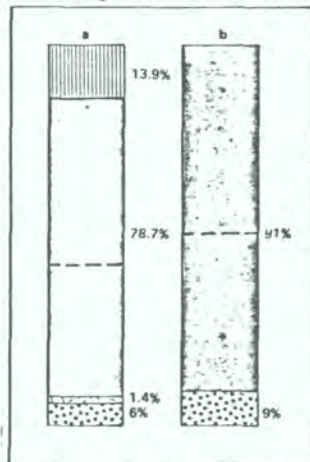

Figure XIII

The table below also shows the estimated average maximum concentration in three critical sea areas in the North Sea (EKOFISK Area).

Estimates of average max. hydrocarbon concentrations  
in critical sea areas (c) and average min. drift  
times (t) to the indicated area.

---

Sea Area	Winter		Summer	
	c (ppb)	t (days)	c (ppb)	t (days)
Ekofisk	260	1	220	1
Great Bank	31	11	25	15
Coral Bank	29	17	13	18

---

According to the results we may expect almost an order of magnitude lower concentration levels at the Great Bank and Coral Bank areas than in the sea area adjacent to the spill site. The computer concentration levels near the platform (250 ppb) seem reasonable compared to the measured values during the Bravo blow-out (Ref. 2). It should also be noted that the computer drift time to the Coral and Great Bank areas is of the order of two weeks. The oil will then be of an age where it is generally considered to represent a lesser threat to fish resources.

Figure XIV shows results of the deterministic simulations for four different days. Both the instantaneous position of the "thick oil" area and the total area of oil impact are shown together with observed oil drift and spreading. The results demonstrate a typical short-time forecast during a blow-out situation. It is worth noting that the width of the simulated "thick" oil slick is mainly a result of the tidal effect. This is because the various oil lots are situated at different phases of the tidal cycle.

Figures XV-XVI show a summary of a simulated blow-out at two of the areas. The coastal areas with highest spill impact correspond to the results from the statistical simulation results. A pronounced feature of the results is the rather extensive sea surface area affected by the drifting oil.

# DETERMINISTIC OIL SPILL SIMULATIONS NORTH SEA — BRAVO BLOWOUT

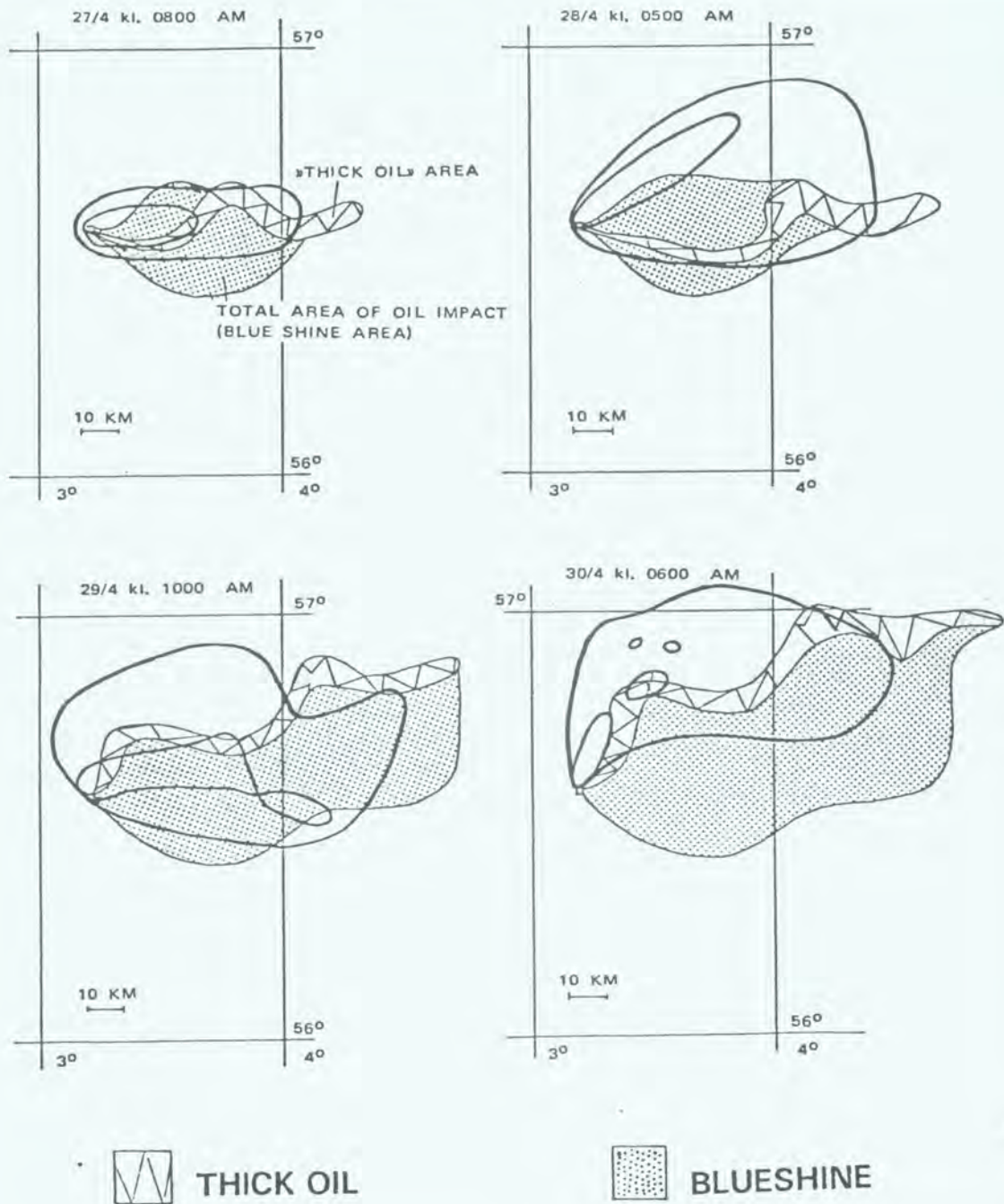

Figure XIV

# SUMMARY OF DRIFT AND SPREADING

## (SIX MONTH BLOW-OUT)

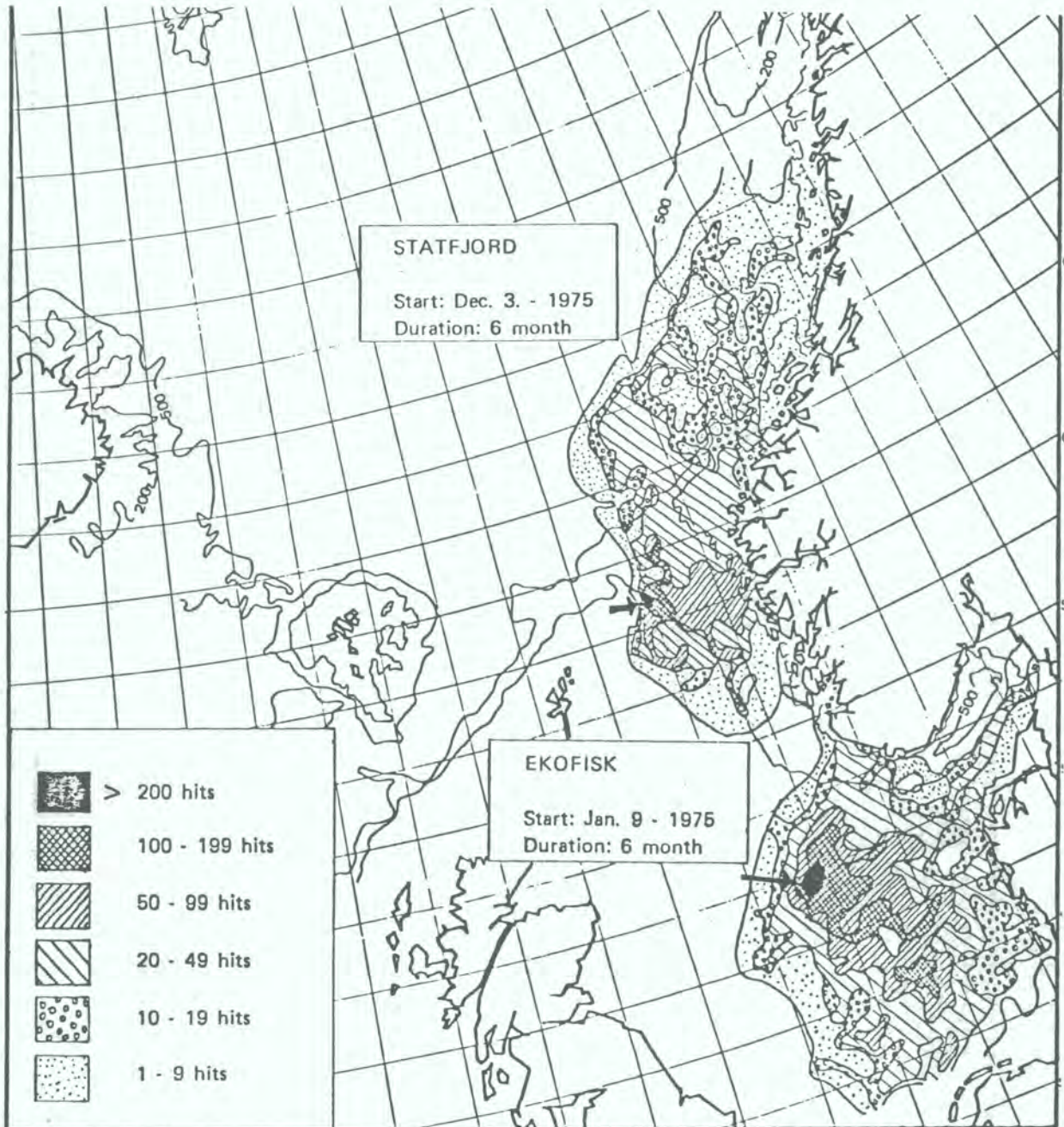

Figure XV



# OIL AFFECTED AREAS FROM OILSIM

NUMBER OF DAYS WITH OIL IN THE AREA

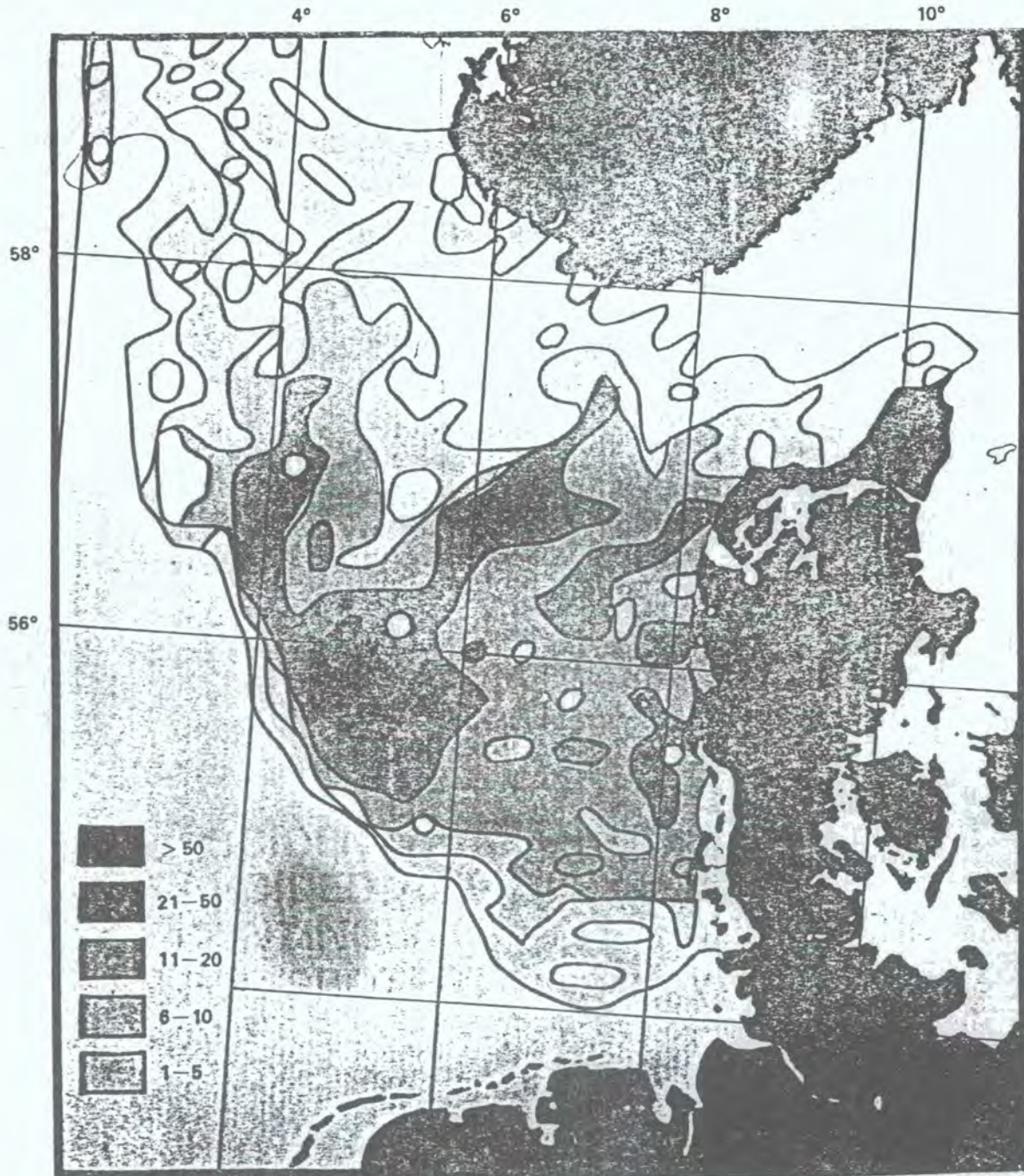

Figure XVI

## CONCLUSIONS

The most important conclusions from what has been discussed in this paper may be summarized as follows:

1. Concerning the operational spills, which account for the greater part of the oil spills, a substantial reduction is expected in the future due to stricter regulations and follow-up. Also the increased cost of oil gives an incentive to take care of waste oil for reuse.
2. Although accidental oil spills in the global perspective represent only a minor part, they nevertheless constitute serious threats to the local environment. The risk of such spills, however, may be reduced to an acceptable level through proper quality assurance.
3. Accidents cannot be completely avoided and the objective must then be to reduce the negative consequences, by stopping the outflow, preventing the oil from spreading and removing it as soon as possible. Even if this may be very difficult and sometimes impossible, a lot may be achieved by having an efficient oil contingency system for protection of vulnerable areas.
4. A computer-assisted oil spill contingency centre will produce useful information for people designated to make decisions concerning combating oil spills and for creating, evaluating and testing contingency plans.

The output information should be presented in a clear, precise and understandable way, and communication channels should exist for transmitting data, maps, printouts, etc.

The establishment of an oil spill contingency centre requires both hardware, software and educated personnel (annex II). The oil spill contingency centre can be run as a general purpose computer centre, and then be staffed with additional people when serious accidents occur.

VERITAS has been actively engaged in performing risk analyses in different parts of the world, development of simulation models for the fate and effect of oil spills, establishing and running a simulation centre and co-operating with a task force in blow-out situations. Also, VERITAS has gained know-how and experience from co-operation with research institutions, operators and authorities. In this context especially, the co-operation with the Norwegian Continental Shelf Institute (IKU) is of value (annex III).

Annex I

RISK ANALYSIS

The system description in the risk analysis study should contain the following information:

a) Offshore petroleum production

- The number of rigs
- Types of platforms, i.e. semi sub, fixed platform, etc. and size of platform
- Location of rig
- Number of wells per field, production rate of oil and gas, type of well, blow-out preventing safety equipment
- Number of exploratory and development wells drilled per year
- If possible - size of field, recoverable reservoir size

b) Offshore pipelines

- Location of pipeline
- Dimension and length
- Medium transported
- Pressure and flow rate
- Coating and burial
- Depth of pipeline

c) Tanker loading facilities

- Location
- Number of tanker arrivals per year
- Total throughput of oil per year
- Loading rate
- Maximum and average size of tankers loading at terminal
- Type of loading facilities at terminal, i.e. fixed sbm etc. and capacity and utilization of each
- Sailing regulations, harbour management, etc.

d) Tankers

- Sailing routes
- Number of tankers on each route
- Size distribution of tankers
- Average size of oil loads, type of oil carried
- Sailing regulations, vessel speed
- Other marine traffic in terms of traffic densities, typ1 880/1 and sizes of vessels

Hazard Identification

The hazards will be identified and listed to establish hazard scenarios. The objective is to cover the main hazards or mishaps. The hazards will be expressed in terms of accidents they may lead to.

Possible spill events will be identified in terms of:

- Type of event
- Location of leakage
- Possible leakage amount
- Possible leakage rate

Estimation of Accident Probabilities

The accident probabilities will be estimated on the basis of the system description, accident statistics - world-wide and for the considered area - as well as theoretical models, previous analyses and experience within VERITAS.

Estimation of Spill Probabilities

From the results of section 3 (above), spill probabilities will be estimated in terms of

- Location of spill
- Size of spill in terms of
  - . large spill
  - . small spill
- Spill source
- Spillage rate

Annex II

EXAMPLE OF HARDWARE FOR AN OIL SPILL CONTINGENCY CENTRE

1. Minicomputer

A powerful process computer. The computer should have a memory of at least 128 Kbytes.

2. Disk

A disk system will be included for secondary storage of programs, operating system, editors, compilers, etc.

3. Magnetic tape station

A tape station may be necessary for input of wind and current data.

4. Printer

The printer will produce reports and print plots of the simulation run (300 lines per minute should be sufficient).

5. Diskette

Instead of inputs by cards, a diskette system will be used. Each diskette may contain up to 296 Kbytes.

6. Process console/tracker ball

The process console and tracker ball are used for the interaction between the operator and the simulation program (start/stop, change values, playback, etc.).

7. Colour graphic display units

To present the results during a simulation run, colour TV-screens are used. The information displayed on the screens is written into graphic buffers. By combining buffers, the information is displayed in different colours.

Annex III

SERVICES OFFERED BY IKU IN CONNECTION WITH OIL SPILLS

1. Blow-out simulation

A computerized reservoir program for simulation of reservoir under blow-out conditions has been developed at IKU. The program will simulate the flow of fluids and gas in the reservoir and up to the wellhead, based on reservoir data.

2. Collection of oceanographic and meteorological data

IKU can carry out data collection in areas where oil spills may occur. This will be based on analysis of historical data. IKU can also give advice on how to set up a measuring program for the actual area. IKU can furthermore directly carry out data-acquisition on behalf of a contractor.

3. Support of equipment

IKU has developed a special drifter for tracking drifting oil slicks. The drifter is satellite-positioned (Argos system). The satellite positioning system has an accuracy of 1 km reported several times daily. The accuracy of the positioning system could be higher if a local positioning system in the area is available. The Argos system is able to handle several hundred drifters from the same area. The unit price for each drifter varies, depending on what kind of positioning systems are included. The drifter has been tried out in real cases and found to follow oil slicks with high accuracy.

Current meters of the acoustic type could also be delivered. These current meters are specially designed for measurements near the surface and close to the sea floor.

4. Support of manpower

IKU has scientists well trained in measuring and reporting the fate of oil during an oil spill. The group would also be able to give advice on combat activities to optimize the efficiency of the operations.

5. Laboratory support

IKU has a very well equipped laboratory for oil analyses and could therefore assist in testing the physical parameters of actual oils.

IKU can also carry out field analyses and the sampling of oil and water. The water samples may be analysed for the amount of oil in the water column.

REFERENCES

- Audunson, T. et al. (1980) SLIKFORCAST - A multi-purpose oil spill simulation system. SLIKFORCAST - Main report, Det norske Veritas, Hovik, Norway, and IKU, Trondheim, Norway.
- Audunson, T. (1980) The fate and weathering of surface oil from the Bravo blowout. Mar. Environ. Res. 3: 35-61.
- Bishop, J.M. (1979) A proposed climatological oil spill atlas. Proceedings of the workshop on The Physical Behavior of Oil in the Marine Environment, Princeton, New Jersey, May 1979: pp. 3.1-3.10.
- Capehart, B.L. and Welsh Jr., L.W. (1979) A computer simulation of oil spills. Simulation, August 1979: pp. 49-54.
- Diezel, G.F.L., Glass, A.W. and Kleef, P.J., (1976) A computer simulator for the prediction of slick movement, removal by natural means, clean up and potential damages arising from oil spills originating from offshore oil well blow-outs. Its development and application to the North Sea. Shell Report, EP-47436.
- Epple, D. et al., (1977) Controlling pollution of the marine environment: an economic analysis. Proceedings of 1977 Oil Spill Conference, March 1977, New Orleans: pp. 31-34.
- Gloersen, T.C. (1980) Prevention of oil spills at sea through quality assurance of ships and offshore installations. Paper Series No. 80 P003, May 1980, Det norske Veritas, P.O. Box 300, 1322 Hovik, Norway.
- Guidelines for the construction and classification of floating facilities for oily water and slop reception. VERITAS Classification Note No. 12, Oslo, January 1978.
- Guidelines for the classification of ships intended for emergency use in oil recovery operations. VERITAS Classification Note No. 12, Oslo, January 1978.
- Higher risk sea areas - A risk analysis. Oil Companies International Marine Forum, London, 1979.
- Imbue, R. and Karwan, K.R. (1979) Computer searching for pollution clean-up equipment. Proceedings of the Joint Oil Spill Conference, Los Angeles: Washington, D.C., American Petroleum Institute: pp. 257-260.
- International Convention for the Prevention of Pollution from Ships, 1973. Protocol of 1978. Inter-Governmental Maritime Consultative Organization.
- Jenssen, T.K. (1979) Probabilities for oil spills from oil carriers sailing to and from the Mongstad-refinery. Det norske Veritas, Report No. 79-1028, Oslo, December 1979.
- Krogh, F., Haldorsen, J. and Audunson, T. (1979) OILSIM-a computer program simulating the fate of oilspills. Norwegian Maritime Research, No. 4.
- National Academy of Sciences (1975) Petroleum in the Marine Environment, NAS, Washington, D.C.

Neuman, L.D. The protection and development of the marine environment and coastal areas of the Kuwait Conference Region: The program of the United Nations system. In Proceedings of the Joint Oil Spill Conference, Los Angeles: Washington, D.C., American Petroleum Institute: pp. 287-91.

Oil spills in 1979 - An international summary and review. Oil Spill Intelligence Report, 3 (21).

Page, D.G. (1980) Computer model will aid oil spill clean-up efforts. Sea Technol. September 1980: pp. 10-12.

Schiff, D. Oil spill clean-up can be effective and self-supporting. Environment International, 3: pp. 189-192.



SESSION III: SAFETY OF NAVIGATION AND POLLUTION PREVENTION

- |   |                    |
|---|--------------------|
| 13. Role of Weather Data in Safe Operations in Oil Exploration, Exploitation and Transport                      | Abdul Wahab Dakkak |
| 14. Maritime Traffic Control and Aids to Navigation in the Kuwait Action Plan Region and the Approaches Thereto | R.Adm.H. Hollins   |
| 15. Pollution Prevention and Control  | J. Plenter         |
| 16. Recent IMO Developments Relating to Marine Safety   | J. Deck III        |
| 17. IMO and Its Activities with Particular Reference to the Prevention and Control of Marine Pollution          | J. Wonham          |
| 18. Pollution in the Shipping Industry - Prevention is Better than Cure   | T.P. Hebden        |

ROLE OF WEATHER DATA IN SAFE OPERATIONS IN OIL  
EXPLORATION, EXPLOITATION AND TRANSPORT

by  
Abdul Wahab Dakkak

General Directorate of Meteorology,  
Jeddah, Saudi Arabia

ABSTRACT

The paper reviewed the history of weather forecast services developed since 1958, and points to the expanded services to be provided in the Regional Marine Meteorological Programme. It details the upgrading of the services expected to come on stream in early 1981 and the meteorological data collection station project also expected to come on stream in early 1981. The marine services expected to be enhanced by the upgrading and additional data collection include: weather and sea bulletins including forecasts and warnings, real time data and information services, climatological sources and special services used in conjunction with such events as oil rig movement or oil spill clean-up.

## INTRODUCTION

It is difficult to think of any marine operation that is not affected to some degree by wind, the sea, visibility, or some other related parameters. Most operations can be carried out more safely and with more efficiency if there is foreknowledge of changing conditions: a squall moving across the area, higher waves, or poor visibility. With this knowledge the ship's captain or the superintendent of the operation can take appropriate action to alleviate the threat.

Data from ship observation stations, land radar, satellite and upper-air stations are essential. But data alone will not provide the captain with the whole answer. The total service includes communication of all the various data to a computer centre or a forecast office, where they are organized, forecasts are derived, and finally, using a knowledge of the planned operations, tailored forecasts are provided by radio or some other means to the marine operator.

It is the purpose of this paper to discuss briefly and in general terms the use of weather information and present services, and then to sketch our plans for the near future.

## REQUIREMENTS

Principal marine activities in the Kuwait Action Plan (KAP) Region include shipping operations, involving both tankers and various kinds of dry cargo ships, oil exploration and drilling, commercial fisheries, industrial development in the coastal areas and marine recreation. All of these activities are affected by wind and waves. Air and sea temperatures, visibility, sea currents and the tide are also of general interest. With the possible exception of fisheries, the interests of this group, while primarily focused on all aspects of the oil industry, are involved in the whole spectrum of marine operations. These functions and responsibilities are spelled out in the Technical Plan for the Regional Marine Meteorological Programme, which will be discussed later.

Shipping operations involve the transit of tankers and other ships, many of them large, through congested waters, their berthing, loading and unloading of crude oil and other cargo in port areas.

## PRESENT SERVICES

The various governmental weather services in the KAP Region were generally developed to meet the needs for route and terminal forecasts for air transport operations. To a large extent the national forecasts are still concerned with aviation services and with general forecasts and warnings for the public. Some services are available to serve marine interests. For example, in Saudi Arabia the meteorological offices in Dhahran and Jeddah issue routine forecasts daily for the KAP Region and the Red Sea, respectively. Also, mariners can receive briefings either in one of the meteorological offices or by telephone. However, marine services have not developed equally with those for aviation. Therefore, a Regional Plan is being implemented, which will be described later.

In order to arrange for a complete and specialized weather service in support of offshore operations, the Oil Companies Weather Co-ordination Scheme (OCWCS) was established in 1958 following the destruction of an offshore drilling rig with heavy loss of life due to unexpected high seas in Qatar waters. The 22nd annual meeting of the Oil Companies Weather Co-ordination Scheme (OCWCS) was held at Abu Dhabi in February 1980. Most of the oil companies in the area are members, and the Saudi Arabian Department of Meteorology is an honorary member of the Scheme.

The forecast work is carried out by the International Meteorological Consultant Services (IMCOS). Supplementing the observational data and basic prognoses available from various countries through the World Meteorological Organization's Global Telecommunications Services are weather and sea-state observations from over 40 Weather Reporting Oil Company Stations and from tankers in the area. Forecast offices are set up at oil company bases and on offshore rigs so that there is a close liaison between the meteorologists and the operators. Forecasts are pinpointed for operational locations and issued at times dictated by operational considerations. Special forecast coverage is given for operations such as rig moves, pipe laying, phases of drilling (especially from drillships) and for tanker movements.

#### REGIONAL MARINE METEOROLOGICAL PROGRAMME

The First Regional Marine Meteorological Conference, convened by the Government of the United Kingdom of Saudi Arabia at Jeddah, September 1977, recognized the need to develop a joint programme to meet the marine meteorological requirements of the Region, the Gulf of Oman, and the Arabian Sea waters off the Oman coast.

A formal arrangement concerning the Regional Marine Meteorological Programme (RMMP) was finalized in Jeddah in January 1980, by Bahrain, Iraq, Iran, Kuwait, Oman, Qatar, Saudi Arabia and the United Arab Emirates, which laid down terms of agreement and adopted a technical plan for the complete system necessary to provide a marine meteorological service. Steps are now under way to implement the Programme and Technical Plan.

The importance of the RMMP and its efforts towards the protection of the Marine Environment was recognized by the Conference of plenipotentiaries for the protection and marine development of the marine environment and the coastal areas held in Kuwait during 15-23 April, 1978.

A resolution calling upon the Secretary-General of the World Meteorological Organization (WMO), and the Executive Director of UNEP to extend co-operation in this regard was also adopted.

The Conference accepted the offer by Saudi Arabia to host the Regional Marine Meteorological Centre as well as the office of the Executive Director. The Centre and the office of the Executive Director are planned to be established on the coastal Dhahran-Jubail region.

As a first step, arrangements were made for a team, consisting of Saudi Arabian officials, a marine meteorologist, a communications expert, and a meteorological facilities specialist, to make a detailed two-month survey of the available facilities and assistance in the appropriate countries. Their mission is completed and a report of their findings will be presented to a meeting of the Board of the RMMP in January 1981.

## RELATED METEOROLOGICAL DEVELOPMENT

A specific meteorological programme, such as marine meteorology, draws upon the strengths of the basic meteorological programmes in the various countries around the sea area of the Region, and indeed to some extent upon the global systems of the World Meteorological Organization. Any additions to the observational system, the communication linkages, processing and dissemination facilities, as well as research and training will help to strength the Regional Marine Meteorological Programme. All the countries concerned have ongoing reviews of these factors, along with upgrading of the various basic systems.

In Saudi Arabia, for example, two major improvements are under way in the basic meteorological programme: the Meteorological Upgrade Project and the completion of a Seventeen Automatic Weather Stations Project.

The Meteorological Upgrade Project is built around a large Control Data Cyber 170-730 and two Cyber 18/20 computers. The message switching capability will result in observational data moving to the forecaster in the field with fewer processing and transmission errors and a minimum of delay. In addition, basic analyses and prognoses will be prepared at the new National Meteorological Centre, which will be provided to meteorological offices, including the Regional Marine Meteorological Centre (RMMP). Parts of this project became operational in early 1981.

The Seventeen Automatic Weather Stations Project includes four marine meteorological automatic stations, as well as additional synoptic stations and air quality monitoring stations. Two of these will be on the coast of the Region.

The automatic marine meteorological observation stations each include a wave-rider buoy, which will provide wave height and period and sea-surface temperature data. The normal meteorological parameters of wind speed and direction, air temperature, humidity, and atmospheric pressure, will also be transmitted from each station. While a tanker is loading through large high-capacity pipes, high winds and accompanying waves can create danger to the ship and the possibility of a pollution incident. The onset of high winds and waves must be anticipated in time for the master to disengage his ship and find sea-room.

Drilling rigs are very sensitive to winds and waves while being towed or repositioned. For example, a jack-up platform is floated to the drilling site where the legs are lowered and the structure raised above the direct influence of waves. While under way by tow, waves of two metres may necessitate lowering the legs or taking evasive action by moving the rig to quieter waters. A warning time of 12 to 24 hours may be required to allow the rig to be directed to shelter.

For the more critical of such operations it is necessary for the marine forecaster to be completely familiar with the seaworthy qualities of the equipment being moved, and he must work closely with the operational Centre. The local bathymetry of the seabed and the meso-scale character of squalls and land-sea effects must be incorporated into the environmental advice.

Fisheries and marine recreational activities need information concerning wind, waves, visibility and the tides. They particularly need advance warnings of conditions dangerous to their vessels. For enhanced fish catch, it is useful to have a knowledge of the distribution of water temperature. The collision and loss of a loaded tanker due to an unanticipated intense squall or impaired visibility could seriously affect the quality of life along the shores and in the open waters of the Region for years to come. Accurate and timely warnings of storms, squalls, fog and other potential environmental hazards can help prevent such a tragedy.

An important aspect of many marine activities is the climatology of the marine atmosphere and the sea, the variability and expected occurrence of wind and waves, visibility and other parameters. Statistical information on environmental conditions is required for the planning of marine operations and for the design of vessels, structures and works exposed to the marine environment.

Considering these requirements, marine services can be grouped as follows:

(a) Weather and sea bulletins including forecasts and warnings:

All marine activities require warnings of impending hazardous conditions, such as high winds and waves. For many of these activities poor visibility also constitutes a hazard. Marine bulletins are required whenever conditions warrant, during the day or night. In addition, routine forecasts are required two to four times daily for wind speed and direction, air and sea temperature, visibility, waves and tidal anomalies.

(b) Data and information services:

There is a requirement for observational data in real time. For example, a manager may require a knowledge of actual conditions at several points within sea area of the Region. A ship needs to know the harbour wind and visibility as he makes his approach.

(c) Climatological services:

An essential part of the marine programmes is the provision for providing marine climatological information. Among the required products are the mean values of wind, temperature, humidity, precipitation, and atmospheric pressure by month or for shorter periods. Wave records from wave sensors can be processed to provide spectral distribution of wave heights and periods for design of structures.

(d) Special services:

In the movement of oil rigs, which was mentioned earlier, and for certain other marine operations, it is essential that an experienced marine forecaster should be available to work closely with the operational problems and the impact of winds, waves, etc. In some cases the marine forecaster needs to be assigned to the operation base during the movement to provide the very close and continuous support required. Typically, these are infrequent but highly weather-sensitive marine operations with very large resource investments at stake, generally lasting from two to three days up to a week.

There are two principal environmental requirements in connection with an oil spill. First, the operation personnel combating the spill require an analysis of the oil spill area and a forecast of the currents. For fast reaction, this should be computer-assisted. The operation personnel also require a forecast of wind and wave conditions in order to effectively deploy oil containment equipment.

## CONCLUSION

The implementation of the Regional Marine Meteorological Programme supported by improvements in the basic governmental programmes, will facilitate better protection of the marine environment by providing the necessary data. It will further permit

improvements in warnings of hazards to the mariners via the operational marine forecasts. With the assistance of computers, the climatological data base is being extended and more derived products are being produced, which will lead to improved climatological assessment for use in planning structures in the marine area.

It is the firm intention of the countries in the Region to provide the best possible marine meteorological service, so that oil and any other marine operations can be performed safely and efficiently.

MARITIME TRAFFIC CONTROL AND AIDS TO NAVIGATION IN THE  
KUWAIT ACTION PLAN REGION AND THE APPROACHES THERETO

by  
R. Adm. H. Hollins

Middle East Navigation Aids Services,  
Manama, Bahrain

ABSTRACT

The paper describes the hydrology of the KAP region and provides a general description of the aids to navigation employed in the system. It provides statistics on the volume of vessel traffic and describes the principal shipping routes in the region and the hazards associated with each route. It details the number of incidents involving tankers over the last 12 years which were surprisingly low. It then describes the traffic separation schemes at the Straits of Hormuz and Tunb-Farm. A proposal for a traffic separation scheme between the Zakkum and Umm Shaif oilfields as well as a shipping control centre with radar surveillance for the areas South of Das Island was made.



## INTRODUCTION

This paper has been produced by the Middle East Navigation Aids Service (MENAS) which has been operating in the Kuwait Action Plan (KAP) Region firstly as the Persian Gulf Lighting Service and then from 1966 under its present name. Its status has remained throughout as defined in its Memorandum and Articles of Association, that is to say, "a Company limited by guarantee and not having a share capital, and its income applied solely towards a service of aids to navigation in the Gulf and Approaches thereto".

MENAS headquarters are in Bahrain and her Light Tender M.V. Relume is fully fitted out to maintain navigation aids as well as carrying 12 navigation buoys.

MENAS is the Sub Area Co-ordinator for IMO Area IX and is an associate member of IALA (International Association of Lighthouse Authorities).

Since MENAS's current area of operations lies mainly in offshore waters or along the Arabian and Oman coastlines, navigation aids in the Iranian waters have not been considered in any detail.

## HISTORY

The use of the KAP Region as an important waterway goes back over many centuries, and it has been a focal point for Eastern and Middle Eastern civilisations. Latterly it has also held a dominant position in the economies of the Western world and Japan.

Records show that some 4,000 years ago the Babylonian fleet sailed to the Region and that 2,700 years ago the northern end was patrolled by a fleet built by Sennachaerib.

It is assumed that there must have been flares and lights to aid these mariners; indeed there is evidence of them 1,200 years ago since the well known ninth-century Arab historian, traveller and writer, al Masudi, relates that "there are markers of wood erected by the sailors in the Sea of Stezara, in the side of the Uballa and Abadan which look like three seats in the middle of the water, and upon which fires are burnt at night which caution the vessels which come from Oman, Sirif and other parts lest they run upon the Stezara; for if they run there they will be wrecked and lost".

It was not until the late nineteenth century and early twentieth century that navigation aids became an important requirement. The export of oil from Iran having a marked effect immediately prior to the First World War, two major lighthouses were built in 1914, one on Tunb island and the other on Little Quoin Island (Didamar). In addition, an unmanned light vessel was positioned off the entry to the Shatt al Arab and a manned light vessel off the Island of Kais.

Since those days the number of navigation aids available has increased to meet the growing requirements, and the present scope of MENAS's responsibilities is perhaps indicative. Thus in 1952 there were 30 light stations, 50 in 1954, 269 in 1979 and today there are 300. These include Decca navigator stations, light buoys, light floats, light beacons, racons, radio beacons and the manned lighthouse at Little Quoin Island.

## GEOGRAPHICAL FEATURES

The Sea area of the KAP Region is 490 NM long from the Strait of Hormuz to the Shatt al Arab, a day and a half's steaming for a 15-knot vessel. At the Strait it is 27 NM wide between the Musandam Coast and the Iranian Island of Larak. The widest part between Lavan Island and the Jabal Dhanna is 190 NM.

Apart from the Musandam and Ruus Al Jibal Peninsula and the Iranian coastline, the adjoining land is flat and in summer is masked by heat haze, which makes the identification of navigation marks more difficult.

The sea lanes are studded with offshore oil and gas fields, with their oil rigs, platforms and connecting pipelines and in addition pipelines to SBMs. Many fields are still to be exploited. Add to this the shoal waters, particularly along the western and southern littoral, and there are then plenty of problems for the mariner to consider.

## DEPTHS

Within the sea area of the Region the greatest depths lie off the high coasts abutting the Strait of Hormuz, along the Iranian coastline and the Musandam and Ruus al Jibal Peninsula. Depths rarely exceed 40-50 fathoms and decrease to the north of the Region. On the Pearl Banks which cover one third of the area and lie in the southern basin, and along the Arabian Coast, depths are 20 fathoms or less, and shallow banks and shoals abound.

Although these depths offer few problems to cargo vessels, the large tanker routes must lie to the north of Abu Musa Island and Sirri Island. In practice a separation lane exists using Farur and Tunb Islands as the Central Zone markers which divide incoming and outgoing traffic. Proceeding to the north, the route in deep water is past Stiffe Bank, Cable Bank and Shah Allum shoal. Channels restricted by depth are available to all ports on the Arabian coastline. All have been well surveyed and some have been dredged. These include the long channel leading to the new Port of Jebel Ali in the United Arab Emirates, the entrance to the Port of Mina Sulman in Bahrain and a new channel in the harbour to the container berth. Plans exist to improve the Umm Said approach channel in Qatar and to dredge a new channel into Mina Zayed in Abu Dhabi.

The bottom off the Iranian coast is mud, whereas on the Pearl Banks it is hard sand, coral and rock, making dredging operations a major task.

## SHIPPING VOLUME

Before the industrial expansion of the Region took place, most of the ships using it were tankers, the number steadily increasing, as has their size, to meet the demands for oil by the Western countries and Japan. Ships normally kept to specific routes within the Region to and from oil terminals.

From 1970, however, the cargo vessel traffic steadily built up and at a time when ports were not available or capable of meeting the requirements for landing shipments. In consequence, waiting time was considerable.

In 1977, waiting time off Dubai was 50 days, Abu Dhabi 30 days and Kuwait 40 days. With the completion of up-to-date port facilities waiting time has virtually disappeared.

Monthly traffic volume reached its peak in 1977-1978 and has now started to decline, as the undermentioned figures indicating the average number of tanker and cargo vessels entering the Region each month demonstrate:

Year	Tankers	Cargo vessels	Average tanker size
1965	70	30	15-20,000 GRT
1972	760	150	50,000 GRT
1973	800	180	100,000 GRT
1974	820	240	105,000 GRT
1975	600	340	120,000 GRT
1976	740	420 )	
1977	800	500 )	160,000 GRT
1978	810	510 )	
1979	650	450 )	
1980 (six mths)	520	420 )	

Tanker traffic tends to fluctuate over the year to meet winter stock requirements. In recent months the fall in tanker traffic reflects the cut-back in crude oil production and, so far as cargo vessels are concerned, the use of larger ships and containerization.

#### TRAFFIC ROUTES

Ships entering the Region, like the contents of a bottle, must go out through the neck by which they entered. Most of the traffic especially tankers, keeps to well defined routes. A small percentage of tankers call in at one or two additional terminals to top up, principally those which have been prevented from loading fully at their first ports of call because of draft limitations in channels leading to loading jetties or SBMs. Some cargo vessels make calls at three or more ports, their routes being dictated by ports to be visited. Even so their routes are usually up or down the Region on the side they started, with very little crossover traffic.

Traffic routes in general use are shown in figure I.

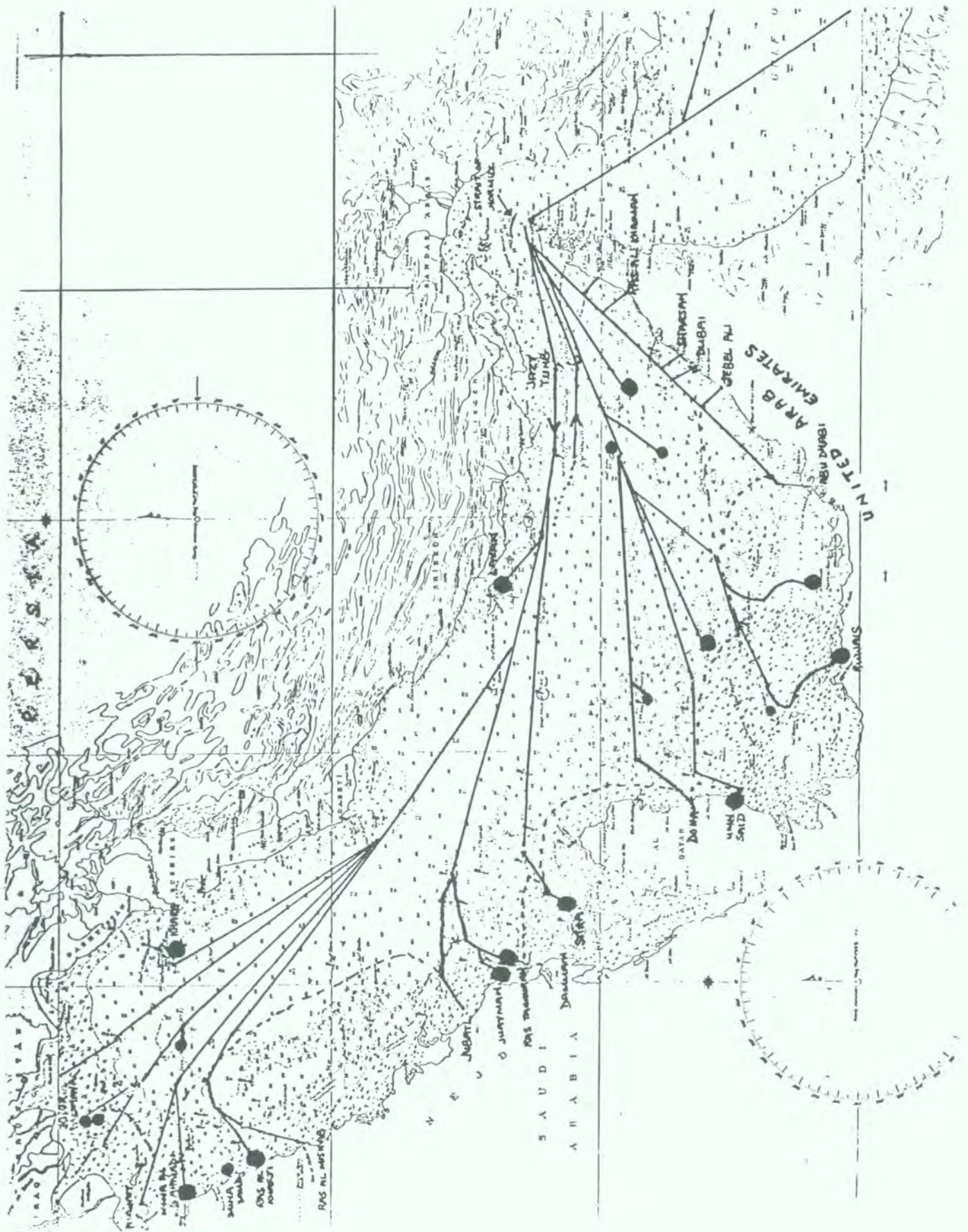

Figure 1: Main traffic routes and main petroleum terminals (●)

AVERAGE MONTHLY PORT OR TERMINAL CALLS BY SHIPPING

The figures given below are the average figures for the first half of 1980.

a) TANKERS

Port/Terminal	Number	Average NRT
Mina al Bakh	4-5	100,000
Khor al Amaya	4-5	100,000
Mina al Ahmadi	35-40	35-40,000
		130,000 (Sea Island)
Shuaiba	12	35,000
Mina Saud	4	35,000
Mina Abdulla	7	28,000
Ras al Khafji	15	58,000
Ras Tannurah/Juaymah	250	132,000
Sitra	30	40,000
Umm Said	14	70,000
Halul	10	68,000
Das Island	25	91,000
Jebel Dhanna	37	70,000
Arzanah	1	35,000
Mabarras	1-2	35,000
Fateh	9	35,000
Sirri	1	50,000
Abu al Bokhoosh	1-2	90,000
Kharg Island	15-20	64,000
Lavan Island	4	26,000
Bandar Mohshahr	8	15,000

Included in the above are tankers such as the Globtik Tokyo 220,000 GRT and Prairal 274,000 GRT which are well above the norm.

b) CARGO VESSELS  
(including Container Ships)

Port/Terminal	Number
Mina Saqr	2
Ras al Khaimah	8
Sharjah	50
Dubai	199
Jebel Ali	27
Abu Dhabi	62
Doha	33
Bahrain	55
Dammam	160
Jubail	4
Shuaiba	30
Shuwaikh	180
Basrah	120
Abadan	10
Khorramshahr	30
Bandar Khomeini	40
Bushire	6

NAVIGATION CONSIDERATIONS AND AIDS

(See figure II for areas)

a) Strait of Hormuz (Area A)

Much has been made of the hazards of and for large tankers carrying potentially dangerous cargoes through this Strait. As already pointed out in this paper the Strait is 27 NM wide and navigationally there is plenty of water, with the average depth being at least 45 fathoms in the centre and greater off the Musandam Peninsula.

Up to November 1979, shipping was routed by Separation Lane both north and south of the Quoin Islands, but after that date, new lanes passing to the north of these islands were brought into use by IMO and all ships, other than coastal vessels, are required to use these lanes.

Apart from depth of water considerations, good fixing aids are available visually and by radar on land objects and in particular there is a manned lighthouse (40 NM) on Little Quoin Island (Didamar), together with a 140 NM radio beacon.

Although in the late 1970s the average number of ships passing was 100 or more per day, the level has now dropped to 70, and over recent months it has been nearer 55 per day. If an average figure of 70 per day is taken this works out at 1.45 ships per hour each way. Some are ULCC or VLCC but in comparison with the Strait of Dover, which is in places half as wide, with shoal water, gales and fog to contend with, then the Strait of Hormuz is generous in its compass and this level cannot be considered high. Through the Strait of Dover for instance, the daily traffic level is 350 ships and there is also a crossover traffic between England and France of 250 ships per day at peak times. In the Strait of Hormuz there is virtually no crossover traffic. Provided the IMO Rule of the Road is followed there is no reason for concern or for increased navigation aids. That there has been no major disaster must stem from the Separation Scheme, with ships required to keep to a specific route in and out of the Region. Credit must also be given to Masters of ships.

b) Southern Area (Area B)

This area, bounded by the 26th parallel in the north and Qatar and the United Arab Emirates in the west and east/south respectively, is probably the most hazardous sea area in the Region. Shallow water abounds as do extensive oilfields such as those at Umm Shaif and Zaqqum and many others taking up less sea room. Exploration is also taking place off Abu Tinah and north of Bulhanine.

In addition to oil terminals and ports already in operation, with their approaches well buoyed and marked, there is the recent opening of the Port of Jebel Ali, extensive industrialization at Ruwais in the Jebel Dhanna, development of the oil fields at Satah, Jarnain and Dalma, with the probable provision of an oil terminal at Dalma Island, and the laying of SBM's 8 NM north of Zarakkuh Island, all bringing an increase of shipping to the Southern Area and in particular to the restricted sea area leading to the Jebel Dhanna.

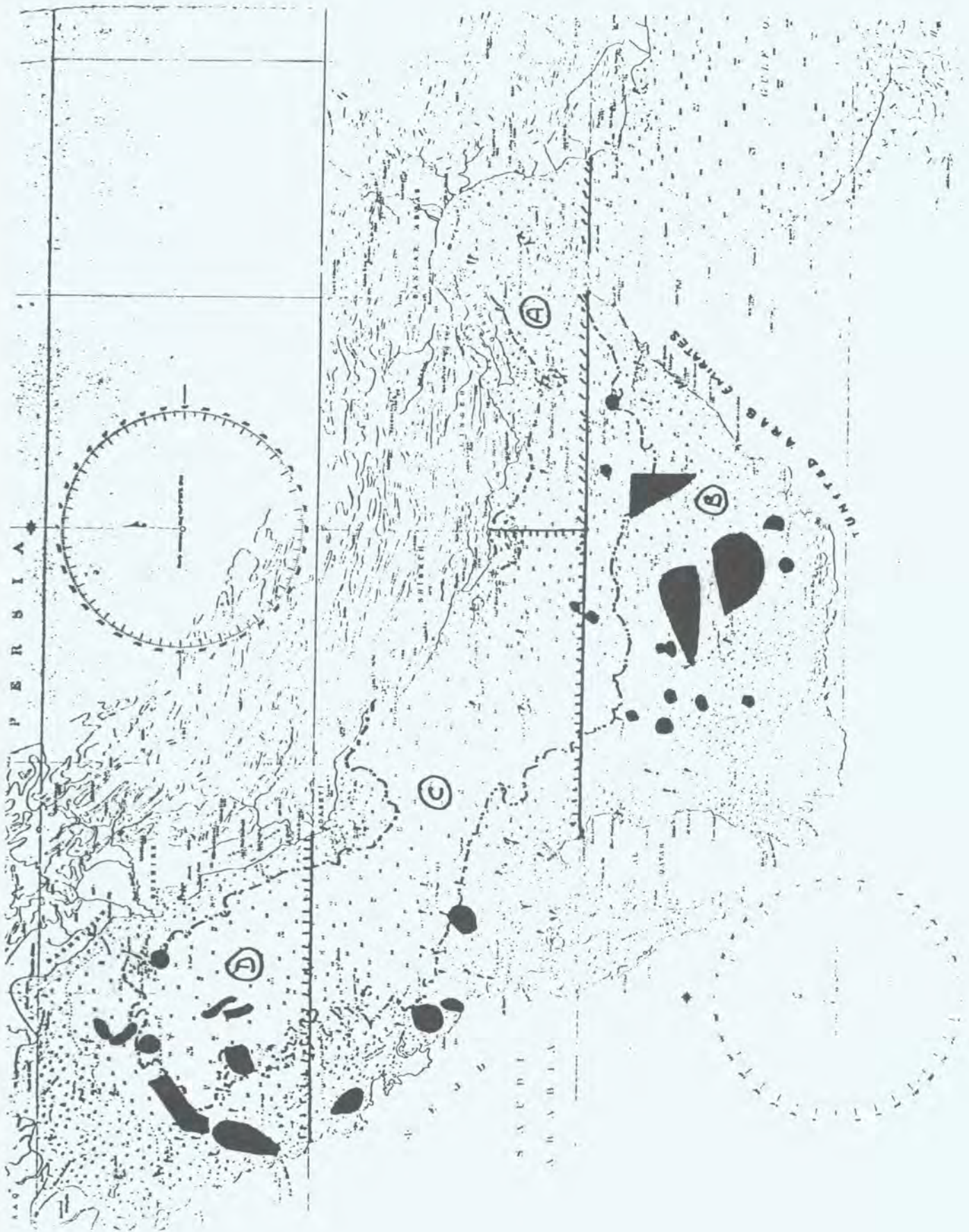

Figure II: Navigation areas and principal oilfields  
20 FM line marked -.-

A Separation Scheme has been proposed by MENAS for the route between the Zaqqum and Umm Shaif oilfields together with a relief route with a minimum depth of 14 metres passing to the west of Das Island, which will be suitably buoyed to take shipping clear of Qatar oilfields and exploration areas.

In view of the traffic build-up to the Ruwais/Jebel Dhanna area which will pass the ZADCO anchorages and SBMs to the north of Zarakkuh Island, and also because of the shipping proceeding to Das Island, Arzanah and Mubarras, we consider that proper control of shipping moving from the eastern approaches between Zaqqum and Umm Shaif oilfields down to Ruwais/Jebel Dhanna will become essential. Ideal sites exist for radar surveillance, and the establishment of a joint shipping control centre for the whole area south of Das Island would seem sensible. This system should dovetail with, or supersede, existing Port Control Radio Systems.

The Southern Area is covered by MENAS Decca Chain 1 Charlie which provides a system widely used by shipping and oil companies.

c) Central Area (Area C)

The area to the north of a line between Kais Island and North Qatar in the south and the 28th parallel in the north is called in this paper the Central Area.

On the Iranian Coast, on leaving the Tunb and Farur Island Separation Scheme, there is deep water available and those hazards which exist are well marked by beacon, light float and racon. Passage to major ports on the Arabian Coast from the above Separation Scheme is through deep water past Stiffe Bank, Cable Bank and Shah Allum Shoal, but as the coastline is approached water starts to shoal at some 20 miles offshore. In consequence, extensively buoyed channels, with depth restrictions, have been installed. Each of these channels is marked at the entrance by a 50 ton light float carrying a racon. Dammam, Bahrain/Sitra, Ras Tannurah and Juaymah take the largest share of traffic in the area and, in particular, Ras Tannurah/Juaymah are the biggest petroleum exporting ports in the Region. The opening of the large port and complex at Jubail will increase Central Area traffic.

The navigation aids for the channels are at present perfectly adequate for the traffic they carry. Port radio systems exist to control traffic together with pilotage.

For the future, integration of port/terminal controls will be essential as industrial seaborne traffic builds up alongside tanker traffic. In addition, when gas fields to the north of Qatar are developed, suitable navigation aids will need to be installed to route shipping clear of this area. Already daily radio navigation warnings are issued by MENAS covering exploration rigs in view of their position astride the main shipping route.

d) Northern Area (Area D)

The area north of the 28th parallel is taken as the Northern Area. On the Iranian side deep water exists, and in the centre a deep water passage is available for shipping proceeding east of the Dorra, Hout and Feridoon oilfields to the Shatt al Arab, Iraq and Kuwait Ports. At the head waters



of the area, shoal water predominates, and buoyed channels guide ships into the Khor Musa, Shatt al Arab, Khor al Amaya and Khow Abdulla.

For ships proceeding up the Arabian Coast past Ras Tannurah and Jubail there are beacons and racons on islands and MENAS has recently placed a 50 ton light float with a racon south of the Dorra field and two buoys, one with a racon, to mark a shoal and the approach route between the Zuluf and Marjan oilfields. MENAS has also recently fitted racons on the Mina al Ahmadi light float and Kubbar Island beacon. In addition it is understood that buoys marking shoal waters are to be laid off islands in Kuwait waters by the Kuwait Port Authority.

a) Navigation aids; general

It will be seen from the above that over the past four to five years there has been a marked increase in navigation aids throughout the Region and particularly in the use of racons. The positions of racons, Decca Navigator coverage and the MENAS Radio Beacon are shown in figure III.

#### FUTURE TRAFFIC TRENDS

A study of likely trends of crude oil exports from the KAP Region shows that the current levelling off is likely to continue for the next two to three years, whereafter the previous upward trend may gradually be resumed. A new factor must be the effect of the 48 in. pipeline from Abqaiq to Yanbo on the Red Sea, now under construction, a projected oil pipeline from southern Saudi Arabia to the coast of Oman and a further projected oil pipeline from the United Arab Emirates oilfields to Fujaira in the Gulf of Oman. The effect of these pipelines on tanker traffic in the Region is at this stage difficult to quantify. However, there is every reason to believe that a marked increase in shipping over the 1977-1978 level is unlikely in the foreseeable future, particularly as dry cargo vessels entering the Region are not expected to show more than a gradual increase over the years ahead.

It is not considered necessary for a strict control of shipping entering the Region to be introduced, nor for any marked increase in offshore navigation aids beyond those already planned. Where appropriate in new port complexes, local aids and radio control systems must inevitably be developed to suit the needs of the port.

#### BUOYAGE

Since 1978 the KAP Region has been moving towards standardization with the IALA System A buoyage. New ports such as Mina Saqr, Sharjah, Dubai, Jebel Ali, Ruwais/Jebel Dhanna, Umm Said, Dammam, Jubail were planned from the start to be under this system and many have recently changed over. Major channels such as the Das channel are IALA System A and, in 1981, Sitra, Umm Said, Ras Tannurah are due to be altered, as is the combined channel at Ras al Khafji/Ras al Mishab. Miscellaneous Region-wide buoys marking wrecks and hazards are in the process of being changed to the new system.

For the mariner, the unification of buoyage should make his task easier since, in the past, two systems have existed alongside each other. On the Iranian side of

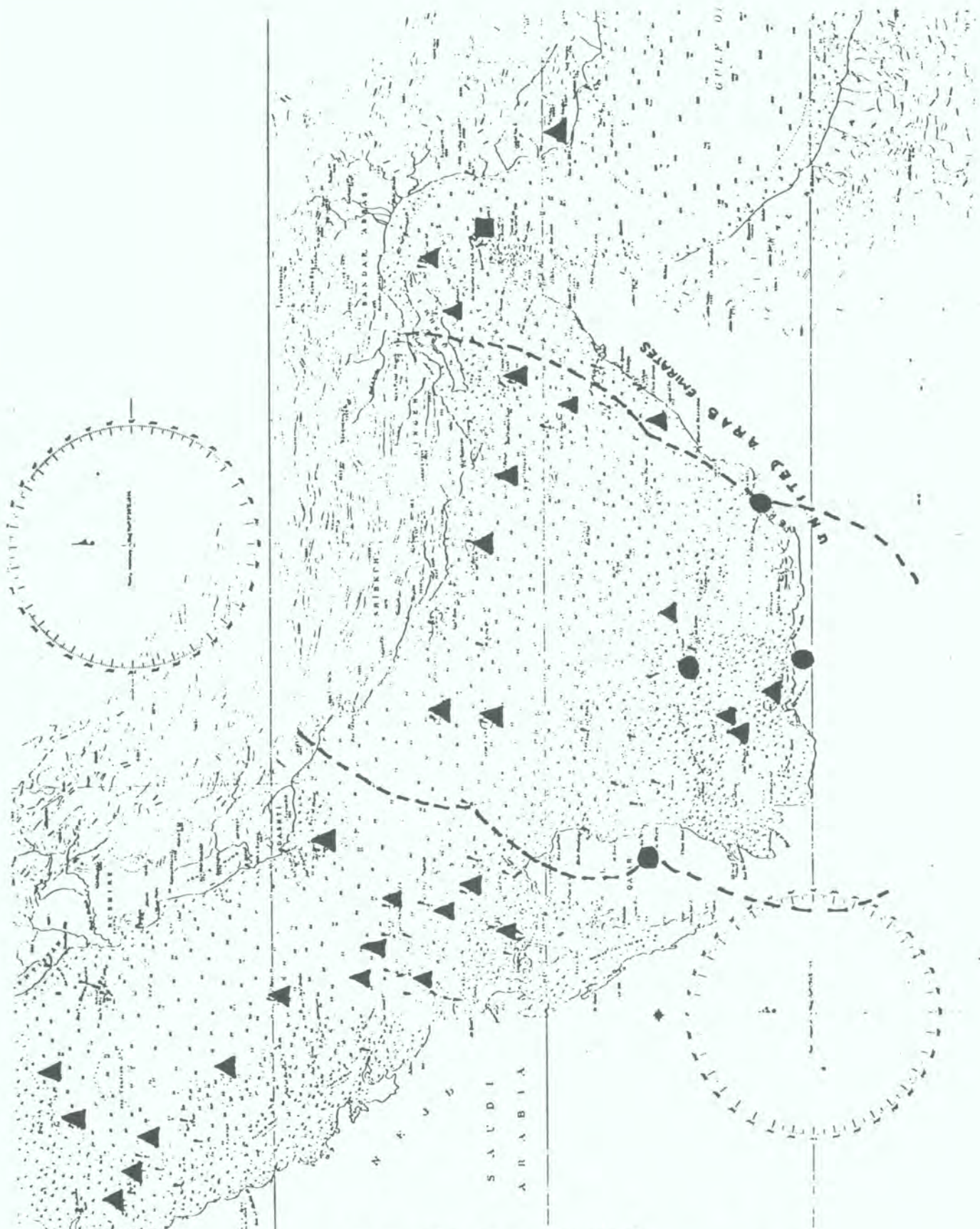

Figure III: Racons (20NM) ▲  
Decca Navigation Stations ●  
Radio Beacon (140NM) ■  
Decca Coverage ---

the Region, System A is also to be introduced.

Damage to buoys and navigation aids by shipping is not infrequent.

#### HYDROGRAPHIC INFORMATION

The KAP Region comes under the Pakistan Hydrographer who is responsible for Area IX. MENAS is the Sub Area Co-ordinator for the Region and Approaches thereto.

Hydrographic information, whether consisting of advice in respect of navigation aids, collisions, groundings, oil slicks, men overboard, ships overdue, indeed any matter affecting the mariner is passed in the form of a Radio Navigation Warning by MENAS through Bahrain Coastal Radio. This information, when appropriate, is also passed to the Pakistan Hydrographer for transmission on the Area IX Broadcast, and to Muscat Radio. In addition, the two ship servicing companies, Gray Swift and Lamnalco are also informed. This service is provided on a 24-hour basis.

For longer-term information, navigation notices are published by MENAS and distributed world-wide to hydrographic authorities and other authorities and agents. MENAS publishes the positions of oil rigs in the Region on a monthly basis and, when informed, broadcasts the movement of oil rigs and hazardous tows.

Over recent years the number of Radio Navigation Warnings has markedly increased and every endeavour is made to keep the mariner currently informed of any change either prior to his arrival in the Region or whilst he is within its limits.

#### CASUALTIES

Over the past 10-12 years there have been a variety of maritime incidents affecting tankers which can be summarized as follows: -

a) Groundings other than dragging anchors	12
b) Fires in engine rooms and accommodation	13
c) Collision in harbour or port area	5
d) Collision at sea	5
e) Sunk whilst in ballast (fire or explosion)	2

None of the above has had serious ecological consequences. The most recent collision occurred in the Gulf of Oman in 1972 when the North Barbosa in ballast was in collision with Sea Star loaded and the latter sank. Two tankers in ballast have sunk in the Region in 1979, subsequent to fire and explosion. Not included in the above is damage incurred during ship handling or berthing in port or by dragging anchors.

Whilst the fact that collision and grounding have taken place is serious enough, and the consequences could be great, the number of incidents is not as high as might have been expected in these confined waters and there do not appear to have been any recorded instances of major oil pollution caused by shipping accidents at sea in the Region.

## CONCLUSIONS

The Strait of Hormuz, though an area through which passes a high percentage of the Western World's petroleum requirements is wide and deep and, provided shipping keeps to the traffic Separation Lanes, no problems should occur.

Navigation aids in this choke point are sufficient.

The number of ships entering and leaving the Region has declined, though over the past six or seven years the ship size has increased.

No major increase in shipping is expected; indeed it could decline further in the short term if new pipelines to be connected to terminals outside the Region become operational.

New major port complexes suitably buoyed and controlled are now available for shipping. Where improvements are appropriate to meet increased needs, studies are already in train.

In the past three years there has been a marked increase in offshore lights and racons to aid mariners on both sides of the sea area of the Region.

Further control of shipping beyond that described in the section headed Southern Area in the chapter "Navigation Considerations and Aids" is not considered necessary at present.

Promulgation of hazards to shipping is maintained at an acceptable level.

The number and types of navigation aids need to be constantly reviewed to ensure maximum assistance for ships, particularly those carrying hazardous cargoes.

POLLUTION PREVENTION AND CONTROL

by  
J. Plenter

SMIT International,  
Rotterdam, Netherlands

ABSTRACT

This paper comments on the sources of oil spills on the high seas. The behaviour of oil after it has been spilled and a rational approach to effectively respond and clean-up on oil spill. A US National Academy of Sciences report on sources of oil introduced into the sea is cited and describes the chemical, physical and biological processes which take place after the oil has been spilled at sea. It further indicates the scope of adequate pre-spill planning necessary to provide a timely response and effective clean-up of an oil spill.

## INTRODUCTION

Protection and conservation of the environment in general, and prevention and control of oil pollution in particular, have become major issues in today's world.

It is all part of the growing concern about the ability of our earth to continue to support life, if no action is taken to halt deterioration of the environment caused by developments such as industrial and urban growth, technological progress, population expansion and rising living standards.

Oil in particular has been a major contributor to this concern. Through all phases - exploration, production, transportation, refining and consumption - oil is a potential pollutant.

However, one has to accept the fact that our modern industrial society needs vast quantities of oil. World-wide transportation systems function primarily on oil and will continue to do so for the coming decades. Industry requires oil as a source of energy and raw material for end-products such as plastics and fertilizers.

As a consequence, one should not expect a change in the huge quantities of oil which are exported from the oil-producing countries, nor a decrease in offshore oil operations. In other words, the threat of oil pollution is not likely to disappear in the foreseeable future.

Both the public and private sectors of our society are aware of this fact and are responding with a variety of measures:

- Governments have adopted legislation;
- National and international agencies have been established to deal with the problem;
- The oil industry itself has increased its efforts to prevent and control oil pollution.

However, one has to realize that approximately 75 per cent of all oil spills are directly or indirectly attributable to human error. This means that even if we had a perfect technology and could prevent all malfunctions or breakdowns of equipment, oil pollution resulting from negligence and human error would continue.

Furthermore, we have to accept the fact that each spill is unique. The type of oil, the location, the volume of the spill and, in particular, the weather circumstances usually vary from spill to spill. It is even possible that a variety of response actions is necessary in the area affected by one spill due to changes in weather and the character of the spilled oil.

Now we are all together in a central place in the Kuwait Action Plan Region. This area, where the presence of oil has been known for over 2,000 years, exports approximately 60 per cent of the world's oil supply.

So far the Region has a remarkably good record in respect to oil pollution. Nevertheless, it is considered to be an area with one of the highest oil pollution risks in the world due to:

- The high concentration of offshore exploration and production facilities, and inshore tanker loading terminals;

- The volume and density of marine traffic;
- The coincidence between areas which have economic, ecological or recreational significance and areas to which the oil, spilled from potential pollution sources, is likely to drift.

The aim of this paper is to contribute to the workshop discussions by commenting on the following subjects:

- The sources of oil spills on the high seas;
- Behaviour of oil after it has been spilt at sea;
- Rational approach to prevent and control oil pollution.

#### THE SOURCES OF OIL SPILLS ON THE HIGH SEAS

The United States Academy of Sciences published a study in 1975 which estimated that approximately 6 million tonnes of oil find their way into the seas of the world each year. This oil comes from the following sources:

- Land installations: 2.6 million tonnes (43 per cent)

This includes river and urban run-off and coastal facilities such as sewage plants, refineries, etc. For example: it is estimated that the river Rhine carries annually approximately 70,000 tonnes of oil to the North Sea.

- Atmospheric transport: 600,000 tonnes (10 per cent)

Some petroleum hydrocarbons initially go into the atmosphere and then are carried down by precipitation into the oceans.

- Natural seepage: 600,000 tonnes (10 per cent)

Scientists have found evidence that for many centuries oil has oozed from cracks in the seabed. Apparently, the oil-loving micro-organisms that live in sea-water are capable of handling this seepage.

- Offshore production: 100,000 tonnes (2 per cent)

It is estimated that 75 per cent of this small amount comes from spills of more than 50 barrels. The remaining 25 per cent is from lesser spills and normal discharges during drilling and production operations.

- Tanker transport: 2 million tonnes (35 per cent)

Approximately one third of the total amount of oil entering the seas of the world comes from transportation activities. However, the share attributable to tanker accidents, the most newsworthy source, is only one tenth of this amount. Certainly not a bad record if one knows that at any given time approximately 100 million tonnes of oil are on board tankers on the high seas. The remaining 90 per cent is caused by operational discharges. As these usually occur during terminal operations, which means close to shore, they can cause quite a lot of damage in the immediate vicinity.

The data given above were, as previously stated, published in 1975, and are valid for the total of the world's waters.

Taking into account that there has been quite an increase in transportation of oil by ships and a great increase in the size of the ships themselves since 1975, one may safely assume that the impact of transportation on oil pollution in the KAP Region is much bigger. Unconfirmed sources claim even a percentage of 85.

#### BEHAVIOUR OF OIL AFTER IT HAS BEEN SPILT AT SEA

For a proper response to the threat of oil pollution it is essential to understand the behaviour of oil after it has been spilt at sea. As soon as oil has been spilt many physical, chemical and biological processes begin at once.

##### Spreading

Usually the first observable phenomenon following an oil spill is the horizontal spreading of oil on water. It is caused by the force of gravity and the difference in surface tension of oil and water. As the oil spreads, the layer thickness will decrease and the influence of gravity will diminish. In most cases the spreading due to gravity is a matter of one hour only. The spreading caused by the difference in surface tension takes much longer.

##### Movement of the oil slick

An oil slick will move in the same direction and at the same speed as the surface water. So currents and winds are the governing factors and determine the new direction. In general an oil slick will move at a rate of approximately 3 per cent of the wind velocity. Winds in excess of 3 on the Beaufort scale usually cause the oil slick to break up into wind-rows.

Although there is a large variety in directions and strengths of the tidal currents in the KAP region, one should also bear in mind the general movement of surface water i.e. west-north-west along the Iranian Coast and east-south-east along the coasts of Saudi Arabia, Bahrain, Qatar and the Emirates. This means that the general direction of spilt oil over a period of time is approximately south-east. This should be remembered if one knows that it constitutes a threat to the following significant areas:

##### - Economic significance

Centralized and coastal-oriented industrialization and urbanization in Saudi Arabia, Bahrain, Qatar and the Emirates.

##### - Ecological significance

High salinity, high temperatures, shallow water, poor circulation etc., in the area of Saudi Arabia, Bahrain, Qatar, and the Emirates.

##### - Recreational significance

Beaches of Bahrain and in the Emirates.



## The process of weathering

The weathering of oil starts immediately after it has been spilt and occurs simultaneously with the spreading and movement of an oil slick. The weathering of oil is a progressive series of changes in the properties of the spilt oil. It proceeds at rates which vary according to the type of oil and the prevailing weather conditions. Major processes which contribute to this weathering are:

### (a) Evaporation

In most cases 25-50 per cent of the spilt oil disappears during the first 24 hours after the spill, due to the evaporation of the light components in the oil. The consequences are increased specific gravity and viscosity of the remaining mixture.

### (b) Dissolution

Some components of oil are slightly soluble in water but this is a time-consuming process which takes care of only a minute quantity of the spilt oil.

### (c) Oxidation

The chemical combination of hydrocarbons in the spilt oil with oxygen is called "atmospheric oxidation". Ultraviolet radiation from sunlight also aids in the oxidation of hydrocarbons present in the spilt oil. This oxidation is called "photo-oxidation". Oil will oxidize more rapidly when it is spread in a thin film. The presence of sulphur compounds in the spilt oil tends to decrease the rate of oxidation. Usually oxidation is a slow process, since only a limited amount of oxygen is capable of penetrating the oil slick.

### (d) Biodegradation

Many species of marine bacteria will oxidize petroleum hydrocarbons by using these compounds as food. It was discovered that these petroleum-eating micro-organisms tend to be most abundant in waters where oil is continuously or intermittently present (e.g. close to places where natural seepage occurs). It has been calculated that complete degradation of one litre of crude oil requires all the dissolved oxygen in approximately 400,000 litres of sea-water. The micro-organisms can only attack that part of the oil which is in contact with the water.

### (e) Emulsification

Emulsification is the process by which one liquid is dispersed into another liquid in the form of small droplets. In the case of oil, the resulting emulsion can be either "oil in water" or "water in oil". Both are formed as a result of wave action.

"Oil in water" emulsions usually come about in freshly spilt oil. It can on occasions remove all visual traces of an oil spill. The persistence of this emulsion is encouraged by the presence of so-called "surface active agents" (waxes or dispersants). Once oil in water emulsions are formed other weathering processes are accelerated.

"Water in oil" emulsions can be formed when water is mixed with viscous oil. Water in oil emulsions containing 50-80 per cent of water are most common and are usually called "chocolate mousse". When this "chocolate mousse" reaches the shore it tends to pick up sand and will form tar balls after the water has evaporated.

(f) Sedimentation

Sedimentation occurs when the specific gravity of the spilt oil exceeds that of the water. After disappearance of the lighter components of the oil due to the weathering process a residue of smaller and denser oil particles is left. These can adhere to inorganic sediment, whereafter the oil will sink. This process is most significant in nearshore areas.

One cannot but stress the importance of a good understanding of the processes described above. This is essential for the evaluation of the extent and nature of the threat posed by a particular oil spill and for the choice of the first response actions.

#### RATIONAL APPROACH TO PREVENT AND CONTROL OIL POLLUTION

The key to an effective oil spill response is sound contingency planning in advance. Oil spills are unpredictable and usually do not occur during working hours on weekdays, or under ideal weather conditions. In view of the limited time available for the setting up of an adequate response once an oil spill is threatening, one has to organize in advance.

Such contingency planning is not simply a listing of names, addresses and telephone numbers. It goes much further and should aim at a situation where one can decide without being under pressure of an oil spill threat.

To indicate the scope of adequate pre-spill planning we listed a number of questions and tasks which need response and action. This list is by no means complete.

What and where are the potential oil pollution sources?

The blow-out of an oil-well usually means a continuous discharge of oil for a period of time and will require a response which is quite different from a tanker accident where one may expect the instantaneous release of a large quantity of oil.

What types of oil can be spilt from these sources?

Composition, specific gravity, viscosity, sulphur and wax contents and pour point of oil are important data. They can indicate which response is optimal. For instance, whether one should take no action at all because evaporation will do the job (aviation fuel), use of dispersants will have the best effect (fresh crude oil), or mechanical clean-up is imperative (fuel oil).

Also important to know is whether, in addition to the oil, poisonous gas may be released. If this is the case, life support equipment, safe working distances etc. should be specified.

What is a realistic estimate of the maximum spill possible?

The oil spill resulting from a tanker accident is usually much larger than the spill caused by the bursting of a cargo-hose during loading of a tanker. The amount of oil that is spilt each hour after a blow-out and the time required for capping operations can usually be reasonably estimated.

What are the most probable movement patterns under various meteorological conditions?

It is possible to have this problem solved by computer. In Europe, Det Norske Veritas developed, in co-operation with the Continental Shelf Institute and a number of oil companies, the Oilsim Computer Program which can predict the physical behaviour of oil spills at sea. Input data include rate of release, location of the spill, evaporation data, current and wind data, etc.

It is at present used to study the impacts of possible oil spills from several North Sea oilfields.

What are the areas which have economical, ecological or recreational significance?

Having seen the beaches of Bahrain and the Emirates, part of the centralized and coastal-oriented industrialization and urbanization, and knowing about the high salinity, water temperatures, shallow water areas, poor circulation etc., a detailed survey of the whole western and southern coast of the sea area of the KAP Region will probably be necessary.

After completion of this survey one should agree which is the best way to protect these areas. Always bearing in mind the fact that so far the beach has always been the best oil-boom and also the final one.

One should further agree on priorities in the event that more locations are threatened at the same time.

Are there any nautical, geographical or meteorological circumstances which may influence pollution combat-operations?

For example:

- During recent pollution combat operations in the Region the presence of coral reefs proved to be a great handicap.
- The non-existence of access roads to the northern beach made beach cleaning a difficult and costly operation in Greece earlier this year.

What is the availability of aircraft and airstrips to facilitate aerial reconnaissance and dispersant spraying?

Aerial reconnaissance is essential during anti-pollution operations. It gives a total picture (bird's eye view) of the extent of the spill and the effectiveness of the combat operations. It should be stressed that oil detection possibilities from surface vessels are very limited. On the other hand one has to remember that usually the picture from the air is much more dramatic.

- During the anti-pollution operations in Bantry Bay (Ireland) an ideally situated landing strip close to the source of the spill made it possible to carry out aerial dispersant spraying in a very effective way.

What is the availability of suitable support craft?

During anti-pollution operations a variety of craft may be required. Apart from small craft such as rubber boats with outboards and small workboats (lifeboat size), the following larger craft may be required for operations taking place offshore:

- oil storage barges;
- vessels with offshore lifting facilities (5-10 tonnes);
- supply boat-type vessels with large aftdeck, roll-on stern and winch for boom launching and recovery.

Accommodation, proper navigation and communication facilities on board these vessels are essential.

There are a number of companies in the KAP Region which operate these types of vessels. However, it would seem that most vessels are chartered to the various oil companies. It is therefore difficult to comment on availability.

What is the availability of support services and supplies?

A few important items are:

- transport facilities;
- lifting facilities;
- welding and burning and general repair facilities;
- supply of ropes, wires, shackles, rubber boats, outboards, plastic bags and sheeting etc.;
- disposal areas for recovered oil.

After all information requested in the foregoing items is available, documented and stored in an accessible way, it is possible to decide in a rational way which pollution combat equipment is most suitable to handle oil pollution at the various locations.

However, the pre-spill planning is not yet complete. Further work includes:

- Assignment of qualified personnel to specific oil spill response tasks;
- The designation of authority during anti-pollution operations and the identification of the chain of command;
- Identification of agencies and persons to be notified immediately in the event of an oil spill;
- Precise description of all jobs (in order of priority) to be carried out in case of an oil spill;

- The setting up of a communications network to assure co-ordination of efforts and effective response;
- Deciding on a training programme;
- Deciding whether one requires total in-house capability to handle each spill, or only a first-aid package sufficient to handle day-to-day spills with, in addition, an arrangement with a reliable and experienced spill contractor.

The foregoing pre-spill planning is all aimed at a rational control of oil spills.

With regard to oil-pollution prevention only the following three items will be mentioned here:

- In some way or other, masters of tankers which run into problems have to be firmly persuaded or instructed to seek assistance at the earliest possible moment. This gives more time for action (Amoco Cadiz).
- Ports of refuge should be established at strategic points along tanker routes, where stricken tankers, which often present a pollution risk, can be brought to and dealt with. Traditionally a vessel would be certain of being given a port of refuge whenever she was in trouble. Even during wartime, a port of refuge would be granted in neutral countries to naval vessels to effect emergency repairs. Nowadays a stricken tanker can become a maritime leper because it has been declared "a grave and imminent danger of pollution to the coasts" (Andros Patria off Spain, early 1979).
- All tankers and other carriers of dangerous goods, old and new, should be compulsorily equipped forthwith with a simple device, both forward and aft, to enable tugs, especially under adverse weather conditions, to make a towage connection quickly, efficiently and with minimum assistance from the stricken ship.

RECENT IMO DEVELOPMENTS RELATING TO MARINE SAFETY

by  
J. Deck III

IMO Consultant,  
Chardon, Ohio, USA

ABSTRACT

The paper describes the results of the two conferences convened by IMO in 1978; The International Conference on Tanker Safety and Pollution Prevention (ISPP) and the International Conference on the Standards of Training, Certification and Watch-Keeping for Seafarers (STCW). The paper details the requirements arising out of ISPP for inert gas systems, steering gear, radar and collision avoidance aids, and inspection and certification. The provisions of the Convention adopted by the STCW conference relating to applicability, control, watch-keeping, certification, qualifications and training are detailed as well as those marine safety oriented resolutions. The paper goes on to describe other work at IMO in the areas of stability, manoeuvrability, traffic separation schemes and collision avoidance systems. The status of coming into force of the instruments arising out of these conferences are reviewed.

## INTRODUCTION

This paper was prepared to be presented at this workshop to review and highlight those recent marine safety activities at IMO which have a direct bearing on marine pollution prevention. The relevancy of its contents and philosophy of purpose is based on the strong interdependence of marine safety activities and marine pollution prevention. Marine safety and pollution prevention have been the terms of reference for the organization since its inception in 1953.

During the twenty-two years of its existence, a number of codes, recommendations, and conventions have been developed and adopted. This paper will discuss the more recent of these that were directed to pollution prevention, or that have a strong influence on, or contribute to, the reduction of marine pollution.

Discussed in substance will be the International Convention on Standards of Training, Certification, and Watchkeeping for Seafarers 1978 (STCW 1978), and the International Conference on Tanker Safety and Pollution Prevention 1978, (TSPP). Recent codes of safety for specific ship applications will be reviewed as well as a discussion of other activities, both ongoing and recently completed, within the structure of IMO's technical committees. Last comes a review of the more significant activities and their status for coming into force.

### STCW 1978

In early 1971, an IMO working group reported, "that in view of the continuing alarming rise in maritime casualties, it is necessary for urgent action to be taken, aimed at strengthening and improving standards and professional qualifications of mariners as a means of securing better guarantees of safety at sea and protection of the marine environment."

Accordingly, in 1971, the Subcommittee on Standards of Training and Watchkeeping was established and given the task of studying the subject and preparing a position to be considered at the joint IMO/ILO Committee on Training or, as appropriate, in connection with other members of the United Nations family. This Subcommittee met on a regular basis and produced a draft convention which was considered by the International Conference on Training and Certification of Seafarers held in London in June 1978 under the auspices of IMO and ILO, (International Labour Organisation).

At the conference, 72 nations agreed on the text of the world's first international convention establishing basic requirements on training, certification and watchkeeping for masters, officers and crews of seagoing merchant vessels.

STCW 1978 has the stated purpose: "to promote safety of life and property at sea and the protection of the marine environment." Based on statistical data that human error in some aspects is a contributing factor in over 80 per cent of maritime accidents, the improved training and qualification standards when implemented should better qualify personnel on board ships to avoid maritime casualties.

The principal provisions in the articles of the convention pertain to the issuance of certificates to seafarers and to the exercise of control with respect to such certificates on all ships when in the ports of a party to the convention. Existing certificates and those issued under national practice to seafarers who

began their sea service before the entry into force of the convention, will continue to be recognized. If an exceptional necessity arises, and under very limited and specific conditions, a dispensation to permit a seafarer to serve in a capacity for which he does not hold the appropriate certificate may be granted. Dispensations will not be granted to masters and chief engineers except in cases of extreme emergency. The control procedures will enable an administration to ascertain that seafarers on ships arriving in their ports will comply with the convention. A ship may be detained in cases of non-compliance with the provisions of this convention, in regard to failure of seafarers required to hold a certificate, to have an appropriate certificate or valid dispensation, or failure of navigational or engineering watch arrangements to conform to the requirements specified for the ship by the flag State.

The annex to the convention contains the regulations which establish standards for certificating masters, deck and engineering officers, and for issuing authorized documents to unlicensed ratings in the deck department. Requirements for sea service, training, professional examination, and physical fitness were incorporated to ensure that the level of qualification for seafarers is uniformly attained in all countries. Additionally, requirements were established in regard to the training of masters, officers and ratings for oil, chemical and liquified gas carriers. These latter provisions were adopted by the conference largely as a result of a resolution adopted by the February 1978 Conference on Tanker Safety and Pollution Prevention (TSPP).

At this point it would be well to review the substance of the requirements of this Convention.

#### APPLICABILITY

Certification of deck officers applies on all vessels over 200 gross registered tons (GRT) and to masters only on vessels under 200 GRT. The requirements for engineer officers applies on vessels with over 750 kilowatts propulsion power.

#### WATCHKEEPING

The principles of watchkeeping are applicable to all ships. The basic principles to be observed in keeping a navigational or engineering watch are defined as follows:

1. Maintain a safe navigational watch;
2. Be particularly concerned to avoid stranding and collision;
3. Establish watch arrangements;
4. All officers shall be fit for duty;
5. The voyage should be planned in advance.



## CERTIFICATION REQUIREMENTS

The mandatory minimum requirements for certification are as follows:

1. Masters and mates must be above a minimum age; pass a written examination; attend a firefighting course; pass a medical examination; and have the stipulated sea service.
2. Chief and second engineer must meet the same types of mandatory minimum requirements as masters and mates as well as the technical knowledge for the type of machinery and propulsion for which they are certified.
3. Watchkeeping officers, both navigation and engineer, must have the same certification required for masters and chiefs except that less in-depth technical knowledge is required. Deck and engineering ratings forming part of a watch must have completed the specified sea service or have successfully undergone special training and have experience or training which includes firefighting, first aid, survival techniques, and personal safety.

## REQUALIFICATION

Masters, deck and engineer officers must also meet the mandatory minimum requirements that ensure continued proficiency and updated knowledge. The administration must be satisfied that officers are medically fit and professionally competent for their approved service. If sea service is inadequate, officers must pass an approved test or course of instruction or undertake service in a supernumerary capacity.

## TRAINING

Officers in charge of a watch must achieve the necessary theoretical knowledge and practical experience through training founded on the basic principles of watchkeeping as noted above and upon the relevant international regulations and recommendations. It is mandatory that firefighting be part of this training. Further, deck officers must demonstrate their proficiency with radar by attendance at an approved course of instruction.

There are mandatory minimum requirements for the training and qualification of masters, officers, and ratings of oil tankers, chemical carriers, and liquified gas tankers. Officers and ratings having specific duties and responsibilities related to cargo and cargo equipment on tankers shall complete a shore-based firefighting course and an appropriate period of supervised shipboard service to acquire knowledge of safe operating practices, or complete an approved familiarization course including safety, pollution prevention, types of tankers and cargoes and their hazards, handling equipment, general operational sequence, and terminology.

Masters, chief engineers, chief mates, and second engineers, in addition to the above requirements, must have relevant experience appropriate to their duties and have completed a specialized training course.

## RESOLUTIONS

The conference also adopted 23 resolutions which reinforce the convention by recommending additional procedures and inviting further development of appropriate training requirements of IMO. The 23 resolutions do not form a part of the convention as they are recommendations only.

Some of the more significant resolutions include:

1. Operational guidance for officers in charge of a navigational watch;
2. Operational guidance for engineer officers in charge of an engineering watch;
3. Recommendations on principles and operational guidance for deck officers and engineer officers tending a watch in port;
4. Basic guidelines and operational guidance relating to safety radio watchkeeping for radio officers and radiotelephone operators;
5. Recommendations on the training and qualifications of officers and ratings on oil tankers.

The resolutions were quite detailed and took up considerably more volume than the basic convention itself. Full justice to all of the detail in the resolutions is not given here because the material contained in the resolutions has enough content for a separate paper in its own right.

## IMPLEMENTATION

The Convention will come into force 12 months after 25 nations, with combined merchant fleets constituting 50 per cent of the gross tonnage of the world's merchant shipping, have either signed without reservation or deposited an instrument of ratification, acceptance, accession or approval. The effect of its benefits may be realized much sooner since many of the more established maritime nations that have already evolved standards comparable to the convention requirements intend to work towards implementing the provisions before the convention comes into force. However, there are many major maritime nations (based on registered tonnage) that do not have a system similar to that prescribed by the convention, or have no system at all. These nations are faced with a major effort to develop and implement a workable system for the issuance and renewal of licenses and certificates for their seafarers.

## TSPF CONFERENCE

During the winter of 1976/77, there occurred a number of tanker accidents off the coast of the United States which resulted in considerable public and governmental concern. The United States Government realized that while the accidents had occurred in United States waters, the problem of tanker safety was an international one. Consequently it turned to IMO when proposing a series of

measures which were designed to improve tanker safety and prevent pollution. IMO responded to this request promptly and agreed to convene a conference in February 1978 to consider the United States proposal and any others that member nations would care to put forward.

The International Conference on Tanker Safety and Pollution Prevention 1978 (TSPP) held in London was the culmination of ten months' work by member nations and the IMO secretariat. The purpose of the conference was to consider proposals that had been developed with a view to improving the International Convention for the Prevention of Pollution from Ships, 1973 (MARPOL 1973). These conventions were in existence but had not yet been implemented internationally. The conference objective was to reinforce these earlier conventions to provide more effective regulatory regimes for oil tankers, particularly in the light of the number of serious tanker accidents which had occurred since the conventions had been adopted. Another purpose was to modify the conventions so as to encourage their acceptance and ratification by Governments and thus help bring the conventions into force on an accelerated basis.

The TSPP Conference adopted two instruments, commonly referred to as the SOLAS Protocol and the MARPOL Protocol. The SOLAS Protocol contains new measures and procedures which supplement SOLAS 1974. The MARPOL Protocol also contains new measures and procedures but incorporates and modifies MARPOL 1973. The conference also adopted 18 resolutions pertaining to the protocols and other related matters.

The two protocols are different in their structure in relation to their parent conventions. Because SOLAS 1974 had been ratified by over half of the number of countries necessary to bring it into force, the protocol was made a separate instrument. Therefore, to bring it into force, the parent convention must be ratified as a prerequisite to ratifying the protocol although both instruments may be ratified simultaneously. Because very few Governments had ratified MARPOL 1973, it was merged into its protocol and became one instrument for ratification purposes.

The SOLAS 1974 Convention brought up to date the regulations for safety of life at sea in light of the amendments thereto adopted in 1966, 1967, 1968, 1969, 1971, 1973, by the Assembly pursuant to the International Convention for the Safety of Life at Sea 1960, and to provide improved as well as accelerated amendment procedures. Upon entry into force, SOLAS 1974 will replace and abrogate SOLAS 1960.

The marine safety measures arising out of TSPP include inert gas systems for protection of cargo tanks, steering gear requirements, radar and collision avoidance aids and strengthened inspection and certification requirements. Where design features and fitting of equipment are required for new oil tankers, these are defined by the following dates:

1. Tankers which have a contract date after 1 June 1979, or in the absence of a building contract;
2. Tankers which have their keel laid after 1 January 1980; or
3. Tankers which are delivered after 1 June 1982.

Tankers which do not conform to the above criteria are defined as existing ships.

## INERT GAS SYSTEMS

SOLAS 1974 required inert gas systems to be fitted in new oil tankers over 100,000 DWT and in new combination carriers over 50,000 DWT. The SOLAS Protocol extends the inert gas system requirements to:

1. All new tankers over 20,000 DWT;
2. All existing crude oil carriers over 20,000 DWT and all existing product carriers over 40,000 DWT;
3. All existing tankers of 20,000 DWT and above, where high capacity washing machines are fitted (60 cubic metres per hour or greater);
4. All tankers where crude oil washing is fitted.

Inert gas systems are required within two years of the SOLAS Protocol coming into force for tankers of 70,000 DWT and above, and a further period of two more years for crude oil carriers of 20,000 DWT and above, and product carriers of 40,000 DWT and above.

## STEERING GEAR

SOLAS 1974 contained requirements for steering gear for both passenger and cargo vessels. ISPP formulated special requirements for tankers, which are contained in the protocol. These include:

1. All tankers of 10,000 gross tons and above must have two remote steering gear control systems, each operable separately from the navigating bridge.
2. The main steering gear of new tankers of 10,000 GRT and above, must be comprised of two or more identical power units, and be capable of operating the rudder while operating with one or more power units. Ships so equipped must also have an alarm on the navigating bridge to warn of system failure and an alternative power supply that will start automatically within 45 seconds of a failure.

The above requirements must be implemented within two years of the date of entry of the protocol for existing tankers.

The conference also formulated special requirements relating to control, communication, and local operation and testing of steering gear at stipulated intervals. These requirements apply to both new and existing tankers.

The conference also formulated special requirements relating to control, communication, and local operation of steering gear as well as procedures and drills covering the operation and testing of steering gear at stipulated intervals. These requirements apply to both new and existing tankers.

## RADARS

The conference agreed that all ships between 1,600 GRT and 10,000 GRT be fitted with radar, while all ships above 10,000 GRT and above must be fitted with two radars, each capable of independent operation. These ships must be so equipped on the day the SOLAS Protocol comes into force.

## INSPECTION AND CERTIFICATION

One of the major issues and the more significant development of the TSPC Conference was the area of inspection and certification. The requirements contained in SOLAS 1974 were strengthened and additional requirements were formulated. The main changes in substance were:

1. In addition to the periodic surveys specified in SOLAS 1974, administrations must institute unscheduled inspections of all ships unless mandatory annual surveys are carried out. These inspections shall ensure that the ship and all of its equipment remain in all respects satisfactory for its intended service. The administrations are obliged to fully guarantee the completeness and efficiency of these inspections and surveys and to make the necessary practical arrangements to satisfy this obligation.
2. New procedures were developed which must be followed when defects are found during unscheduled inspections. In brief, they require that the designated surveyor or inspecting organization ensure that corrective action is taken.
3. Administrations will be required to provide a clearer definition of the authority they delegate to non-governmental bodies to act on their behalf. As a minimum, any nominated surveyor or recognized organization shall be empowered to require repairs to a ship and carry out inspections and surveys if requested by the authorities of a port State.
4. SOLAS 1974 requires surveys for safety equipment certificates to be carried out every two years. A requirement for an annual survey for tankers of ten years of age or over was added.
5. SOLAS 1974 does not specify a period of validity for Cargo Ship Safety Construction Certificates. Under the SOLAS Protocol, these certificates are valid up to a maximum period of five years. There is also a requirement for an intermediate Cargo Ship Safety Construction Certificate survey for tankers of ten years of age or over.
6. The Cargo Ship Safety Construction Certificate survey requirements have been extended to include cargo pumping, piping, and venting arrangements.
7. The obligation to maintain ships and their equipment in a satisfactory condition between surveys has been more clearly defined.
8. More explicit requirements for reporting accidents and deficiencies and the manner in which administrations are required to act on this information were adopted.

Corresponding additions and modifications were incorporated into the MARPOL Protocol; in particular, no extension of the five-year period of validity of the International Oil Pollution Prevention Certificate is permitted.

## RESOLUTIONS

The TSPP Conference also adopted eighteen resolutions covering a wide range of topics which supplement the requirements of the protocols and give direction to the future work of IMO. A summary of those resolutions which are marine-safety-oriented are as follows:

1. A target date for entry into force of SOLAS 1974 and its 1978 protocol was set at June 1979. Governments were to ensure that the provisions of the protocol were applied to new and existing tankers according to the dates established. Governments were invited to put into effect the requirements for inert gas systems on existing tankers of 70,000 DWT and above by June 1981; on existing tankers of 20,000-40,000 DWT and those of 20,000 DWT and above fitted with high capacity washing machines by June 1983; and the requirements for steering gear for existing tankers by June 1981.
2. IMO is to study the requirements relating to inert gas systems in regulation 62 of chapter 11-2 of SOLAS 1974 and develop guidelines to supplement those requirements.
3. Governments were urged to implement the procedures as set out in resolution A321(IX) adopted in 1975 for the control of ships in respect of the 1960 SOLAS Convention and the 1966 Load Lines Convention. IMO was invited to develop these guidelines and procedures further.
4. The critical importance of the human factor in the safe operation of ships was pointed out and IMO was invited to bring the attention of the 1978 International Conference on Training and Certification of Seafarers to the need for adoption of provisions concerning the adequate training and certification of tanker crews.
5. Both protocols provide for modifications to provisions relating to intervals of surveys and inspections and in particular allow for the introduction of unscheduled inspections or mandatory annual surveys. The resolution recognizes that the efficiency of such procedures depends upon the rules promulgated by National Administrations. At present there are different time periods of validity for certificates issued under the SOLAS, MARPOL, and Load Lines Conventions. The resolution invites IMO to take early action to standardize the periods of inspection and certification as well as developing guidelines for the extent, frequency, and particulars of periodic and intermediate inspections and surveys.
6. It was recognized that many countries found it difficult to ensure the complete observance of these international standards due to a shortage of trained marine safety experts. They recognized fully that their universal observance was essential for the protection of their own maritime interests, including the marine environment. IMO was therefore requested to formulate arrangements for making advice and assistance available by the establishment of a marine safety corps consisting of a team of experts in various marine disciplines.

7. The changes to the technical provisions of SOLAS 1974 concerning improved steering gear standards apply only to tankers of 10,000 GRT and above. Improved steering gear arrangements for cargo and passenger vessels are contained in resolution A325(IX) adopted by the organization in 1975. These are in the form of recommendations only and do not have the mandatory effect of convention requirements. IMO was therefore requested, as a matter of urgency, to redraft the steering gear standards for cargo and passenger vessels in resolution A325(IX), taking into account the provisions of the SOLAS Protocol. IMO was also requested to study the need for making the requirements in the SOLAS Protocol, which apply to tankers only, also applicable to other ships and to consider the adoption of the improved steering gear standards together with other provisions for machinery and electrical installations as amendments to chapter II-1 of SOLAS 1974 upon its entry into force. This action would give such standards the desired mandatory effect.
8. IMO was called upon to develop performance standards for collision avoidance aids (CAA) as a matter of urgency and to prepare requirements for the carriage of such aids on all ships of 10,000 GRT and upwards. CAA are electronic systems or devices which add to or enhance the information available from conventional radars. They are intended to assist the navigating officer in assessing the risk of collision and the suitability of any manoeuvre to avoid collision.

#### IMPLEMENTATION

The procedural arrangements for bringing the SOLAS Convention and its Protocol and the MARPOL Protocol into force were based on the need to ensure that their safety and pollution prevention requirements were implemented at the earliest possible time. The SOLAS 1974 Protocol will come into force six months after being accepted by 15 nations whose combined fleets total at least 50 per cent of the world's gross tonnage of merchant shipping. The conference recommended a target date of June 1979 for entry into force of SOLAS 1974. Its protocol should be ratified at the same time as the parent convention or as soon as possible thereafter. The MARPOL Convention was merged into its protocol and, because of technical problems with annex II of the parent convention, the conference agreed to delay for three years the coming into force of annex II after the coming into force of the MARPOL Protocol. The protocol will come into force a year after being accepted by 15 nations whose combined fleets total at least 50 per cent of the world's gross tonnage. The target date for coming into force of the MARPOL Protocol is June 1981.

#### CODES OF SAFETY

International conferences are rather momentous occasions in an organization like IMO. They receive a lot of attention and deservedly so, but IMO's marine safety activities are not confined to conferences and conventions. There are many subcommittees and working groups of experts within the technical committee structure of IMO which are developing other instruments of international consensus which do not have such a broad and sweeping scope as a convention, but are applied to a specific ship type or service or a marine technical discipline area. These

instruments are technical codes which have the status of recommendations. Several of these codes have been developed in recent years and have been adopted or are under consideration for adoption. These include the Code for the Construction and Equipment of Ships Carrying Dangerous Chemicals in Bulk, Code for the Construction and Equipment of Ships Carrying Liquified Gases, and the Code of Safety for Nuclear Merchant Ships. Both the bulk chemical code and the gas carrier code have been adopted by the Assembly and have been issued. These codes are at present in the form of recommendations and are not binding internationally, although a number of nations have implemented their provisions. The Nuclear Merchant Ship Code has been cleared at the working group level and is passing through the various levels of hierarchy leading to review and adoption by the Assembly.

These technical codes are alike in that they have a specific application and are very detailed in their requirements for design, construction, equipment operation, and maintenance of these particular types of vessels.

There is a consideration within IMO to make both the bulk chemical code and the gas carrier code mandatory under SOLAS 1974. This would be in the form of an amendment to that Convention. However, work remains in the harmonization of the two codes, and attention must be given to procedural matters in the way of implementation. Work is in progress towards this end.

#### OTHER MARINE SAFETY ACTIVITIES

Further down in the scale of marine safety activities comes the work of individual technical sub-committees or working groups which is generally confined to a particular discipline or a specific technological application. All of this work provides a broad base of expertise upon which larger activities can draw while individual problems can be studied in detail and resolved.

For example, the Subcommittee on Fire Protection has completed a set of guidelines on inert gas systems for oil tankers as was called for in resolution 5 of the ISPP Conference. These have been approved by the Maritime Safety Committee and, as directed by the Assembly, they are being printed and circulated to all the Governments concerned. The other part of that resolution which called for a re-examination of regulation 62 of chapter 11-2 of SOLAS 1974 has also been accomplished, a revised text for that regulation has been adopted and Governments are being urged to implement the revised regulation.

These guidelines include a discussion of the physical principles of inert gas systems, their function, design, and operation. Specific application requirements for cargo tank operations on both product carriers and combination carriers are given with sections on emergency procedures, maintenance and testing, training of operating personnel, instruction manuals, and safety considerations. All in all, a very comprehensive treatment of this subject.

Another activity related to the ISPP Conference was the development of a set of performance standards for automatic radar plotting aid by the Sub-committee on Safety of Navigation. This was in response to the ISPP resolution calling for performance standards of collision avoidance aids. This set of standards was approved by the Maritime Safety Committee and sent to the Assembly in resolution form.



The Subcommittee on Ship Design and Equipment is also working in the area of steering gear systems and is making progress towards meeting the complex recommendations that came out of the ISPP Conference resolution for steering gear.

Still another activity of the Navigation Subcommittee is the development of traffic separation schemes. In the region of interest to this workshop are those in the Strait of Hormuz, Tunb-Farur, and in the approaches to Ras Tanura and Ju'aymah. A fourth traffic separation scheme was approved for off Ras Al Hadd by the Maritime Safety Committee in November of 1979 and became effective in February 1980.

The procedure of the introduction of traffic separation schemes has been simplified and is contained in resolution A376(X) and resolution A377(X). Briefly, adjacent maritime States can introduce a scheme which is reviewed by the Subcommittee on Navigation and when approved by the Maritime Safety Committee, becomes effective four months after the date of adoption. The schemes must meet the requirements of resolution A373(X) and vessel operation within the scheme is governed by rule 10 of the International Regulations for Preventing Collisions at Sea, 1972.

The activities mentioned here are but a few of the numerous and diverse technical areas which are under study, review, amendment, or development. Other areas include such things as basic requirements in stability, vessel manoeuvrability, fire protection, and life-saving appliances. The whole spectrum of marine safety interests is in the hands of the groups of marine safety experts to ensure that the instruments of international co-operation are the most responsive to international needs and are at the forefront of available technology.

#### STATUS

The instruments which reflect IMO marine safety activities have been described in some detail above. These instruments, when implemented, will have an impact on the global problems of marine safety and marine pollution that are extant today. There should be a significant reduction in both the rate and severity of marine casualties and their attendant pollution problems. The timetable for the coming into force of these instruments has been indicated and it is noted that these timetables for ratification are quite ambitious. This reflects the intensity of purpose of the participants at those Conferences and of the member nations of the IMO Assembly. The concern is also carried over into the revised procedures within IMO to streamline revisions and implementation of recommendations.

The actual ratification process for the conventions and protocols has not been quite on schedule, but considering that these instruments will require the major overhaul of some nations' maritime safety organizations or the creation of others which had not previously existed, the implementation has been relatively expeditious. The SOLAS 1974 Convention came into force on 25 May, 1980. The SOLAS 1974 Protocol has been ratified by 14 countries with over 49 per cent of the world's total merchant ship tonnage. Another signature should bring it into force. The MARPOL 1973 Protocol, which was adopted with the MARPOL 1973 Convention, has been ratified by seven countries. Unfortunately, STCW 1978 has not fared nearly as well, having been ratified by only one country to date.

The amendment procedures to these basic documents have been streamlined over the more cumbersome procedures of the past, so that future amendments and revisions can be made in a more timely fashion. But, in order to implement these newer procedures, the basic instruments must be ratified and come into force.

IMO AND ITS ACTIVITIES WITH PARTICULAR REFERENCE TO THE PREVENTION  
AND CONTROL OF MARINE POLLUTION

by  
J. Wonham

International Maritime Organization,  
London, England, U.K.

ABSTRACT

The object of the paper is to give a comprehensive summary of IMO's responsibility within the UN system for the prevention and control of pollution from ships. In global terms, ships discharge a greater proportion of oil during routine operations that occurs as a result of accidental spillages. This is reflected in the greater emphasis given to the development of the International Convention for the Prevention of Pollution from Ships. The work programme of the Marine Environment Protection Committee consists of concentrated efforts on the specification of equipment requirements relating to improved pollution prevention measures in tankers such as oil discharge monitoring and control systems, crude oil washing, and segregated ballast tanks. However, active consideration is being given by the MEPC to improving capabilities for responding to major oil spillages, principally in the publication of a comprehensive anti-pollution manual. In the development of regional arrangements for oil spill response, IMO has, for example, been involved in the establishment of the Marine Emergency Mutual Aid Centre in the Kuwait Action Plan Area. IMO's ongoing technical assistance programme is also described. This includes the conduct of seminars, symposia and workshops in cooperation with UNEP, UNDP and the Swedish International Development Agency.

## OBJECTIVES, FUNCTIONS AND STRUCTURE OF IMO

### Objectives and functions

The International Maritime Organization is a specialized agency of the United Nations whose activities are entirely in the maritime field. The Organization's objectives, as provided for in article 1 of its Convention (as amended in 1975) are, inter alia, to provide machinery for co-operation among Governments in the field of governmental regulations and practices relating to technical matters of all kinds affecting shipping engaged in international trade, to encourage the general adoption of the highest practicable standards in matters concerning maritime safety and efficiency of navigation and the prevention and control of marine pollution from ships, and to deal with legal matters related thereto.

One of the important functions of IMO is to provide for the drafting of conventions, agreements or other suitable instruments, and to convene conferences to adopt such instruments. At present there are 31 conventions and similar instruments for which IMO performs depositary or secretariat functions.

Of these, 11 conventions and instruments relate to the prevention and control of marine pollution, a list of which is attached as annex I. Conventions relating to maritime safety also contribute to the prevention of accidental pollution.

In addition, there are a number of codes, recommendations and guidelines, many of which relate to the prevention and control of operational and accidental pollution.

### Membership

IMO is open to membership by all States Members of the United Nations and by the other States in accordance with the admission procedures contained in the IMO Convention. There are at present 125 full members of the Organization and one associate member, which include practically all nations in the world interested in maritime affairs.

### Principal Organs of IMO

The following are the principal organs of IMO:

- Assembly
- Council
- Maritime Safety Committee (MSC)
- Marine Environment Protection Committee (MEPC)
- Legal Committee
- Facilitation Committee
- Committee on Technical Co-operation

The Assembly is the supreme governing body of the Organization. It determines the policy of the Organization, decides upon the work programme and votes the budget to which members of the Organizations contribute. It recommends to member States

the adoption of regulations concerning maritime safety and prevention and control of marine pollution. The Assembly is composed of all States members of IMO and normally meets once every two years.

The Council consists of member States elected by the Assembly for a term of two years. Subject to the authority of the Assembly, it supervises the execution of the work programme of the Organization and performs the functions of the Governing Body between sessions of the Assembly.

The Maritime Safety Committee (MSC) is open to all IMO member States. It is responsible for the technical work of the Organization, concerning in particular maritime safety and efficiency of navigation. It performs its functions mainly with the assistance of sub-committees and other subsidiary bodies which are also generally open to participation by all States members of the Organization.

At present there are 11 subsidiary bodies of the Maritime Safety Committee, as follows:

- Sub-Committee on Safety of Navigation (NAV)
- Sub-Committee on Radiocommunications (COM)
- Sub-Committee on Life-Saving Appliances (LSA)
- Sub-Committee on Standards of Training and Watchkeeping (STW)
- Sub-Committee on the Carriage of Dangerous goods (CDG)
- Sub-Committee on Containers and Cargoes (BC)
- Sub-Committee on Fire Protection (FP)
- Sub-Committee on Ship Design and Equipment (DE)
- Sub-Committee on Subdivision, Stability and Load Lines (STAB)
- Sub-Committee on Safety of Fishing Vessels (SFV)
- Sub-Committee on Bulk Chemicals (BCH) (which is a subsidiary body of MSC and MEPC)

The work programme of the Organization relating to maritime safety and efficiency of navigation is performed by the Maritime Safety Committee and its subsidiary bodies in accordance with the provisions of the IMO Convention. A list of the main items to be dealt with by the subsidiary bodies of MSC is attached as annex II.

The Marine Environment Protection Committee (MEPC) is a permanent subsidiary organ of the Assembly, established by resolution A.297(VIII) (copy attached as annex III). Membership is open to all States members of IMO as well as to States which are parties to the conventions in respect of which the Committee performs functions. It is responsible for administering and co-ordinating the activities of IMO relating to the prevention and control of marine pollution from ships, vessels and other equipment operating in the marine environment. The work of the MEPC is summarized later in this paper.

The Legal Committee is a subsidiary body of the Council and is charged with the consideration of legal matters of concern to the Organization. The Legal Committee is open to participation by all States members of IMO.

The Facilitation Committee is a subsidiary body of the Council established to advise the Council on matters relating to the facilitation of maritime traffic. It also provides advice to the Secretary-General of the Organization in relation to his functions under the Convention for the Facilitation of International Maritime Traffic, 1965. Membership of this Committee is open to all members of IMO as well as to States parties to the Facilitation Convention.

The Committee on Technical Co-operation is a subsidiary body of the Council and performs advisory functions in respect of IMO's programme of technical assistance to developing countries. Membership of the Committee is open to all States members of IMO.

In addition, IMO provides secretariat services for Consultative Meetings of Contracting Parties to the Convention on the Prevention of Marine Pollution by Dumping of Wastes and Other Matter (LDC).

It should be noted that most of the conventions and other instruments referred to earlier contain provisions which call upon IMO organs to perform functions in relation to such instruments. For instance, the IMO Assembly, MSC or MEPC is designated as an organ to adopt amendments to the relevant convention. Thus there is a close link between the activities of the IMO organs and the administration of conventions.

#### Functions and responsibility of the secretariat

The main functions and responsibility of the secretariat are to provide services to carry out the work programme of the Organization, which include the following:

- (1) to provide the normal secretariat and other facilities required in preparation for conferences, meetings of IMO bodies and other meetings convened by IMO and for the work of those meetings. These facilities include, in particular, the provision of background documentation and conference facilities of all kinds;
- (2) to organize the necessary follow-up action arising from the work of these meetings;
- (3) to perform depositary and other functions conferred upon the Secretary-General in respect of conventions and other instruments;
- (4) to provide appropriate information and services to Governments in connection with consequential action necessary to implement decisions or recommendations by, or arising from the work of IMO organs, bodies and conferences;
- (5) to participate in the work of international organizations outside IMO, including representation at meetings and conferences convened by such organizations;
- (6) to organize symposia, seminars and training courses and carry out other programmes to further the objective of the Organization;

- (7) to organize and execute the technical co-operation programme either by securing and co-ordinating contribution of experts, and donor agencies and Governments or, where necessary or appropriate, by providing the required technical, legal or administrative expertise to Governments and institutions.

#### SCOPE OF THE WORK OF IMO IN THE FIELD OF PREVENTION AND CONTROL OF MARINE POLLUTION

The work programme of IMO in the field of marine environment protection is directed towards the following:

- (1) to develop and adopt the highest practicable standards for the prevention and control of operational and accidental pollution from ships and other equipment operating in the marine environment;
- (2) to encourage Governments in the effective implementation and enforcement of internationally accepted standards and other related measures;
- (3) to promote co-operation among Governments, particularly at regional level, for combating pollution in cases of emergencies;
- (4) to provide assistance to developing countries in order to meet the objectives of IMO mentioned in (2) and (3) above.

In the following sections are brief descriptions of the international conventions in this field developed and deposited with IMO, or for which IMO is performing secretariat functions, and work being carried out by the MEPC and other bodies for the prevention and control of marine pollution.

#### INTERNATIONAL CONVENTIONS RELATING TO MARINE POLLUTION

International Convention for the Prevention of Pollution of the Sea by Oil, 1954, as amended in 1962 and 1969

The first major step towards the international control of marine pollution was taken in 1954 when a conference held in London adopted the International Convention for the Prevention of Pollution of the Sea by Oil. The Convention was provisionally deposited with the United Kingdom Government until IMO was established in 1959, when the depositary functions were taken over by the Organization. The principal object of the 1954 Convention was the protection of the seas from oil pollution, which was achieved by prescribing certain "prohibited zones" extending to at least 50 miles from the nearest land, within which the discharge of oil or oily mixtures (containing 100 parts of oil per million parts of mixture or more) was prohibited.

In 1962 IMO convened a Conference which adopted amendments to the 1954 Convention, particularly by extending its application to include ships of lesser gross tonnage and by extending the zones in which the discharge of oil was prohibited.

In 1969 the IMO Assembly adopted further extensive amendments which prohibit oil discharge through the normal operation of a ship, except under the following conditions:

- (1) the total quantity of oil which a tanker may discharge in any ballast voyage must not exceed 1/15,000 of the total cargo carrying capacity of the vessel;
- (2) the rate at which oil may be discharged must not exceed 60 litres per mile travelled by the ship; and
- (3) no discharge of any oil whatsoever must be made from the cargo spaces of a tanker within 50 miles of the nearest land.

The 1969 Amendments provide for a new form of oil record book which is designed to show the movement of cargo oil and its residues from loading to discharging on a tank to tank basis. These amendments should considerably reduce the overall total quantity of oil discharged into the sea and achieve significant progress towards the ultimate goal of complete elimination of operational oil pollution.

The 1969 Amendments to the 1954 Convention entered into force on 20 January 1978 for its 64 parties. The combined tanker fleet of 52 parties to the Convention covers more than 88 per cent by number, and 94 per cent by gross tonnage of the world oil tanker tonnage.

In 1971, the IMO Assembly adopted two further amendments to the Convention. One of the amendments is aimed at providing special protection for the Great Barrier Reef area, in view of its unique scientific and environmental significance, by regarding the area as if it were a part of the land. The other one concerns tank arrangement and limitation of the size of individual tanks of a tanker, aimed at minimizing the amount of oil which could escape as a result of maritime accidents, particularly those involving very large tankers.

Although the 1971 Amendments have not formally entered into force, it has been recommended that they be put into effect nationally and they are observed in several maritime countries.

#### International Convention for the Prevention of Pollution from Ships, 1973

Notwithstanding the foregoing action by IMO to deal with oil pollution, far-reaching developments in modern industrial practices have introduced the need for further action on a much larger scale and considerably broader in scope than has been required hitherto. This situation was recognized by the IMO Assembly when, in 1969, it decided to convene an international conference for the purpose of preparing a suitable international agreement for placing restraints on the contamination of the sea, land and air by ships, vessels and other equipment operating in the marine environment.

The international conference, which met in London in October 1973, adopted a new International Convention for the Prevention of Pollution from Ships, 1973, which is not yet in force, to replace the 1954 Oil Pollution Convention.

The new Convention covers all the technical aspects of pollution from ships, except disposal of land-generated waste into the sea by dumping. It applies to ships of all types including hydrofoil boats, air-cushion vehicles, submersibles,

floating craft, and fixed or floating platforms operating in the marine environment. The Convention does not, however, apply to pollution directly arising out of the exploration and exploitation of sea-bed mineral resources.

The Convention consists of articles, two protocols dealing respectively with reports on incidents involving harmful substances and arbitration, and five annexes which contain regulations for the prevention of:

- (1) pollution by oil;
- (2) pollution by noxious liquid substances carried in bulk;
- (3) pollution by harmful substances carried in packages, portable tanks, freight containers, or road or rail tank wagons etc.;
- (4) pollution by sewage from ships; and
- (5) pollution by garbage from ships.

The main provisions of the 1973 Convention, \*supplemented as appropriate by the related decisions of the Conference, are summarized in the following paragraphs.

#### Prevention of pollution by oil (annex I)

The Convention maintains the oil discharge criteria prescribed in the 1969 Amendments to the 1954 Oil Pollution Convention, without substantial changes, except that the maximum quantity of oil which is permitted to be discharged in a ballast voyage of new oil tankers has been reduced from 1/15,000 on the cargo capacity to 1/30,000 of the amount of cargo carried. These criteria apply equally both to persistent (black) and non-persistent (white) oils. A new and important feature of the 1973 Convention is the concept of "special areas". Specified areas considered to be particularly vulnerable to pollution by oil have been designated as "special areas" in which oil discharges have been completely prohibited, with minor and well defined exceptions. The main special areas in the Convention are the Mediterranean Sea Area, the Black Sea Area, the Baltic Sea Area, the Red Sea area and the Kuwait Action Plan Region.

All oil-carrying ships will be required to be capable of operating with the method of retention on board in association with the "load-on-top" system or discharge to reception facilities. To effect this, all new and existing oil tankers and other ships will, with certain exceptions, be required to be fitted with appropriate equipment, which will include an oil discharge monitoring and control system, oily water separating equipment or filtering system, slop tanks, sludge tanks, piping and pumping arrangements.

With regard to the constructional aspects of oil tankers, two important provisions have been incorporated in the 1973 Convention. Firstly, new oil tankers, i.e. those for which the building contract is placed after 31 December 1975, of 70,000 tons deadweight and above, will be required to meet subdivision and damage stability requirements so that they can survive after collision or stranding damage whatever the load conditions.

---

\* Provisions of the 1973 Convention, in particular those of annex I, have been modified by the Protocol of 1978 (see section on "International Conference on Tanker Safety and Pollution Prevention, 1978" below.)



## Control of pollution by noxious liquid substances (annex II)

The Convention sets out detailed requirements for the discharge criteria and measures for control of pollution by noxious liquid substances carried in bulk. For this purpose noxious liquid substances are divided into four categories depending upon their hazard to marine resources, human health, amenities and other legitimate uses of the sea. Some 250 substances have been evaluated and included in the list appended to the Convention and additional substances are being evaluated as a continuing task with a view to updating the Convention when it has entered into force. The discharge of residues containing such substances is allowed only to reception facilities, until certain concentrations and conditions, which vary with the category of substances, are complied with. In any case no discharge of residues containing noxious substances is permitted within 12 miles from the nearest land in a depth of water of less than 25 metres. The Baltic Sea Area and Black Sea Area are designated as special areas in which stricter restrictions are applied for the discharge of noxious liquid substances.

With regard to the design, construction, equipment and operation of chemical tankers, the Government of each Party is obliged to issue detailed requirements which contain at least all the provisions of the Code for the Construction and Equipment of Ships Carrying Dangerous Chemicals in Bulk (IMO Assembly resolution A.212(VII), as amended).

Prevention of pollution by harmful substances carried in packaged form, or in freight containers or portable tanks or road and rail tank wagons (annex III).

The Convention contains general requirements relating to the prevention of pollution by harmful substances carried by sea in packaged form or in freight containers, portable tanks or road and rail tank wagons. Detailed requirements on packaging, marking and labelling documentation, stowage, quantity limitations and other aspects aimed at preventing or minimizing pollution of the marine environment by such substances have been developed and circulated among the Governments (MEPC/Circ.50 of 14 July 1977) and updated (MEPC/Circ.78 of 19 September 1979). It is recommended that the Circular be used as guidelines in interim measures to protect the marine environment from pollution by this form of transport of goods. This circular, together with experience gained, will form the basis for future revision of the International Maritime Dangerous Goods Code to cover the pollution aspects.

Prevention of pollution by sewage and garbage (annexes IV and V)

Ships will not be permitted to discharge sewage within four miles from the nearest land unless they have in operation an approved treatment plant; between four and twelve miles from land, sewage must be comminuted and disinfected before discharge. The Organization has formulated effluent standards, which sewage treatment plants should achieve for discharge within these limits, and guidelines for test procedures for approval of such plants by Administrations (resolution MEPC.2(VI)).

As regards garbage, specific minimum distances from land have been set for the disposal of all the principal kinds of garbage. The disposal of all plastics is prohibited.

International Conference on Tanker Safety and Pollution  
Prevention, 1978

In March 1977 the United States, after a series of tanker accidents in or near United States coastal waters in the winter of 1976/77, requested IMO to take international action to improve tanker safety and pollution prevention. After intensive preparation by its technical bodies, IMO convened, in February 1978, the International Conference on Tanker Safety and Pollution Prevention (TSPP). The Conference adopted the Protocol of 1978 relating to the International Convention for the Safety of Life at Sea, 1974 (SOLAS Protocol) and the Protocol of 1978 relating to the International Convention for the Prevention of Pollution from Ships, 1973 (MARPOL Protocol).

The SOLAS Protocol contains in its annex requirements for improved steering gear control systems, the carriage of second radar for all ships of 10,000 gross register tons and above, and inert gas systems (IGS) for tankers of 20,000 tons deadweight and above, with the exception of certain existing tankers of less than 40,000 tons deadweight.

The MARPOL Protocol, which is merged with the original Convention and should be read and interpreted together with that Convention as a single instrument, will enable the Governments to accept and implement the provisions of annex I to the Convention, as modified by the Protocol, by deferring the implementation of annex II for a period of three years. Certain technical problems related to annex II, which have made it difficult for Governments to accept the Convention, are expected to be resolved in those three years of grace.

The annex to the MARPOL Protocol contains provisions inter alia requiring oil tankers to operate with segregated ballast tanks (SBT), dedicated clean ballast tanks (CBT) and/or crude oil washing systems (COW) as follows:

- (1) all new crude oil tankers of 20,000 tons deadweight and above must be fitted with protectively located SBT and COW;
- (2) all new product oil carriers of 30,000 tons deadweight and above must be provided with protectively located SBT;
- (3) all existing crude oil tankers of 40,000 tons deadweight and above must be provided with SBT, CBT or COW;
- (4) all existing product carriers of 40,000 tons deadweight and above must be provided with SBT or CBT.

CBT referred to in (3) and (4) above is a system whereby appropriate cargo tanks are designated for the carriage of clean ballast only and is recognized as an interim measure for existing tankers of 70,000 tons deadweight and above for two years after the entry into force of the Protocol and for four years for those of between 40,000 and 70,000 tons deadweight.

The SOLAS and MARPOL Protocols define a "new oil tanker" for the purposes of the implementation of SBT, CBT, COW, IGS and steering gear requirements, as an oil tanker to which any of the following dates apply:

- Contract placed after 1 June 1979;
- Keel laid after 1 January 1980;
- Delivery after 1 June 1982;

except that the definition of "new ship" in regulation 1(6) of annex I of the MARPOL Convention remains unchanged for the application of SBT requirements to new oil tankers of 70,000 dwt and above. Both Protocols lay down more stringent inspection, survey and certification requirements for oil tankers, in particular those of 10 years of age and over.

The Conference also adopted a number of resolutions, including two which set target dates for the entry into force of the 1974 SOLAS Convention (June 1979),\*\* the SOLAS Protocol (same time as the entry into force of the Convention or as soon as possible thereafter) and the MARPOL Convention and Protocol (June 1981).

In order to make the technical implications of the Protocols widely known, a technical seminar on TSPP was held at IMO headquarters in London from 16-17 October 1978. Also, to make the outcome of the TSPP Conference and the International Conference on Training and Certification of Seafarers fully understood by all countries concerned, regional seminars for Asia were held in Japan in February 1979, for Latin America in January 1980 and for Africa in early 1981. A booklet entitled "The International Conference on Tanker Safety and Pollution prevention" was also prepared and distributed among the member States and interested organizations. The booklet sets out the provisions of the SOLAS and MARPOL Protocols in non-technical terms and is provided with many illustrations and explanatory diagrams.

#### Legal Conventions

In 1967 the IMO Council recognized that the Torrey Canyon disaster had also brought to light new problems of pollution control which were essentially legal in character. The Council therefore established a Legal Committee with the mandate of studying and recommending action on all the legal problems brought to light by the disaster.

As a result of the Legal Committee's work, two International Legal Conferences were convened by IMO in Brussels, Belgium in November 1969 and December 1971. These Conferences adopted three International Conventions:

- (1) The International Convention relating to Intervention on the High Seas in Cases of Oil Pollution Casualties (Public Law). This concerns the extent to which a State, directly threatened or affected by a casualty which takes place outside its territorial sea, can take measures to protect its coastline, harbours, territorial sea or amenities;
- (2) The International Convention on Civil Liability for Oil Pollution Damage (Private Law). This provides for the liability, subject to certain conditions, of a shipowner for pollution damage resulting from an incident in which his ship is involved up to a limit of US \$169 per ton or US \$17.8 million, whichever is the lesser;
- (3) The International Convention on the Establishment of an International Fund for Compensation for Oil Pollution Damage. This Convention supplements the Liability Convention and provides for the compensation of victims of oil pollution damage beyond the limit of the shipowners' liability. The

---

\*\* The 1974 SOLAS Convention entered into force on 25 May 1980; MARPOL 73/73 is due to enter into force on 2 October 1983.

Fund's obligations are, however, limited, so that the total amount payable to victims shall not exceed US \$57.1 million\*\*\* for any one incident.

The Intervention Convention and the Civil Liability Convention entered into force on 6 May 1975 and 19 June 1975 respectively and the Fund Convention entered into force on 16 October 1978.

In 1976, parties to the Civil Liability and Fund Conventions adopted Protocols to these Conventions which replace the limits of compensation specified in gold Poincaré francs by Special Drawing rights as defined by the International Monetary Fund.

#### WORK PROGRAMME OF THE MARINE ENVIRONMENT PROTECTION COMMITTEE

Within its terms of reference and with a view to implementing the decisions and recommendations of the 1973 Marine Pollution Conference, the Marine Environment Protection Committee (MEPC), at its first session (4-3 March 1974), agreed on an Action Plan which includes an indication of appropriate priorities for conducting its work. The Action Plan has been reviewed in the light of progress made and such new developments as the TSPP Conference and the Amoco Cadiz disaster. The current progress and future plans for dealing with some of the principal items of interest are described in the following paragraphs.

Interpretation of and amendments to the provisions of the 1973 MARPOL Convention as modified by the Protocol of 1973 thereto (MARPOL 73/78)

The MEPC is reviewing various points of interpretation of the provisions of MARPOL 73/78 which may require clarification or give rise to difficulties in implementation and for which it would be desirable to develop a uniform and authoritative interpretation or consider a future amendment.

In 1982, the Organization published the text of annex I of MARPOL 73/78 together with agreed amendments and unified interpretations adopted by the MEPC. This text provides an up-to-date reference to the MARPOL requirements for those concerned in government administration, shipping and ship building industries and other related activities. The publication is entitled "Regulations for the Prevention of Pollution by Oil" (IMO ref. No. 525 32.19.E ISBN 92-801-1148-5).

#### Reception facilities for residues

Under the respective annexes of the MARPOL 73/78 Convention, parties accept a general obligation to ensure the provision and maintenance of adequate facilities in ports for the reception of residues from oil, noxious chemical substances, sewage and garbage. Certain additional obligations apply to parties in respect of special areas as designated in the Convention. With regard to oil pollution, for example, annex I of the Convention requires that the Governments of parties the coastlines of which border on the Mediterranean Sea, the Black Sea or the Baltic Sea areas, shall ensure that, not later than 1 January 1977, reception facilities are provided in all oil loading terminals and repair ports in the area. These must be adequate for the

---

\*\*\* The original limit of 450 million francs or 38 million US dollars was increased to 675 million francs or 57.1 million dollars by a decision of the second Fund Assembly in April 1979.

reception and treatment of all the dirty ballast and tank washing water from oil tankers as well as other oily mixtures or residues from all ships. Similar requirements will also be applied in other special areas, such as the Red Sea area and the Kuwait Action Plan Region, as from a date to be established by the Organization at the appropriate time.

With a view to assisting Governments concerned in meeting this obligation, the Organization prepared Guidelines on ensuring the Provision and Maintenance of adequate Reception Facilities in Ports on the basis of studies carried out in several countries on the technological, economic and other implications of the Convention requirements in this respect. Part I of these Guidelines relating to oil, Part II relating to noxious liquid substances and Part III on sewage and garbage, were published in 1977, 1980 and 1978 respectively.

#### Oil discharge monitoring and control system

Annex I of MARPOL 73/78 requires that tankers and other vessels shall be fitted with oil discharge monitoring and control systems approved by the Administration concerned. To facilitate compliance with this requirement the Organization is collecting information on the availability of such equipment not only with respect to persistent oils but also for use with a wide range of light refined oils which fall within the definition of "oil" as set out in the Convention.

In 1971 the Organization developed a Recommendation on International Performance Specifications for Oily Water Separating Equipment and Oil Content Meters (resolution A.233(VII)). In the light of experience gained since its adoption and to provide for the new requirements contained in the 1973 Convention, this specification was revised and adopted by the tenth Assembly of the Organization (resolution A.393(X)). In November 1979 the eleventh Assembly of the Organization adopted a recommendation concerning the installation of oily-water separating equipment under the International Convention for the Prevention of Pollution from Ships, 1973 as modified by the Protocol of 1978 relating thereto (resolution A.444(XI)). In November 1981 the twelfth Assembly adopted Guidelines and Specifications for Oil Discharge Monitoring and Control Systems for Oil Tankers (resolution A.496(XII)) which allows for varying implementation requirements depending on size and date of construction of tankers).

Work being carried out under this item includes collection of information on approved equipment, development of guidelines for approval by Governments of oil discharge monitoring and control systems, specifications for an oil/water interface detector, etc.

#### Crude Oil Washing (COW) and Clean Ballast Tank (CBT) Specification and Operation Manuals

In response to resolution 15 of the TSPP Conference, MEPC has reviewed the Specification for the Design, Operation and Control of Crude Oil Washing System. The Revised Specifications, which were adopted by the Assembly in November 1979, incorporate amendments prepared in the light of experience gained since the TSPP Conference and agreed interpretation of some of the provisions.

Every ship operating with crude oil washing is required to carry a COW Operations and Equipment Manual developed and approved for that ship. As the purpose of the Operations and Equipment Manual is not only to provide guidance to the crew of the ship but also to provide information on the system and its operational procedures for inspectors going on board for inspection in ports, the MEPC developed a standard format for the manual specifying the information to be

contained in 17 sections of the Manual (resolution MEPC.39(XII)) adopted on 30 November 1979).

The Revised Specifications and the Standard Format, together with Specimen Manuals and the Guidelines for In-port Inspection of Crude Oil Washing have subsequently been published by IMO in one volume (IMO ref. No. 619.92.04.E ISBN 92-801-1133-7).

Similarly the MEPC has revised the Specifications for Oil Tankers with Dedicated Clean Ballast Tanks contained in TSP resolution 14 and has developed a standard format for the CBT Operations Manual. These were adopted by the twelfth Assembly (resolution A.495(XII)) in November 1981 and have been published by the Organization (IMO ref. No. 619.92.11.E ISBN 92-801-1139-6).

#### Reporting systems

As one of the lessons learned from the Amoco Cadiz disaster, various IMO bodies are considering legal and technical problems involved in imposing obligations on masters to report to the authorities of the flag State, the coastal States (within a certain distance from the ship) and the classification society concerned in circumstances in which the safe and efficient navigation of the ship is impaired by reasons of damage.

The MEPC has recommended that all member States should establish a pollution reporting system as laid down in protocol I of the 1973 MARPOL Convention without waiting for the entry into force of the Convention. The MEPC has developed Interim Guidelines for reporting Incidents Involving Harmful Substances, which were adopted by the IMO Assembly in November 1979 (resolution A.447(XI)).

#### Enforcement of convention provisions

The Organization is considering ways and means of assisting Governments in detecting infringements of Convention requirements and improving enforcement of the provisions. These include the development of:

- (1) improved arrangements for the inspection of tankers at oil loading terminals and repair ports in order to ascertain whether residues have been discharged at sea in breach of the Convention; and
- (2) a standard method of identification of the source of discharged oil by such means as "tagging" cargoes with certain identifiable materials, and improved methods and analysis of oily water mixtures.

With regard to (1) above, the tenth Assembly of IMO adopted a Resolution on Procedures for the Control of Discharges under the International Convention for the Prevention of Pollution of the Sea by oil, 1954 (as amended in 1962 and 1969), setting out guidelines for the enforcement of the Convention (resolution A.391(X)). The MEPC has recognized the need to update the control procedures prior to the entry into force of the 1973 MARPOL Convention as modified by the Protocol, 1978 (target date June 1981). In view of the complexity of the problems involved it was agreed that the first step, the draft control procedure, should be limited to ships and certification and to control of discharge of oil.

#### Evidence of violation

Article X(1) of the International Convention for the Prevention of Pollution of the Sea by Oil, 1954, as amended in 1962 and 1969, provides procedures for furnishing to flag States information about contraventions of the Convention so that the flag States could take legal proceedings against the owner or master of the ship. Experience has shown, however, that the information furnished by the coastal or port States is often insufficient to enable the flag State to cause proceedings. The MEPC has therefore developed "Guidelines for Coastal and Port States for Reporting to Flag States on Alleged Contraventions of the International Convention for the Prevention of Pollution of the Sea by Oil, 1954, as amended in 1962 and 1969" (See report of the fourteenth session of the Committee (MEPC XIV/11. Annex 10) for the text). The Guidelines identify information which is often needed by the flag State for the prosecution of such alleged contravention and are supplementary to the Procedures for the Control of Discharges referred to above.

#### Comprehensive manual on oil pollution

MEPC has been engaged in the preparation of a comprehensive manual on oil pollution with a view to providing guidelines to assist Governments, particularly those of developing countries, in establishing national marine pollution control programmes. The Manual will comprise five sections:

- I. Prevention of oil pollution from ships
- II. Contingency planning for combating oil spills
- III. Salvage of oil from ships
- IV. Practical information on means of dealing with oil spills
- V. Legal aspects

Sections I, II and the revised and updated version of section IV were published in 1976, 1978 and 1980 respectively. Section III has subsequently been published in 1983. Section I of the Manual has been revised and re-published in 1983 to include technical details of pollution prevention arrangements of ships while at berth and during ship-to-ship transfer and changes consequent to the entry into force of MARPOL 73/78. The Organization has also published Guidelines developed jointly by IMO and UNEP on Oil Spill Dispersant Application and Environmental Considerations (IMO ref. No. 575.82.18.E).

Also under consideration by MEPC is the widening of the scope of the Manual to include a section on practical information on means of dealing with spillages of harmful chemicals.

#### Survey and certification

Resolution 10 of the TSPP Conference called upon IMO to develop guidelines for Administrations, as to the extent, particulars and frequency of intermediate surveys and inspections of ships having due regard to their construction, machinery, equipment and age, and also containing requirements for the frequency and scope of unscheduled inspections and the scope of mandatory annual surveys conducted in lieu of unscheduled inspections.

In response to the above, guidelines on mandatory annual surveys, unscheduled inspections, intermediate surveys of all ships under annex I of the MARPOL Protocol

are being developed by the MEPC. Similar Guidelines under the SOLAS Convention and Protocol have been developed by the Maritime Safety Committee and adopted by the eleventh Assembly of the Organization (resolution A.413(XI)).

#### The Sub-Committee on Bulk Chemicals

The Sub-Committee on Bulk Chemicals was established in 1976 as a subsidiary body of both the Marine Environment Protection Committee and the Maritime Safety Committee to deal with the problems associated with the bulk carriage of chemicals. Its principal function is to consider problems relating to transport of chemicals in bulk, including those relating to annex II of the 1973 Convention. The Sub-Committee's work programme in the marine environment protection includes the following:

- Standards for procedures and arrangements for the discharge of noxious liquid substances required by regulation 3 of annex II of the MARPOL Convention;
- Hazard evaluation of noxious substances on the basis of advice from GESAMP (see below) and review and updating of the lists of substances contained in annex II of MARPOL 73/78 and the annex to the 1973 Intervention Protocol;
- Review of the Code for the Construction and Equipment of Ships Carrying Dangerous Chemicals in Bulk to ensure that marine pollution aspects are fully covered and are consistent with the provisions of the MARPOL Convention;
- Carriage of MARPOL annex I and annex II substances simultaneously on a ship and mixtures of annex I and annex II substances.

#### Work relating to GESAMP

IMO, together with FAO, UNESCO, WMO, WHO, IAEA, the United Nations and UNEP, is a sponsoring agency of the Joint Group of Experts on the Scientific Aspects of Marine Pollution (GESAMP). This Group, for which IMO provides the Administrative Secretary and a Technical Secretary, is a multi-disciplinary body composed of independent experts which considers various scientific matters upon which the sponsoring agencies require expert advice.\*\*\*\* At the request of IMO, GESAMP has provided such advice on numerous questions, including, in particular:

- the development of a rationale for evaluating the hazards of harmful substances carried by ships;
- the continuing task of evaluating those substances in accordance with the rationale;
- the development of guidelines for identifying particularly sensitive sea areas including the factors to be taken into account in such identification.

---

\*\*\*\* The results of work and the outcome of considerations of GESAMP are published in REPORTS AND STUDIES which are available upon request from the IMO Technical Secretary of GESAMP.



## REGIONAL ARRANGEMENTS FOR DEALING WITH MARINE POLLUTION EMERGENCIES

In order to prepare for marine pollution emergencies, each country should establish a national contingency plan and provide adequate manpower equipment and material for combating pollution. The MEPC recognized that regional anti-pollution arrangements are a valuable and economical way of supplementing national arrangements in the effective combating of major spillages of oil and other harmful substances. Resolution A.448(XI) adopted by the Assembly urges Governments to develop or improve national contingency arrangements and develop joint contingency arrangements at a regional/subregional level, if they have not already done so.

IMO has co-operated with UNEP in regional seas programmes, in particular in developing regional co-operation in combating marine pollution as follows.

### The Mediterranean

The Conference of Plenipotentiaries of the Coastal States of the Mediterranean Region on the Protection of the Mediterranean Sea, which took place in Barcelona in February 1976, adopted the following instruments:

- Convention for the Protection of the Mediterranean Sea against Pollution;
- Protocol for the Prevention of Pollution of the Mediterranean Sea by dumping from Ships and Aircraft;
- Protocol concerning Co-operation in Combating Pollution of the Mediterranean Sea by Oil and other Harmful Substances in Cases of Emergency.

The Conference also decided to establish a regional oil combating centre in Malta, and requested the Executive Director of UNEP, after consultation with the Government of Malta and IMO, to assist in this undertaking. IMO was entrusted with the functions and responsibilities as Co-operating Agency for the establishment and operation of this Centre for which an appropriate project document was agreed by IMO and UNEP. Accordingly IMO established the Centre in December 1976, the initial objectives of which are:

- to strengthen the capacities of the coastal States of the area and to facilitate co-operation among them in order to combat massive pollution by oil, especially in cases of emergencies;
- to assist coastal States in the development of their own national capabilities to combat oil pollution and to facilitate information exchange, technological co-operation and training.

With the above objectives in view, the Malta Centre is engaged in:

- collection and dissemination of information;
- preparation and keeping up-to-date of emergency plans for combating oil pollution;
- development of communication/information system; and
- development and encouragement of technological co-operation in training.

Notable activities of the Centre include the organization, in co-operation with Governments of the region, of training courses on oil pollution prevention and control. The Centre has also provided financial assistance to send participants from the Mediterranean coastal States to training courses taking place outside of the region. An IMO/UNEP Workshop on Oil Pollution Contingency Planning for the Mediterranean Sea was held at the Centre in September 1978. The Centre maintains inventories of oil pollution equipment and expertise and publishes a News letter where by national focal points are regulars, updated on trends and development.

Common coastal region of Oman, United Arab Emirates, Qatar, Bahrain, Saudi Arabia, Iraq and Iran

IMO also participated in the preparatory work for the Kuwait Regional Conference of Plenipotentiaries on the Protection and Development of the Marine Environment, which was held in Kuwait from 15-24 April 1978, and adopted an Action Plan relating to the Region and the following legal instruments:

- Kuwait Regional Convention for Co-operation on the Protection of the Marine Environment from Pollution; and
- Protocol concerning Co-operation in Combating Pollution by Oil and other Harmful Substances in Cases of Emergency.

The Conference also agreed to establish a fund to implement the Action Plan.

A substantial contribution has been made by the Organization particularly in the preparation of the above-mentioned Protocol and concerning the proposed development of a Marine Emergencies Mutual Aid Centre to be established thereunder.

The Gulf of Guinea

IMO has co-operated with UNEP in the development of a draft action plan and in preparing a draft legal instrument for regional co-operation in combating marine pollution in cases of emergency in the Gulf of Guinea. The draft Action Plan for the region was finalized at a Meeting of Government Experts in Libreville, Gabon, 5 to 10 November 1979. The Meeting recommended that a regional convention should be drawn up, together with a protocol on emergency co-operation. A meeting of legal experts was convened during 1980 to finalize the draft convention and protocol in readiness for the Plenipotentiary Conference held in March 1981. IMO prepared the first draft of the protocol, and also implemented an Oil Pollution Overview Study for the Region.

Red Sea

Coastal pollution surveys have been conducted by IMO for Saudi Arabia (FIT agreement with the Saudi Arabian Government), Egypt and Jordan (FIT agreement with ALECSO). Further surveys are projected for Sudan and N. Yemen and it is expected that liaison will shortly be re-established with ALECSO concerning detailed arrangements. Following the convening of a Meeting of Experts to follow up the recommendations of the Jeddah II Conference (January 1976), including finalization of the Jeddah Convention and its Protocols, a Plenipotentiary Conference was held in Jeddah early in 1982 at which the action plan and regional legal instruments were adopted.

E. Asian Waters

The regional seas programme is confined to the sea area of the five ASEAN

countries (Indonesia, Malaysia, Philippines, Singapore and Thailand). A Meeting of Government Experts to consider an action plan for the region took place from 16 to 20 June 1980 in Baguio, Philippines. The outcome of the IMO/UNEP Meeting in Jakarta, 7 to 9 January 1980 concerning the development of sub-regional oil-spill contingency arrangements in the Celebes (Sulawesi) Sea was reported to the Baguio Meeting, together with progress on the IMO/UNEP project on toxicity of oil dispersant chemicals on tropical and sub-tropical species (Philippines) and progress with the International Workshop on the prevention, abatement and combating of pollution from ships which was held in the Philippines in November 1980. (Preparation for the Workshop included the preparation of an Oil Pollution Overview Study for the Region, which is expected to be completed by early 1981.)

#### Caribbean

Long-term plans for the Wider Caribbean have followed on from the UNEP Meeting of Government Experts which took place in Caracas in January 1980. However, in the immediate future, IMO's main involvement is with the OAS/IMO/UNEP initiative to develop Oil-spill Contingency Plans for the Island countries of the Caribbean. As a first stage, IMO's Inter-Regional Marine Pollution consultant conducted a study (jointly with the OAS) on the special problems of the smaller island countries, the outcome of which was discussed at a Meeting of Government Representatives at Puerto Rico, 16 to 20 June 1980. This Meeting was followed by a meeting in Barbados in December 1980 at which all the island countries were invited to attend.

#### S. E. Pacific

UNEP will execute its programme in this region in co-operation with the Permanent Commission for the South Pacific (CPPS). The action plan has involved the conduct of an IMO/UNEP Workshop on the Combating of Marine Pollution from Ships and the development of regional contingency plans.

#### S. W. Pacific

Informal discussions have been held with UNEP concerning IMO's involvement in the programme, which is most likely to take the form of the development of regional arrangements for combating pollution arising from emergencies. It is felt that in the immediate future, contacts with such bodies as South Pacific (SPC) and the South Pacific Economic Commission (SPEC) should be utilized at every opportunity so as to impress upon established regional organizations the benefits which may accrue from having established regional or sub-regional contingency arrangements which can be activated in the event of a major oil spillage.

### TECHNICAL ASSISTANCE TO DEVELOPING COUNTRIES

Measures for preventing, controlling and combating pollution from ships involve complex technical problems which are often beyond the capabilities of developing countries to resolve. For this reason, IMO has attached great importance to the promotion of technical assistance to developing countries in the field of marine pollution. The IMO Assembly in 1975 affirmed the desirability of continuing to enhance the activity of the Organization in the field of technical assistance on marine pollution. Such technical assistance activity is pursued by:

- the implementation of national and regional technical assistance programmes with financial support by the United Nations Development Programme (UNDP),

the United Nations Environment Programme (UNEP) or national aid organizations, as appropriate;

- the utilization by States seeking advice of the expertise available among the member States; and
- consultation among Governments within the relevant organs of IMO, such as MEPC, in order to study the ways and means of promoting technical co-operation.

Major problems which have been identified as requiring technical assistance include:

- (1) implementation of the 1959 Amendments to the 1954 Oil Pollution Convention and of the 1973 Marine Pollution Convention as modified by the 1978 Protocol, particularly on the provision of reception facilities;
- (2) contingency planning for combating spillages, including regional or subregional arrangements;
- (3) methods of dealing with spillages, including the availability of equipment and materials;
- (4) training of personnel;
- (5) prevention of maritime accidents, including traffic separation schemes and provision of aids to navigation.

With regard to (1) above, courses for Maritime Administrators on Prevention of Pollution from Ships were held from 8-19 August 1977, from 7-19 August 1978 at the Merchant Marine Academy, Malmö, Sweden, with the financial assistance of the Swedish International Development Authority. The purpose of the courses was to identify problems encountered in the implementation and administration of the 1973 Convention and to inform them of the experience of Baltic Sea countries in solving these problems. Seventeen participants from 13 IMO member States took part in the first course, 14 participants from 14 members States in the second course and 19 participants from 18 IMO member States took part in the third course.

With regard to (2) above, the Malta Centre (see section on the Mediterranean in the chapter on Regional Arrangements for dealing with Marine Pollution Emergencies, above) organized a regional contingency planning seminar on the subject from 4-7 September 1978. With regard to (3) above, an IMO/UNEP International Workshop on Prevention, Combating and Abatement of Pollution from Ships in the Gulf of Guinea and Adjacent Coastal Areas was held in Douala, Cameroon, 12-16 December 1977. A similar workshop was held in Cartagena, Colombia from 23-27 October 1978 for participants from Caribbean countries.

A number of technical assistance programmes have been pursued or are planned by IMO in response to the requests by developing countries, and these include the following:

- (1) technical advice by IMO experts on combating spillages following maritime accidents, such as Metula, St. Peter, etc.;
- (2) expert missions to individual countries to assist in resolving problems involved in the implementation of conventions relating to marine pollution, in developing national legislation, administrative arrangements and contingency planning;

- (3) development of regional arrangements for co-operation to combat pollution in cases of emergency;
- (4) technical workshops, training courses and study programmes relating to prevention and control of marine pollution;
- (5) introduction of pollution prevention and abatement courses into training programmes of existing and planned maritime academies.

#### PREVENTION OF MARINE POLLUTION BY DUMPING OF WASTES AND OTHER MATTER

In 1972, the Convention on the Prevention of Marine Pollution by Dumping of Wastes and Other Matter, was adopted by the Inter-Governmental Conference on the Dumping of Wastes at Sea, convened in London by the Government of the United Kingdom.

The Convention, generally known as the London Dumping Convention, provides for control of "any deliberate disposal at sea of wastes or other matter from vessels, aircraft, platform or other man-made structures at sea" and any deliberate disposal of such vessels, aircraft, etc. themselves. The prevention of marine pollution emanating from the normal operations of vessels, aircraft, etc., or directly arising from the exploration and exploitation of sea-bed mineral resources, is excluded from the scope of the Convention.

The London Dumping Convention entered into force on 30 August 1975 and in December 1975 IMO was designated as the organization responsible for the secretariat duties.

Since its designation as the organization responsible for the secretariat duties in relation to the London Dumping Convention, IMO has convened annual Consultative Meetings of Contracting Parties. At these Consultative Meetings the contracting parties have taken action on several very substantive matters arising from the Convention, such as the development of notification procedures related to the issue of permits for dumping, records of the type and quantities of wastes and other matter actually dumped, monitoring activities and the dumping of materials in emergency situations. The consultative meetings further developed procedures for the implementation of technical assistance and co-operation relating to the disposal of wastes at sea. The contracting parties, at their meetings, made considerable progress in the implementation of many items of their Action Plan established at the First Consultative Meeting, including the following:

- (1) the development of specific procedures to control incineration at sea which have been included in annexes I and II of the Convention; these amendments were adopted by the Third Consultative Meeting in 1978; the Fourth Consultative Meeting in 1979 adopted technical guidelines on incineration;
- (2) the adoption of amendments to the Convention concerning procedures for the settlement of disputes with respect to interpretation and application of the Convention;
- (3) the development of guidelines on the interpretation of the terms "trace contaminants" and "rapidly rendered harmless", which include a consultation procedure and recommend certain biological tests;

- (4) the development of general guidelines for classification of substances in annexes I and II to the Convention; and
- (5) the consideration of Provisional Definition and Recommendations concerning the Dumping of Radioactive Wastes and Other Matter which have been prepared by the International Atomic Energy Agency (IAEA).

Other work which had to be carried out for the implementation of the Convention includes the definition and interpretation of terms such as "trace contaminants", "rapidly rendered harmless" and "significant amounts" (e.g. of hazardous substances which require special care if contained in wastes intended to be dumped).

For providing scientific advice and for the preparation of proposals and drafts concerning the procedures mentioned above, the First Consultative Meeting has established the Ad Hoc Scientific Group on Dumping. Advice on specific topics had been given to the consultative meetings by the following two advisory groups:

- (1) the Ad Hoc Group on Incineration at Sea; and
- (2) the Ad Hoc Group of Legal Experts on Dumping.

Considerable work related to scientific aspects of dumping has also been carried out by GESAMP.

The work currently under consideration by the Ad Hoc Scientific Group on Dumping includes the following:

- (1) the review of substances listed in annexes I and II to the Convention (black and grey lists);
- (2) the review of criteria to be considered when permits on dumping are issued as set out in annex III to the Convention;
- (3) the development of procedures for the exchange of new land-based treatment techniques which may prevent or mitigate pollution caused by dumping; and
- (4) the development of guidelines on monitoring the condition of the sea for the purposes of the London Dumping Convention.

During the course of discussions, contracting parties have further recognized that many questions on dumping are also related closely to the activities of not only other IMO bodies but several other international organizations. With this in view, close co-operation has been established with organizations dealing with the prevention of marine pollution, such as UNEP, the Oslo Commission and the Paris Commission.

Annex I

LIST OF STATES WHICH HAVE ACCEPTED CONVENTIONS RELATING TO MARINE POLLUTION IN RESPECT OF WHICH IMO PERFORMS DEPOSITARY OR SECRETARIAT FUNCTIONS (as at 9 December 1982)

	1954 OILPOL (Amended 1962 and 1969)	Amend- ments		1973 MARPOL	1978 MARPOL PROTOCOL *	1969 INTERVENTION	1973 INTERVENTION PROTOCOL	1969 CIVIL LIABILITY	1971 FUND	1972 DUMPING	Amendments		
		1971 (Great Barrier Reef)	1971 (Tanks)								1978 (Incineration)	1978 (Settlement of Disputes)	1980 (List of Substances)
Afghanistan										X	X		X
Algeria	X	X	X					X	X				
Argentina	X									X	X		X
Australia	X	X	X										
Austria	X												
Bahamas	X	X	X			X	X	X	X				
Bangladesh	X					X							
Belgium	X					X	X	X					
Brazil								X		X	X		X
Bulgaria	X												
Byelorussian SSR										X	X		X
Canada	X	X	X							X	X	X	X
Cape Verde										X	X		X
Chile	X							X		X	X		X
China								X					
Colombia				X	X								
Cuba						X				X	X		X
Cyprus	X												
Democratic Yemen	X												

\* Parties to the 1978 MARPOL Protocol undertake to give effect also to the provisions of the 1973 MARPOL Convention subject to the modifications and additions set out in the Protocol.

	1954 OILPOL (Amended 1962 and 1969)	Amend- ments		1973 MARPOL	1978 MARPOL PROTOCOL *	1969 INTERVENTION	1973 INTERVENTION PROTOCOL	1969 CIVIL LIABILITY	1971 FUND	1972 DUMPING	Amendments		
		1971 (Great Barrier Reef)	1971 (Tanks)								1978 (Incineration)	1978 (Settlement of Disputes)	1980 (List of Substances)
Denmark	X	X	X		X	X		X	X	X	X	X	X
Dominican Republic	X					X		X		X	X		X
Ecuador						X		X					
Egypt	X												
Fiji	X					X		X					
Finland	X	X	X			X		X	X	X	X		X
France	X	X			X	X		X	X	X	X	X	X
Gabon						X		X	X	X	X		X
German Democratic Republic	X	X	X			X		X		X	X		X
Germany, Federal Republic of	X	X		X	X	X		X	X	X			
Ghana	X					X		X	X				
Greece	X	X	X		X			X		X	X		X
Guatemala										X	X		X
Guinea	X												
Haiti										X	X		X
Hungary										X	X		X
Iceland	X					X		X	X	X	X		X
India	X												
Indonesia								X	X				
Ireland	X					X				X	X		X
Israel	X												
Italy	X	X	X	X	X	X	X	X	X				
Ivory Coast	X		X					X					

\* See footnote on page 1.



	1954 OILPOL (Amended 1962 and 1969)	Amendments		1973 MARPOL	1978 MARPOL PROTOCOL *	1969 INTERVENTION	1973 INTERVENTION PROTOCOL	1969 CIVIL LIABILITY	1971 FUND	1972 DUMPING	Amendments		
		1971 (Great Barrier Reef)	1971 (Tanks)								1978 (Incineration)	1978 (Settlement of Disputes)	1980 (List of Substances)
Japan	X					X		X	X	X	X	X	
Jordan	X	X	X	X						X	X		X
Kenya	X			X						X	X		X
Kiribati										X	X		X
Kuwait	X					X		X	X				
Lebanon	X	X	X			X		X					
Liberia	X	X	X		X	X	X	X	X				
Libyan Arab Jamahiriya	X									X	X		X
Madagascar	X												
Maldives	X							X	X				
Malta	X	X	X										
Mexico	X					X	X			X	X		X
Monaco	X					X		X	X	X	X		X
Morocco	X					X		X		X	X		X
Nauru										X	X		X
Netherlands	X					X	X	X	X	X	X	X	X
New Zealand	X	X				X		X		X			X
Nigeria	X							X		X	X		X
Norway	X	X	X	X	X	X	X	X	X	X	X		X
Panama	X					X		X		X	X		X
Papua New Guinea	X					X		X	X	X	X		X
Peru				X	X								
Philippines	X	X	X							X	X		X
Poland	X					X	X	X		X	X		X
Portugal	X					X		X		X	X		X

\* See footnote on page 1.

	1954 OILPOL (Amended 1962 and 1969)	Amend- ments		1973 MARPOL	1978 MARPOL PROTOCOL *	1969 INTERVENTION	1973 INTERVENTION PROTOCOL	1969 CIVIL LIABILITY	1971 FUND	1972 DUMPING	Amendments		
		1971 (Great Barrier Reef)	1971 (Tanks)								1978 (Incineration)	1978 (Settlement of Disputes)	1980 (List of Substances)
Qatar	X												
Republic of Korea	X							X					
Saudi Arabia	X	X	X										
Senegal	X					X		X					
Singapore								X					
South Africa								X		X	X		X
Spain	X					X		X	X	X	X		X
Suriname	X					X				X	X		X
Sweden	X	X	X		X	X	X	X	X	X	X	X	X
Switzerland	X	X	X							X	X		X
Syrian Arab Republic	X	X	X			X		X	X				
Tunisia	X	X	X	X	X	X	X	X	X	X	X		X
Tuvalu								X	X				
Ukrainian SSR										X	X		X
United Arab Emirates										X	X		X
USSR	X	X	X			X		X		X	X		X
United Kingdom	X	X	X	X	X	X	X	X	X	X	X	X	X
United States	X				X	X	X			X	X	X	X
Uruguay	X	X	X	X	X								
Venezuela	X												
Yemen	X			X		X	X	X					
Yugoslavia	X		X	X	X	X	X	X	X	X	X		X
Zaire										X	X		X

\* See footnote on page 1.

SUMMARY OF THE PRESENT STATUS OF THE ABOVE CONVENTIONS  
AT 9 DECEMBER 1982

	1954 OILPOL (Amended 1962 and 1969)	Amend- ments		1973 MARPOL	1978 MARPOL PROTOCOL	1969 INTERVENTION	1973 INTERVENTION PROTOCOL	1969 CIVIL LIABILITY	1971 FUND	1972 DUMPING (Amended 1978)	Amendments		
		1971 (Great Barrier Reef)	1971 (Tanks)								1978 (Incineration)	1978 (Settlement of Disputes)	1980 (List of Substances)
Number of signatures	20	-	-	16	12	31	10	28	17	-	-	-	-
Number of ratifications, acceptances, approvals or accessions	68	26	25	12	15	42	14	49	26	52	50	8	50
Number of ratifications, etc. necessary for entry into force	-	46	46	15	-	-	15	-	-	-	-	34	-
Number of IMO Members having ratified, etc. the instrument	66	26	25	12	15	40	14	45	24	44	42	8	42
Number of non-IMO Members having ratified, etc. the instrument	2	0	0	0	0	2	0	4	2	8	8	0	8
Number of IMO Members not having ratified, etc. the instrument	56	96	96	110	107	82	108	77	98	78	80	114	80

Annex II

MAIN ITEMS OF THE WORK PROGRAMMES OF MSC SUB-COMMITTEES

Safety of navigation

- Routing of ships: adoption of new traffic separation schemes, amendments and updating of procedures
- Ship movement reporting systems
- Performance standards for navigational aids and related equipment, equipment reliability
- Review of the 1972 Collision Regulations
- Matters concerning search and rescue, including follow-up of the International Conference on Search and Rescue, 1979
- Guidelines on bridge design and layout

Standards of training and watchkeeping

Follow-up of the International Conference on Training and Certification of Seafarers (14 June to 7 July 1979), in particular:

- Training and certification of crews of fishing vessels (in co-operation with the Sub-Committee on Safety of Fishing Vessels)
- Training, qualification and operational procedures for maritime pilots
- Manning of sea-going ships
- Training and qualifications of crews on mobile off-shore units

Life-saving appliances

- Preparation of a complete revision of chapter III of the 1974 Safety Convention
- Preparation of a Code of Practice for the evaluation of new types and prototype tests of life-saving appliances and arrangements
- Survival in cold water

Radiocommunications

- Development of the Maritime Distress System
- Operational Standards for shipborne radio equipment

- International co-ordination of promulgating navigational warnings for shipping
- Preparation for the Mobile World Administrative Radio Conference, 1982
- Preparation for CCIR Study Group 9
- Life-saving radio equipment
- Ship reporting format and procedures

#### Carriage of dangerous goods

- International Maritime Dangerous Goods Code; adoption, implementation and amendments; inclusion of pollutants therein (updating of MRPC/Circ. 79)
- Emergency procedures for ships carrying dangerous goods
- Portable tanks and road tank vehicles for dangerous goods
- Revision of the "Medical First Aid Guide for Use in Accidents involving Dangerous Goods"

#### Containers and cargoes

- International Convention for Safe Containers, interpretations, implementation procedures and amendments
- Code of Safe Practice for Bulk Cargoes; amendments and updating; inclusion of pollutants; carriage of solid dangerous substances in bulk
- Code of Safe practice for Ships carrying Timber Deck Cargoes, amendments and implementation
- Carriage of grain; dispensation from trimming requirements; standards of trimming; securing of grain surfaces; strength of grain fittings

#### Bulk chemicals

- Updating of the Bulk Chemical code and Gas Carrier Code
- Carriage of bulk chemicals in deep tanks of dry cargo ships
- Handling of liquid chemicals and liquefied gases in bulk in ports

#### Ship design and equipment

- Safety measures for special purpose ships
- Review of the Code of Safety for nuclear merchant ships
- Requirements for manoeuvrability of ships

- Safety measures for diving systems
- Noise and vibration levels aboard ships
- Review of Dynamically Supported Vessel Code
- Review of Mobile Off-shore Drilling Unit Code

#### Subdivision, stability and load lines

- Improved intact stability criteria
- Subdivision and damage stability of dry cargo ships including roll-on/roll-off ships
- Harmonization of subdivision and stability requirements in various Conventions and Codes
- Improvement of the 1966 Load Line Convention

#### Fire protection

- Fire safety measures for ships carrying dangerous goods, roll-on/roll-off ships, special purpose ships, ships carrying chemicals in bulk and liquefied gases
- Safety measures for tankers against fire and/or explosion, including inert gas systems
- Formulation of fire test procedures

#### Safety of fishing vessels

- Stability of fishing vessels
- Review of guidelines for the design, construction and equipment of small fishing vessels
- Collection and analysis of casualty records and intact stability calculations, especially for decked fishing vessels of less than 24 metres in length.

Annex III

RESOLUTION A.297(VIII)

Adopted on 23 November 1973

ESTABLISHMENT OF A MARINE ENVIRONMENT PROTECTION COMMITTEE

THE ASSEMBLY,

TAKING NOTE of Article 1 of the IMO Convention regarding the purposes of the Organization.

BEING AWARE of the increasing extent and importance of the activities of the Organization relative to the prevention of pollution of the land, sea or air by or from ships, vessels and other crafts operating in the marine environment (hereafter referred to as ships),

TAKING ACCOUNT of the recommendations of the United Nations Conference on the Human Environment (Stockholm, 5-16 June 1972), of the preparation for the Third Law of the Sea Conference and of relevant Resolutions adopted by the United Nations and also of the role of the United Nations Environment Programme established by Resolution 2997 (XXVII) of the General Assembly,

RECOGNIZING that in the environmental field, activities of the Organization are becoming increasingly involved with related activities of other United Nations bodies and organizations and that the Organization is being called upon to play a more significant role in this field,

NOTING with appreciation that the principal burden arising from responsibilities of the Organization for dealing with marine pollution from ships has hitherto been carried by the Maritime Safety Committee in addition to its important and extensive statutory obligations relative to the safety of life and property at sea,

BELIEVING nevertheless that overall efficiency of the Organization will be greatly enhanced in the future if matters relating to the protection of the marine environment are undertaken by a body specifically assigned for this purpose, thus enabling the Maritime Safety Committee to concentrate more especially on the work relating to maritime safety which is also increasing in importance and magnitude,

HAVING NOTED the outcome of the IMO Conference on Marine Pollution (London, 8 October - 2 November 1973), particularly with respect to the conclusion of the International Conventions for the Prevention of Pollution from Ships, 1973 and the adoption of associated Conference Resolutions,

HAVING CONSIDERED the Recommendations of the Council and its Ad Hoc Working Group on Marine Environment Protection with respect to the future role and activities of the Organization in this field,

NOTING Articles 12 and 16(c) of the IMO Convention concerning the establishment of subsidiary bodies,

RECOGNIZING that the objectives will be most effectively and efficiently achieved by the establishment of a permanent Committee to execute and co-ordinate all activities of the Organizations relating to the prevention and control of pollution of the marine environment from ships.

DECIDES to establish a Marine Environment Protection Committee as a pertinent subsidiary body of the Assembly pursuant to Article 16(c) of the IMO Convention, with the following Terms of Reference:

"To assist IMO in its consultations with other bodies within the United Nations system, especially the United Nations Environment Programme, and with other international organizations and expert bodies in the field of marine pollution, and to co-ordinate and administer, in consultation as appropriate with other bodies of IMO, the activities of the Organization concerning the prevention and control of marine pollution from ships and in particular:

- (a) to perform such functions as are or may be conferred upon the Organization under international conventions for the prevention and control of pollution from ships, particularly with respect to the adoption or amendment of regulations or other provisions, as provided for in such conventions;
- (b) to consider appropriate measures to facilitate the enforcement of the Conventions referred to in paragraph (a) above;
- (c) to provide for the acquisition and dissemination of scientific, technical and any other practical information on the prevention and control of marine pollution from ships to States, particularly developing countries, and, where appropriate, to make recommendations and to develop guidelines;
- (d) to promote co-operation with regional organizations concerned with the prevention of marine pollution from ships;
- (e) to consider and take appropriate action with respect to any other matters falling within the scope of the Organization which would contribute to the prevention and control of marine pollution from ships including co-operation on environmental matters with other international organizations."

DECIDE FURTHER that:

- (a) Membership of the Committee shall be open to all States Members of the Organization and to other States Parties to Conventions in respect of which the Committee performs functions, provided that a State not a Member of the Organization may vote only when the Committee performs functions in respect of a Convention to which it is a party as provided in that Convention. However, the adoption of amendments to a Convention shall be in accordance with the procedures set forth in the Convention under consideration;
- (b) the Committee shall, except as specifically provided otherwise in its Terms of Reference, for example paragraph (a) thereof, report to the Assembly through the Council. The Council shall transmit reports of the Committee to the Assembly, together with its own comments and recommendations. As regards budgetary and other organizational matters, the Council shall exercise the same function and control as it does over other sectors of the Organization's work;



- (c) the Committee shall follow the Rules of Procedures of Assembly except in so far as the Committee with approval of the Assembly, adopts other rules. The Committee is empowered to adopt and apply its own rules in relation to the following subjects: sessions, credentials, publicity, agenda, election of officers, summary records and languages. The quorum for the meetings of the Committee shall be determined by the Committee itself.

REQUESTS the Secretary-General to take all necessary steps for the inauguration of the Committee early in 1974,

REQUESTS the Council, the Maritime Safety Committee and the Legal Committee to provide all possible assistance and co-operation with the work of the Committee.

Annex IV

INTERNATIONAL MARITIME ORGANIZATION

ORGANIZATIONAL CHART 1984/85

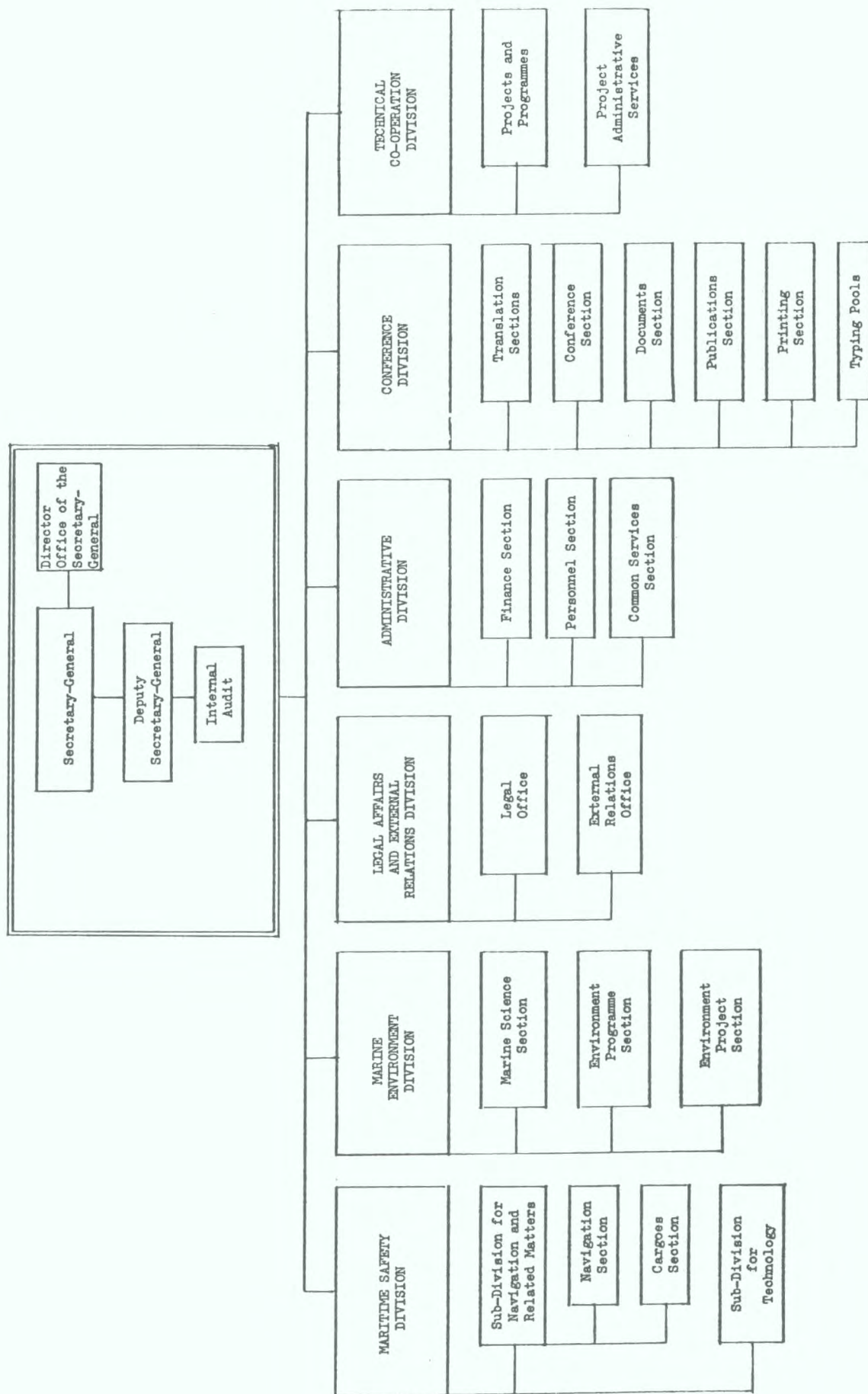

POLLUTION IN THE SHIPPING INDUSTRY

- PREVENTION IS BETTER THAN CURE

by  
T. P. Hebden

The Bahrain Petroleum Company Limited,  
Sitra, Bahrain

ABSTRACT

The only certain method of controlling pollution is to prevent its occurrence. The National Academy of Science report, based on 1973 figures, estimated that 6.1 million tonnes of oil entered the seas each year, and of this 35 per cent came from ship sources.

The International Maritime Organization (IMO) has addressed itself to the problem of reducing marine accidents and pollution and the Nautical Institute supports its aims, particularly in the area of sub-standard ships and crews.

This paper discusses the danger areas and the methods that are and could be employed as preventative measures.

It also looks at the cost/benefit aspect, highlighting the eventual enormous costs of pollution accidents that could have been avoided by properly controlled investment in higher standards of equipment and personnel.

## POLLUTION IN THE SHIPPING INDUSTRY - PREVENTION IS BETTER THAN CURE

There are various methods of dealing with oil pollution. It can be left to disperse naturally, it can be dispersed by chemicals, it can be diverted from sensitive areas by booms or it can be recovered; but by far the best method of dealing with oil pollution is to prevent its occurrence.

All the aforementioned methods of dealing with pollution are costly. Even where natural dispersion is the course of action, a considerable amount of money can be spent on monitoring the oil slick's progress from aircraft.

Prevention is expensive, but where prevention is the result of conditions and actions carefully pre-planned and controlled, it is far more economical. Clean-up measures which are hurriedly carried out under emergency conditions deprive the on-scene commander of the most effective control. It therefore follows that the primary objective of an Environmental Management Programme must be to prevent pollution.

This paper will not deal in detail with every prevention action that can be taken, time and circumstances do not allow for that, but it will cover some of the main aspects in respect of the Marine Industry.

In a clean-up action not only is a great deal of money spent but the ecology is damaged and the oil is lost, even recovered oil having little value. The oil of the Amoco Cadiz at today's prices would be worth about \$57 million, plus the value of the ship at \$9 million, apart from the 2.1 billion dollars in claims.

I would suggest that the money involved would have provided the cost differential of all tankers having two engines, propellers and two independently operating rudders. If the Amoco Cadiz had been so fitted, she would not have been lost and the situation would not have occurred.

### Causes of oil entering the sea:

1. Natural seepage
2. Shipping accidents:
  - (a) Dirty ballast and tank cleaning;
  - (b) Spillage through explosion;
  - (c) Spillage whilst loading/discharging;
  - (d) Pumping bilges overboard;
  - (e) Spillage through collision/strandings/loss;
  - (f) Submarine pipeline leaks.
3. Shore terminal spillage
4. Inefficient shore-based separators
5. Disposal of dirty lube oil

6. Off-shore drilling blow-outs

Of the above six listed causes, No. 2 "Shipping accidents" and No. 6 "Off-shore drilling blow-outs" involving the Marine Industry are the ones I intend to deal with in this paper.

Shipping Accidents

(a) Dirty ballast and tank cleaning

The International Maritime Organization (IMO) has addressed itself to the problem of reducing marine accidents and pollution since 1957.

The 1973 Marine Pollution Convention (MARPOL), modified by additional protocols in 1978, provides for the fitting of segregated ballast tanks in new tankers over 30,000 DWT. It provides for crude oil washing in new crude carriers above 20,000 tons and the introduction of crude oil washing systems in existing tonnage on a phased basis down to 40,000 tons within the near future.

An authoritative estimate made by the National Academy of Science, based on 1973 figures, is that approximately 6.1 million tonnes of oil enters the sea annually. It was also estimated that some 18 per cent of this input was from normal tanker operations. That is about 1.1 million tonnes.

When the load-on-top (LOT) system was introduced into tank cleaning operations, the amount of oil going into the sea was reduced to about 10 per cent of the original figure. That means a saving of 900,000 tonnes of pollutant. The cost of implementing the load-on-top system was negligible but the saving of 900,000 tonnes of oil per annum at present-day prices makes the cost/benefit aspect very attractive. The introduction of crude oil washing will bring down the amount of operational pollution to a very low level.

If the MARPOL Convention with the 1973 protocols were to be adopted, then the operational discharge would be virtually eliminated. The introduction of crude oil washing, segregated ballast and attendant inert gas installation is very costly and the law of diminishing returns takes a hand. OCIMF produced the following table of Cost/Benefit Relationships based on the 1969 Amendments which are less demanding than the MARPOL Convention and protocols.

	Capital Cost \$ Millions	Reduced Discharge Thousand Tonnes	Cost/Benefit * \$/Tonne
Fully implement 1969 Amendments	Negligible	1,205	Negligible
Crude Oil Wash (all tankers over 150,000 dwt)	200	39	5,100
Retrofit Segregated Ballast (all tankers over 70,000 dwt)	4,300	47	91,500

\* It should be noted that this cost/benefit figure represents the capital expenditure necessary to prevent one tonne of oil per annum from entering the oceans.

(b) Spillage through explosion

MARPOL provides for inert gas systems on new tankers over 20,000 tonnes and the fitting of inert gas on a phased basis on existing tankers. This will reduce the dangers of explosion and goes hand-in-hand with crude oil washing as the tanks need to be made inert against the dangers of static.

Had the Betelquess been fitted with an inert gas system, the explosion and loss of the tanker, terminal and fifty lines at Bantry Bay might never have happened. The tanker would still have been badly damaged structurally as she was sub-standard due to metal wastage and was not even fitted with a stress calculator - an inexpensive item compared with the value of a ship.

There is no doubt that many explosions and losses would not have occurred if the ships concerned had been fitted with inert gas systems, although here a note of warning should be sounded.

The existence of an inert gas system on board is dangerous if it is not maintained and operated properly, particularly if the officers are unaware that it is not functioning properly and, are happily oblivious of the danger, carrying out the crude oil washing in a tank that has not been made inert.

Increasing accidents on tankers fitted with inert gas systems have caused concern, and the Nautical Institute has recently published an article in their journal Seaways by an installation consultant citing fourteen cases of improper and dangerous mishandling, lack of maintenance and even incorrect installation.

(c) Spillage whilst loading/discharging

This rarely occurs due to equipment failure but usually happens because of human failure; and where equipment failure does occur, human failure tends to compound it. Inadequate manpower, inattention to duty, and untrained personnel are the main causes of spills by overflows or improperly secured sea valves. About 50 per cent of spills in port are caused in this way. A prime example of this was the tanker Energy Concentration breaking in two because the cargo was off-loaded from amid ships whilst the end tanks were full.

(d) Pumping of bilges overboard

Thousands of ships and small craft daily pump their bilges overboard, mostly water but often with a small quantity of oil. This accounts for 2 per cent of the spills. In our own port operations, our tugs and launches pump their bilges ashore to slop tanks.

(e) Spillage through collisions/strandings/loss

Every year there are numerous collisions and strandings resulting in spillage and sometimes total loss. Although it is estimated that these accidents are responsible for only 3 per cent of the oil entering the sea, they cause a large amount of oil to be spilt, in a concentrated area, in a concentrated period of time. These incidents, like all the aforementioned shipping accidents, are all too frequently incidents in which "flag of convenience vessels" are involved.

The safe operation of tankers requires that they are owned and operated by responsible management who will man their ships with well-qualified and well-trained crews, and maintain the vessels and equipment to a high standard.

There is a shortage of well-qualified, well-trained seamen and many today are sailing the seas with certificates of dubious origin or with a dubious right to hold them.

There should be a uniform standard for manning, construction, equipment etc., and the standards should be uniformly applied irrespective of flag.

Governments and Classification Societies have the responsibility in this respect. Often classification societies are unwittingly aiding and abetting sub-standard shipowners by not penalizing them on their insurance premiums, as opposed to the responsible owner who spends money on maintaining his ship, only to find that he is lacking cargoes because the sub-standard shipowner is able to under-cut him on freight costs.

The attitude of insurers towards seaworthiness is puzzling. One would expect them to take a very close interest in the condition of the vessel that has become their liability, but they appear not to. Their plea is that they cannot afford to because of competition, but surely the ultimate victors in this competition will be those insurers who devote some money to insurance research. Any other form of business has to devote some of its money to research or it loses out to those who do.

Governments could bring about big changes in the situation by ratifying the conventions that IMO has brought into being; but they should do more, because legislation on its own is not sufficient; it must be enforced before the interests of safety can be served.

Governments have a right to inspect vessels entering their ports and refuse entry if not acceptable. Saudi Arabia does not accept vessels over fifteen years old but this appears to be somewhat arbitrary as a neglected ship can go to ruin in 10 years whereas a well-maintained vessel can be efficiently run for over 20 years.

A more realistic approach would be efficient inspections by Governments of countries owning ships and the Governments of those countries where the ship wants to trade. These inspections would become more searching as the ship ages.

(f) Submarine pipeline leaks

The seabed is becoming increasingly criss-crossed by submarine pipelines and all too often the exact location of the pipelines, as they snake their way across the seabed, is not known. During drilling operations etc., divers can go down to ensure that anchors are not dropped on pipelines, but ships do not have that facility and marking large areas on charts with the notation "Anchoring Prohibited in This Area" is not a foolproof precaution. A vessel could find itself in the position of being broken down and drifting in bad weather towards a drilling rig, thus being faced with the risk of dropping an anchor in an area where pipelines are vaguely known to exist or colliding with the rig. More accurate marking of pipeline locations would assist safe anchoring.

### Offshore drilling blow-outs

Whilst, strictly speaking, these do not enter into the sphere of the shipping industry, they are marine activities and are mentioned here to keep the problems of pollution by ships in perspective. They are less frequent than spillages from other sources but they are rather spectacular. A bad one was recently experienced in Nigeria but the supreme spill was the Ixtoc 1 in the Gulf of Mexico: 140 million gallons (about 3 1/2 million barrels) which makes the 1 1/2 million barrels of the Amoco Cadiz seem small. The flow of oil was of course over a period of 295 days. It initially started out at 30,000 barrels per day over the first two months, decreasing to 10,000 barrels per day over the next three months down to 2,000 barrels per day in the first quarter of 1980 and then down to 400 barrels per day. Often you might see newspaper headlines "The Gulf could not cope with Major Spills say experts." The experts were right. If the spill is big enough no one can cope, if coping means preventing the oil from reaching the shore.

Recently a well-blow-out in Saudi Arabian waters cost a score of lives and then gave the Region its biggest pollution problem to date, the clean-up of which will need millions of dollars. Money can be replaced, lives cannot, and the damage to the ecology affects people's livelihoods.

Many mariners advocate that wells being drilled and wellhead zones should be protected by a dedicated pollution and disaster response craft, and not merely a tug standing by with a few drums of dispersant. This is acceptable as an immediate first response, but what is really needed is a suitably large vessel capable of arriving quickly on the scene, from which fire-fighting, well-capping and pollution-control operations can be carried out. Such a craft would be expensive, but if the cost was jointly borne by oil companies operating offshore, the burden could be shared according to production wealth, which is in relation to the element of risk.

As this Region is bounded by eight countries, these vessels should fly the flag of the United Nations and be given freedom of movement through the various territorial waters, with special Customs and Immigration treatment.

The Mexican Company Pemex spent about \$133.5 million on the spill response. About 25 per cent of this amount was spent on environmental protection measures, including dispersant spraying, oil recovery, and beach clean-up. Only 4.5 per cent of the oil was recovered, 50 per cent burned at the well site.

The loss of \$100 million dollars in oil plus the \$133.5 million spent on the spill response, plus the cost of the damage to the environment, would seem to justify more expenditure on research and fail-safe equipment to avoid similar accidents.

To conclude this paper, the hope is expressed that no one will disagree with the premise that oil spill clean-up is never as effective as preventing the spill from happening. Unfortunately, prevention is not nearly so spectacular as clean-up and if prevention management is totally efficient, it will, as time passes and memories fade, generate resistance to preventative expenditure as the results become difficult to measure.

Governments should also be called upon to ensure progress by assisting IMO with its work and ratifying its conventions and then, above all, implementing them.



SESSION IV: COMBATING OF OIL SPILLAGE

- |  |  |
|--|--|
| 19. Methods Available for Combating Oil Spillages                            | I.C. White and<br>J.A. Nichols         |
| 20. Marine Oil Spill Response Capability in the<br>Kuwait Action Plan Region | P.B. Ryan                              |
| 21. Aramco Oil Spill Prevention and Response<br>Programme                    | J.E. Cuddeback and<br>Khalid Al-Qatari |

METHODS AVAILABLE FOR COMBATING OIL SPILLAGES

by

I.C. White and J.A. Nichols

International Tanker Owners Pollution Federation Ltd.,  
London, England, U.K.

ABSTRACT

Although most countries place great importance on the ideal of combating oil whilst it is still on the sea, the serious limitations of most offshore response techniques often result in extensive contamination of shorelines. Despite increasing acceptance of the virtual inevitability of this in the event of a major oil spill, the problems of cleaning up shorelines and disposing of the recovered oil and oily debris remain generally neglected.

The paper reviews a number of offshore and onshore clean-up techniques with particular emphasis on those which have proved effective in practice. The importance of an organization and management structure, combined with adequate pre-spill planning and training, will also be discussed.

## INTRODUCTION

When oil is spilt at sea it undergoes a number of physical and chemical changes, some of which lead to its dissipation whilst others cause it to persist on the sea surface. As a general rule, provided an oil remains at sea long enough, the dissipating processes are able to overcome the others. However, it is an unfortunate fact of life that many oil spills occur close to coastal areas which may be of ecological importance or amenity value and if these are to be protected, some form of response is required to combat the oil before it can cause damage. Although great emphasis is often placed on combating the oil at sea, the limitations of most offshore response techniques frequently result in extensive contamination of shorelines. The purpose of this paper is to review a number of offshore and onshore clean-up techniques with particular emphasis on those which have found widespread use.

## CONTAINMENT

Because of the natural tendency of oil to spread on water, it is often desirable to try to confine a spill to the area of the discharge. The purpose of containment is not only to localize the spill and thus minimize the area affected but also to facilitate removal of the oil by concentrating it on the water surface. Containment is, however, usually inadvisable in the case of spills of fresh crude oils and refined products in situations that would present a fire hazard.

Many different types of oil containment barriers have been developed. These include floating booms, sorbent barriers, air or water streams, air or bubble barriers and chemical barriers. The most commonly used are the commercially available floating booms. These vary in design depending on the particular manufacturer but normally have the following four basic components: a flotation chamber filled with air or some buoyant material; a freeboard to prevent waves from washing oil over the top; a skirt to prevent oil from being dragged underneath and a longitudinal support member to allow the boom to withstand the forces of winds, waves and currents. In addition, many booms also have weights or water-filled chambers to keep them perpendicular to the water surface and some system for joining sections together and for attaching or anchoring them.

Booms tend to be used in different ways in different situations. Offshore the approach frequently adopted requires the utilization of a large boom in a U- or V-shaped configuration downwind and close to the source of the spill in an attempt to prevent spreading and to concentrate the oil prior to recovery.

The second approach to the use of booms offshore is to deploy shorter lengths from a vessel or a pair of vessels in a sweeping mode. Because of its greater mobility this method can be particularly appropriate when the oil is formed into individual windrows, or where wind and water movements continually alter the direction of oil movement.

In more sheltered waters inshore, in estuaries and in harbours, booms can be used in a variety of ways. They can be deployed in an attempt to prevent or reduce the ingress of oil into sensitive areas; they can be used to contain oil in a harbour or along a shoreline prior to or during recovery operations, or they can be anchored in a diversionary mode. The latter is frequently the most successful method of operation, as careful consideration of the most appropriate angle and

position of deployment can reduce the current forces on the boom sufficiently to deflect the oil to a sheltered situation from where it can be recovered.

Unfortunately, all booms suffer from some basic limitations brought about by the forces of wind, waves, tides and currents. These frequently result in the failure of booms and loss of oil. One of the most commonly observed causes of boom failure arises from the fact that a boom held in moving water tends to act as a dam, with the result that the restrained surface water tends to be diverted downwards in an attempt to follow the water flowing underneath. At low current velocities a small quantity of oil droplets from underneath the bulk of oil trapped by the boom will tend to pass under the boom. As the current flow beneath the boom reaches a critical velocity, oil will be drawn from the surface and will escape under the boom. The current velocity initiating such an effect will, to some extent, vary depending upon skirt depth, the thickness of the oil film and the properties of the oil. However, as a general rule, the critical velocity at right angles to the boom can be taken to be of the order of 36 cm/sec (0.7 knots). When using booms in a U or V configuration offshore it becomes necessary to allow them to move at a speed relative to the oil so that the critical current velocity is not exceeded. Strong water movements also frequently limit the effectiveness of booms anchored downwind or around the vessel or installation.

The performance of booms can also be reduced severely by short-period waves that break on the structure causing a splash-over of water and oil. Depending upon the construction and deployment of the booms, submergence or rolling over may also occur. Wind too can put considerable pressures on booms especially if the direction is different from that of surface currents. This can also result in difficulties of deployment and alignment to the oil.

Whilst some of the problems caused by winds, waves and currents can be overcome by increasing the strength and dimensions of boom construction, too much development in this direction can hinder the storage and rapid deployment of booms, thus reducing their value.

Improvised booms constructed of straw, thick buoyant rope, fire hoses, logs or any other material formed into a floating barrier can be of value in protecting or diverting oil away from sensitive areas. However, the basic limitation of such systems is that they normally lack sufficient freeboard or skirt to prevent the oil from going over or underneath. As an emergency measure or as a supplement to commercially available booms they can, however, be useful. In certain circumstances (e.g. at the mouth of a small estuary or lagoon with little water movement) a physical dam of sand or some other readily available material may be the most appropriate solution, although considerable thought has to be given to the environmental consequences of altering the water flow patterns of the area.

Booms and barriers constructed with material able to absorb oil can be valuable in some circumstances especially when the oil layer is thin, or during rock washing operations.

Natural materials such as peat or straw can be used, or synthetic materials of a highly oleophilic nature (preferentially wetted by oil). Generally the use of such booms is limited, however, as the method of construction normally means that they cannot withstand more than very limited pressures. In addition, when contaminated, their handling and disposal can create problems.

Bubble barriers produced when air is pumped through a perforated pipe located below the water surface can produce a surface current that prevents oil from crossing. Such systems have to be installed as permanent features and are most

suited for surrounding tanker berths where their presence does not impede the movement of vessels. However, they are costly to install and maintain and require considerable amounts of power to operate. Siltation of the bottom or strong winds can also reduce their effectiveness.

Certain chemicals that act as surface tension modifiers will inhibit the spread of oil. When sprayed in low concentrations on to the surface of the sea around a slick they will tend to concentrate the oil and thus facilitate recovery. They can also be used to protect surfaces and shorelines by preventing the oil from adhering. They work most effectively with fresh oils but are not capable of holding oil against currents.

Finally, in some circumstances, high pressure air or water streams can be deployed to deflect oil from sensitive areas, to flush it from inaccessible areas or from certain types of shorelines and structures, or to move it towards recovery devices. They can, however, encourage the formation of both water-in-oil and oil-in-water emulsions which may have adverse consequences. They also require constant attention when employed in a containment or deflection mode.

## RECOVERY OF OIL

Recovery of spilt oil from the sea surface or from shorelines is clearly the ideal solution. Three basic approaches are available: the use of mechanical devices; the use of sorbents or manual recovery supplemented by non-specialized equipment.

### Mechanical recovery

Numerous specialized mechanical recovery devices (frequently termed "skimmers") are available for removing floating oil, ranging from purpose-built vessels of many hundreds of tons to small pieces of equipment that can be used from makeshift vessels. Although designs vary, the principles upon which the pick-up capability is based are relatively few, with differences in the physical properties of oil and water being utilized in an attempt to achieve a high recovery rate of oil with a minimum amount of water.

Weir-type devices are in many respects the simplest design as they aim to exploit the fact that oil floats on the water surface. Separation of the two phases over a weir or dam is followed by continuous removal of the oil from a holding tank. In order to achieve the maximum oil and minimum water recovery rate, many designs include self-levelling and adjustable skimming-depth features in an attempt to maintain the top edge of the floating weir at the oil-water interface. The most serious problem with these types of skimmer is their susceptibility to wave action which causes the device to suck air or water alternately. This can be particularly acute in devices incorporating a long weir. Their effective use tends therefore to be limited to very calm conditions such as are found in harbours or rivers, unless sufficient tank storage can be made available to accept the volume of oil and water collected and to permit its separation. They are also adversely affected by debris and tend to perform very badly with viscous or heavily weathered oils.

Suction skimmers are in some respects similar to weir-type devices and tend to be susceptible to the same problems, since their efficient use also requires them to float at the oil-water interface. The head of such skimmers is usually only an enlargement of the end of a suction hose to increase the surface area over which the

suction of an external pump operates. They are simple to operate and can effectively recover a wide range of oil types. Because of the adverse effect of waves, they are most effective in calm conditions where the oil can be boomed and concentrated. In harbours, bays and other areas where oil concentrates naturally, vacuum trucks which are normally employed for other purposes such as sewage collection or pumping farm manure may be the most appropriate form of suction system. These vehicles have the advantage of often being readily available, but suffer from the fact that, unless the oil is very thick, the recovery of large amounts of water is unavoidable as the hoses used normally have no specialized head. This problem can to a large extent be overcome, however, by allowing the recovered mixture to settle in the receiving tank so that the water can be drawn off the bottom whilst still on location.

One common type of skimmer relies upon the adhesion of the oil to the surface of a moving drum, disc, belt or rope which is continuously moved through the oil. Oil collected on the surface is removed by a system of scrapers or rollers and is deposited into some storage facility. The material of which the adhering surface is made varies considerably depending upon design, but is normally oleophilic. Materials used include metals, plastics and treated fabrics. Devices in existence vary from small skimmers capable of deployment by hand to purpose-built vessels. Many of the designs, however, have the problem that the rotational action upon which their operation depends tends to force the oil away from the collecting surfaces. This can be overcome to some extent by decreasing the speed of rotation or by ensuring that they are always maintained in a thick pool of oil. Systems that are self-propelled through the water, whilst suffering the same problem, are able to manoeuvre to the heaviest concentration of oil. The efficiency of the different designs varies considerably with different types of oils. Many work best with medium viscosity oils and fail to efficiently recover very viscous oils or water-in-oil emulsions where the presence of high concentrations of water limits the adhesion to the surface. The fabric or rope type devices tend to work effectively with a wider range of oils. Debris can also be a problem with many such systems, especially those using rotating drums or discs. A recently developed system that can be considered to be a variation within this category of oil recovery device utilizes an array of oleophilic rope mops that are towed behind a vessel. A paravane is attached to the assembly to spread the rope mops over a wide area and keep them clear of the wake and track of the vessel. When the rope mops are near-saturated with oil they are recovered on board the vessel and the oil squeezed out prior to redeployment.

A number of devices have been developed that incorporate an inclined rotating belt that forces the oil beneath the water surface as the vessel moves forward. Because of the method of operation, these devices tend to be large and self-propelled. The oil forced downward by the belt passes to a collection well under the vessel from where it is pumped to storage. The concentration of such devices tends to be greatest with low specific gravity oils that are more buoyant, and reduced considerably by thick weathered or highly emulsified oils. Many have screens to counteract the effects of debris.

A number of skimmers based upon the centrifugal separation of oil and water are in existence. These devices draw the oil into a collection area where it is concentrated in a vortex and subsequently pumped to an oil/water separator or storage tank. These skimmers are limited by waves and currents that tend to prevent the ingress of oil in a similar way to weir-type skimmers. A high recovery of water or formation of oil-in-water emulsions can also result.

In addition to the basic designs described, a number of other approaches have been developed that utilize grids and conveyor belts. All devices, however, suffer

to a greater or lesser extent from a number of fundamental limitations when they are deployed at sea. First they will not operate effectively in anything but relatively calm conditions. For most skimmers, waves in excess of about one metre will result in the recovery of a far greater quantity of water than oil. Similarly, the safe operation of many devices is impossible in anything approaching moderate to rough seas. For both reasons their effective use is usually restricted to sheltered water areas as found near the coast or in harbours and estuaries. Most devices are also limited in the range of oils they will effectively recover. Since many depend upon the operation of external pumps, the limitations of such systems to handle viscous and highly weathered oils can be a severe handicap. Screw pumps can overcome these limitations. The effects of debris on the operation of many skimmers and the logistics of handling and storing recovered oil impose further restrictions on their use.

However, the basic limitation of oil recovery equipment used out at sea results from the natural tendency of most oils to spread rapidly on the sea surface and for slicks to become fragmented. The result is that the oil encounter rate of the skimmer at the necessarily slow operating speeds will almost invariably be so low that recovery of significant quantities of oil will be virtually impossible. Whilst booms may be used in a U or V configuration in an attempt to overcome this limitation, their deployment, operation and control are frequently very difficult and often require a minimum of three vessels, trained personnel and considerable logistic support, including aircraft for direction and control. To have any chance of being effective they must also be deployed within hours of the oil release occurring and before spreading and weathering are advanced. Such a response is therefore rarely effective for dealing with a large instantaneous release, although, depending upon water movements and weather conditions, it may be a far more practical proposition in the event of a continuously leaking tanker or oil rig where there should be adequate time to mobilize the required equipment and logistic support.

The approach of using recovery devices or some form of pump in association with short lengths of boom, nets, floating 'bags' or oleophilic ropes deployed from a single vessel and used in a sweeping mode along individual windrows in many respects presents a more realistic and flexible approach to collection of oil at sea. However, encounter rates are again almost invariably low and a large number of such single ship sweeping systems would have to be on the scene rapidly in a major oil spill and controlled from aircraft or helicopters overhead if a significant benefit was likely to be achieved. A speedy response would also be essential before weathering processes rendered the oil unpumpable.

Most of the categories of recovery device described above are designed to collect floating oil that is in a relatively liquid form. There is far less specialized equipment available that is designed to cope with oil once it is stranded on shorelines and has perhaps become mixed with seaweed and other debris. Suction devices or sludge pumps may be useful if the oil is thick or can be concentrated in pits or trenches. Devices that incorporate conveyor belts, oleophilic rope mops or other material to which oil adheres can also on occasion prove valuable if the stranded oil can be dislodged from the underlying substrate and moved towards the recovery device through the use of steam, hot water and high pressure water hoses. General debris collecting equipment employing rotary or vibrating screens can also effectively collect tar balls or highly weathered oil from sandy beaches. However, little specialized equipment is currently available for collecting fresh oil or relatively fluid emulsions deposited on shorelines.

A recently developed piece of equipment based upon sand washing machinery used in the water industry aims to liberate the oil from contaminated beach material

through vigorous mixing with hot water in situ. The oil is separated off and taken away for processing, leaving the cleaned beach material to be redeposited directly back from where it was obtained, thus avoiding the need to remove and dispose of large quantities of contaminated material. Study is also under way in various parts of the world on mobile equipment that will selectively pick up stranded oil through adherence to specially designed surfaces. Once again, however, the type of shoreline, nature of the beach deposits and stranded oil will be crucial factors in determining effectiveness.

#### Sorbents

The second major approach to the recovery of spilt oil is by use of sorbents. These work either by adsorption (adherence to surfaces) or by absorption (uptake into the structure of the material). There are three basic categories of sorbents: natural organic materials such as straw, peat and sawdust; mineral-based materials such as volcanic ash and vermiculite; and synthetic organic substances such as rubber, polystyrene and polyurethane. These latter materials tend to be most favoured because of the greater capacity for oil in relation to their volume and the fact that they are often reusable.

In general, sorbents do not play a major role in the initial stages of the clean-up of a major spill on the sea. In the main, this is because of the difficulties of applying and recovering sufficient of the material to collect a significant quantity of oil. Sorbents are therefore most commonly used during the final stages of a clean-up operation to remove small amounts of oil remaining on water surfaces, shorelines or other areas where other techniques are inappropriate or impractical. They are sometimes also used in order to afford some protection to shoreline areas where oil is likely to strand.

The recovery capacity and limitation of the different products vary considerably. Many of the natural substances tend to absorb water as well as oil unless treated with an oleophilic compound, with the consequence that they tend to sink when saturated, making clean-up impossible. Other materials absorb oil rapidly but do not retain it when picked up.

Finely powdered sorbents are often difficult to distribute and to recover, especially on the open sea where containment and control are difficult. Sheets, booms or pads of synthetic organic material, whilst reusable and easier to control, can, like all sorbents, create problems far afield if not recovered. Disposal of the oil-soaked material can also present considerable problems especially if burning is not feasible or not allowed because of environmental concern.

#### Manual recovery

Most major spills are ultimately cleaned up by the manual recovery of oil using a variety of unspecialized equipment. For example, the removal of oil from relatively inaccessible rocky areas, if considered necessary, can usually only be accomplished by personnel using shovels, scoops and buckets. Similarly the removal of bulk oil from marsh areas, where physical disturbance is frequently more damaging than the oil, may again require the use of strictly controlled teams of workers using shovels to remove the oil and bags to transport it away. This is especially the case if the oiling is slight and scattered over a wide area. The removal of bulk oil from hand-packed sand beaches may require the use of mechanical graders, front-end loaders and bulldozers, although control of the operations is essential if excessive removal of beach material is to be avoided.



Mechanical removal of oil from stone and cobble beaches presents many more problems and invariably involves the removal of large volumes of beach material. In such instances other approaches, including leaving the oil to weather and degrade naturally, will have to be considered if the adverse consequences of clean-up are not going to outweigh the benefits of removing the oil.

#### CHEMICAL DISPERSANTS

The use of chemical dispersants to combat oil spillages at sea remains the subject of considerable controversy. In part this is a result of a lack of understanding of their mode of action, their incorrect usage during past oil spills and the misinterpretation of the results of necessarily artificial toxicological laboratory experiments by those who have little knowledge of the problems posed by a major oil spill.

Dispersants neither destroy nor sink oil but simply enhance the natural process of dispersion by breaking up the oil into small discrete droplets that can become distributed in a large volume of the sea through the action of waves, currents, and other water movements and do not recombine to form a surface slick. The increase in surface area brought about by droplet formation also enhances the natural degradation process that results eventually in the removal of the oil from the environment.

Dispersants can in general be classified into two categories: those which are hydrocarbon solvent-based and intended for neat application to oil and those which are alcohol or glycol solvent-based and which can be applied neat or pre-diluted with sea-water. Those of the latter type are commonly referred to as concentrates.

The successful use of dispersants at sea depends upon the efficient distribution of the chemical on to the floating oil, followed by adequate mixing to form an oil-in-water dispersion in the upper layers of the sea. The most commonly used equipment to date is that designed by the Warren Spring Laboratory (WSL) in the United Kingdom, which delivers chemical at a fixed rate through midships-mounted spray booms and utilizes surface breaker boards towed behind the spraying vessel to provide the mixing energy.

The new generation of dispersant concentrates now available, if used undiluted, do not require the same degree of mixing as the older type of products, and often the natural movement of the sea is sufficient. This has opened up the possibility of applying dispersant over the bows of vessels without the use of surface breaker boards. Such an approach not only simplifies the equipment but gives the spraying vessels greater manoeuvrability. In addition, they are able to operate at higher speeds since the adverse effect of the bow wave in diverting the oil from the midships-mounted spray system is obviated.

Despite such improvements, vessel spraying techniques will always have serious limitations, not least of which are the rate of treatment of oil and the inherent difficulty of detecting those slicks most requiring treatment from the bridges of ships.

The efficacy of undiluted concentrates, however, also makes aerial application techniques feasible, which overcome most of the problems associated with shipborne systems. There can be little doubt that the technique of aerial application offers the most effective response for combating many offshore oil spills. The advantages

of an airborne operation are speed of response, rapid treatment rate and high degree of control, resulting in optimal use of dispersant. Although the technique has yet to be fully exploited, it has been employed successfully using small agricultural spraying aircraft. However, these aircraft are usually single-engined machines with limited payloads, and although well suited to combating relatively minor spills close inshore, they have severe limitations when considering the response to larger offshore spills. There is no reason why the technique should not be extended to larger multi-engined aircraft. Helicopters also have a role to play, the main advantage being their ability to operate from any location where fuel and dispersant can be sited, and their greater manoeuvrability.

This all suggests that there is no single aircraft, fixed wing or rotary wing, suitable for all oil spill situations and several types may be necessary to provide a complete response package. Nevertheless, it seems certain that aircraft will be used more and more in the future and may eventually replace surface vessels for all but minor spills in ports and harbours.

Irrespective of method of application, dispersants have their limitations when used on oil at sea. Thus, whilst as a general rule they are capable of dispersing most liquid oils and liquid water-in-oil emulsions, they are not suitable for dealing with stable, viscous water-in-oil emulsions (mousse) or oils whose pour points are near to or above that of the ambient temperature.

In practice this can mean that dispersants have little or no role to play in spills of heavy fuel oils or in incidents where crude oils have had time to weather. In such cases a response based on dispersant application may be of no significant benefit 24 hours or so after the initial spillage.

Dispersants can, however, have a role to play in shore clean-up, particularly on lightly oiled beaches or as a final stage in cleaning, after the bulk oil has been removed by manual or mechanical techniques. Hydrocarbon solvent-based dispersants are usually most appropriate in these circumstances since they provide better penetrating power for the more weathered oils usually encountered on shore. Where possible, spraying should be carried out on an incoming tide not more than 20 minutes before immersion to avoid penetration of the oil into the beach and to minimize the possibility of adverse effects on inter-tidal organisms. Usually, surf action is sufficient to give adequate dispersion but, in very calm conditions, additional agitation from fire hoses may be required.

A variety of equipment is available for applying dispersants to beaches, from small back pack spray units to amphibious vehicles fitted with spray booms. They can also be applied in conjunction with hot-water washing and high-pressure water streams. If beaches are inaccessible by road, dispersant can be applied from the sea using shallow-draft vessels, such as landing-craft, and floating hoses. When residual oils are deposited on rocks and on man-made structures, dispersant is not usually very effective since it runs off the contaminated surface before having sufficient time to penetrate the oil. This problem can be overcome by gelling hydrocarbon solvent-based dispersant so as to increase contact time between the dispersant and the oil. The gel is prepared in situ and sprayed directly on to the oil surface where it is left in contact with the oil for several hours, after which time it is removed, either by tidal action or hosing down.

The most controversial aspect of dispersant usage relates to the toxicity of the products to marine life and to the basic fact that use of the technique requires the addition to the sea of another pollutant. Over the last decade or so, a considerable amount of development work and experimentation on the effectiveness, fate and effects of dispersants and of oil/dispersant mixtures has been carried out

with the result that most modern products have a considerably reduced toxicity to marine organisms, as determined by standard laboratory bioassay procedures. However, the debate on the advantages and disadvantages of using dispersants continues in international fora, the scientific community and the media.

It must be appreciated that virtually all substances are toxic to life under certain conditions. The effect of a substance on a marine organism or on a biological community depends basically, not only upon its inherent toxicity, but on the concentration and length of time of exposure. In the case of dispersants used at sea or on shore, the rate of dispersion and dilution is therefore of paramount importance. The hydrographic conditions, method of application, as well as the particular biological characteristics of the area, will also be crucial factors determining whether significant damage will be caused by the dispersant or by the resulting oil/dispersant mixture.

However, the decision on dispersant usage will rarely depend solely on whether or not there are likely to be adverse environmental effects. Ultimately, it will be a balanced decision related to priorities for protection, the probable effectiveness or the other responses available (e.g. mechanical recovery) and the probability of damage to other parts of the marine environment, amenities or industries likely to be caused by the oil if nothing is done. The chances are that such decisions will also be based on compromise, as all interests cannot be served to the same degree. For example, protection of amenity beaches or bird colonies close to the shore might call for the extensive use of dispersants even at the risk of damaging marine life or fish stocks further offshore. Conversely, if protection of the fisheries is considered of primary importance, then damage to birds, shorelines, coastal amenities and industries through contamination with oil would have to be accepted even if the risk to fish and shellfish stocks was considered minimal. Clearly, therefore, the decision will be a matter of basic policy agreed in advance.

Despite international differences on the subject, it is becoming increasingly recognized that dispersants, if applied correctly in a controlled manner and after consideration of the particular circumstances of the incident, have a role to play in combating marine oil spills. They should, therefore, be part of the armoury available to oil spill clean-up controllers, but never regarded as a panacea for all ills.

#### SINKING

Since many of the problems caused by oil result from it floating on the surface of the sea, an attractive solution is to increase its density sufficiently so that it sinks to the sea bed. This basic concept resulted in the development of techniques for applying a wide range of dense materials to oil on the surface of the sea. To be effective the material has to be oleophilic so that it will attach itself firmly to the oil; and relatively fine-grained so that it is both easy to apply and provides a large surface area for adsorption of oil. Common sinking agents include chemically treated sand, chalk, fly ash and cement.

Whilst the technique has been shown to be effective in some situations, there are also a number of problems associated with its use. Thus the sunken oil may resurface in time or may move under the action of bottom currents and contaminate sensitive areas. Since the biodegradation of sunken oil is slow, the oil can persist for long periods, damaging or contaminating bottom-living organisms as well as fishing gear, especially trawls, lines and pots that are used on or near the sea

floor. For these reasons the deliberate sinking of oil is generally no longer favoured.

#### GELLING

Gelling agents are chemicals which increase the viscosity of oil and thereby reduce its rate of spread over the water surface. By forming a gel, oil on the surface of the sea might be converted into a form that could be recovered by simple mechanical techniques (e.g. nets, grids). In addition, if oil in a ruptured tank could be converted into this form, no outflow would occur due to the increased viscosity.

Whilst an attractive prospect, the technique has never been utilized during a major spill at sea. This is basically because of the considerable difficulties in intimately mixing the agent with the spilt oil. The large quantities of gelling agent required and the time taken for the gelling process to occur also limit its application.

#### BURNING

Burning of oil on the sea often appears to the layman as the most obvious method of treatment because of the known flammability of many hydrocarbon products. Unfortunately, as oil weathers and the more volatile components are lost through evaporation, an oil slick becomes progressively more difficult to ignite. Spreading also increases the difficulties and it becomes virtually impossible to ignite and sustain combustion of a thin layer (less than 3 mm thick) of crude oil on water because of the considerable cooling effect of the water underneath. If combustion is achieved it is usually incomplete and can give rise to troublesome tarry residue and severe air pollution. Numerous agents have been developed to promote ignition and combustion but have never proved successful at spills on the few occasions they have been tried on oil on the open sea.

The ignition of oil in confined situations and around a stranded tanker is clearly undesirable for safety reasons and to be avoided in virtually all situations.

Burning is sometimes employed during shore clean-up, but is difficult, especially if the oil is highly weathered or has a high water content. The use of high temperature flame-throwers may assist, but incomplete combustion can result in a more viscous residue to deal with. Heating may also cause the oil to become less viscous and to penetrate into the substrate. The air pollution resulting from such operations can also cause problems.

#### BIOLOGICAL AGENTS

Biodegradation of oil by bacteria, fungi and yeast ultimately removes spilt oil from the marine environment. Unfortunately, the process is slow, especially for certain hydrocarbon components, and is limited by temperature, nutrients and the dissolved oxygen in the surrounding waters.

A number of commercial preparations have been developed to enhance natural biodegradation. Freeze-dried micro-organisms capable of utilizing certain hydrocarbon components are available for application to oil slicks on the sea. Oleophilic nutrients have also been developed. However, considerable problems remain as regards distribution, mixing and keeping the bacteria and nutrients associated with the oil. Even if achieved, the rate of biodegradation of floating slicks of oil or water-in-oil emulsion would be extremely slow and unlikely to achieve a significant reduction in volume in the time scale required to minimize damage to threatened shorelines.

The technique is also of little benefit for dealing with stranded oil out of contact with water since the micro-organisms can only function at the oil-water interface. It may be of some slight benefit for dealing with oil stranded in environmentally sensitive areas in which a nutrient-rich environment can be provided. However, oxygen availability and temperature are likely to remain limiting.

#### DISPOSAL OF RECOVERED OIL

A discussion of clean-up methods would be incomplete without consideration of what can be done with any oil collected. Unless oil is dispersed at sea, either naturally or through the use of chemicals, the volume of material to be dealt with in a major spill is often considerable and sometimes in excess of the amount originally lost, due to the formation of water-in-oil emulsions and incorporation of sand, seaweed and other debris. Disposal of oil and oily debris recovered during clean-up operations at sea and on shore remains a very significant problem and a potential limitation to the use of some techniques.

The procedures available for dealing with recovered oil and oily debris are many but all have limitations. Relatively uncontaminated oil may on occasions be accepted by local oil refineries, especially if they possess slop reception facilities and the like. However, there is frequently considerable reluctance to take large quantities in view of the fact that water and salt contamination may interfere with the normal operations of the plant. The oil having lost its light ends through evaporation is also of reduced value and may only be worth processing after blending with naphtha or other petroleum products rich in low boiling components. Commercial re-processors of waste oil will frequently regard the treatment of oil recovered from clean-up operations as uneconomic for similar reasons. Reclamation is therefore rarely a viable method for disposing of large amounts of oil and is certainly not the economic proposition it is sometimes made out to be, especially if transport and storage are costly.

The high viscosity, particularly of weathered oil and emulsions, can introduce severe problems in pumping and handling collected oil, thus inhibiting effective disposal. Some relief can be given by the use of chemical emulsion breakers, which have the effect of reducing the viscosity of many oil-water mixtures. These additives do not always achieve complete phase separation of emulsions, but the reduction in viscosity is often sufficient to improve pumping operations after recovery. In instances where the oil is too viscous to pump and manual recovery is the only practical solution for collection, emulsion breakers can be used in a batch process to render the material pumpable prior to final disposal.

Probably the most frequent procedure for disposal, particularly of heavily contaminated oil, is burial. However, selection of the site is critical if

contamination of ground water supplies and other detrimental effects are to be avoided. Consideration of the soil conditions, geological structure and surface topography is also vital in order to determine the potential for the oil to migrate in all directions. Because of these and other related problems, land disposal is an unavailable option in some countries or specific locations.

Burning of recovered oil is a commonly used technique, especially where in situ disposal is advantageous because of transport difficulties. However, heavily weathered or emulsified oils will rarely burn easily and may need the addition of some wicking agent. Once burning, all oils can also produce thick black smoke which may carry with it droplets of unburnt residues causing an unacceptable degree of air pollution and possible contamination of nearby areas by "black rain." The location at which burning is carried out therefore has to be chosen with care, especially if penetration of the substrate by the heated oil is also to be avoided. Low-temperature burning will also tend to leave a tarry residue which may cause subsequent disposal problems.

Incineration of recovered oil overcomes many of these problems. However, suitable incinerators are rarely available to deal with large quantities and corrosion problems can be caused to the structure by water and salt-laden material. Small portable incinerators of simple construction, but with limited capacity, have been developed for use in situ. These can be valuable, particularly in remote locations where other disposal options may be absent.

Procedures that make use of natural or artificially enhanced biodegradation processes have been found to be successful in some instances. One approach is to spread the material on land, followed by fertilizers and repeated ploughing to ensure adequate aeration and high rate of biodegradation. Commercial preparations of bacteria may be added but often naturally occurring populations suffice. As with burial, land farming should only be carried out after a careful consideration of soil type, drainage patterns, climatic conditions and nature of contaminated material. Whilst it has been proved that such procedures can result in rapid removal of oil and the growth of crops only months after treatment, it remains applicable only to lightly oiled material and so contributes little in instances of extensive and severe contamination. Similar comments apply to composting techniques where contaminated oil is mixed in layers with other organic materials and fertilizers.

Use of lightly contaminated sand and shingle in road construction, land reclamation and similar works has also on occasions proved successful, given prior detailed investigation of the particular sites involved. The use of quicklime (calcium oxide), which reacts with the water to produce calcium hydroxide and at the same time acts as an efficient cloaking agent, has been found to make such approaches more viable. The reaction with water is strongly exothermic and the heat produced renders the technique suitable for viscous residues and heavy fuel oils. Its successful use on a large scale during two recent major incidents has resulted in the development of procedures for the efficient mixing of the contaminated material with the correct proportions of quicklime and the reduction of secondary pollution problems.

As a consequence of the limitations of all the techniques available, recovered oil and oily debris frequently remain in temporary storage for many years following a major oil spill. Whilst the subject continues to be studied by many Governments and other organizations, novel approaches are rare and the potential problem of disposing of large quantities of material remains of paramount importance for a number of countries.

## SELECTION OF RESPONSE

Having demonstrated the wide range of techniques and equipment available for combating oil spills and the absence of any universal panacea, it should be apparent that in order to determine the most appropriate response in the event of an oil spill, it will always be necessary to carry out a rapid and detailed evaluation of the nature of the particular incident. This evaluation will require detailed consideration of a wide variety of factors and, in order to be carried out effectively within the time scale required, will be dependent upon the existence of much basic information in the form of a well-prepared contingency plan. Of primary importance will be consideration of the location of the incident, the probable rate and direction of movement of the spilt oil by the prevailing winds and currents, and its likely persistence on the sea surface. It will also be important to obtain the best estimate of the quantity of oil already spilt and to predict the extent and nature of possible future releases. Once this has been determined, the short- and long-term threat to the resources of the area can be established and the most appropriate response identified, by taking into account the priorities for protection, the probable effectiveness of the treatment methods available and the probable damage to the resources of the area likely to result from the oil alone or any treatment method.

Whilst this paper has discussed various techniques for combating oil spills, it should not be forgotten that occasionally the best course of action will be to simply monitor the movement of the oil whilst it is at sea, because a combination of rapid natural dissipation and distance from resources requiring protection will render treatment unnecessary. There will also be occasions when mounting an effective active response at sea will prove impossible due to a combination of the nature and quantity of the oil, weather and sea conditions, and the proximity of the source to shorelines. In such cases the most appropriate response may be to accept the inevitable and devote all effort to the preparation of the response forces for the protection and clean-up of inshore waters and shorelines. Even once the oil has come ashore, there will be occasions when the best and least damaging response will be to do nothing but to leave the majority of the oil to dissipate and degrade naturally.

Because of pressures from politicians, the public, the media and other interests, the option of deliberately refraining from actively responding will never prove easy. Therefore, on occasions during past major oil spill incidents, a response has been initiated mainly in order that something could be seen to have been done, even though all technical opinion was in agreement that it would do no significant good and could even do harm.

## CONCLUSIONS

Irrespective of the response selected, it is probable that an event as unpredictable as a major oil spill will always present considerable problems, given the extent of the impact on the population and resources of a country and the lack of a fully satisfactory technological solution. It is generally recognized that an ability to deal effectively with oil whilst it is out at sea would be ideal, as it would prevent ecological, amenity, fisheries, industrial and general economic damage associated with severe contamination of inshore waters and shorelines. The need for expensive and time-consuming shore clean-up operations would also be removed and public disquiet lessened. With this goal, a

great deal of effort has been devoted to the attempted development of an offshore response that can be mobilized rapidly when an incident occurs. In some countries the response is based on the use of collection devices, whereas others have relied mainly on shipborne dispersal techniques. Both, however, have been shown to have severe operational limitations in major spills at sea, due to the natural tendency of oil to spread on the sea surface, to move under the influence of wind and currents and to break up into windrows, patches or other uneven configurations due to the forces of wind, waves and currents. The result is that spilt oil has the potential to rapidly cover an enormous area, thus calling for both a very rapid response and one sufficient to cover a great area. Unfortunately, experience from past major spills suggests that collection devices or shipborne dispersal systems, along with the required logistic support and control platforms, can often not be mobilized within the time available before it reaches shore.

The use of aircraft to spray undiluted concentrate dispersants does overcome some of the limitations of both collection devices and shipborne dispersant spraying systems and potentially offers the most effective response for combating many offshore oil spills. However, there still remain the limitations imposed by availability of the correct aircraft for the particular situation; speed of mobilization; effects of weathering, emulsification and spreading; and lack of acceptance in some countries of the widespread use of dispersants.

This leads to the conclusion that, for the foreseeable future, extensive contamination of shorelines remains virtually inevitable in the event of a major oil spill in coastal waters, unless winds and currents prevail to take the oil offshore where it can dissipate naturally without intervention. Despite increasing acceptance of this unpalatable fact by many administrations, the technical and organizational problems of cleaning up shorelines and disposing of collected oil and oily debris have been generally neglected.

There is also a continuing lack of appreciation of the fact that the basis of effective clean-up response is a combination of good contingency planning organization and control. No amount of sophisticated equipment will compensate if one or all are lacking.



MARINE OIL SPILL RESPONSE CAPABILITY  
IN THE KUWAIT ACTION PLAN REGION

by  
P. B. Ryan

Gulf Area Oil Companies Mutual Aid Organization,  
Manama, Bahrain

ABSTRACT

The paper reviews and evaluates existing technical resources, trained manpower, communication and infrastructure capacities of both industrial and Governmental entities in the Region to respond to major oil spillages. Conclusions are drawn concerning the relative roles MEMAC might play in improving oil spill response in the Region.

## INTRODUCTION

The Kuwait Action Plan Region comprises the marine environment and coastal areas of Bahrain, Iran, Iraq, Kuwait, Oman, Qatar, Saudi Arabia and the United Arab Emirates (UAE), and encompasses the largest offshore oilfield, and the largest oil exporting terminal, in the world. As such, the Region must be considered as one of the highest risk areas of the world from the point of view of oil pollution. Potential pollution sources in the Region include offshore exploration and production facilities, oil-loading terminals and oil tankers. In addition to this high concentration of oil-handling facilities generally, the sheer volume of marine traffic is an added risk factor with some twenty tankers per day moving in and out of the sea area, together with a variety of other shipping which, in total, results in an overall average of one vessel movement through the Straits of Hormuz every 22 minutes.

Environmental concern over the problems caused by oil pollution has been growing steadily in the Region over the past ten years or so. For much of this time, the oil companies themselves have taken the initiative in developing a response to oil pollution beginning with an "in-company" capability to deal with purely local spillages occurring during routine operations and then expanding this to a Regional co-operative capability through the agency of the Gulf Area Oil Companies Mutual Aid Organization (GAOCMAO). The very rapid increase in industrial activity evident throughout the Region during the last four to five years has been paralleled by a corresponding increase in environmental concern, and this has involved a much greater degree of governmental involvement than was apparent before. Despite this increasing involvement in environmental affairs by Governments, the primary operational responsibility for oil pollution clean-up remains with the oil companies and this situation is only slowly changing.

This paper seeks to review the capabilities of the various concerned agencies in the Region to respond effectively to pollution incidents resulting from oil spillages and to assess the total aggregate capability on a Regional basis. The principal organizations involved in oil pollution control and clean-up are the national Governments of the countries bordering the Region and the oil companies operating in those countries. In addition to these are the various commercial organizations which supply pollution control equipment and materials, and the contractors who specialize in pollution control equipment and clean-up activities. Information was gathered from as wide a selection of these agencies as was possible. During the preparation of this study, the Region experienced two major oil spills which almost certainly caused more concern to more countries than have any other spillages in the Region for the past ten years or more. Most of the information upon which this paper was based relates to the situation prior to this recent oil pollution and hence may now be out of date. However, the situation revealed by the study, compared with what it now is subsequent to that pollution, should provide a useful starting point for determining what lessons were learned as a result of the spillages and to what extent Regional oil spill response capability will be improved in the future as a result of recent events. In preparing this study, requests for information were forwarded by letter and cable to the relevant ministries in the Governments of the Region and to the oil companies. These requests were later followed up by visits by the consultant to Bahrain, Kuwait, Qatar, Saudi Arabia and the United Arab Emirates. Visits were not made to Iran, Iraq and Oman. The results of the study, although incomplete, may be indicative of the level of preparedness which exists in the Region, at least in those countries visited.

## NATIONAL SPILL RESPONSE PLANNING AND CAPABILITY

Regional response capability is dependent upon the capability of individual countries in the Region to respond to oil spills. National capabilities in the Region vary within very wide limits and in most cases the functional responsibility for pollution clean-up, when it occurs, is essentially given to the oil company or oil companies operating in the country. A brief summary of the current situation in each of the countries of the Region follows:

### Bahrain

In the State of Bahrain, responsibility for oil pollution control and clean-up on the national scale lies essentially with the Ministry of Health. A permanent inter-ministerial environmental protection committee is currently being established with the primary aims of co-ordinating national oil spill response activities and preparing a National Oil Spill Contingency Plan. At the present time, all oil pollution expertise resides within the Bahrain Petroleum Company Limited (BAPCO) and for this reason the State's oil spill response function has been temporarily delegated to that Company under the general direction of the Government of Bahrain with the help of government personnel, equipment, and materials when necessary. Owing to the small size of the country, communication between various Ministries and BAPCO are good and a very high degree of co-operation and co-ordination can be achieved; this was well demonstrated during the recent oil pollution incidents in Bahrain and an excellent rapport is evident between BAPCO and the principal government agencies involved in pollution control.

No formal oil pollution watch is maintained to detect oil slicks in the Bahrain area and thereby give early warning of any pollution threat. Military and civilian aircraft and coastguard vessels maintain routine surveillance and are expected to report sightings of oil slicks to the duty Security Officer of BAPCO and this is relayed to the Environmental Conservation Group. Recent events, however, have shown that this informal system of surveillance and reporting is not wholly effective.

The only oil pollution control equipment and materials permanently available in Bahrain comprise those owned and utilized by BAPCO. The equipment consists of a variety of dispersant spray sets, containment and recovery systems, sorbents and various radio communications units. Active consideration is being given to increasing equipment holdings to include an offshore oil-recovery system, aerial spray systems, additional offshore booms, and a beach-cleaning tractor. No specialized equipment is currently available from government sources although essential back-up equipment such as earth-movers, dump trucks, vacuum tankers, etc., can be mobilized when necessary.

The conventional response to oil pollution at sea is normally one of spraying with low-toxicity, water-based dispersant chemicals, with some boom defence for essential facilities. Dispersant spraying is permitted in all coastal areas where there is sufficient water depth to allow adequate mixing, with the one exception of the prawn breeding grounds, south-west of the Sitra loading terminal; in this area spraying is prohibited. Small-scale oil recovery operations can be mounted in sheltered inshore waters, but there is no "in-house" capability at present to recover surface oil offshore.

Beach clean-up consists essentially of manual/mechanical removal of contaminated material followed by renovation with application of clean sand. Disposal of contaminated material is catered for in specially designated areas inland where controlled burning of combustible materials would be carried out along

with landspreading of contaminated sand. Consideration is also being given to the possibility of using microbial preparations for clean-up of lightly contaminated shoreline areas; beach protection/clean-up chemicals have also been used in similar situations.

Modest stocks of dispersant concentrate chemicals and beach cleaning chemicals are maintained by BAPCO and these can be supplemented when necessary from the dispersant stockpile maintained under the terms of the GAOCMAO agreement, to which BAPCO is a signatory.

At the present time BAPCO is able, when necessary, to call upon the services of two senior staff members who have specialized knowledge of, and training in, all aspects of oil pollution control and clean-up and some considerable field experience in the use of oil pollution control equipment and direction of field operations. A further five senior staff members are being given detailed training in oil pollution control methods. Only one of these staff members works full-time on environmental pollution control problems, the other members holding various other supervisory positions in the Company.

#### Iraq

No up-to-date information was available to the consultant concerning the level of spill response capability in this country. Seven years ago the International Maritime Organization engaged a consultant to study the implications for Iraq of the "International Convention for the Prevention of Pollution from Ships - 1973". Various recommendations were made by that consultant as to how a minimum oil spill response function should be set up in the country, but no information is currently available to determine to what extent these recommendations have been implemented. What national contingency plans are available to deal with marine oil pollution emergencies is unknown.

The Iraq National Oil Company (INOC) would appear to have a limited response capability according to data supplied by GAOCMAO. Two offshore dispersant spray units and one inshore unit are held by INOC for clean-up of oil spills, together with about 300 metres of offshore boom. As a member of GAOCMAO, the oil company has the right to call upon other member companies for assistance in cases where pollution incidents are too large for INOC alone to handle. It is presumed that INOC have their own oil spill response plan, since this is a mandatory condition of GAOCMAO membership, but no details have been obtainable.

#### Iran

The level of oil spill response within Iran, either from government sources or from the oil companies operating in the country, is not known at present and no information is available to the consultant upon which estimates can be made. It is anticipated that under the auspices of the Kuwait Action Plan, information on spill control and clean-up resources will become more generally available. None of the country's oil companies are members of GAOCMAO and hence other oil companies in the Region have no commitment to render assistance in the event of major pollution.

#### Kuwait

National planning for marine oil pollution in Kuwait is currently in a state of change and development. Several government ministries are involved in drawing up a national contingency plan for marine pollution including the Ministries of Communication, Health, Oil and Planning, but specific responsibilities are not at present well defined. Emergency co-ordination in the event of a major oil pollution

incident is temporarily the responsibility of the Ministry of Oil but this situation will change when plans are finalized for the formation of a national environmental committee for pollution control. This latter committee, when established, will be under the chairmanship of the Minister of Health. The operational capability of government agencies to respond to marine oil pollution emergencies with specialized equipment is extremely limited, only the Shuaiba Area Authority/Ministry of Oil having marine craft capable of dealing with oil pollution by means of dispersant spraying.

The operating oil companies provide the major response capability to marine oil pollution in Kuwait and their combined equipment total places Kuwait in second place in the Region's States in terms of maximum potential oil-clearance capacity and in the variety of pollution control equipment available. Kuwait is the only State in the Region to have any oil-recovery equipment (BP Vikoma system) capable of operating effectively offshore, and the country has a greater number of available spray sets than any other in the Region.

Several staff members of the Kuwait National Petroleum Company (Mina Abdulla Refinery) have received formal training in oil pollution control and clean-up technology; periodic training is given by the Kuwait Oil Company to its marine personnel in the use and operation of pollution control equipment.

Three of Kuwait's oil companies are members of GAOCMAO and therefore have the right to request assistance from other member companies in the event of their being faced with an emergency too large for them to handle individually.

#### Oman

Governmental responsibility for oil pollution control in the State of Oman is delegated to the Ministry of Communications acting for the Council for Conservation of Environment and Prevention of Pollution. A co-ordinated national response plan is being developed. Petroleum Development Oman (P.D. Oman) maintains a pollution control watch on the port of Mina Al Fahal by means of company marine craft and there is a limited degree of aerial observation by the civil aircraft using the nearby airport. All reports of oil pollution are relayed to the Oman Government Oil Inspector and spillages occurring within the port of Mina Al Fahal are dealt with immediately by dispersant spraying. Any widespread pollution sighted at sea off the northern coast of Oman is only treated when either facilities or amenities are threatened.

Specialized oil pollution control equipment in Oman is owned by P.D. Oman and this consists of three inshore spray units and one offshore spray unit, all utilizing dispersant concentrate chemicals. A variety of marine craft, including launches and tugboats, would be available for use in case of a major pollution emergency but extra pollution control equipment would need to be acquired or improvised. P.D. Oman has six marine officers fully experienced in the use of the spraying equipment. No capability exists for the clean-up of oil spills by any method other than dispersant spraying.

#### Qatar

It would appear that there is no national marine pollution contingency plan in the State of Qatar at the present time. The oil companies have responsibility for oil spill control and clean-up in the event of major oil pollution. The combined total of equipment from the oil companies comprises seven offshore spray units and two inshore spray units. Both oil companies are members of GAOCMAO and thus have the facility to call upon most other oil companies in the Region for assistance when required.

Qatar Petroleum Producing Authority (Onshore Operations) have several personnel with specialized knowledge of, and training in oil pollution control techniques. Some of these personnel are sufficiently experienced to assume the role of principal pollution control officer, if required, whilst the remainder are competent field operators.

#### Saudi Arabia

A comprehensive oil spill response programme is currently in an advanced stage of planning in Saudi Arabia. The overall authority and responsibility for implementation of the programme is vested in the Environmental Protection Co-ordinating Committee (EPCC) whose members are drawn from all the government Ministries likely to be involved in any incident involving major pollution. The working secretariat for EPCC is the Meteorology and Environmental Protection Administration. This programme is designed to ensure a co-ordinated national response to any pollution emergency which may threaten public health or welfare. The plan allows for the creation of two main centres (one for the Red Sea and one for the east coast) with smaller centres covering the principal ports in each of the main areas. Responsibility for operational aspects will mainly fall on the Saudi Arabia Port Authority and the Ministry of Petroleum in the first instance, but it is possible that eventually the Royal Saudi Navy and Coastguard will also play an active part in oil spill clean-up activities.

As is the case in all other countries in the Region, it is the oil companies which provide the majority of the hardware for use in spill clean-up operations. Some port authorities do have equipment and more is on order, but precise details are not available of what is on hand or planned for the future. The Arabian American Oil Company (ARAMCO) holds the largest stock of oil pollution control and clean-up equipment in the Region, most of it being dispersant spray equipment of one sort or another. ARAMCO is unique amongst the oil companies in the Region in having a full-time oil spill clean-up group dedicated to the task of pollution control in and around the Company's oil exporting terminals.

The equipment held by the Arabian Oil Company at Ras Al Khafji in the Divided Zone further augments the equipment holdings of ARAMCO.

#### United Arab Emirates

All matters concerning the environment of the United Arab Emirates are the responsibility of the Higher Environmental Committee which operates under the chairmanship of the Minister of Health. This committee is composed of senior representatives from all the principal ministries likely to be involved in environmental matters. At the present time, no national marine pollution response plan is available and reliance is placed essentially upon the oil companies of the UAE to afford protection in any situation where major oil pollution threatens, although the UAE Frontier and Coastguard service would offer some assistance.

Within the UAE there are eight operating oil companies which are members of GAOCMAO and which, between them, can put into the field an impressive total of fourteen offshore spray units and six inshore units, plus approximately 500 metres of offshore boom and 300 metres of inshore boom. No equipment is immediately available for any physical recovery of oil, but one set of beach cleaning spray equipment is available.

There is no special "pollution patrol" watch kept either by aircraft or surface marine craft, but obviously operational spills are appropriately reported and dealt with as necessary. Detection of oil slicks entering national waters from outside

sources is dependent upon incidental sightings by helicopters flying in the area or by the various marine craft operating offshore.

A total of sixteen personnel from the various oil companies in the UAE have received specialized training in oil spill control and clean-up techniques, and regular practice exercises are run by some companies in order to ensure that boat crews remain familiar with the dispersant spray equipment.

#### REGIONAL SPILL RESPONSE CAPABILITY

It is obvious that the response capability of the Region as a whole will be the sum of the capabilities of the individual countries of the Region, and these have just been summarized above. The vast majority of the oil pollution control and clean-up equipment permanently available in the Region is held by the operating oil companies with some lesser contribution from various port authorities. The most recent count of pollution control hardware held by those oil companies in the western section of the Region who are members of the GAOCMAO shows that the total equipment holding is as indicated in table 1 below, and an indication of the nominal clean-up capacity available is also shown in this table:

Table 1. Total Oil Pollution Response Equipment held by GAOCMAO Member-Companies

Equipment	Number of Units	Nominal Oil-Clearance Capacity (bpd)
WSL Spray units (inshore)	32	12,600
WSL Spray units (offshore)	40	47,000
Helicopter spray units	4	3,800
Beach cleaning units (spray)	13	4,000
Containment boom	36 = 3,300 metres	-
Oil recovery units (skimmers)	15	35,900
Oil storage barges	8 = 15,600 barrels	-

Additional spraying capacity is available from upwards of ten marine vessels in the Region which are permanently equipped with dispersant spray gear. Few details are available concerning the hardware held by government agencies in the Region but it is improbable that their combined contribution would alter the data of table 1 by more than 10-15 per cent.

The total response capacity indicated in table 1 above appears impressive and, on the basis of the data given, it would be natural to think that the Region is well prepared to deal with an oil pollution emergency of quite a significant scale. A total nominal clean-up capacity of 103,000 barrels of oil per day would seem to be possible if all equipment available in the area were to be mobilized and put in the field. Such a simplistic view, however, does not take into account the many factors which come into play to diminish this apparent response capability.

First and foremost as limiting factors are sea/weather conditions which, in extreme cases, can prevent any form of clean-up operation from being undertaken. Most physical recovery systems are especially sensitive to sea conditions which are in any way rough. Dispersant spraying operations may be conducted in most of the sea conditions experienced offshore in the Region, although the usefulness of such operations in really rough seas is questionable, since natural break-up of surface oil will occur quite rapidly under such conditions without the aid of spraying.

Availability and cost of marine vessels for deploying all the pollution control equipment is a second important limiting factor. If all available equipment was to be deployed at the same time, about 120 vessels/craft of all types would be needed to handle the equipment and provide necessary back-up, etc. The problems of co-ordinating such a large operation would be enormous.

A third factor to be considered is the suitability of the equipment for use in any given situation. For example, table 1 indicates that 15 skimmer units are available in the Region for oil recovery operations but what is not apparent in the data is that only one of these skimmers is suitable for use in the offshore situation, the others being for use only in sheltered inshore waters. One final factor which should not be overlooked is the serviceability of the equipment at any given time. Atmospheric conditions in the Region are such that deterioration of all types of mechanical equipment is rapid if adequate maintenance is neglected. Pollution control equipment is likely to lie idle for long periods of time and there is a tendency to overlook the importance of regular checking and servicing of equipment. This is especially true in the situation where pollution control is only a secondary function of an operating group and tends, therefore, to be neglected owing to the pressure of the other primary tasks. The frequent result of this is that, when pollution equipment is required for emergency use, it is unserviceable and much valuable time is lost whilst overhauls or repairs are carried out. This maintenance factor alone is likely to reduce the immediate nominal response capacity derived from table 1 by as much as 25 per cent or perhaps even more.

The predominant role played by dispersant spraying as a means of oil spill clean-up is very clearly shown in the data of table 1. Part of the reason for this is almost certainly historic in that, during the early days of pollution consciousness in the Region and of co-operation between the oil companies, dispersant spraying was the only clean-up technique of proven effectiveness. The tendency therefore was to build up the co-operative response capability of GAOCMAN around this one technique, and later developments in oil spill control technology were not, in general, considered as being readily applicable in the Region. The reasons for this were many and varied. Primarily it was due to a desire to maintain a singularity and uniformity of approach to spill clean-up by the oil companies with a simplification and standardization of techniques and equipment. Also dispersant spraying was the only known method which had widespread applicability in both nearshore and offshore waters under a wide variety of weather conditions. Another probable factor was a general reluctance to accept the very considerable time and resource commitment necessary to develop the operational expertise which is essential if the various methods of oil containment and recovery, which later became available, were to be successfully applied. Whatever the reasons, the fact remains that the principal response capability throughout the Region relies upon dispersant spraying, and a formidable array of spraying equipment is available in the Region for use when required.

A variety of oil booms are available from a number of the oil companies in the Region. A total of some 3,300 metres of boom can be assembled, almost 2,000 of which is Vikoma Seapack suitable for oil containment and recovery use offshore in conjunction with appropriate skimmers. There is little, if any, practical



experience in the use of booms in a containment/recovery mode in the Region and in spill emergencies the booms would be used principally in a deflection mode to protect vital facilities and amenities. Some of the boom which is available is of use only in sheltered waters and would be used inside harbours or similar areas. Like much of the mechanical equipment, booms are subject to deterioration and it is questionable just how much of the amount of boom nominally available in the Region would actually be in serviceable condition when required.

Any offshore oil recovery operation will require mobile temporary storage equipment for intermediate storage of recovered oil prior to disposal. GAOCMAO member companies have eight oil storage barges which could be used for this purpose, and the Arab Ship Repair Yard in Bahrain has a 32,000 DWT tank-cleaning tanker (not self-propelled).

In addition to these vessels there would be many other small bunkering vessels which could be made available in a serious emergency if a major physical recovery operation were contemplated.

Apart from equipment availability which has been discussed above, Regional response capability is dependent upon the degree of co-operation and co-ordination which exists between the various concerned agencies in the Region. The highest level relationships are those between national Governments and governmental bodies in the Region. Such relationships in regard to oil spill response are not well developed and much is required to be done to improve the situation. At the operations level, this deficiency in inter-governmental co-ordination frequently manifests itself in delays in moving urgently needed equipment and personnel across national boundaries, etc., and several days may be lost whilst Customs and immigration formalities are sorted out. In the view of the consultant, the most effective co-operative organization in the area studied is GAOCMAO. A very efficient communications network has been set up between the member companies of this organization, and the very personal level of contact which exists between the various company representatives of GAOCMAO has proved invaluable over the ten years since the organization was first formed. However, the primary function of GAOCMAO is not to develop a Regional response capability to oil pollution but essentially to ensure that individual member companies have a back-up capability to deal with oil pollution incidents which are beyond their individual capacity to handle.

Oil spill clean-up contractors have a role to play in increasing the capability of the Region to respond to oil spills. There are several companies in the USA and Europe which offer a world-wide response capability to oil pollution emergencies but none, as yet, has established a permanent operating base in the Region. The result of this is that several valuable days may be lost before any of these contractors can become operational in a major spill in the Region. Since most of these contractors utilize mechanical recovery systems as a major part of their service, the loss of these early days greatly reduces the overall effectiveness of their operations. One oil spill clean-up contractor is known to the consultant to be in the process of establishing an operational base in the Region.

#### DISPERSANT CHEMICAL SUPPLY IN THE REGION

It has been shown above, in theory at least, that it is possible to put in the field a total spraying capacity equal to an oil dispersion capability of almost 64,000 barrels of oil per day. This level of spraying activity would require a daily dispersant usage of 450,000 litres, assuming that concentrated dispersant only

was used. There would be little purpose in having an equipment capability of this magnitude if it could not be matched by a dispersant supply capability of approximately equal magnitude. A significant stockpile of dispersant concentrate chemical is maintained in the Region, principally by the oil companies operating there. This stockpile probably amounts to about 2 million litres in all at any given time and this is equivalent to four or five days' supply, at maximum usage rate. In practice this stockpile would initially last considerably longer than this, since it would probably take several days to mobilize the maximum spraying effort, if such was ever required.

The limiting situation to consider in terms of dispersant supply is where the stockpile has been totally depleted and the sole continuing source of fresh dispersant is that being supplied directly by the manufacturers. If we assume that the necessary transport situation can be resolved, then the deciding factor is the ability of the manufacturers to produce the dispersant chemical in the required quantity. The daily manufacturing capability of the principal dispersant manufacturers in Europe and the USA is detailed in table 2 below.

Table 2. Dispersant Chemical Supply Capacity - Principal Manufacturers

Manufacturer	Product	Supply Capacity (litres per day)
Dasic International	Slickgone LTE	100,000
Essochem	Corexit 9527	125,000
Gamlen	OSR 2000	30,000*
Petrofina	Finasol/OSR 7	130,000
Servo	CD 2000	50,000

\* Manufacturing capacity of Kuwait plant, not a concentrate.

These data indicate that it is probable that the total capabilities of all manufacturers to supply dispersant concentrate to the Region over an extended period of time can only just match this theoretical maximum usage rate. This situation is not as serious as may at first appear because, for reasons stated previously, it is most unlikely that the full spraying potential of the Region will ever be realized in practice. However, the above considerations do highlight the fact that, on an overall Regional basis, the level of dispersant spraying capability is probably at an optimum, and that any further increase is unlikely to be of any significant value. Further improvements are likely to come from an upgrading of operational efficiency as a result of operator training and experience, and replacement of old and obsolete equipment.

#### COMMENTS ON POSSIBLE FUTURE ACTIONS AND ROLE OF MEMAC

The data presented above indicate that at the present time it is the oil companies of the Region which provide the main capability to respond to offshore oil spills and that this capability is heavily biased towards the use of dispersant chemicals. Experience in the use of oil recovery systems is generally lacking both in the governmental agencies and oil companies and only one company currently has

any recovery equipment which can be used offshore. Oil containment and recovery systems are expensive to buy and require a high level of competent operation by personnel if they are to perform satisfactorily and this can only be attained by thorough training and continuous practice. In the opinion of the consultant, permanent commitment of marine craft and personnel to oil pollution control operations is necessary in such instances.

The essential role of oil companies is to produce oil and oil products. It is perhaps unreasonable to expect them to expand resources to maintain dedicated oil spill response teams which would be involved in major oil spill clean-up only on rare occasions. In general, the present level of pollution response capability maintained by the oil companies is sufficient to deal with the day to day spills which occur as a result of normal routine operations. Their combined response capability in terms of dispersant spraying probably does not need to be supplemented further by Governments of the Region except to protect local facilities. It is suggested that it should be the role of Governments, either individually or collectively, to undertake the task of providing the manpower and equipment resources necessary to set up and maintain a full-time oil spill response function, based on physical containment and recovery, and which is capable of dealing effectively with the occasional large spills which affect the Region. The proposed Marine Emergency Mutual Aid Centre (MEMAC) would seem to be the ideal vehicle through which such a response could operate.

Another area of operation requiring improvement in the Region is that of oil slick surveillance and reporting generally. According to the information available to the consultant, no formal "pollution control" watch is maintained in the Region. Reports of oil slicks depend upon the casual observations of mariners or aircraft pilots traversing the Region during their everyday operations, but there exists no central reporting and recording system for such observations. It is suggested that Governments should institute a daily helicopter survey of all the principal offshore areas at risk, in order to monitor oil pollution. It is further suggested that all reports of significant oil pollution should be transmitted immediately to MEMAC (when the latter is functioning) and that MEMAC should then use these spill reports to compile reliable spill statistics for the Region. It would be a further responsibility of MEMAC to assess each report and to decide whether any spill is of such consequence as to require other Governments in the Region to be informed of a possible pollution risk. Upon agreement as to how best to deal with it, a MEMAC response team could then be deployed to start clean-up operations. That MEMAC should be able to respond to spills on its own initiative is highly desirable, since rapid response is one of the key factors in successful clean-up operations.

To conclude this paper, the following suggestions are offered for a few of the other roles which MEMAC might play in the Region:

- a) Central information body, maintaining up-to-date information on all matters relating to marine pollution, including developments in oil spill control technology, current materials and equipment available, contractor response agencies available etc., etc.;
- b) Central testing and evaluation body for spill equipment, materials, etc., to evaluate new and existing equipment/materials for effectiveness under conditions prevailing in the Region; MEMAC could develop some "approval" system to assist government agencies, etc., in obtaining the most appropriate equipment;
- c) Provide Regional co-ordination and resource facilitation during oil spill emergencies;

- d) Provide technical expertise on all matters relating to marine pollution in the Region;
- e) Provide training facilities in oil spill control and clean-up techniques specifically tailored to the needs of the Region and maintain a marine emergency task force available on a 24-hour basis for response to spill emergencies;
- f) Effectively interface with all oil companies in the Region and maintain close contact with GAOCMAO.

ARAMCO OIL SPILL PREVENTION AND RESPONSE PROGRAMME

by  
J.E. Cuddeback and Khalid Al-Qatari

Arabian American Oil Company,  
Dhahran, Saudi Arabia

ABSTRACT

ARAMCO has stressed the prevention of oil spills since it first began producing and exporting oil in 1938. Spill prevention has taken two forms: 1) application of the best practical engineering technology and 2) stringent operating controls and training. Realizing, however, that accidents do happen even with the best engineering and strictest controls, ARAMCO has created a response organization to combat oil spills in the event of a release of oil on water or land.

The prevention of oil spills begins with drilling operations and continues right through to the departure of the laden tanker from the terminal. ARAMCO has had only two blow-outs in 30 years of offshore operations. Pipelines and flowlines in offshore areas are all cathodically protected and undergo regular visual inspection by divers. As a result of such measures, there have been only three offshore pipeline ruptures in 30 years. Producing platforms are designed to limit operational discharges. Terminal facilities are operated in a way that minimizes the possibility of small or large oil releases. The SBMs have frequent hose renewals and the Sea Islands, special slop handling facilities.

In addition to preventive measures, ARAMCO has developed a contingency oil spill plan, a full-time pollution response unit and an inventory of specialized equipment. The response is based on keeping the oil from sensitive areas and carrying out clean-up operations at sea with the use of dispersants. There are at least ten vessels fitted out with spraying apparatus. ARAMCO also has the equipment for aerial application of dispersants. Special plans are made for spills where dispersants cannot be used. Booms and skimming equipment are kept on hand for such cases.

## REPORT

In order to put the ARAMCO oil spill prevention and response programme into perspective the size of the effort must be considered first:

Figure I shows some ARAMCO production statistics for 1979. As can be seen, an average of 9.25 million barrels per day were produced of which about 30 per cent or 2.7 million barrels per day were from offshore fields.

Figure II shows the distribution of the offshore producing areas in relation to the coastal areas. The distance between Zuluf in the north and Abu Safah in the south is about 210 km.

Figure III shows offshore well and drilling statistics for 1979.

Figure IV shows the 1979 Terminal activity.

These four figures illustrate the potential for oil spills merely in the portion of the Kuwait Action Plan Region in which ARAMCO operates. To put this in a somewhat different perspective, figure V illustrates the oil imports of western Europe. Saudi Arabia produces almost as much oil as western Europe imports. The dots on figure V mark the locations of major spills in the past 15 years. There are 18 dots representing 585,000 tonnes of spilled oil. The potential problem for tanker-related oil spills along the Saudi Arabian coast can be said to be in the same order as western Europe, since the ARAMCO exports are in the same range as European imports. Add to this the potential of spills from production and it becomes apparent that a comprehensive oil spill strategy is needed. ARAMCO has long recognized this need. From the moment a drilling operation starts to the departure of the laden tanker from the terminal, prevention of spills has been a guiding principle of the Company.

The comprehensive prevention programme has proved largely successful. During the last 30 years, there have been only two offshore oil well blow-outs in Saudi Arabia and only one of these caused significant oil pollution. This enviable record is due to the preventive measures taken. For example, in all the drilling operations undertaken by ARAMCO, crews are highly trained in carefully defined procedures. The crew on all ARAMCO contract rigs are required to attain certain personnel experience levels. In addition, there is an ARAMCO engineer on each contract rig whose job is to see that the drilling is carried out in a safe and reliable manner that meets Company specifications for pollution control, inspection of safety equipment and overall supervision of operations. The drilling is all carefully planned prior to moving the rig on site, and this planning includes a review of seismic data and other geological information to predict potential problems.

It has been and continues to be an ARAMCO policy that every precaution be taken to ensure that a well remains under control at all times. This strict maintenance of well control often slows down drilling operations and increases costs. But the dividends in decreased risk of pollution and of costly blow-outs make it worth while. A vivid illustration of the impacts and costs associated with a blow-out was the recent Ixtoc-1 blow-out in Mexican waters. At ARAMCO all efforts are being made to ensure that such an incident does not occur in the Region. For example, in addition to the strict well control procedures mentioned earlier, ARAMCO completes all wells above the surface, that is, on a platform. This has distinct advantages. In the event of a blow-out there is a good chance that the well can be ignited and the oil and gas burned instead of spilled into the water. This was demonstrated

# 1979 OIL PRODUCTION

MILLION BARRELS PER DAY



Figure 1

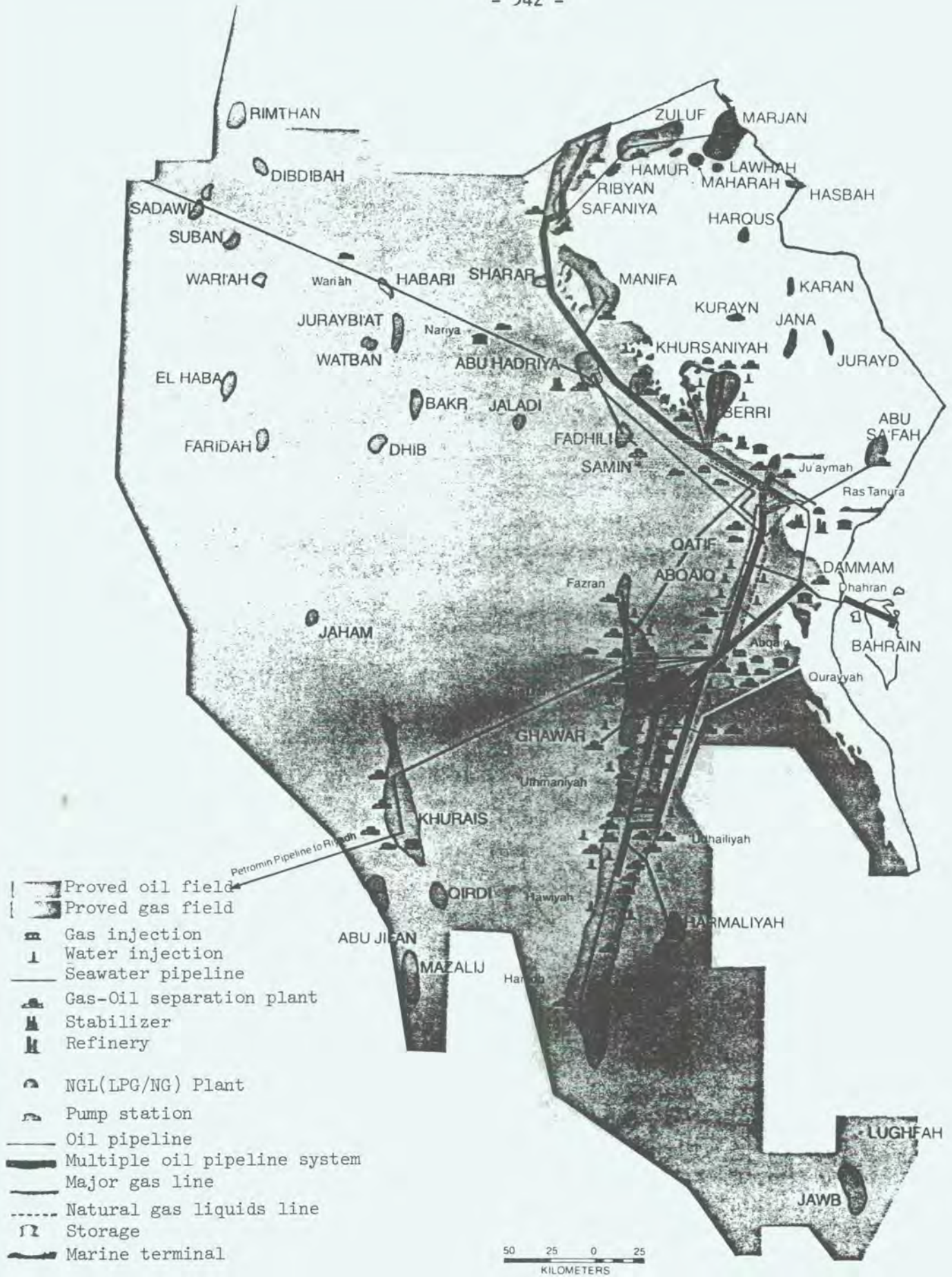

Figure II



# OFFSHORE ACTIVITY 1979

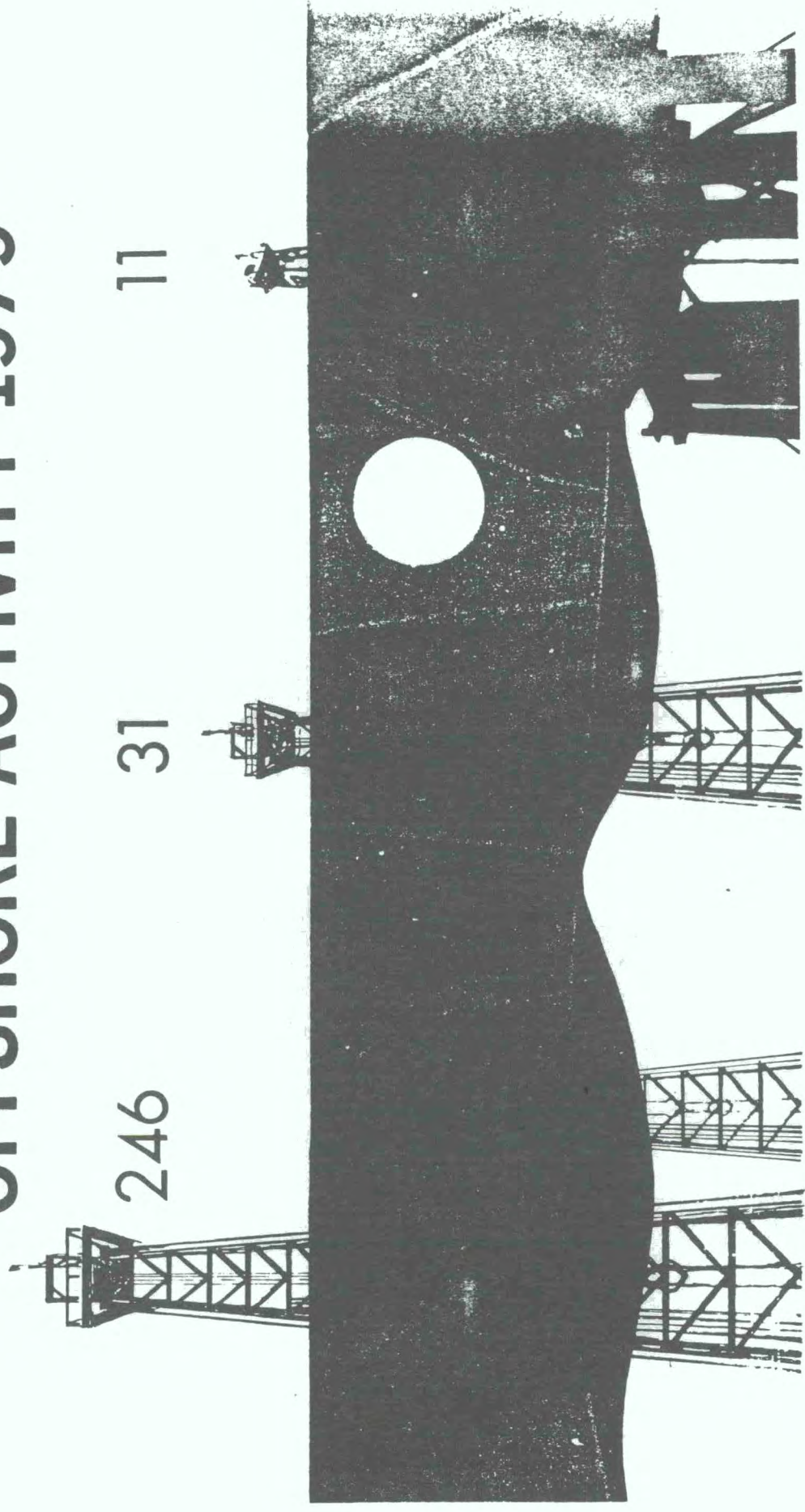

Figure III

**PRODUCING  
WELLS**

**NEW  
WELLS**

**ACTIVE  
RIGS**

# TERMINAL ACTIVITY 1979

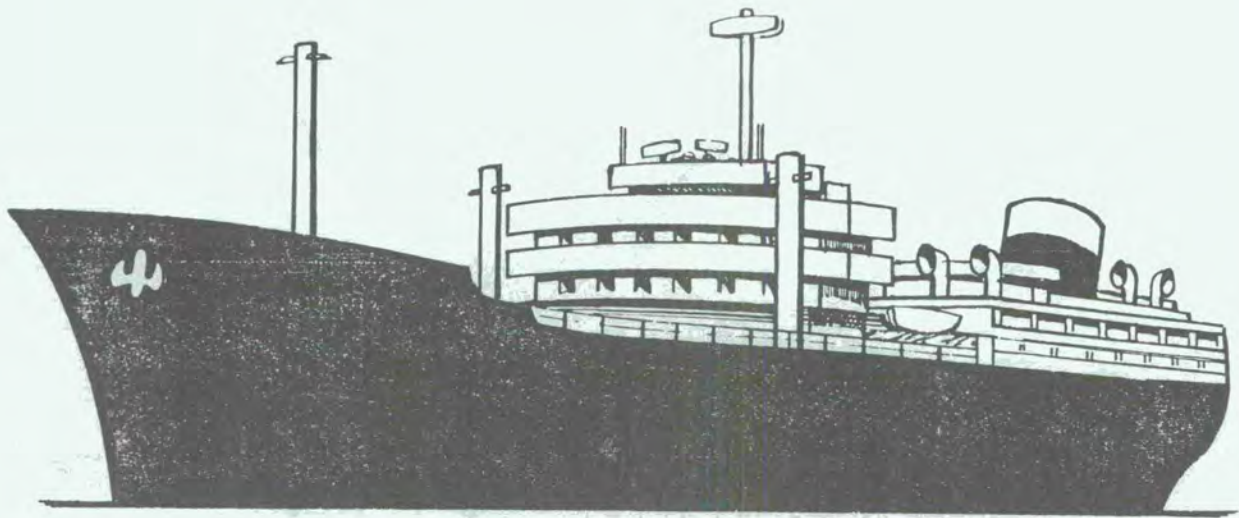

3,861 BERTHING

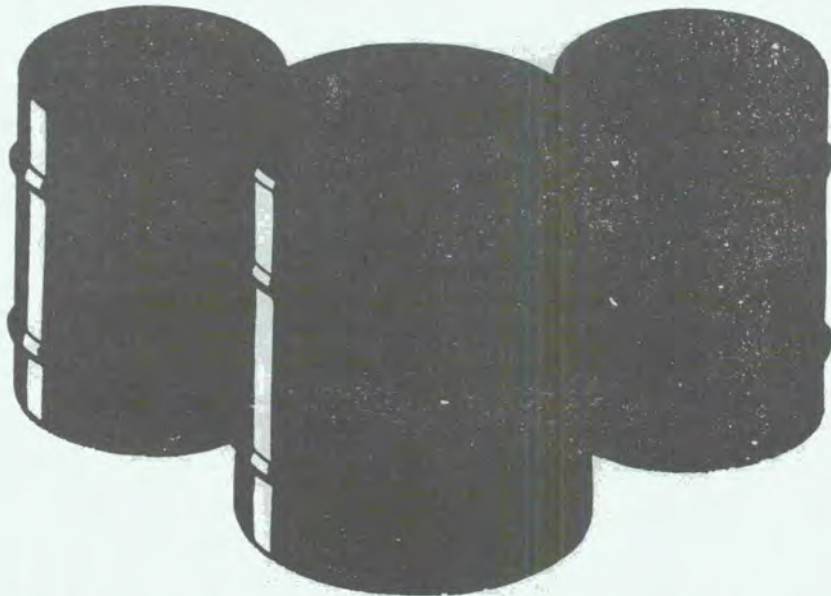

8.3 MILLION BARRELS PER DAY

Figure IV

# EUROPEAN OIL CONSUMPTION AND SPILLS



Figure V

recently in the Berri oil field where a blow-out on a six-well platform resulted in only a small amount of oil on the water during the two months it took to quench the well. A subsurface completion, such as the Ixtoc well, spills oil directly into the water when it blows and thus is inherently a much greater pollution threat than the above-surface completions.

However, even with the best possible preventive measures, there is always the chance of a blow-out, as happened with the Ekofisk well in the North Sea, the Ixtoc-1 well in the Bay of Campeche and the Hasbah-6 well in the Kuwait Action Plan Region. In order to react to such a situation, ARAMCO has carefully logged each well, pinpointing both the surface and down-hole locations. ARAMCO has also noted each well's performance characteristics and formulated a plan for the placement of relief wells. Thus, when the Berri Well No. 34 went out of control, two rigs were immediately rushed to the scene and within 60 days were able to kill the well. This could not have been accomplished without forward planning and an accurate knowledge of the down-hole location of the well. It should be borne in mind that it took more than eight months to cap Ixtoc-1 and only after millions of barrels of oil had been spilled.

The preventive measures do not stop with drilling. Each completed well is protected with two failsafe valves. The platforms are designed to meet more severe weather conditions than are likely to occur in the area, and both the platforms and pipelines are cathodically protected from external corrosion. ARAMCO's pipeline specifications are the most stringent in the world when wet or sour service is anticipated. In fact, when these specifications were first laid down, no supplier would bid on the pipe contracts. Even the specifications for normal crude service are stricter than those set by the American Petroleum Institute. With 855 km of offshore production pipeline, ARAMCO has to be rigorous.

At the same time, the Company is looking ahead, anticipating the possibility of new pollution hazards. For example, as the oil fields begin to go wet, the potential for internal corrosion will increase, so steps are being taken now to respond to this new problem. Designs are being made for corrosion control chemicals to be injected at the well head. New flowlines and pipelines in severe service areas will be required to have an internal coating of polyurethane or epoxy.

ARAMCO's preventive measures continue when the oil comes ashore from the offshore wells and production platforms. Many spills are caused in and around marine terminals; consider, for instance, the Bantry Bay incident, the tank failure at the Shell terminal in Nigeria or the many smaller spills of 100 to 200 barrels that occur each year in terminals all over the world. As the world's largest terminal operator, ARAMCO is well aware of the potential for spills in these areas.

Figure VI gives some of the tankage figures for the ARAMCO terminals. It can be seen that at any one time there can be up to 37 million barrels of oil stored within one kilometre of the shoreline. Where there is oil stored there is the potential for a spill, so again prevention is the key. Each tank is individually diked and the diked area is drained to an impoundment area. The system is designed to hold the contents of the terminal's largest tank, thus preventing an oil release into the sea.

From the tanks the oil must be transferred to the tankers, and it is during this operation that there is an increased danger of oil spill. At the Ju'aymay Terminal, oil is pumped at up to 130,000 barrels per hour so that even a small leak could result in a large quantity of oil being released. In order to reduce this risk as much as possible, very strict operational and inspection standards are maintained. To begin with, all hoses are regularly inspected and overhauled.

# TERMINAL CRUDE OIL TANKAGE

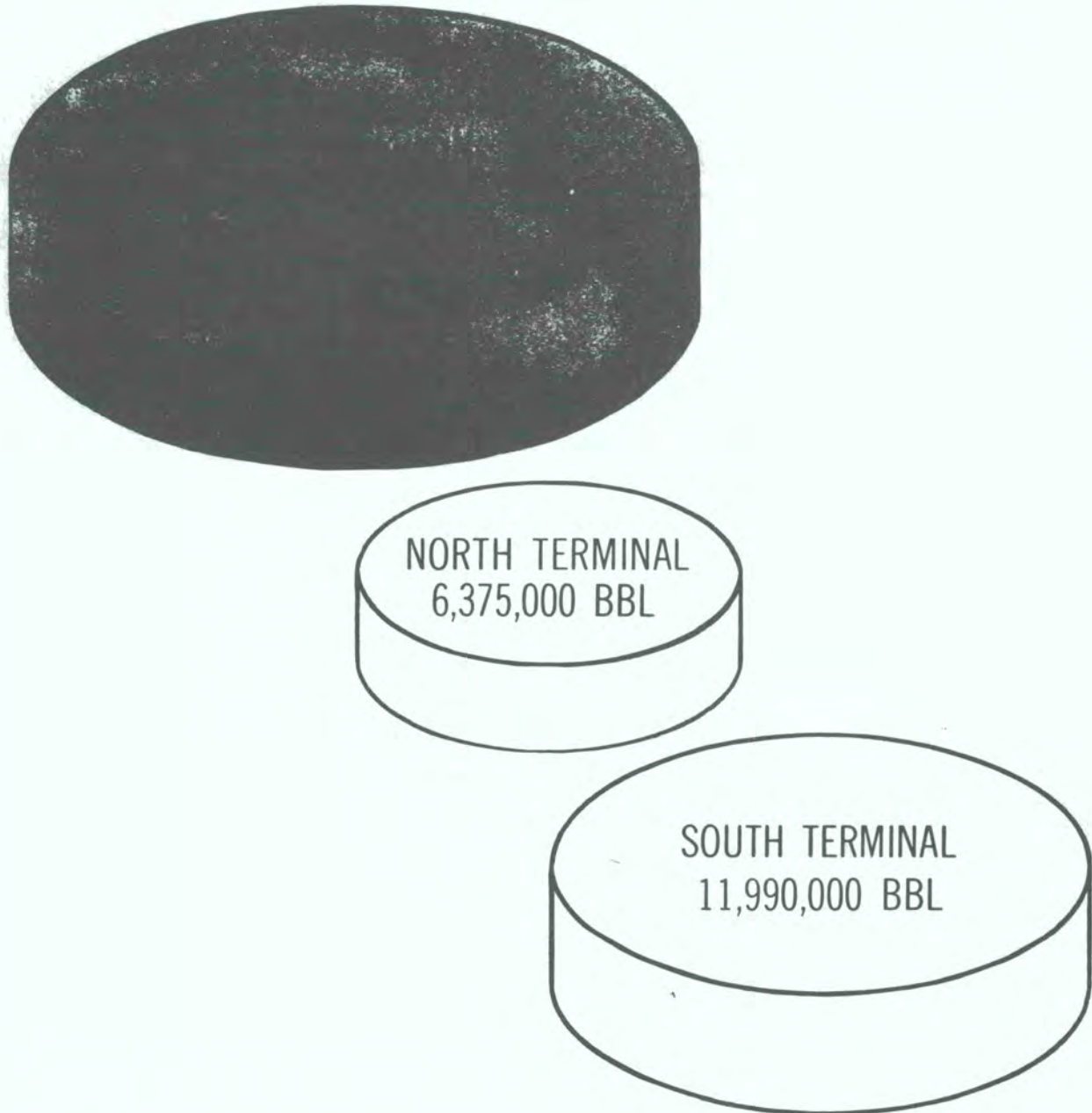

**TOTAL 37,883,000 BARRELS**

Figure VI

Currently, the surface hose string on SBMs is changed every 12 months and the subsurface string is changed every 24 months (though this may soon be reduced to 12 months also). During an overhaul, the hose string is subjected to a bend or stiffness test, a visual inspection, a vacuum test at 630 mm Hg and a 100 per cent pressure test. Divers also carry out regular inspections on the hose couplings and flanges while in service so that small leaks can be detected before they grow larger. Similar inspections and tests are carried out at the Sea Island terminals.

Preventive measures are in force at both the Ju'aymah Terminal, where the SBMs are located, and the Ras Tanura Terminal, where the Sea Island and Piers are situated. A loading plan is established during discussions between terminal personnel and the offtaking vessel personnel. This loading plan covers the critical loading rates that are to be used and the topping off rates that can be expected. Actual loading operations are carried out with every care normally associated with terminal operations.

So far only prevention has been discussed. ARAMCO also has a response capability. In fact, oil spills and oil spill response are viewed in much the same way as fires and fire fighting. While ARAMCO does all it can to prevent fires, it still maintains a vast amount of equipment and manpower devoted to fighting fires that we hope will not occur. Similarly, while prevention of oil spills is a basic tenet of the company, spill recovery and clean-up are not neglected. It is well known that even under the most rigorous of engineering and operational safeguards there will be accidents. What happened at the Three Mile Island nuclear plant in the United States in one of the most highly engineered and regulated industries in the world may be quoted as an example. Accidents will happen and preparations must be made to meet them.

ARAMCO has prepared for oil spills in four ways: 1) response planning, 2) equipment development, 3) training and 4) developing and strengthening the Gulf Area Oil Companies Mutual Aid Organization (GAOCMAO). The planning aspect had to come first in order to develop an adequate response to an oil spill. Planning included developing a basic philosophy or policy of spill control, deciding on the size of spill to which the response preparations should be geared, setting up an organization to respond to a spill when it occurred and detailing as much as possible what had to be done in the event of a spill. It must be remembered, however, that each major spill is unique, and planning, no matter how thorough, cannot cover every conceivable contingency.

ARAMCO's policy on spill control has been established for a number of years. It is based on three principles: 1) protection of human life, 2) protection of critical facilities and 3) protection of the environment. Only the second part of this three-pronged policy needs further comment. Many spill response plans do not actually state that protection of critical facilities is a basic requirement, but because of ARAMCO's unique role in world oil production, this point has been specifically identified as an integral part of the company's spill control philosophy. Loss of a major facility due to a spill could have severe repercussions on world oil supply as well as cause economic losses to the Saudi Arabian Government. This is why protection of facilities is stressed.

As mentioned previously, everything about ARAMCO's operations is exceptionally large: tonnage shipped, tankers loaded, offshore pipelines, etc. The potential spill size could conceivably be 3 to 4 million barrels if two tankers collided. This, however, is a highly unlikely event and one does not plan a spill programme to meet such an occurrence; indeed the whole of western Europe could not handle a spill of such magnitude. Instead, the decision was made to be able to control a spill in the 50 thousand barrel range. This decision was based on likely losses

through a damaged loading hose, a wing tank of a VLCC, an offshore trunkline or a well blow-out at five to ten thousand barrels per day. These are the types of spills that are far more likely to occur than a catastrophic tanker accident like that of Amoco Cadiz.

With the philosophy of the spill control laid down and a limit placed on the magnitude of spill that should be dealt with, a response organization was developed. The concept used was to structure the organization so that it could handle both large and small spills. The organization was therefore compartmentalized both vertically and horizontally, so that only certain segments would be activated for smaller spills. An organizational diagram is shown in figure VII. Each block represents a specific function which has been detailed in a response manual. In other words, there is a job description for each block in the diagram, with an individual and an alternate assigned to each function. These assignments are fed into a computer and given a quarterly update to reflect personnel changes.

The particular Department or Business Line at whose facility a spill occurs is responsible for the clean-up operation, although the actual clean-up may be carried out with the assistance of a large number of diverse departments. This responsibility moves higher up the company's management hierarchy as the spill size increases. For example, the entire clean-up for a 20-barrel spill may be handled at the foreman level, whereas a 25,000 barrel spill would involve the Administrative Area Vice-President together with the representatives of various support organizations. This is the vertical compartmentalization mentioned earlier. The oil response teams shown in figures VIII and IX illustrate how the organization would be activated in different spill situations.

The spill response plan also includes the Oil Spill Task Force whose members provide the high-level authority needed to support an oil spill response at the expense of other operational activities. Normally, the Task Force duties are assigned to a representative of the Administrative Area Head during an oil spill. In addition, the Task Force acts as a management group for ARAMCO's overall spill prevention and clean-up programme. Individual Task Force members make sure that their respective organizations are prepared to do their assigned part when called upon in an emergency.

The final aspect of the response plan is a general description of what actions to take in the event of a spill. As already mentioned, each spill is unique so that all possible scenarios cannot be planned in advance. However, general cases can be outlined and guidelines formulated to help the response team. These are spelled out in the ARAMCO Spill Response Manual, which details reporting procedures, equipment inventories, contractor information, spill trajectory forecasts and other information techniques. Let us illustrate one or two items from the Spill Response Manual.

One of the planning items in the manual is oil spill trajectory estimates. A set of spill trajectories has been modelled for ARAMCO installations by the University of Petroleum and Minerals Research Institute. Figure X shows the information supplied by one of the scenario models. This type of information helps to locate areas where equipment must be made available quickly, to identify the most vulnerable areas and to estimate the timing of the impact of a spill. The spill trajectory maps are useful reference items in the event of a spill, and quite frequently they can be used to disburse men and materials in the most effective way. Other planning tools in the Spill Response Manual are the coastal vulnerability maps. Figure XI illustrates one of these maps for a part of the coast south of Jubail. The different shades indicate different vulnerabilities. The vulnerability index used for Saudi coastal waters is shown in figure XII. The area

# OFFSHORE OIL SPILL RESPONSE TEAM

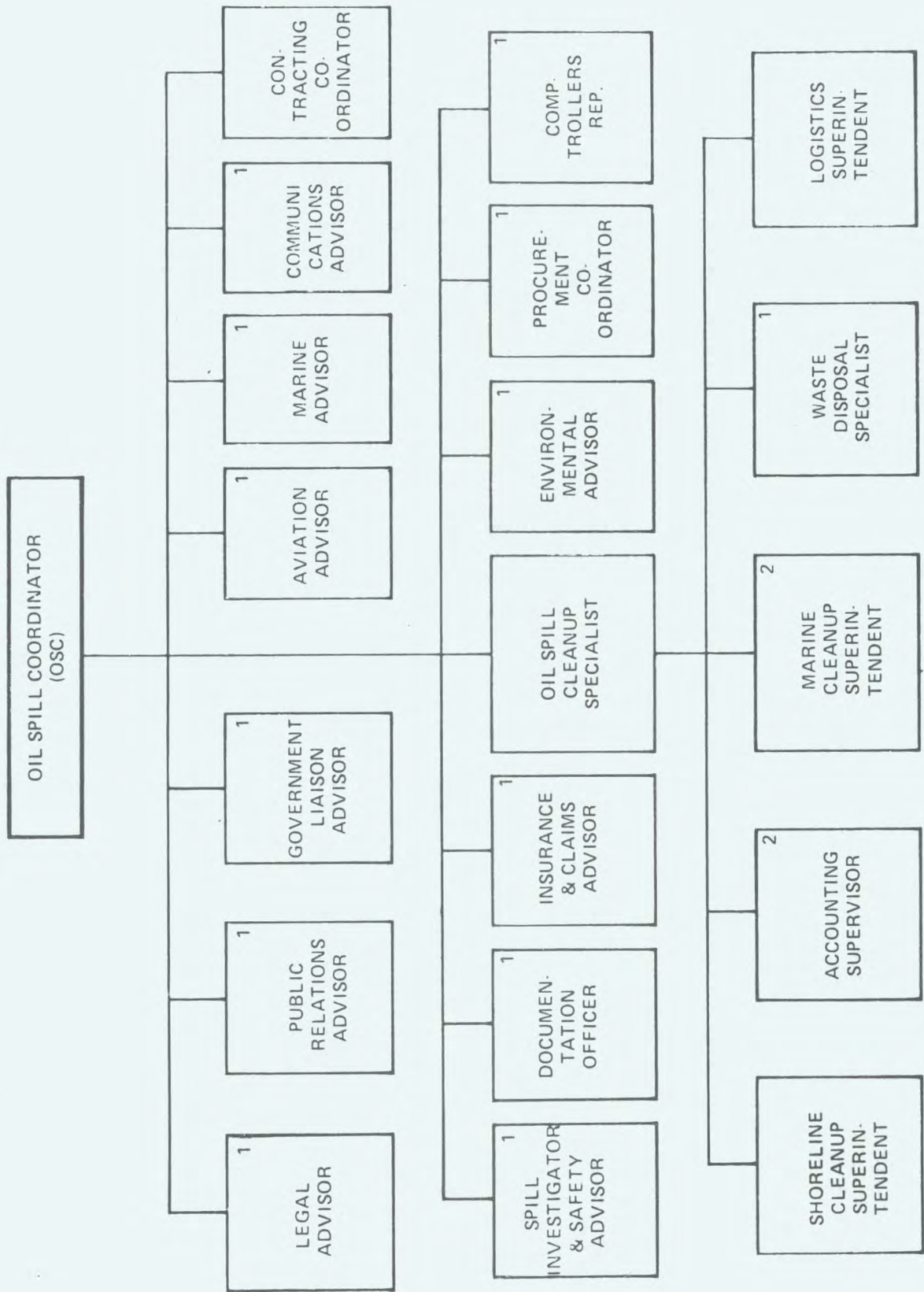

Figure VII



# OFFSHORE OIL SPILL RESPONSE TEAM

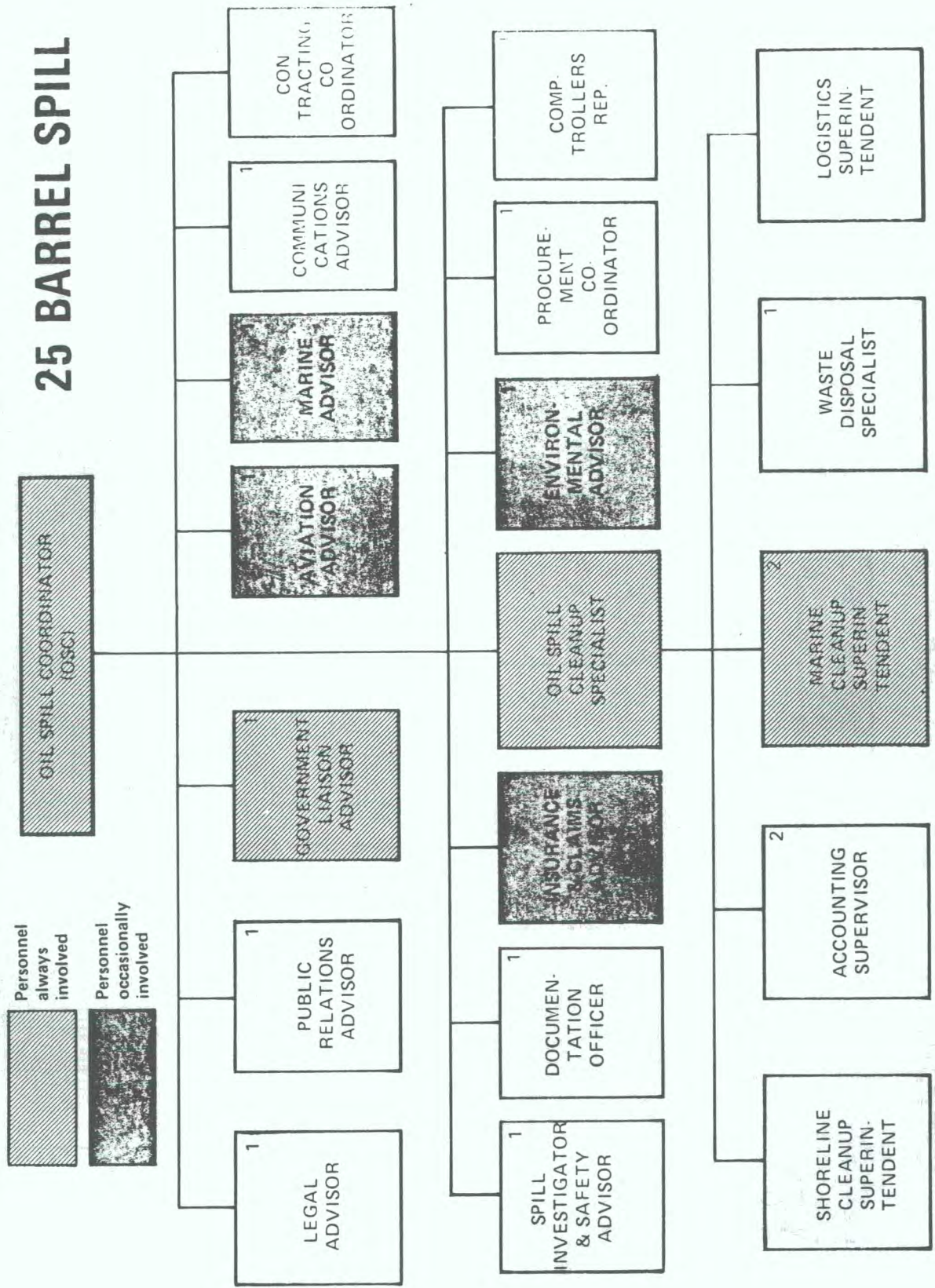

Figure VIII

# OFFSHORE OIL SPILL RESPONSE TEAM

## 25000 BARREL SPILL

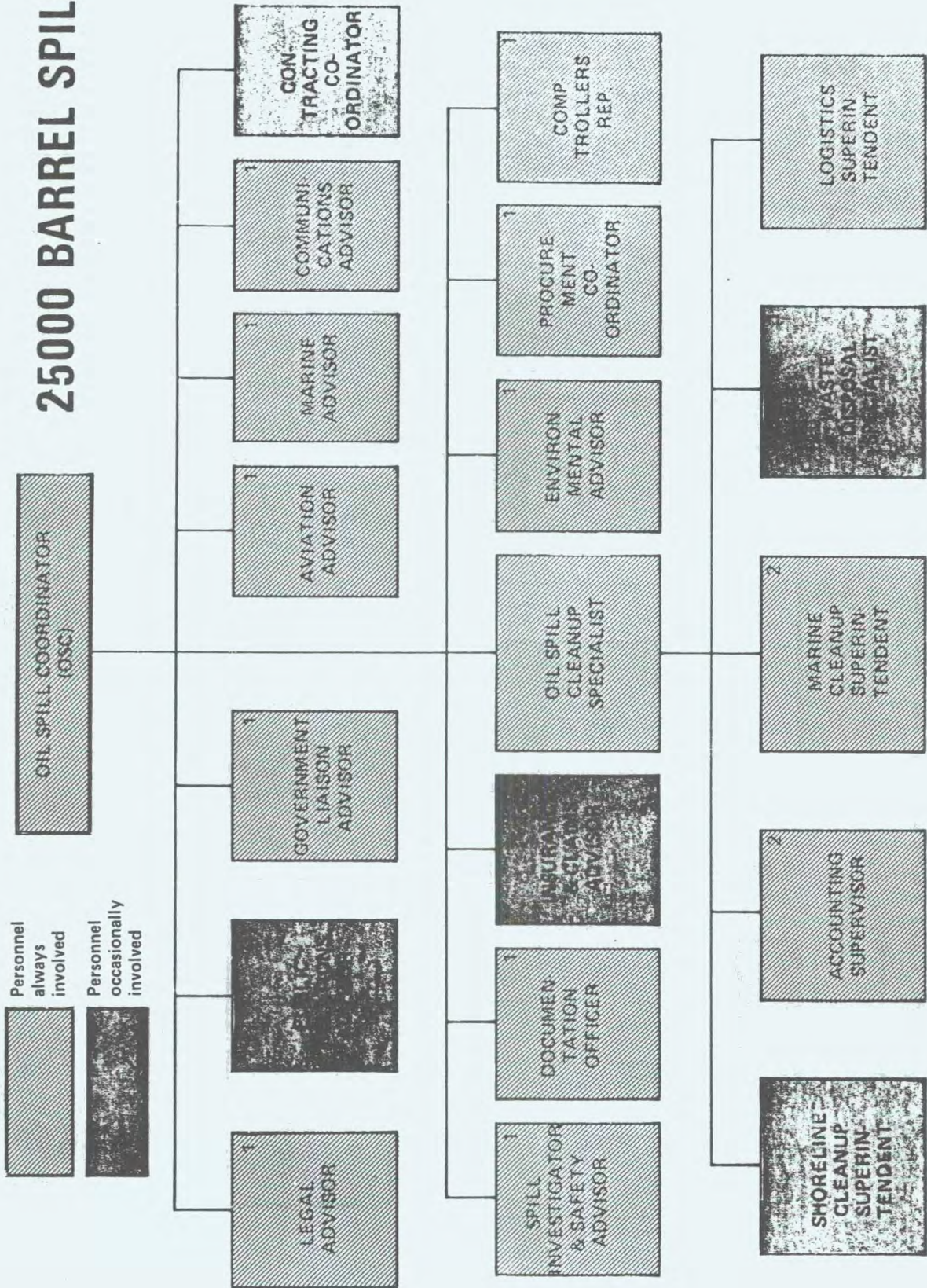

Figure IX

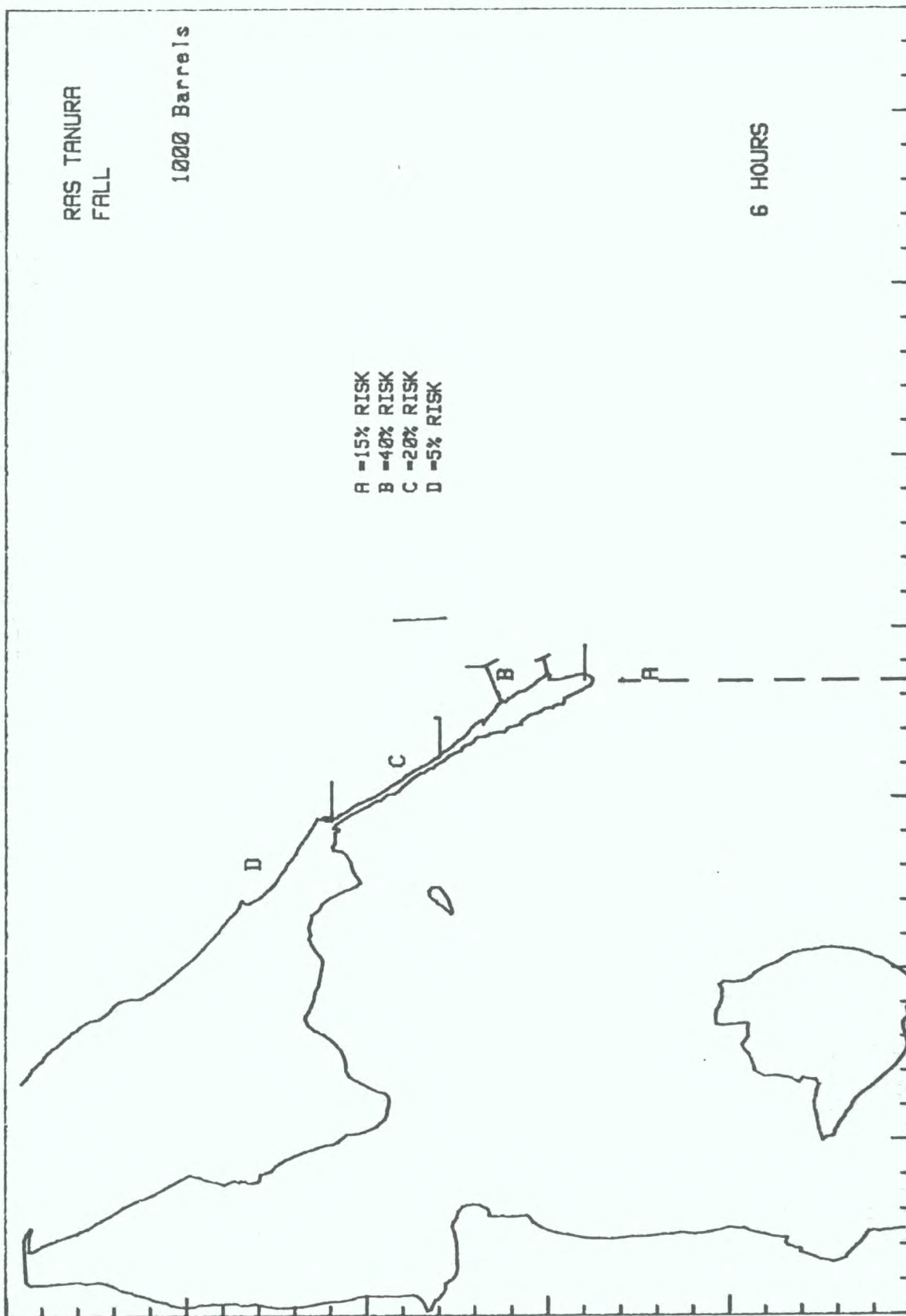

Figure X

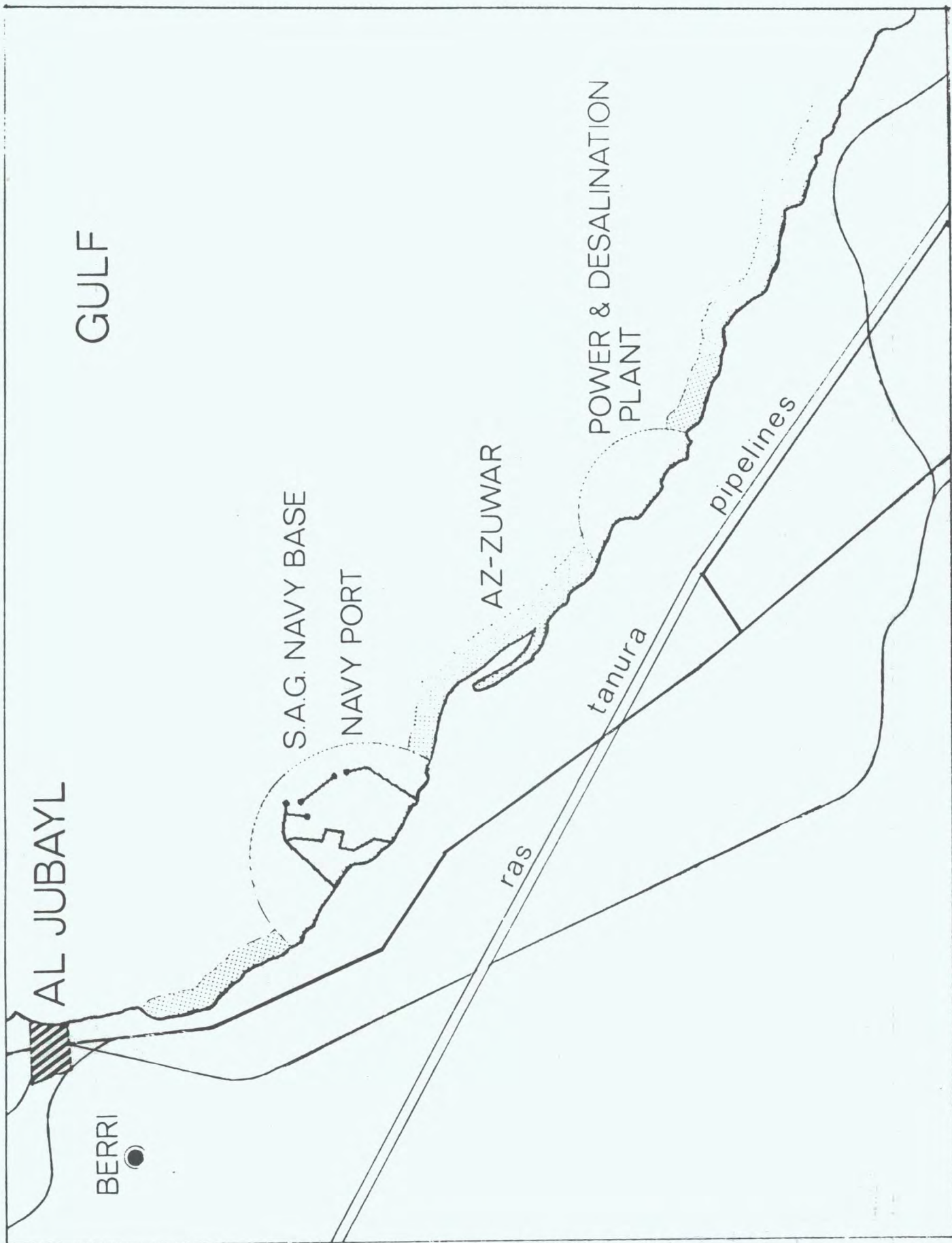

Figure XI

COASTAL VULNERABILITY INDEX







COASTAL TYPE	VULNERABILITY	REMARKS
MANGROVE MARSH	1 	MOST PRODUCTIVE COASTAL AREA. SENSITIVE TO OIL
OFFSHORE ISLANDS	2 	CRITICAL TO GULF ECOLOGY NESTING LOCATION FOR THREATENED SPECIES. OILED SHORELINE EFFECTS BIRDS AND TURTLES
MUD FLATS	3 	PRODUCTIVE AREA SUBJECT TO HARM IF DISPERSANTS USED IN SHALLOWS
CORAL REEFS	4 	PRODUCTIVE AREA SUBJECT TO HARM IF DISPERSANTS USED IN SHALLOWS
MUDDY SAND	5 	MODERATELY PRODUCTIVE. PREVENT OIL FROM PENETRATING SAND
ROCKY BEACHES	6 	LOW TO MODERATE PRODUCTIVITY HARD TO CLEAN
SAND BEACHES	7 	LOW BIOLOGICAL PRODUCTIVITY

Figure XII

immediately north of Jubail is shown in figure XIII and it can be seen that this is a much more varied area with considerably higher vulnerability. These maps have been used to plan strategies for spill control. They identify, for example, the location of the various water intakes as well as ecologically sensitive areas. It would require a maximum effort to ensure that oil would not impact such areas. Booms would be used to divert the oil and operations would attack the slick far enough offshore to prevent oil from reaching the high vulnerability areas.

A response plan by itself cannot clean up spilled oil. Men and equipment are needed for that. Some of the men were already mentioned as part of the organizational description. As for the equipment, ARAMCO's current planning philosophy stresses the use of dispersants as the chief weapon in the response arsenal. Containment and recovery are used only in specialized cases. Therefore, the greater part of ARAMCO's equipment development efforts has been devoted to the delivery of dispersants. The rationale for relying on dispersants was based on analyses of past oil spill responses in Saudi Arabia and elsewhere. Historically, recovery operations in open waters have not been very effective and required much more technical expertise, manpower and equipment than dispersing methods. There have been no serious environmental effects shown to be associated with the use of the new low-toxicity dispersants. They are easy to use, very efficient and ARAMCO has found them adaptable to a wide variety of circumstances.

Dispersants are generally applied by marine craft or aircraft. The efficiency of a dispersant depends on its chemical characteristics, the temperature, type and thickness of the oil, and the application rate. At ARAMCO we have generally used application rates of 5 to 7 gallons per acre on oil which has been on the water for several hours and has completed its initial rapid spread.

When the oil is thick or does not appear to disperse after treatment, the application rate is increased. The dispersant can be relied on to disperse from 5 to 10 times the volume of oil, depending on the factors mentioned above. For planning purposes, a 1 to 10 ratio is used.

ARAMCO has developed both aerial and marine craft dispersant application capabilities. At least ten ARAMCO marine craft are always equipped for dispersant spraying operations. They range in size from a small 23 ft boat to a large harbour tug of 243 ft. Many of the vessels are equipped with dispersant tanks holding from 200 gallons to 20,000 gallons. Pumps, eductors, hoses and booms are part of the permanent equipment on these vessels. Table 1 gives a list of the current vessels and pertinent data. Table 2 shows two vessels listed with some details on their efficiency. As can be seen, some of the vessels are at present only suitable for small spills or initial attack on large spills. ARAMCO is undertaking a modernization of the marine craft dispersant systems. This will increase the tank size, boom width and application rates on a number of the vessels.

The marine craft application of dispersant can be quite effective when used quickly and tactically. Many of the likely spill sites are within a half-hour to one-hour trip of one of the dispersant-equipped vessels. This means that they can be on the scene and spraying before the oil has a chance to spread appreciably, and long before specialized craft with booms and skimmers can be mobilized. With newly ordered equipment the dispersant dosage can be adjusted to apply the dispersant neat to very thick patches of oil around a fresh spill. This dispatch and the ability to treat thick patches of oil give the response effort enormous efficiency. The major drawbacks to spraying with marine craft is their relatively slow speed and constant need for direction from spotter aircraft. Therefore, an aerial spraying capacity was developed to augment the marine capability.

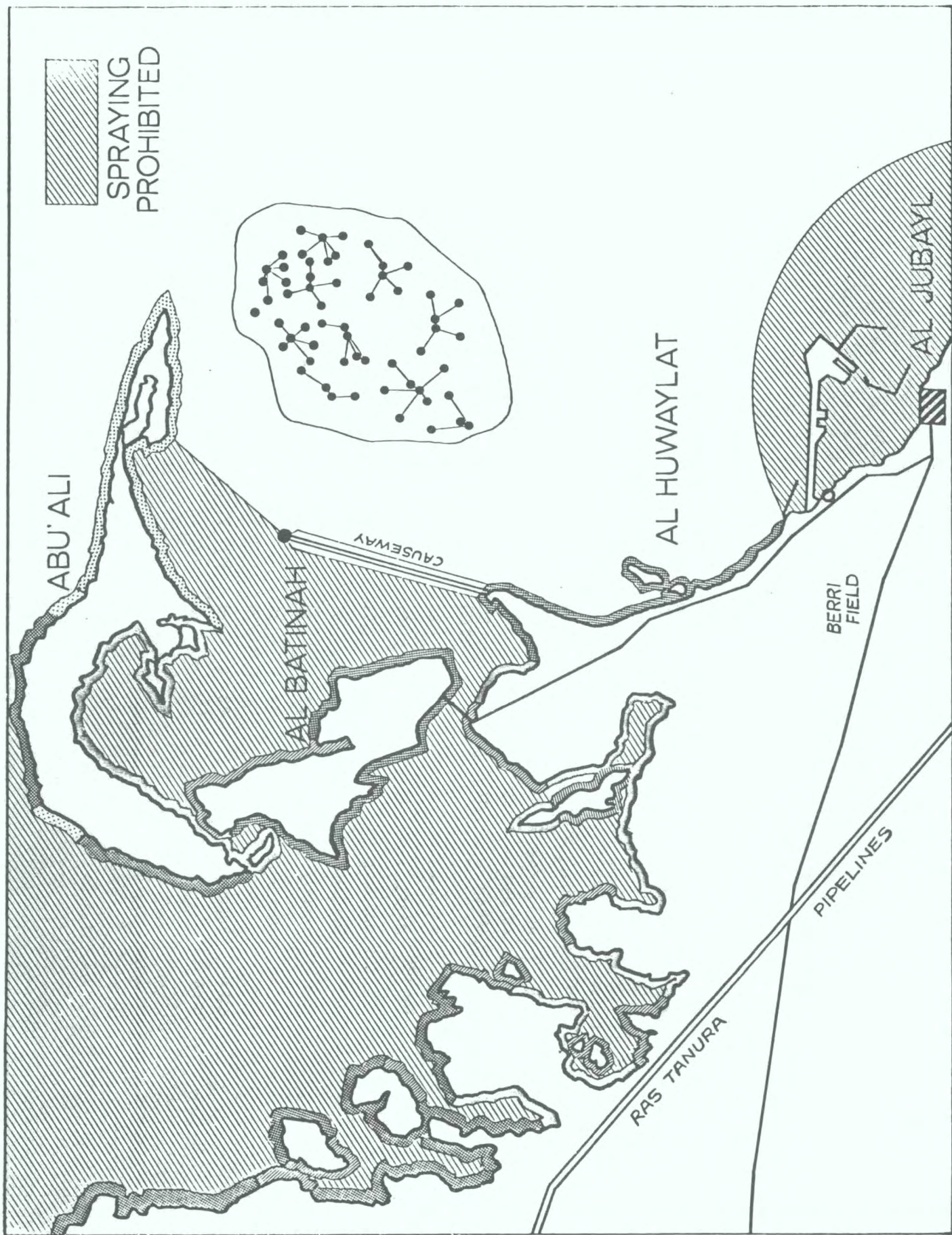

Figure XIII

TABLE I  
DISPERSANT APPLICATION VESSEL

LOCATION	NAME	SPEED KNOT	TK CAP. MGAL	BOOM FT	FLOW RATE GPM/%	DIMENSION L X W	DRAFT FT
JUAY-	RIMTHAN 1	7	0.5	60	30/10	160X35	15
MAH	RIMTHAN 2	7	1.2	60	30/10	243X59	17
	AL MUHTAR	7	1.2	60	30/10	110X32	14
	ZULUF 8	15	0.3	*	25/10	86X20	9
	JANA 1	12	0.2	(FIRE NOZZLE)	40/10	72X22	11
RAS	MAAGLA 6	12	1.2	60	10X10	50X15	8
TANURA	MAAGLA 7	12	0.7	60	10X10	50X15	8
	MARJAN 2	12	20.0	60	40X10	131X36	18
	MARJAN 4	10	20.0	60	40X10	131X36	18
	TARUT 2	25	0.2	30	10X10	23X6	3
	JARADAH 1	43	0.1	15	10X10	18X7	0.5
SAFA- NIYA	ZULUF 4	15	0.3	60	25/10	86X20	9

Table 1



RIMTHAN 2

BOOM 60 FT. + BEAM 59 FT. → SWATH 119 FT.  
 DISPERSANT FLOW RATE → 3 GPM  
 DISPERSANT TANK CAPACITY → 1200 GALLONS  
 MAXIMUM SPRAYING TIME → 6.6 HOURS

DOSE GALLONS PER ACRE	VESSEL SPEED KNOTS	AREA COVERED PER HOUR (ACRES)	MAXIMUM AREA COVERED WITH FULL TANK ACRES
5	2.2	36	240
7	1.6	26	171
10	1.1	18	120

MARJAN 2

BOOM 60 FT BEAM 36 FT. → SWATH 96 FT.  
 DISPERSANT FLOW RATE → 4 GPM  
 DISPERSANT TANK CAPACITY → 20,000 G  
 MAXIMUM SPRAYING TIME → 83 HOURS

DOSE GALLONS PER ACRE	VESSEL SPEED KNOTS	AREA COVERED PER HOUR (ACRES)	MAXIMUM AREA COVERED WITH FULL TANK ACRES
5	3.6	48	4000
7	2.5	34	2860
10	1.8	24	2000

Table 2.

There are 13 helicopters now owned or under lease to ARAMCO including nine Bell model 206B and four model 212. The former is a small helicopter with a 1,320-pound (600 kg) capacity and the latter is a larger helicopter with a 4,200-pound (1,910 kg) capacity. The aircraft are normally used to change crews and inspect and maintain operations on offshore facilities. Dispersant spray buckets are on hand to use with the helicopters in the event of any oil spill.

ARAMCO currently owns four simplex spray buckets, three 300-gallon capacity buckets and one 150-gallon bucket. Because of their small payload, the Bell 206B helicopters have not been used to apply dispersant. They are used as spotter aircraft for the Bell 212 as well as the boats. The 206s can also be used to transfer empty buckets from one location to another.

The spray buckets now in use are slung from the bottom of the Bell 212 by a wire rope and are somewhat clumsy to use. The long distance between the bucket and the helicopter prevents the pilot from seeing the bucket and its height above water. Therefore, he must be guided by a spotter helicopter and a crewman at the door of the aircraft. Even with these limitations the helicopter spray operation is quite effective. Helicopters can be mobilized and on the scene very quickly. They can move rapidly from one patch of oil to another; and, at just 50 to 100 feet of water, the pilots can see more clearly where to spray.

ARAMCO is reviewing new, more efficient spray gear for the helicopters. The new gear can be placed in the 212s rather than slung underneath and will hold 400 gallons instead of 300 gallons. This new equipment will reduce the ground operations and require fewer ground crew. It will also give the pilot better control, since there will be nothing hanging below the craft that he cannot see. It is felt that up to 600 gallons of dispersant could be applied during a 10-hour spraying day using helicopters. At present, only two of our marine vessels hold in excess of 1,500 gallons and it is unlikely that any vessel will be able to efficiently apply more than 6,000 gallons a day. Thus, the helicopters will continue to play a significant role due to their manoeuvrability, speed and flexibility to operate from such locations near the spill as offshore platforms.

One point which should be brought up at this juncture is the cost of helicopters as compared with boats. Most of the technical literature on the subject suggests that helicopters are not very cost-effective. In ARAMCO's case this is not true. During a spill ARAMCO does not charter all the spill control equipment, either marine or aircraft from outside sources. Equipment that is already owned or chartered for other purposes is generally used in the spill response. Thus, a spill response merely diverts the equipment from one use to another. Charges for the equipment use are determined just as they would have been for the original use. A boat costs so much per operating hour, whether it is used as a tug or spill response boat. The same conditions apply to the use of aircraft. Therefore, during a 12-hour operating day, a work boat would cost 12 times the hourly rate or in some cases a flat day rate. The helicopters, however, are charged on an hourly flight time basis. During a 10-hour workday a helicopter might be in the air only five or six hours and apply the same amount of chemical as an efficient vessel during a 12-hour day. The costs have been found to be quite competitive. This would not, however, be the case if the helicopter had to be specially chartered or if different accounting and leasing methods were used.

Dispersants are not the answer to every oil spill and ARAMCO has also considered containment and recovery. Effective recovery operations require not only a large amount of equipment and trained manpower, but also good weather and small areas of oil. When the oil is spread out on a front 20 kilometres long and the boom is only sweeping a path of 200 metres at one kilometre an hour, the limitations of

recovery become apparent. However, when there is a thick patch of oil in a windrow, or oil coming from a single source such as a broken pipeline or a holed tanker, a well-mounted recovery operation can be quite effective. ARAMCO has kept open the recovery option for such cases. At present, ARAMCO owns about two thousand metres of boom which is suitable for use in seas up to about one metre. Along with the boom are a variety of skimming devices, pumps and other hardware necessary to carry out a moderate recovery operation. The scale of the recovery is currently limited by storage capacity. ARAMCO has only one slops barge, 4,300 barrels capacity, in which to collect recovered oil. This limitation can be overcome by chartering additional equipment, but this requires a few days' lead time at the minimum.

Since the use of booms and skimmers requires a fairly high degree of expertise in this specialized field, ARAMCO planning had included contractor assistance in the use of such devices. The Oil Spill Response Manual lists specialist oil spill clean-up contractors in both the US and Europe who could be on the scene within 24 hours of a call. In the event of a spill where the recovery option would be effective, ARAMCO would call on these contractors. The booms, skimmers and auxiliary equipment would be prepared for use during the contractor's transit time from his home base. While this method is not quite as fast as having on-site personnel, the actual difference in response time is only a few hours, a delay that is more than offset by the increased efficiency of the subsequent operation.

Response actions using booms include protection in addition to recovery. As mentioned earlier, there are certain high vulnerability areas offshore. Booms can be used to protect these areas by preventing oil from entering intakes or shallow bays. In these circumstances the booms act as a back-up for the major spill response which may be a combination of dispersant application and recovery. This back-up is critical, since even the best pollution-combating effort may be over-taxed by the size of the spill, adverse weather, equipment failure or a number of other factors. The use of booms as a second line of defence offers added security to specially vulnerable localities.

The third key to a response programme is training. ARAMCO trains the entire range of personnel likely to be involved in an oil spill, from executive managers to marine foremen and skippers who operate the equipment. At the management level, training includes short courses designed by specialists to give the overall picture of oil spill planning and response. These courses help management make decisions on capital equipment expenditures to prepare for a spill, on operational techniques and resources needed to combat a spill and on decision-making processes which must be implemented in the event of a spill. While executive management is not generally directly involved in the day-to-day clean-up operation, it has been found that the advanced preparation given to management enables a spill response to be carried out more effectively. The management courses help to eliminate the need for detailed explanations during a time of crisis.

At the mid-management or supervisory level, training has become more specific. Again the short course approach has been taken, but in this case the courses are designed to cover actual equipment use and techniques. There are at least a dozen supervisory personnel who have participated in spill response programmes ranging from 40 to 80 class hours. This programme is ongoing with one or two individuals attending courses each year.

At the operating level, training is accomplished while on the job. A spill control unit in the Marine Department is used as a training group for the entire department. A core of permanent staff is kept in the unit and trainees from other units are cycled through the spill control course to give them practical experience. Training includes deployment of booms, maintenance of equipment, application of

dispersants and familiarization with marine operations in the event of a spill. The personnel in this unit are also given a five-hour course in spill control that has been prepared on video tape. This course is both in Arabic and English and was adapted from a course professionally prepared in the United States for oil company personnel.

The last item mentioned in the overall programme in spill contingency planning and response was the development of the Gulf Area Oil Companies Mutual Aid Organization (GAOCMAO). ARAMCO has been with the organization since its conception. During this workshop you have heard about the history and future development of GAOCMAO. ARAMCO feels that this organization can provide all the oil companies in the Gulf with an expanded capability to handle oil spills. However, as with any organization, there must be a continuing reassessment of strategy and purpose. The operating environment has changed considerably since GAOCMAO was formed; the oil production of the Region has increased, the Governments have become more active in the field of environmental protection, and experience has been gained by the companies. In order to be an effective organization, GAOCMAO needs to change with the times. To this end ARAMCO has supported changes which will make the organization more responsive to the needs of its members.

In the final analysis, it must be asked: How successful have ARAMCO's programmes been and what is planned for the future?

The answers are mixed. On the whole, when one considers the scope of our operations, we have been fairly successful in preventing large-scale spills. In the past five years ARAMCO has produced in the order of 15 thousand million barrels of oil and during this time there have been only three offshore spills in excess of 1,000 barrels. This rate compares very favourable with other areas in which oil is handled in quantity. Yet there is still room for improvement. Three spills of this size are still three too many.

The response to the spills that have occurred has compared favourably with the response in other areas of the world but further improvement is possible. For this reason ARAMCO has planned a major expansion of its response capabilities during 1981. Major capital outlays are to be made for new equipment to increase the capability to implement a response which will handle large spills over a wider area. This response will include enhanced recovery and modernized dispersant systems. In addition, ARAMCO will be participating with the Saudi Arabian Government in the National Contingency Plan which is now being developed.

In summary, ARAMCO will continue to improve all aspects of oil spill prevention and response on a scale compatible with its world leadership position in oil production.

In the light of recent events which have affected us all, I was in two minds whether or not to deliver the address which I had completed prior to the Kuwait Action Plan Region being involved in its biggest oil pollution problem. Having read what I wrote at the time, I feel that the comments are justifiable and, for me at least, having now had the practical experience of being involved, these comments are more than interesting. With your permission therefore, I will present my previously prepared paper.

If I may, and in order to refresh your memories, I feel it would be worth while to briefly appraise you of the status of GAOCMAO. At the present moment, the organization has 18 member companies stretching from Iraq in the north, southwards along the Arabian side of the Region and then to the east to embrace the United Arab Emirates and Oman. Other companies within the area are anticipated to be joining the organization in the fullness of time as their operations permit eligibility for membership.

Geographically, the organization is divided into three parts, known respectively as the 'Northern', 'Central' and 'Southern' areas (see map).

It is regretted that companies operating in Iran, although having attended GAOCMAO meetings from inception in 1972, did not at the time nor until the present date, deem it necessary for reasons of their own, to join the organization. Certain criteria do, of course, pertain to membership of GAOCMAO and the basic consideration is one of a company handling oil through a refinery or tanker terminals which therefore puts a company 'at risk' of being a possible polluter of the environment. A membership fee is payable to the organization on joining and, thereafter, each member contributes financially to GAOCMAO on an annual basis, depending on oil production and export figures. Each member is also obliged to purchase and maintain equipment such as spray booms for example, and other associated clean-up or oil pollution prevention items, as well as a stockpile of dispersant. As the name of the organization implies, the 'Mutual Aid' concept was, and is, devised for assistance to be given to members as may be requested in the event of an oil spill that is considered to be beyond the capability of any single member to deal with.

The organization has what is termed an 'Operators' Committee' which comprises delegates from all member companies, who normally meet formally on an annual basis, or as often as may be decided necessary in the light of events. The 'Operators' Committee' in turn nominates, from its members, three persons to form an 'Executive Committee' who serve in office for one year. This 'Executive Committee' comprises a Chairman, and two Vice-Chairmen, each appointee representing one of the member companies in the respective geographical areas.

Since inception in 1972, GAOCMAO has operated successfully within the parameters conceived at that time to provide some methods of combating possible oil pollution within the Region. The basic joint capability to clear up oil spills which are beyond the capability of a single member, is still, some eight years later, considered to be an ideal principle which has been proved, albeit on a relative barrelage spill disaster basis, to be effective, and without question, necessary and worth while.

With the advent of VLCC and ULCC vessels and the ever-increasing risk potential occasioned world-wide by the expansion of offshore drilling and oil production complexes, the dangers of oil pollution have unfortunately been highlighted in numerous incidents to an energy-conscious world. These factors have not escaped the notice of Governments and other responsible bodies within (specifically) the Kuwait

Action Plan (KAP) Region, which is the topic of our concern, and which is recognized by the meeting of this distinguished assembly here in Bahrain at this time. That this area has not yet experienced a major oil spill problem is something for which we are not only thankful, but which also makes us conscious that it may only be a matter of time before we are faced with that emergency.

In the light of experience gained from information resulting from other disasters - and that is emphasized as the right word to use - the awareness of Governments of the Region in conjunction with international bodies, major oil companies and last but by no means least, GAOCMAO itself, has given rise to considerable serious thought and most welcome action in an attempt to be in a position of limited effectiveness, and have instant response to a mutual disaster.

As in so many things, time itself is probably the biggest drawback to the implementation of means to combat the problem. None of us as individuals nor as corporate bodies should be under any delusion as to the magnitude of the very real, minute by minute, day by day problems which are staring us directly in the face.

The time for action is now - before it is too late. "Very easy for you to say" is a comment heard quite frequently, "but how is the aim to be accomplished?". There are many factors which are currently recognized as possible 'problem areas' and which have to be resolved. These include, but are not necessarily limited to (1) international boundaries, (2) freedom of movement of personnel and equipment in the event of an emergency, (3) cost, (4) availability of trained people, and (5) communications.

As an organization, GAOCMAO has been aware of the above, and associated, problem areas for some time, and in honesty to you all, it must be said that no real solution has been achieved, and this fact to my mind, emphasizes the point made earlier about the seriousness of the problem. It is no use 'burying one's head in the sand' or paying 'lip service' to something which one obviously hopes in reality will never happen, but nevertheless, in recognition of the distinct possibility, or even probability, that it will, constructive action must be taken, and taken quickly. 'Yes', it will cost money; 'yes' it will occupy a large number of people on a full-time basis; 'yes', it may well cause inconvenience to individuals, but when done properly, the results will more than justify the means when an oil spill of any magnitude is successfully contained and eliminated.

It has been estimated that at this moment the collective response capability of GAOCMAO to deal with an oil pollution problem is in the region of a spillage amounting to 10,000 barrels. If one accepts that statement as fact - and there is little or no reason to suppose it is anything other than fact - it is painfully apparent that with all the goodwill in the world, a virtually impossible situation is on our doorstep. This meeting therefore is of paramount importance in not only assessing and identifying the problems, but in initiating and furthering positive and speedy action to control the situation.

At no time was it envisaged that any one member company, nor indeed the collective organization, would be either capable of, or responsible for, the protection or clean-up of the sea areas outside the operational or concessional areas in which its operations are centralized.

Herein, in essence, lies an area of great importance for clarification and understanding between individual members, GAOCMAO as a whole and the respective host Governments of the Region. In a realistic appraisal of the situation, GAOCMAO is aware that in the event of a major spillage, Governments may well anticipate, request or even require that the organization, or specifically a Member Company

could be given the task of ensuring that the spillage is contained or eradicated with a minimum of damage to the environment and property, or interruption to economic business. A company could even be held or deemed to be responsible for ensuring the above factors. This is unrealistic in practice and has to be recognized as such. It is perhaps relevant at this stage to mention that the member companies of GAOCMAO appoint personnel - such as myself for example - to be their representatives to the organization as part of the job responsibilities of the individual, within their own framework.

Following the increase of realization of vulnerability in the event of a disaster, and the considerable and welcome awareness of the Gulf Governments of the Region to the whole environmental and ecological situation, GAOCMAO is shortly to appoint a full-time Executive Secretary, directly employed by the organization. This person is expected to be based in Bahrain with effect from early 1981.

As has been stated by a previous Chairman of GAOCMAO, and I reiterate the comment at this time, whatever support GAOCMAO can give to any regional agreement, it will. Our aim is to work with and alongside Governments in the common interest of the overall preservation of the environment, with special reference to the combating and prevention of oil pollution.

We have already heard from eminent speakers about various aspects of oil pollution control, environmental considerations and practical operational problems which co-mingle to produce the intensity of awareness which responsible bodies accept as reality.

Our greatest problem is in the realistic co-ordination for the common good of the expertise available. GAOCMAO is obviously more than interested in remaining as a functional body and is dedicated to furthering its own efficiency and to co-operating wholeheartedly with other organizations and Governments in the area.

That gentlemen, as I said at the beginning of my presentation, was what I had written some weeks prior to the events which have recently taken place. I feel even more strongly now that a number of points mentioned bear a very great resemblance to what, regrettably, has been proved from experience. The majority of us here at this time have been involved in this recent incident, the full repercussions of which are still to be felt. I sincerely hope that the very real lessons will have been learnt and taken to heart.

To say that 'lightning never strikes in the same place twice' would be a doubly disastrous frame of mind to adopt. How much effort, time and money would have been saved had the correct action been taken years ago, and consolidated Contingency Plans been laid!

The logistical problems facing a plan of the magnitude that I believe is necessary, are enormous, but must be tackled quickly. Let us all learn from the experience we have recently undergone.

If we do not act, then we will only have ourselves to blame for whatever the future may hold in store.

I have recently re-read an article which specifically pointed out the inadequacies of the KAP Region to combat an oil spillage. A number of points raised are only too true. I have heard say, - and I can quite believe it, - that one of the major obstacles to the task confronting us, is that of the bureaucratic systems which surround us. The present organizations within the oil companies simply do not permit 'the system' to be broken. Normally, no action can be implemented on anything

unless the 'Authorized signatures' are shown, and then, - but only then, - will someone actually do something. Let us be realistic in saying that personalities within a group often affect the outcome of actions.

People have to jealously guard their own - to them - important 'Empires' and will stand on their own 'dignity' or assumed importance, whilst at the same time being totally unaware, - or even totally unconcerned, - of the facts necessitating action, - not, tomorrow, - but NOW. Call it 'human nature' if you wish, - call it whatever else may be apt, - but never forget or underestimate the stark reality of it all. It is not only the companies that suffer from the above problems, but government bodies as well.

As commented earlier, gentlemen, I repeat that it is absolutely no use burying one's head in the sand or paying 'lip service' to the problems.

We either mean to be effective or we don't, - that is the decision to be made first and foremost. Once established, then please let us carry it out in a determined and positive way. The warnings have been given, and the answers are now, at this moment, within our grasp.

I thank you, gentlemen, for asking me to participate in this meeting, and I trust that some of the points raised will be noted and acted upon to the best of our ability for the good of all.

Thank you.



POLICIES ON THE USE OF DISPERSANTS - THE ROLE OF TOXICITY TESTING

PROGRAMMES FOR OIL DISPERSANT CHEMICALS

by  
K. Wilson

North West Water Authority,  
Great Sankey, Warrington, U.K.

ABSTRACT

Oil dispersants can modify the chemical and physical characteristics of the marine environment directly and by their action upon oil to such an extent that the resources of that environment may be detrimentally affected. Marine fauna and flora are particularly at risk. Two methods have been developed for reducing the risk of environmental damage caused by the use of dispersants. The first method establishes the policy on where, when and how dispersants can be used and it operates through an analysis of the risks to resources from using dispersants compared to the risks resulting from leaving oil alone or using an alternative method of treatment. The second method establishes criteria for selecting and licensing those dispersants likely to have minimal environmental impact. Selection criteria include toxicity, effectiveness and chemical composition. The factors important to the implementation of these methods of control are discussed.

## INTRODUCTION

The stranding and destruction of the Torrey Canyon in the approaches to the English Channel in March 1967 was a significant event in the annals of marine pollution from several points of view but, in particular, it was the first time that specially formulated chemicals had been used on a very extensive scale as a method of treating crude oil at sea and on beaches. The purpose of the bulk of these chemicals was to break down the oil into droplets small enough to be dispersed by water currents and wave action, thereby avoiding contamination of beaches important for holiday-makers. Between mid-March and the end of April some 22,000 tonnes of dispersants (as the chemicals were called) comprising a wide variety of formulations were applied to many different types of oil and oil/water emulsions in a variety of environmental situations and using a variety of methods. Not surprisingly, with so many different circumstances involved, it was difficult to assess the overall success of the method in achieving its objective but it was clear from an early stage that the widespread use of dispersants had resulted in damage and death to plants and animals, particularly on the shore. The adverse publicity surrounding their use led to a generally held belief that the environmental effects of dispersants were worse than the effect of oil, and indeed this attitude undoubtedly led many national authorities to effectively ban the use of dispersants. However, there were circumstances where the use of dispersants caused no detectable environmental damage. Further it was found that some dispersants alone and with oil were much less damaging to the marine environment than others. On the other hand, dispersants did not always work effectively to disperse the oil or oil/water emulsions, though some dispersants were more effective than others.

Despite the difficulties that accompanied the use of dispersants during the Torrey Canyon incident, the UK Government still firmly believed that dispersants had an important role to play in its overall strategy for dealing with accidental oil spills at sea and it set out to optimize that role in the light of the experience gained. Two complementary methods commended themselves. The first, here called environmental control, was concerned with specifying the conditions of the environmental arena in which dispersants could be used to maximum effect, but with minimal or acceptable environmental impact. It was therefore concerned with defining where and when dispersants could or should be used, how they should be applied and in what quantities. The second method was concerned with identifying those dispersants which could be used in the environmental arena and it was therefore concerned with the characteristics of the dispersant - its chemical composition, safety, effectiveness and its toxicity to users and marine organisms - generally in relation to a number of pass-fail criteria. This latter method is here referred to as laboratory control since most of the evaluation of a dispersant was based on standardized laboratory tests.

This general approach of environmental control combined with laboratory control has now been adopted more widely in the world, though it has been continually updated in response to practical application and modified to take account of particular local circumstances.

## ENVIRONMENTAL CONTROL

The basis of environmental control stems from an understanding, derived empirically or experimentally, of the ways in which oil and oil/dispersant mixtures behave at sea or on beaches and how they may modify the resources or uses of those environments.

### Behaviour of oil and oil dispersants

Crude oil is a very complex mixture of hydrocarbons together with organic compounds of sulphur, nitrogen and oxygen. The hydrocarbons can be divided into three major groups based upon their chemical structure - the n-alkanes (paraffins), cycloalkanes (naphthenes) and aromatics, and it is the different proportions of these hydrocarbons and trace organics that characterize crude oils of different origins. Refined products also have characteristic compositions. When oil is spilled on to water it floats, but its behaviour is characterized in other ways too. The oil will spread laterally at a rate and to a thickness that is controlled by its viscosity, temperature etc.; certain fractions, particularly those with the lowest boiling points ("light") will evaporate at rates dependent on temperature, surface activity, wind speed etc.; some fractions will be removed by photo-oxidation or auto-oxidation; and some oil will enter the water column as droplets (dependent on surface activity) or in solution, different fractions having different water solubilities. The residue will tend to become more viscous and lead to a more persistent slick. It will also become heavier and eventually it may even sink to the bottom to re-appear as tar balls washed ashore. There is also a tendency for crude oils to form water-in-oil emulsions (known as 'mousse') and this can greatly increase the persistence of the slick.

Oil dispersants are basically composed of two chemical components, a surface active agent and a suitable carrying vehicle or solvent, though other additives may be present to improve the stability of the mixture, etc. The nature and amounts of the surfactant and carrier vary from product to product, and even from batch to batch within a product, but generally they can be classified on the basis of the type of solvent. Those based upon a hydrocarbon solvent are designed to be applied to the oil in undiluted form. Those based on alcohols or glycols as solvent were developed later than the hydrocarbon-based dispersants. They tend to have much higher concentrations of surfactant and many can be used neat or pre-diluted with water. All dispersants work in essentially the same way. The surface active agent aligns itself at the oil/water interface below the slick, thereby reducing the interfacial tension. The oil tends to take up the form of least surface energy, namely a droplet, and once the slick has been broken up in this way it is dispersible by wave action and diluted by diffusion and surface currents in the sea. The extent to which the action of the dispersant contributes to an increased dissolution of hydrocarbons from the oil or affects the rates of physical, chemical and biological degradation of the oil, is still largely a matter of conjecture.

### Environmental effects of oil and oil dispersants

Both in qualitative and quantitative terms, the environmental impact of oil and dispersant is related to a large number of factors, including the type and amount of oil spilled, its location, the time of spillage, sea conditions, and the type and amounts of dispersant used. For present purposes it is convenient to consider the effects, not in relation to these factors specifically, but in relation to the disposition of the oil or dispersant, namely on the surface of the sea, on the bottom of the sea, in the water column, and effectively out of the sea, on shores and beaches.

- (a) Oil on the surface. Oil on the sea has two visible well known effects: it can kill sea-birds, and it interferes with human activities. Many species of sea-bird spend considerable amounts of time swimming on, or feeding in, the surface waters of the world's oceans and the presence of oil there can greatly interfere with their normal behaviour. Oil

penetrates the plumage removing much of the waterproofing and insulating properties of the feathers and, although additional stress may be added through swallowing of oil during preening, oiled birds at sea usually die from drowning or exposure. For some species the risk is particularly significant because they feed, breed or moult in large congregations. Mammals, such as seals and whales, and turtles appear to be less at risk, but contaminated animals have been found.

There are, at least potentially, other biological effects. A layer of oil on the surface of the sea will, by preventing the penetration of light, cause a reduction in photosynthetic activity, the process by which phytoplankton produce the organic matter upon which life in the sea ultimately depends. This effect is unlikely ever to be very significant however. Similarly the reduction in gaseous exchange at the sea surface brought about by the layer of oil is unlikely to lead to oxygen levels low enough to affect plants or animals. Surface dwelling fish and zooplankton may well become entrapped in the surface layer but, except in very extreme cases, this will occur on too small a scale to affect local productivity.

Perhaps the most conspicuous interference with man's activities is the impact of surface oil on recreational pursuits such as sailing or swimming where, in addition to the visual degradation of the area, contamination of both craft and the human being can occur. Surface oil can also interfere with shipping and other boat traffic, by presenting a hazard of fire or explosion or by affecting navigable routes. It can contaminate fishing boats and fishing gear, tainting any catch of fish hauled through it. Fish pens and aquaculture units with surface structures are especially vulnerable. Industrial plants using sea-water for process or cooling purposes can be rendered inoperative by the threat or presence of surface oil.

- (b) Oil on the sea bed. The impact of oil that sinks to the bottom as a result of degradative processes rather than being sunk deliberately tends to be much less dramatic, not only because it is out of sight but because it is generally present in small lumps rather than a continuous sheet. Rarely, the tarry residues may be eaten by animals; more frequently they will be caught in fishing gear where they may taint the catch. The oily residues tend to be mobile and may gather in quiet areas, as a hazard to fishing or mining, or they may eventually come ashore to affect the amenity value of beach or shore.
- (c) Oil in the water column. Oily waters may constitute a threat to domestic or industrial water supplies but generally the most significant impact is a biological one. Oil that enters the water column either in solution or as droplets is more readily available to a very wide range of plants and animals, either living freely in the water or attached to or submerged in the bottom sediments, and therefore the oil is potentially capable of exerting effects over a very wide spectrum. The effects are proportional to the concentration of oil so that the risks of damage are higher in shallower areas since less water is available for dilution there. When present in high concentrations oil droplets can cause clogging of gills and other respiratory surfaces, and many organisms have been observed to ingest droplets of oil, apparently without harm. The soluble fractions are potentially more harmful. Laboratory experiments with water-soluble fractions of oil have demonstrated detrimental effects on the productivity of plants, impaired fertilization of gametes, abnormal development of

larvae, behavioural abnormalities in fish and shellfish, lowered survival and modified respiration, growth, feeding and fecundity in a wide range of organisms from simple protozoans to fish. The extent and significance of some of these effects in natural situations is difficult to assess but mortalities of fish and shellfish are clearly of economic as well as ecological significance. Soluble components can affect fish and fisheries at levels much lower than those necessary to kill fish. Fish can detect some hydrocarbons by smell and this can cause them to avoid contaminated areas and possible capture. Other compounds can impart obnoxious tastes and smells to fish flesh making it unacceptable for human consumption, while still other compounds, such as polynuclear aromatic hydrocarbons, can be accumulated in fish tissues where, being carcinogenic, they represent a health hazard to human consumers.

- (d) Oil on beaches. This is the form of oil pollution that is most familiar to the general public and the one that affects them most directly. Although seldom a risk to public health, oily residues can contaminate skin and clothing, and generally lead to a reduction in the amenity value of an area. This can often result in severe consequences for those employed in the tourist and holiday industries, as well as for those employed in other activities based on the shore. Fishing interests are particularly susceptible to damage. The biological effects of stranded oil can be severe. Salt marshes and mangrove communities are susceptible to the smothering and toxic effects of oil, and rocky shore animals may be similarly tainted or killed by the temporary blanket of oil. Oil may penetrate into soft sediments of mud or sand, affecting the organisms buried there. Birds may be affected directly by being fouled with oil or by losing important feeding areas.
- (e) Effects of oil dispersants. The important consequences of adding dispersants to the environment are three-fold. Firstly the dispersants can exert their own toxic effect on plants and animals in the water or on the shore; secondly, they may modify the form and availability of the oil to exert its effects; and thirdly, they may interact with the oil to produce more, or less, harmful effects. Generally dispersants increase the amount of oil in the water column, either as emulsion or solution, and therefore they increase the risk of effects from this type of pollution. When used on shore, dispersants can reduce the viscosity of stranded oil so taking it into contact with animals deep in burrows or crevices that would otherwise have avoided contact with the oil. Concentrated emulsions or solutions of oil and dispersant may run off beaches into shallow water and there affect sub-littoral organisms. Dispersants can lead to the deeper penetration of oil in soft sediments such as sand and mud, where it may produce greater biological damage or prolong the period over which the amenities of the beach are affected.

#### Towards guidelines for controlling the areas of use of dispersants

The major objective in using dispersants is to achieve the most efficient removal of oil from the surface of the sea, or from intertidal areas, consistent with cost and minimal environmental damage. The decision as to whether or not to use dispersants in any particular situation will depend to a large extent on the alternative methods for dealing with the oil that are available, but it is possible to prescribe certain conditions where dispersants are more or less an appropriate method of treatment. For example, whilst dispersants are capable of tackling most liquid oils and liquid oil/water emulsions, their effectiveness decreases with increasing viscosity of the oil or emulsion. Therefore even the most effective

dispersants are, at best, of only limited use against mousse, heavy fuel oils, or crude oils that have undergone "weathering". At worst they are completely ineffective and, apart from being a waste of valuable material and money, their use constitutes an unnecessary additional pollution. In the same way the use of dispersants against light refined oils spilled at sea is probably unnecessary, since this type of oil dissipates naturally in a very short time.

The primary area for use of dispersants then is in situations where natural dispersal of freshly spilled crude oil is likely to be low (i.e. in relatively sheltered areas), where alternative methods are unsuitable (on practical, economic or environmental grounds) and where some resource is threatened by undispersed oil. The policy on the use or non-use of dispersants therefore is based on the protection of resources and, where there is a conflict of interests of different resources, on their relative priorities. As described earlier, the way in which dispersants modify the effects of oil on a given resource depends on where the oil is located. Thus, dispersants will tend to reduce or eliminate those effects associated with oil at the water surface but will tend to exacerbate those associated with oil in the water column or on the shore. In simple terms, the implementation of the policy on dispersant use involves establishing the balance between the risks to resources from oil on the water surface and the risks to the same or other resources within the water column.

The balance of risks from the two types of pollution can change along the continuum from open sea to shore. A spillage of crude oil a long way offshore is likely to degrade or dissipate under natural agencies when the major problem is likely to be the re-appearance of oil as tar balls at points widely dispersed in space and time from the original spillage. Dispersant treatment is therefore not generally useful in these conditions except where it may be deployed to protect a specific offshore resource such as a sea-bird colony. Under these conditions, the dilution available for both oil and dispersant will be sufficiently high to avoid significant ecological damage. In coastal waters there may be the very real risk that the oil slick may be blown ashore to threaten resources on the beach, interfere with coastal navigation and fishing or affect birds and mammals, and this may be sufficiently serious to invoke the use of dispersants at a time when depth of water and water movements still provide sufficiently high dilution to protect fish and other biota in the water column. With an oil slick even closer inshore the chances of it reaching the shore are even greater and it is in the generally shallow coastal strip that resources such as fishing, aquaculture, recreational sailing, swimming and industrial uses of water tend to be concentrated. It is also the zone where fisheries and marine biota are most at risk from oil and dispersants in solution since the dilution available is correspondingly less than offshore. The narrow coastal zone can therefore be regarded as being the most critical and it is in this area that contingency plans have made use of the concept of "particularly sensitive areas". As the name implies, the purpose is to identify those areas which have a particularly high resource or user value so that a specific policy of treatment, appropriate to each area or type of area, can be determined in an unhurried atmosphere prior to any spillages of oil. Important criteria in identifying particularly sensitive areas include number of uses, uniqueness of uses, economic importance, scientific or ecological importance.

The concept can be extended to the littoral zone, but dispersants, even when used carefully and judiciously, generally increase the risk of environmental damage to the beach or to the sublittoral area to such an extent that their use is not recommended except for exceptional circumstances. In other words, beaches generally should be regarded as particularly sensitive areas as far as dispersants are concerned, and alternative methods for treatment of oil stranded on the shore should be given a higher priority.

## LABORATORY CONTROL

The quantitative expression, that is the intensity, of the effects of oil is related to the quantity of oil spilled and its composition. Similarly the intensity of effects produced by a dispersant is related in part to its composition and to the quantity required to render the oil dispersible, but also to the interactive effects it produces with oil. In any situation where the use of dispersants is contemplated, it appears sensible to use a dispersant which is not only most effective but which produces the minimal impact itself and when combined with the oil. What is required, therefore, is a method for identifying dispersants with the above characteristics, and a procedure for encouraging or permitting their use only. One method of assessment that can be used in a predictive mode for quantifying the potential impact of dispersants on marine plants and animals is the toxicity test.

What is toxicity and how is it measured?

Toxicity is the innate ability of any substance to cause harm to living organisms and it is important to realise that virtually all substances can be toxic to life at some level. The type of harm (effect) that is produced by a substance depends largely on its specific chemical properties but is also a function of the concentration of the substance and the exposure, that is, the length of time the biological system is exposed to it. It is common therefore to see toxicity categorized in terms of these three variables, namely concentration, time and effect. Thus a highly toxic substance is one which produces an effect at low concentrations whilst a substance of low toxicity produces the effect only at a much higher concentration. Acute toxicity describes the harmful properties of a substance which are demonstrated within a short period, usually within a few days, of exposure, and it is typically related to the breakdown of physiological systems at rates which exceed the animals' ability to adapt to, or to repair, damage. In chronic toxicity the effects are seen only in the longer term, usually weeks, though it may more typically be a considerable proportion of the life span of the organism affected. Effects occurring at some intervening exposure period are described as the result of sub-acute, or more rarely sub-chronic, toxicity. The separation into one or other category is largely arbitrary but this is not so for categories based on effect, lethal - causing death, sub-lethal, less than or not resulting in death. These terms are often used to qualify one another. Thus an acutely lethal concentration of a substance is one which causes death in an organism in a short period, and in the same way it is possible to have acutely sub-lethal, chronic lethal, and so on.

Generally, for most substances, there is a direct quantitative relationship between concentration and the effect measured, though the precise nature of this relationship will depend upon the identity of both. However, irrespective of the effect considered, the basic form of the concentration - response relationship is remarkably consistent and it is virtually no different if the degree of response in an individual or the proportion of the population responding is recorded. Examples of concentration response curves are shown in figure I. It can be seen that for each type of effect there is a threshold concentration below which the effect cannot be measured. Above the threshold there is an increase in response with increasing concentration until the maximum response for that effect is obtained. Concomitant with the concept of threshold concentration is a no-effect level; the lower the concentration for a no-effect level the more sensitive is the effect. A no-effect level is not the same as a non-toxic or safe level, for, by utilizing increasingly sophisticated techniques, it is usually possible to detect effects at lower and lower concentrations, even if it is not always apparent how significant these effects are.

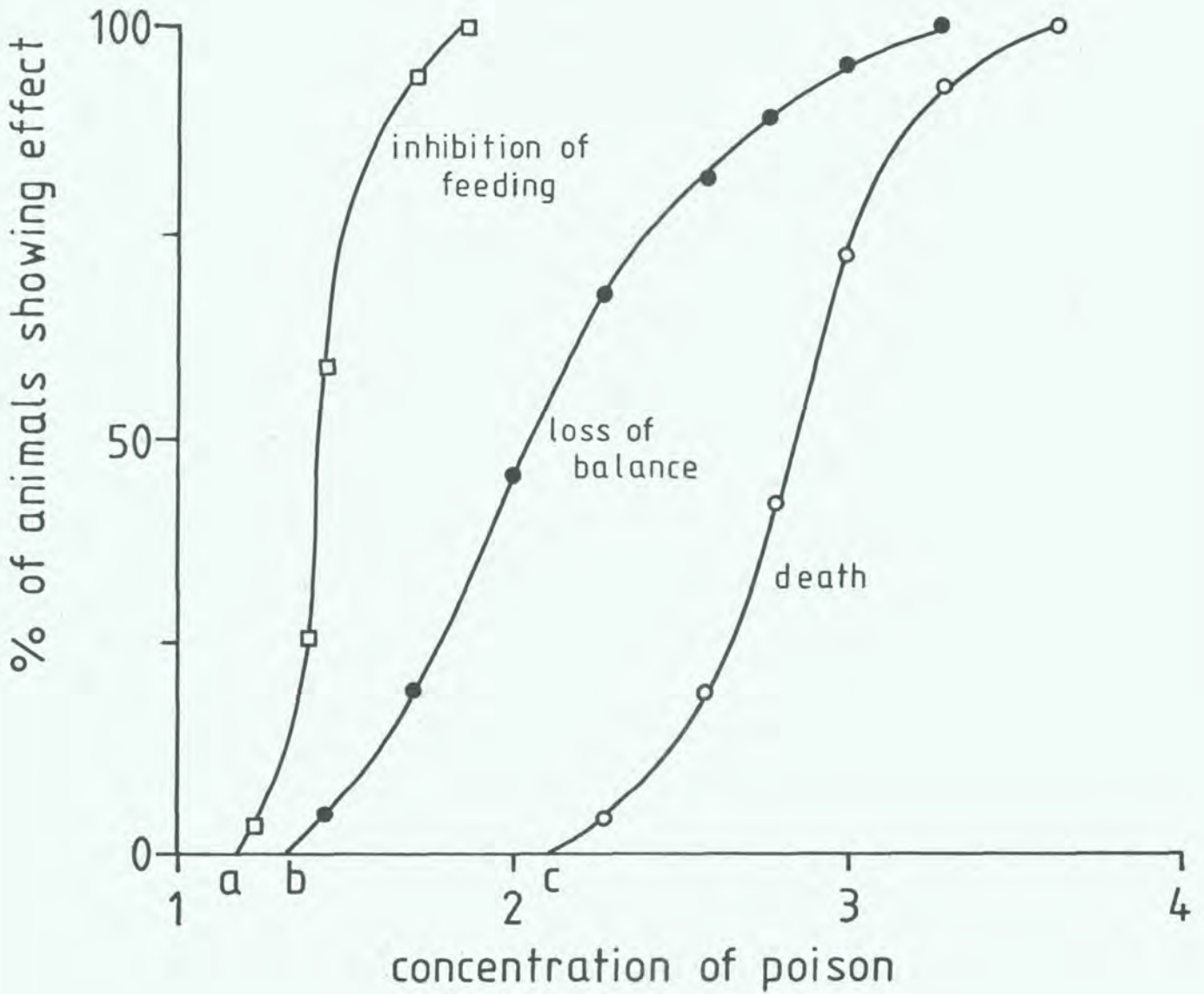

Fig. I Examples of Concentration - Response curves for three different effects observed in fish exposed to solution a, b and c are the threshold concentrations for inhibition of feeding, loss of balance and death respectively. Death is the least sensitive of the effects shown.



A toxicity test is the use of living material to define the relationship between concentration and effect. The usual method of toxicity testing in the aquatic environment is to subject a sample of a species of test organism to a range of concentrations of the substance and to observe the effects of the substance with time. In most cases only a single effect is recorded and this is defined before the test begins, for example, death, loss of balance. Basically there are two procedures for the collection and treatment of data from such a test. In the first the length of time of exposure required to produce the observed effect is recorded for each individual in each concentration, and the time taken to affect a given proportion of the animals (usually 50 per cent) is calculated for each concentration. One technique is to plot the data graphically, expressing percentage mortality as probits against time on a logarithmic scale. The basic statistics of the line can then be obtained directly. These statistics are the geometric mean (the time at 50 per cent effect, ET50) and variance (which can be derived from the slope of the line). Considerably more accuracy is obtained by measuring the average rather than the minimum or maximum response, since estimates of the latter are so dependent on the numbers of animals in the test. The slope of the line is important because it gives an indication of the variability of the test animals, the smaller the slope the more variable the population.

In the second procedure, the number of animals affected in the different concentrations is recorded at fixed time intervals after the beginning of the exposure period, and the concentration affecting a given percentage (say 50 per cent) of the test population at those times is interpolated from the data. Typical time/effect and concentration/effect curves are shown in figure II.

When the calculated effect times are plotted against their respective concentrations, a toxicity curve is established; in the same way the calculated median effect concentrations can be plotted against time to produce a similar curve (figure III). It is customary in graphical representations to use logarithmically transformed data for the toxicity curve. This has two advantages. Firstly, it enables wide limits of time and concentration to be covered and secondly, it is possible to detect readily whether or not a curve, which with arithmetic axes appeared to have become asymptotic with the time or concentration axes, really has done so. These asymptotes can be taken to indicate the minimum median effect concentration and the minimum response time respectively.

In summary, it is possible to describe the toxicity of a substance in a number of ways but, for all of them, the value of toxicity will depend upon the type of test organism used, the size, sex and condition of the organisms, the effect measured, and water quality aspects such as salinity, temperature and pH. Toxicity can be described by:

- (a) The shape and position of the toxicity curve. Curves displaced increasingly to the left signify increasing toxicity.
- (b) The length of exposure required to affect (kill) a given proportion of the test animals at a fixed concentration (i.e., for example, 1000 ppm ET50). The smaller the value of the ET50 the more toxic is the substance.
- (c) The concentration required to affect (kill) a given proportion of the test animals after a fixed length of exposure to the substance (e.g. median lethal concentration at 48 hours, the 48h LC50). The smaller the value of the LC50 the more toxic is the substance.

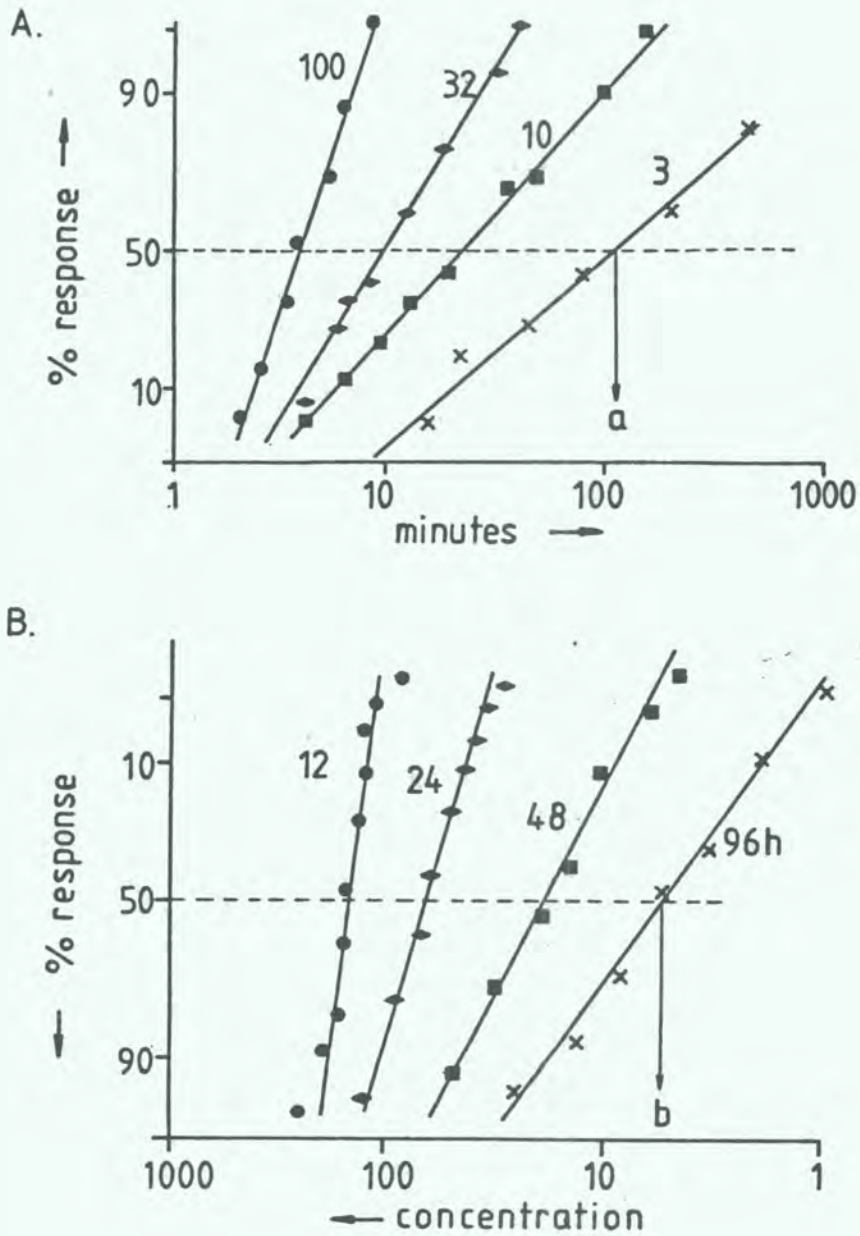

Fig. II Examples of (A) Time - Percent effect curves and (B) Concentration-Percent effect curves. The intercept of line 'a' with the time axis give the median effect time (ET50) for 3mg/l. The intercept of line 'b' with the concentration axis gives the median effect concentration (EC50) at 96 hours (96h EC50)

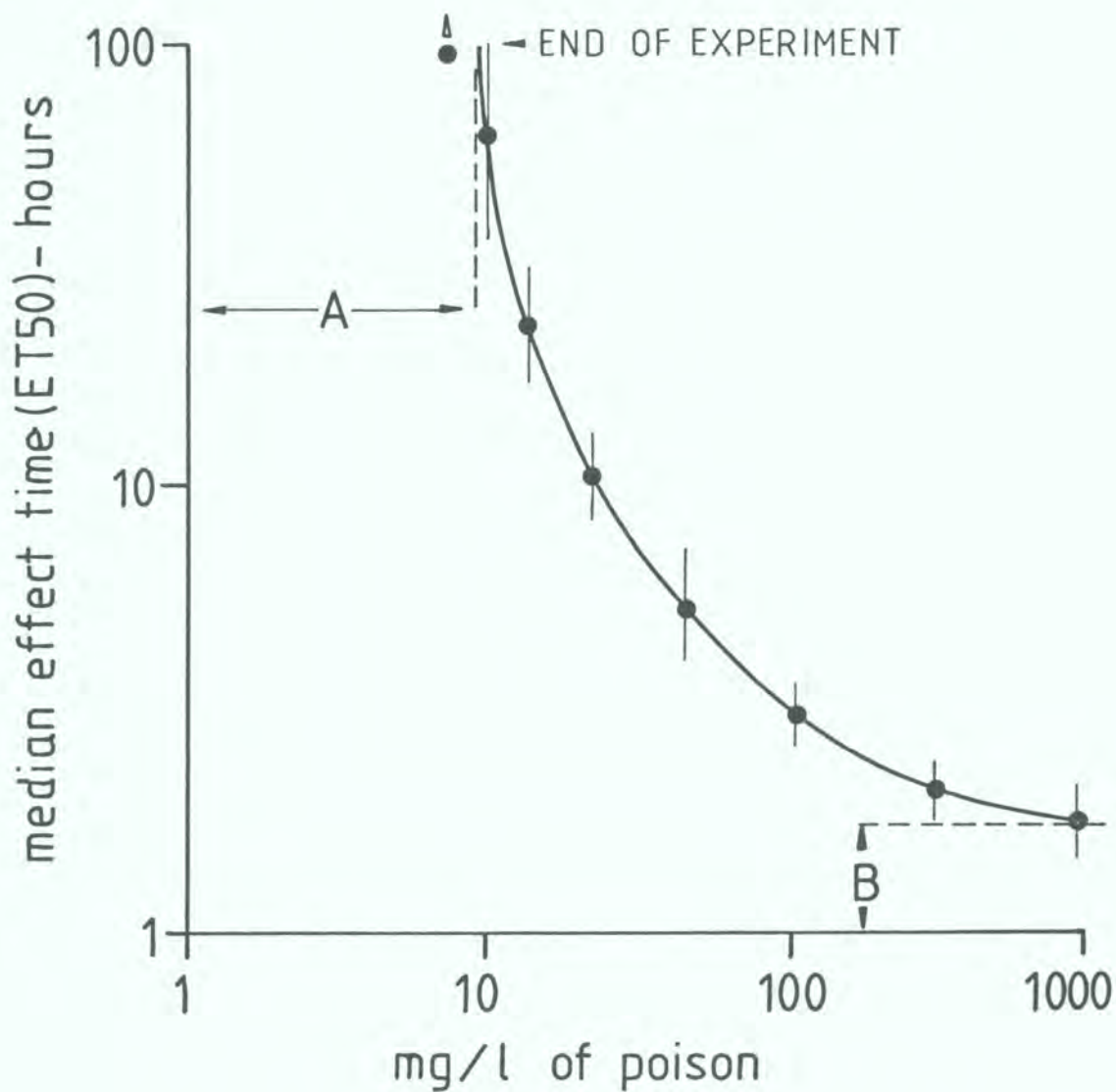

Fig. III An example of a Toxicity Curve with ET50 values (and estimated variance) plotted against their respective concentrations. A is the asymptotic median effect concentration, B is the minimum response time. An essentially similar curve is obtained by plotting EC50 values against their respective exposure times.

- (d) The proportion of the test animals affected (killed) in a given concentration after a fixed exposure period. The greater the proportion of animals affected the more toxic the substance.

#### Toxicity tests with oils and dispersants

Toxicity tests with oils and dispersants have been carried out on three scales.

1. The controlled application of oil and dispersant in experimental field situations has proved a useful validation technique because the conditions of exposure most closely resemble those likely to pertain in real situations. Data collected in these experiments are therefore of high ecological significance. However, they are usually difficult and expensive to carry out and of relatively long-term duration so that only few oils or dispersants can be examined in this way.

2. Experiments carried out in large aquaria, either in the field or laboratory, or in field enclosures, offer the advantages of greater control of experimental conditions whilst still maintaining a high degree of ecological relevance. But again the experiments tend to be relatively long-term and expensive.

3. Laboratory-based experiments in small aquaria, on the other hand, can be made very cheaply; they can be of short duration so that a large number of variables can be investigated; and they allow great control of experimental conditions. It is this type of test that has increased our understanding of how oils and oil dispersants cause biological damage.

Many of the short-term studies on the toxicity of oil, particularly those of earlier workers, report the results of toxicity in terms of the amount of oil actually added to the test aquaria (the nominal concentration) and the results in this form show that different oils appear to have very different acute toxicities, ranging from about 10 mg/l (4 day LC50) for refined oils, to greater than 10,000 mg/l for weathered crudes. It was further found that the toxicity of oil was influenced by the method of testing, particularly the amount of mixing and surface agitation that was applied. However, when these data were expressed in terms of the amounts of hydrocarbon in solution (water-soluble fraction) a much more consistent pattern emerged, with the differences in toxicity being accounted for almost entirely by the different effectiveness with which the test methods introduced the hydrocarbons into solution. And the same was found to hold more or less true when examining the data for different oils. The differences in toxicity of the different oils and types of oil were greatly reduced when expressed in terms of water-soluble fraction, with 4 day LC50 values falling in the range ca. 1-20 mg/l for fish and 0.5-10 mg/l for other organisms. In fact, it is possible to explain even the relatively small differences in the toxicities of different crude oils in terms of the specific hydrocarbon composition of the water-soluble fraction. In broad terms, toxicity increases along the series alkanes - cycloalkanes - alkenes - aromatics, and within each homologous series small molecules are more toxic than large ones. Thus, crude oils contributing a water-soluble fraction with a high aromatic content will be relatively highly toxic.

The high toxicity of the earlier conventional dispersants was due to their hydrocarbon solvent and, to a large extent, to the aromatic concentration of the solvent. Acute toxicities in the range 0.1-10 mg/l were common, but later dispersants with low aromatic solvents or water-based had much lower toxicities, often greater than 10,000 mg/l nominal concentration. On the basis of nominal concentrations, then, these dispersants have a toxicity similar to or even less than the toxicity of most crude oils. It is much more difficult to generalize about the toxicity of oil/dispersant mixtures. The toxicity of the mixture is seldom less

than that of the oil but the extent to which oil toxicity is enhanced appears to be related in some way to the effectiveness of the dispersant in the test conditions, since increased toxicity of mixtures can be largely (though not entirely) explained by the increased solubilization of the oil by the dispersant.

Acute toxicity tests have also been useful in describing those biological factors such as type of organism and developmental stage, that are important in setting the level of toxicity of oils and dispersants, and whilst these tests may be criticized for their lack of ecological relevance, they have undoubtedly proved most useful in identifying conditions of potential importance in the realm of environmental control. Their greatest use, however, has been as a laboratory-based control. By standardizing important variables pertaining to the test, it is possible to use the toxicity data to rank the different dispersants, effectively in order of their potential hazard when used at sea. Two aspects need to be considered: - establishing appropriate standardized procedures for the test, and defining a method of comparing the toxicities of different dispersants.

Some degree of standardization is necessary to ensure that there is reproducibility between tests and therefore, that all dispersants are treated equally and fairly. It is not possible to cover comprehensively all those aspects which should be controlled in order to standardize test conditions; the following are of the highest priority.

- (a) Test species. The selection of an appropriate test species is likely to be a compromise of a number of factors. Thus, species that are locally of high ecological significance, economic significance or special sensitivity will increase the relevance of the test, but they may not be of a suitable size, may be difficult or expensive to obtain, or only available for a limited period of the year. The ability of the species to withstand laboratory conditions is also a major practical consideration.
- (b) Criterion of effect. To some extent the effect will be determined by the species selected, its size etc., but sensitivity to oil/dispersant and ecological relevance are important, though generally contradictory, aspects. Sensitive effects will be elicited by lower, and therefore more realistic concentrations, but they are nearly always sub-lethal and their significance in the real world is difficult to assess. On the other hand, significant effects such as death are relatively insensitive. Other aspects include the ease with which the effect can be measured, the time taken for it to be manifested, its reproducibility and cost. In most tests the chosen criterion of effect is death of the test organism.
- (c) Water quality. This will be suitable for keeping the test organisms alive but in addition it should be controlled with respect to salinity, pH and temperature. These should be selected to be representative of local conditions.
- (d) Exposure conditions. These are the most critical variables affecting the value of toxicity and the reproducibility of a test. The test aquaria may be built to take account of the test species, its size, and the number of organisms being tested, though conversely the type of aquaria that are available may dictate the choice of species. Methods for maintaining a constant concentration of dissolved or dispersed oil in the test solutions are relatively complex and expensive, as are methods which aim to simulate natural or near natural dilutions of oil or oil/dispersant mixtures with time. In static tests, that is with no continuous change of test solution, the degree of agitation that is provided is important. Earlier

dispersants formed more or less stable emulsions at their toxic levels, so agitation of the water surface was not necessary. Later dispersants, however, tended to settle at the surface, and agitation of the water was required to a greater or lesser extent to produce more homogeneous test solutions. This becomes very important when oil is included in the assessment of toxicity, since the method and degree of agitation markedly affect the extent to which a dispersant will increase the solubilization of oil. This may not be the same for different dispersants. The type of oil, the ratio of dispersant to oil and the method of mixing all affect the level of toxicity. The concentrations used and the periods of exposure may be predetermined by the selection of species, effects and other considerations, but where there is flexibility these should be matched to likely environmental conditions.

Having established a standard procedure it is necessary to decide on a method for comparing the toxicity data for two or more dispersants with a view to identifying the least (or most) toxic, or establishing their relative toxicities. In practice, the "end-point" of the experiment will be pre-determined during the formulation of the test and it will be instrumental in crystallizing conditions of the test. Usual end-points are the median lethal asymptotic concentration, 48h LC50, and percentage response after relatively short exposures to high concentrations, for example 100 minutes at 1,000 mg/l.

#### Towards an approval procedure

In many countries a governmental approval procedure has been set up in order to exercise some control over the dispersants which can be used at sea or on beaches but, although the apparent objectives for the control are the same, in most cases the types of procedures and the role of toxicity tests in them differ very markedly. However, it is possible to recognize two basic approaches. In the first type the dispersant is considered in respect of one or more of a number of characteristics: physical properties; chemical composition; safety; availability; shelf-life; effectiveness; toxicity; cost; and evaluated against a pass or fail standard for each in turn (table 1).

The "acceptability" of toxicity can be determined in a number of ways, by comparison with other dispersants or with oil, and the comparison can be made on the basis of any of the measures of toxicity described earlier (see figure IV). The selection of an appropriate standard is more difficult. One possibility is that the toxicity of oil and dispersant mixture should not be significantly greater than the toxicity of the oil alone. A second way is to establish a standard at a point that will only allow a given proportion or number of the least toxic dispersants to be accepted, whilst another way is to set a standard based on intuitive feelings or empirical information about likely field conditions. The overall value of data from a toxicity test can be improved if the conditions of the test have been adjusted to suit the type of procedure. Thus, where there is no independent assessment of efficiency or effectiveness, conditions of the test should aim to more closely simulate the conditions of oil dispersal likely to pertain at sea, and this can be done by adjusting the type and volume of oil, the method of adding dispersant and the degree of agitation. On the other hand, where there is an assessment of effectiveness, the toxicity test should attempt to eliminate this aspect by, for example, ensuring homogeneity of the test solutions. This dichotomous type of procedure results in a number of dispersants which pass, and therefore receive equal evaluation. The decision whether or not to use a particular dispersant is then likely to rely on considerations such as cost and availability (table 1).

(a) Dichotomous. A standard for pass<sup>(P)</sup>/fail<sup>(F)</sup> is set up for each criterion considered.

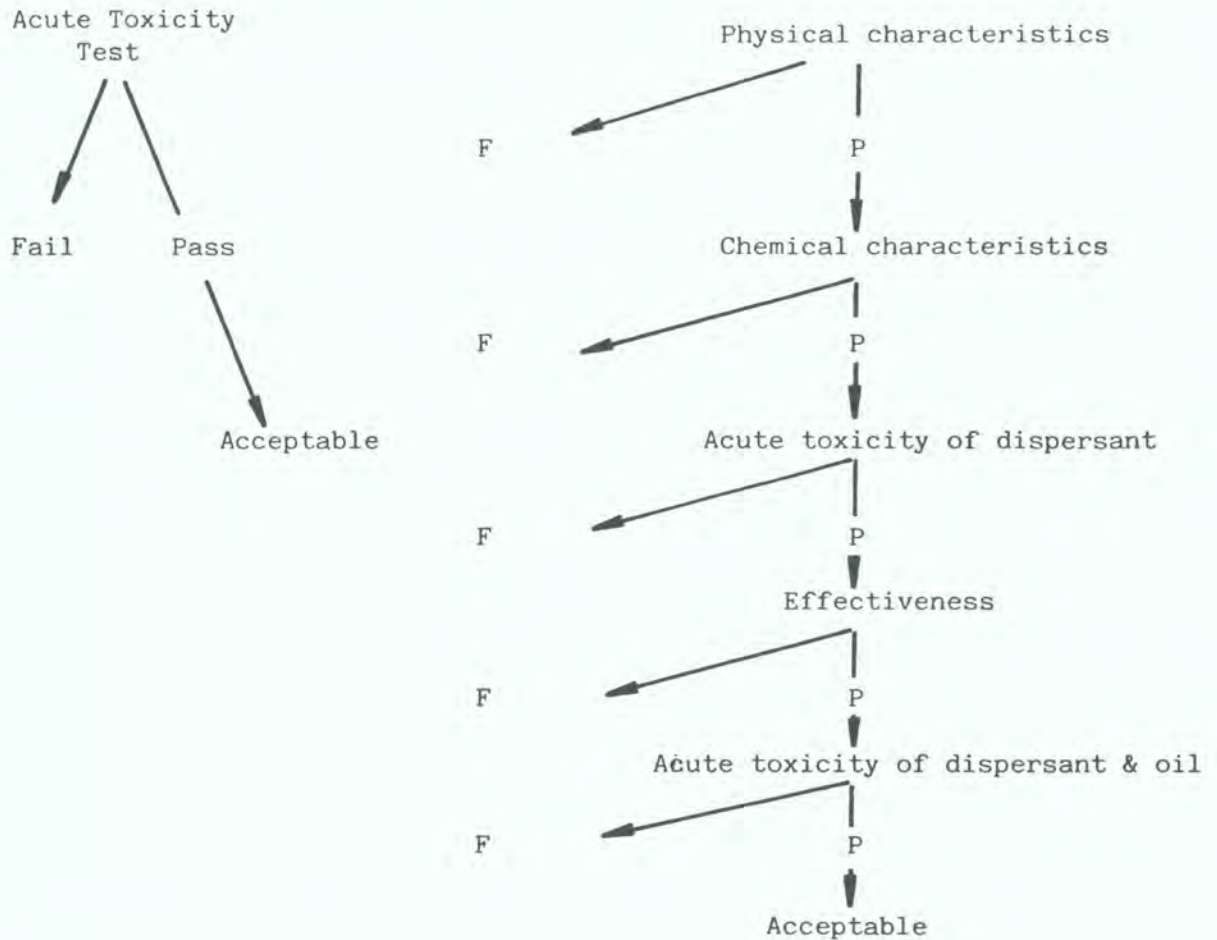

(b) Factorial. Acute toxicity, effectiveness, cost.

example: Dispersant	A	B	C	D
(a) Acute toxicity e.g. 48h LC50 mg/l	100	500	500	100
(b) Effectiveness (as dose rate) l/ha	10	100	50	30
(c) Environmental impact ( $\propto a/b$ )	0.1	0.2	0.1	0.3
(d) Unit Cost units/l	4	4	1	1
(e) Financial outlay/ha ( $\propto bxd$ )	40	400	50	30

Table 1: Examples of evaluation procedures for approving oil dispersants

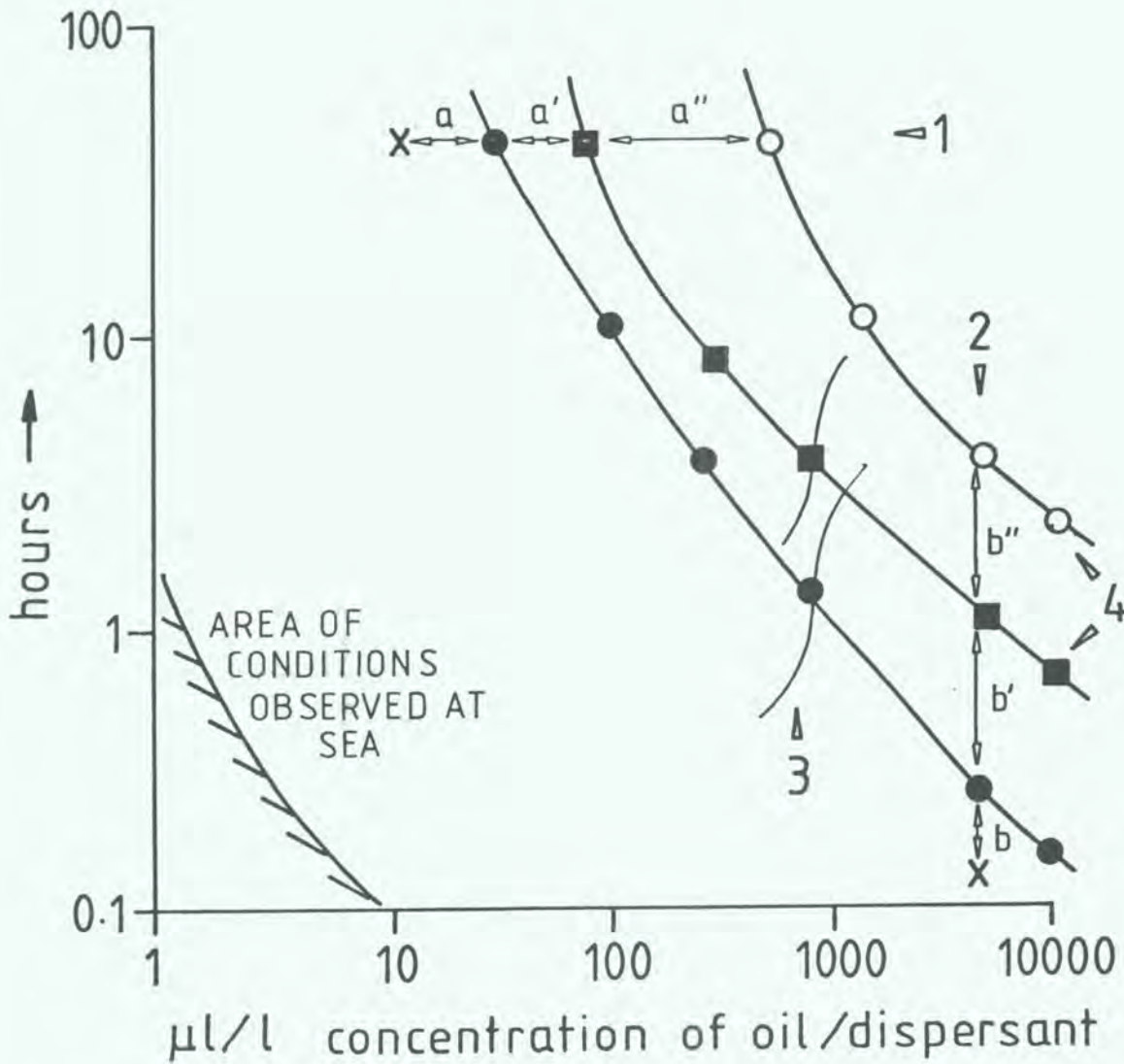

Fig. IV Examples of Toxicity Curves for dispersants and/or oil and dispersants showing different measures of toxicity and some methods for comparing toxicities.

1. For a fixed exposure period, comparison between EC50 values ( $a^I$ ,  $a^{II}$ ) or with a fixed standard EC50 ( $a$ ).
2. For a fixed exposure concentration, comparison between ET50 values ( $b^I$ ,  $b^{II}$ ) or with a fixed standard ET50 ( $b$ ).
3. For a fixed exposure period and a fixed exposure concentration comparison between the percentages of animals affected in the two test solution, or comparison with a fixed 'acceptable' percentage.
4. Comparison between the shape and position of toxicity curves. This is a more subjective assessment.



The second type of approach may consider essentially the same characteristics but it does so in a different manner. The value of each characteristic is not compared with a standard but treated as a variable, and the variables are then evaluated factorially (table 1). For example, dispersant A, which is more effective than dispersant B and will therefore need a ten-fold lower dose rate to achieve the same dispersion of oil, is arithmetically five times more acutely toxic. However, in environmental terms, A should be considered less hazardous than B because it will enter the sea at only one tenth the concentration. Dispersant C has the same likely environmental impact as A but is cheaper, while dispersant D is even cheaper, though with greater potential environmental risk. The disadvantages with this approach lie in the precision that is required in assessing the values for toxicity and effectiveness and, more importantly, it pre-supposes that the recommended dose rate will not be exceeded in practical situations.

### CONCLUSIONS

Experience of the early use of oil dispersants showed that, while they could be effective in dispersing certain types of crude oil, their use in clean-up operations, particularly on soft and rocky shores, led to damage to the biota. The adverse effects were due to a combination of circumstances - the use of dispersants in inappropriate locations, the use of highly toxic and ineffective dispersants, poor application technology and inexperienced users. Over the past 15 years considerable advances have been made to improve these aspects. Methods of application of dispersants, by knapsack, boat and aircraft, have all markedly improved and improved technology has also led to dispersants with much greater effectiveness and reduced toxicity, so that it can be fairly claimed that dispersants have now proved themselves to be a useful, and sometimes the only, effective tool against oil spills.

However, it is important not to become complacent. Modern dispersants should not be regarded as the panacea for all oil spills in all circumstances. It is necessary to identify the role of dispersants in the context of alternative methods of treatment and to clearly establish the conditions where they can and cannot be used. A policy of environmental control has been used with conspicuous success by some countries and the principles involved are likely to be generally applicable, but they need to be applied anew in each region. In particular, it should not be assumed that the behaviour and effects of oil and dispersants and the relative sensitivity of different resources as determined for temperate waters are necessarily applicable to tropical or sub-tropical waters.

It must also be pointed out that there are still dispersants being manufactured and sold which do not possess generally high standards of effectiveness and toxicity, so it is still important for some form of laboratory control to be carried out so that only satisfactory dispersants are approved for use. Acute toxicity tests carried out under standard conditions are an important tool for screening dispersants for biological activity, but their value is increased if they are used in conjunction with other tests, particularly those for physical and chemical composition and effectiveness. Conditions of the tests should be modified to the type of evaluation procedure and to suit local circumstances, but they should be of a form that is consistent with tests used in other countries so that a wider data base and wealth of comparable experience can be built up. Acute toxicity tests also have a valuable role for examining the effects of environmental variables on the behaviour and toxicity of oil and dispersants in order to provide feedback to the conditions specified by environmental control.

ANNEX

Information about the authors

K. Al-Qatari

Khalid Al-Qatari received his Bachelor of Science degree in Chemical Engineering from the University of Petroleum and Minerals in 1979. Upon graduation he began work in the Technical Affairs Department of the Ministry of Petroleum and Mineral Resources.

W.K.M. Astley

Capt. Astley is a Master Mariner with 14 years of sea-going experience on tankers with a major British oil company, and has since then served exclusively in the Kuwait Action Plan Region for a further period of 16 years in all aspects of offshore and terminal operations.

He has represented his company at local and international meetings on marine matters, and is the incumbent (1980-1981) Chairman of the Gulf Area Oil Companies Mutual Aid Organization (GAOCMAO), with which he has been associated since 1973. Capt. Astley is currently 'Head of Marine' of Abu Dhabi Marine Operating Company, based in Abu Dhabi.

A. Baxter

Mr. Baxter, ONC/HNC Mechanical Engineer, is Senior Construction Engineer of the Bahrain Petroleum Company. He served his apprenticeship with British Petroleum Company followed by three years' practical training at various BP refineries. After two years' Design Staff training at BP Grangemouth Refinery and BP Finnart Ocean Terminal he worked for seven years as Design Draughtsman/Surveyor on BP Refineries and Ocean Terminals. In 1966 he joined BAPCO in Bahrain where he spent eight years in the Refinery Engineering Section and six in the Construction Department. He assumed his present position of Senior Construction Engineer - Marine and Terminal Areas - in 1977.

D.J.S. Brown

Mr. Brown has had over 20 years' experience in the oil industry. He has been in Bahrain at BAPCO since 1981 where he served in the Inspection Department and the Engineering Department and assumed the post of Environmental Conservation Engineer in 1970. He was the first chairman of the Gulf Area Oil Companies Mutual Aid Organization (GAOCMAO) and was appointed chief engineer of BANOCO from 1976 to 1978 where he established the Engineering Department and managed the Service Stations Construction Programme. He has currently been appointed chairman of the Oil Spills Clean-Up Technical Sub-Committee .

Mr. Brown is a Chartered Engineer (C. Eng.) with a B.Sc. Hons. degree in Mechanical Engineering from Imperial College, London. He is a member of the Institution of Mechanical Engineers.

E. Brus

Mr. Brus is a Senior Researcher of World Information Systems and has collaborated with Mr. Golob on numerous pollution-related technical reports and data bases. He is a graduate of Williams College in Williamstown, Massachusetts, with a degree in geology.

#### J.E. Cuddeback

John Cuddeback received his B.S. and Ph.D. in Chemistry from the University of Texas at Austin. He spent six years teaching and carrying out research in analytical methods and industrial health at the University of Cincinnati where he was an Assistant Professor of Environmental Health. In 1975 he joined ARAMCO in Saudi Arabia, where he has been involved with environmental programmes in both the medical and engineering fields. He is now the Chief Environmental Affairs Engineer of ARAMCO with overall responsibility for co-ordinating environmental policy. He is a Certified Industrial Hygienist and has published a number of scientific papers.

#### J. Deck III

Mr. Deck has spent 20 years in the service of the United States Coast Guard, the latter half of which was with the Office of Marine Safety, Technical Division. Since retiring from active service in 1979, Mr. Deck has operated as a private consultant in marine safety and pollution prevention.

Mr. Deck is a graduate of the U.S. Coast Guard Academy and has advanced degrees in Naval Architecture, Marine Engineering and Mechanical Engineering from the Massachusetts Institute of Technology.

#### B. Dicks

Dr. Dicks is currently Director of the Oil Pollution Research Unit of the Field Studies Council, and has ten years' experience of oil pollution and research into its biological effects. Of those ten years, two and a half were spent as an environmental advisor to Shell UK Exploration and Production and the remainder on research into oil and dispersant toxicity, behavioural changes induced by oil and refinery effluents, the monitoring of refinery effluents, the biological impacts of offshore oilfields and environmental studies following oil spills.

Dr. Dicks is a marine zoologist with a B.Sc. from Reading University and a Ph.D. from Reading and St. Andrew's Universities.

#### R. Golob

Mr. Golob is Managing Director of World Information Systems and Executive Director of the Centre for Short-lived Phenomena and has specialized in data collection and information searches related to world-wide environmental management and pollution problems. In addition, he has advised government and industry on technology and contingency plans related to oil spills and other environmental emergencies. Mr. Golob is a graduate of Harvard University in Cambridge, Massachusetts, with a degree in biochemical sciences.

#### H. Hollins

Rear-Admiral Hollins joined the Royal Naval College, Dartmouth, in 1937 and went to sea in 1940. He retired from the Royal Navy early in 1977 and since then has been General Manager of the Middle East Navigation Aids Service.

E. Hull

Mr. Hull is currently involved in the training of personnel for offshore drilling and production activities.

Mr. Hull is a geologist with an M.A. degree from Oxford University. He has been associated with exploration and development drilling in Canada, Iraq, Papua, Iran, Alaska and the UK and has worked on development and safety aspects of North Sea Oil.

F. Krogh

Dr. Krogh is at present head of Veritas' Computer Simulation Center, and since 1976 has been involved in oil pollution activities, such as analysis of environmental data, development of computer programs for simulating the fate of oil in the sea, risk analysis, quality assurance, etc.

Dr. Krogh is a graduate in cybernetics from the University of Oslo.

O. Linden

Dr. Linden is a consultant to various United Nations agencies on environmental problems concerning oil and heavy metal pollution situations in tropical and sub-tropical countries.

Dr. Linden is a marine biologist and Head of the Marine Science Group at the Swedish Institute for Water and Air Pollution Research.

A. Nelson-Smith

Dr. Nelson-Smith is a Senior Lecturer at University College, Swansea, UK, where he teaches marine biology.

Dr. Nelson-Smith is a graduate biologist with B.Sc. and Ph.D. degrees. He has extensive experience in studying the ecology of estuaries, rocky shores and coral reefs and is a recognized authority on the effects of oil pollution.

J.A. Nichols

Mr. J.A. Nichols has worked in the Technical Department of the International Tanker Owners Pollution Federation (ITOPF) for six years and has attended a number of major oil spills throughout the world, rendering advice and assistance on clean-up methods. Currently, Mr. Nichols is Deputy Technical Manager of ITOPF and holds a B.Sc. degree in applied chemistry. He spent six years at the UK Government's Warren Spring Laboratory where he was closely associated with the development and approval testing of oil spill control chemicals and equipment.

J. Plenter

In 1974 Mr. Plenter joined the Smit International Group of Rotterdam and has since been involved in offshore installation and maintenance work, deep-sea towage and oil pollution combat. He is now manager of Smit Tak Anti Pollution Services (STAPS).

Mr. Plenter is a master mariner and has a M.A. degree in law from the University of Rotterdam.

#### J.Ph. Poley

Dr. Poley received his physics Masters Degree and his Ph.D. from Delft Technological University. He joined the Physics Laboratory of the Dutch National Defence Research Council in 1948 where he worked on microwave material properties and remote sensing techniques. Since 1957 he has worked for Shell, where he carried out research on non-conventional exploration and production methods, and was Head of the Department of Production Technology Research (including Environmental Conservation). Since 1977 he has been in charge of the department for Safety and Environmental Conservation of Shell's Exploration and Production Division in the Hague.

Dr. Poley is chairman of the oil industry E & P Forum's Committee on Environmental Quality, and represents the E & P Forum at meetings of IMO/MEPC, UNEP (Regional Seas Programme) etc.

#### A. Read

After a period in the clay industry following graduation, Mr. Read joined the Mineral Processing Division of Warren Spring Laboratory, UK, and ran a section there for eight years working on the development of separation processes for fine mineral mixtures and on various environmental problems associated with mining activities. Mr. Read has been with the Department of Energy since 1976 where he has been largely responsible for developing and implementing the environmental controls on the UK offshore oil activities.

Mr. Read is a chartered engineer holding B.Sc. and M. Phil. degrees.

#### P.B. Ryan

After 13 years in the chemical industry and one year teaching, Mr. Ryan joined ARAMCO as Marine Pollution Control Engineer and worked in this capacity for three years. Upon leaving ARAMCO in 1978, he operated as an independent consultant on environmental pollution problems, particularly marine pollution by oil. In March 1981 he was appointed Executive Secretary to the Gulf Area Oil Companies Mutual Aid Organization (GAOCMAO).

Mr. Ryan is an industrial chemist/oceanographer with a B.Sc. in chemistry and M.Sc. in oceanography.

#### I.C. White

Dr. I.C. White has over 10 years' experience in the oil pollution field, part of which was gained with the UK Ministry of Agriculture, Fisheries and Food, where he was in charge of research programmes on the biological effects of marine pollutants. Latterly, he has been with the International Tanker Owners Pollution Federation (ITOPF) and has been actively involved in the response to a large number of major oil spills world-wide on behalf of the Federation. Dr. White now holds the position of Assistant to the Managing Director. He is a marine biologist with B.Sc. and Ph.D. degrees from the University of London.

K. Wilson

Dr. Wilson has studied the effects of oils and oil dispersants on marine life since 1967. From 1970-1977 he worked for the UK Ministry of Agriculture, Fisheries and Food where he was responsible for developing the toxicity tests used to license oil dispersants in the UK. Dr. Wilson is now a Senior Scientist with the North-West Water Authority.

Dr. Wilson is a zoologist with B.Sc. and Ph.D. degrees from the University of Aberdeen.

J. Wonham

After working 10 years in the aero-engine industry, university research, lecturing and teaching and research with the British Gas Corporation, Wonham transferred to the position of Deputy Head of the Oil Pollution Division of the Warren Spring Laboratory. Since 1975, Dr. Wonham has been with the International Maritime Organization where he currently holds the position of Senior Deputy Director, Marine Environment Division.

Dr. Wonham is a chartered mechanical engineer with B.Sc. and Ph.D. degrees from the Universities of Wales and Glasgow respectively.

?

## PUBLICATIONS IN THE UNEP REGIONAL SEAS REPORTS AND STUDIES SERIES

- No. 1 UNEP: Achievements and planned development of UNEP's Regional Seas Programme and comparable programmes sponsored by other bodies. (1982)
- No. 2 UNIDO/UNEP: Survey of marine pollutants from industrial sources in the West and Central African region. (1982)
- No. 3 UNESCO/UNEP: River inputs to the West and Central African marine environment. (1982)
- No. 4 IMCO/UNEP: The status of oil pollution and oil pollution control in the West and Central African region. (1982)
- No. 5 IAEA/UNEP: Survey of tar, oil, chlorinated hydrocarbons and trace metal pollution in coastal waters of the Sultanate of Oman. (1982)
- No. 6 UN/UNESCO/UNEP: Marine and coastal area development in the East African region. (1982)
- No. 7 UNIDO/UNEP: Industrial sources of marine and coastal pollution in the East African region. (1982)
- No. 8 FAO/UNEP: Marine pollution in the East African region. (1982)
- No. 9 WHO/UNEP: Public health problems in the coastal zone of the East African region. (1982)
- No. 10 IMO/UNEP: Oil pollution control in the East African region. (1982)
- No. 11 IUCN/UNEP: Conservation of coastal and marine ecosystems and living resources of the East African region. (1982)
- No. 12 UNEP: Environmental problems of the East African region. (1982)
- No. 13 M. PATHMARAJAH: Pollution and the marine environment in the Indian Ocean. (1982)
- No. 14 UNEP/CEPAL: Development and environment in the Wider Caribbean region: A Synthesis. (1982)
- No. 15 UNEP: Guidelines and principles for the preparation and implementation of comprehensive action plans for the protection and development of marine and coastal areas of regional seas. (1982)
- No. 16 GESAMP: The health of the oceans. (1982)
- No. 17 UNEP: Regional Seas Programme: Legislative authority. (in preparation)
- No. 18 UNEP: Regional Seas Programme: Workplan. (1982)
- No. 19 UNEP: Regional Seas Programme: Compendium of projects. (1982)
- No. 20 CPPS/UNEP: Action Plan for the protection of the marine environment and coastal areas of the South-East Pacific. (1983)

- No. 21 CPPS/UNEP: Sources, levels and effects of marine pollution in the South-East Pacific. (1983) (In Spanish only)
- No. 22 UNEP: Regional Seas Programme in Latin America and Wider Caribbean. (1983)
- No. 23 FAO/UNESCO/IOC/WHO/WMO/IAEA/UNEP: Co-ordinated Mediterranean Pollution Monitoring and Research Programme (MED POL) - Phase I: Programme Description. (1983)
- No. 24 UNEP: Action Plan for the protection and development of the marine and coastal areas of the East Asian region. (1983)
- No. 25 UNEP: Marine pollution. (1983)
- No. 26 UNEP: Action Plan for the Caribbean environment programme. (1983)
- No. 27 UNEP: Action Plan for the protection and development of the marine environment and coastal areas of the West and Central African region. (1983)
- No. 28 UNEP: Long-term programme for pollution monitoring and research in the Mediterranean (MED POL) - Phase II. (1983)
- No. 29 SPC/SPEC/ESCAP: Action Plan for managing the natural resources and environment of the South Pacific region. (1983)
- No. 30 UNDIESA/UNEP: Ocean energy potential of the West and Central African region. (1983)
- No. 31 A. L. DAHL and I. L. BAUMGART: The state of the environment in the South Pacific. (1983)
- No. 32 UNEP/ECE/UNIDO/FAO/UNESCO/WHO/IAEA: Pollutants from land-based sources in the Mediterranean. (1984)
- No. 33 UNDIESA/UNEP: Onshore impact of offshore oil and natural gas development in the West and Central African region. (1984)
- No. 34 UNEP: Action Plan for the protection of the Mediterranean. (1984)
- No. 35 UNEP: Action Plan for the protection of the marine environment and the coastal areas of Bahrain, Iran, Iraq, Kuwait, Oman, Qatar, Saudi Arabia and the United Arab Emirates. (1983)
- No. 36 UNEP/CEPAL: The state of marine pollution in the Wider Caribbean region. (1984)
- No. 37 UNDIESA/UNEP: Environmental management problems in resource utilization and survey of resources in the West and Central African region. (1984)
- No. 38 FAO/UNEP: Legal aspects of protecting and managing the marine and coastal environment of the East African region. (1983)
- No. 39 IUCN/UNEP: Marine and coastal conservation in the East African region. (1984)
- No. 40 SPC/SPEC/ESCAP/UNEP: Radioactivity in the South Pacific. (1984)



- No. 41 UNEP: Socio-economic activities that may have an impact on the marine and coastal environment of the East African region. (1984)
- No. 42 GESAMP: Principles for developing coastal water quality criteria. (1984)
- No. 43 CPPS/UNEP: Contingency plan to combat oil pollution in the South-East Pacific in cases of emergency. (1984)
- No. 44 IMO/ROPME/UNEP: Combating oil pollution in the Kuwait Action Plan region. (1984)

Issued and printed by:



Regional Seas Programme Activity Centre  
United Nations Environment Programme

Additional copies of this and other publications issued by  
the Regional Seas Programme Activity Centre of UNEP can be  
obtained from:

Regional Seas Programme Activity Centre  
United Nations Environment Programme  
Palais des Nations  
GENEVA  
Switzerland

