



# MERS REGIONALES

PROGRAMME DES NATIONS UNIES POUR L'ENVIRONNEMENT

*L'impact potentiel des activités  
socio-économiques sur l'environne-  
ment marin et côtier de la région de  
l'Afrique de l'Est: Rapports nationaux*

*PNUE : rapports et études des mers régionales n° 51*

## PREFACE

Le programme des Nations Unies sur les Mers régionales a été mis sur pied par le PNUE en 1974. Depuis lors, le Conseil d'Administration du PNUE a constamment appuyé une approche régionale pour la lutte contre la pollution marine et pour la gestion des ressources marines et côtières; il a également réclamé la mise au point de plans d'action régionaux.

Le Programme des Mers régionales couvre désormais onze régions<sup>1/</sup>, et plus de 120 états côtiers y participent. C'est un programme qui met l'accent sur l'action et qui s'intéresse non seulement aux conséquences mais aussi aux causes de la dégradation de l'environnement; le Programme suit une approche d'ensemble qui, pour lutter contre les problèmes d'environnement, met l'accent sur la gestion des zones marines et côtières. Chaque plan d'action régional est formulé selon les besoins de la région tels que perçus par les gouvernements intéressés. Le plan d'action établit un lien entre d'une part l'évaluation de la qualité de l'environnement marin et les causes de sa dégradation, et d'autre part, les activités de gestion et de mise en valeur de l'environnement marin et côtier. Il pousse à la mise au point, de façon parallèle, d'accords juridiques régionaux et d'activités programmées qui mettent l'accent sur l'action.<sup>2/</sup>

Par décision 8/13 (C), le Conseil d'Administration du PNUE a demandé, lors de sa huitième session, que soit mis au point un plan d'action pour la protection et la mise en valeur du milieu marin et des zones côtières de la région de l'Afrique de l'Est. A titre de première activité entreprise dans la région, le PNUE a envoyé en octobre-novembre 1981 une mission exploratoire mixte PNUE/ONU/ONUDI/FAO/Unesco/OMS/OMI/UICN.

Les données et renseignements rassemblés par cette mission ont abouti à l'élaboration de six rapports sectoriels:

- ONU/Unesco/PNUE: mise en valeur du milieu marin et des zones côtières dans la région de l'Afrique de l'Est. Rapports et études des mers régionales No 6, PNUE, 1982.
- ONUDI/PNUE: Sources industrielles de pollution des mers et des côtes dans la région de l'Afrique de l'Est. Rapports et études des mers régionales No 7. PNUE, 1982.
- FAO/PNUE: La Pollution des mers dans la région de l'Afrique de l'Est. Rapports et études des mers régionales No 8. PNUE, 1982.
- OMS/PNUE: Problèmes de santé publique dans la zone côtière de la région de l'Afrique de l'Est. Rapports et études des mers régionales, No. 9. PNUE, 1982.

---

<sup>1/</sup> Région méditerranéenne, plans d'action sur la région du Kuwait, de l'Afrique de l'Ouest et du Centre, des Caraïbes, des mers d'Asie orientale, du Pacifique Sud-est, du Pacifique Sud, de la Mer Rouge et du Golfe d'Aden, de l'Afrique de l'Est, du Sud-ouest atlantique, et des mers de l'Asie du Sud.

<sup>2/</sup> PNUE: Réalisations et projets d'extension du programme du PNUE pour les mers régionales et des programmes comparables relevant d'autres organismes. Rapports et études des mers régionales No 1. PNUE, 1982.

- OMI/PNUE: Lutte contre la pollution par les hydrocarbures dans la région de l'Afrique de l'Est. Rapports et études des mers régionales No 10. PNUE, 1982.
- UICN/PNUE: Conservation des écosystèmes et des ressources des biologiques des mers et des côtes dans la région de l'Afrique de l'Est. Rapports et études des mers régionales No 11. PNUE, 1982.

Les six rapports sectoriels préparés sur la base des données rassemblées par cette mission ont été utilisés par le secrétariat du PNUE pour préparer un rapport de synthèse intitulé:

PNUE: Problèmes d'environnement qui se posent dans la région de l'Afrique de l'Est. Rapports et études des mers régionales No 12. PNUE, 1982.

Le rapport de synthèse et les six rapports sectoriels furent soumis à la réunion de travail PNUE sur la protection et la mise en valeur du milieu marin et des zones côtières de la région de l'Afrique de l'Est (Mahé, Seychelles, 27-30 septembre 1982) à laquelle ont assisté des experts désignés par les gouvernements de la région.

La réunion de travail a:

- passé en revue les problèmes environnementaux de la région;
- approuvé un projet de plan d'action pour la protection et la mise en valeur de l'environnement marin et côtier de la région de l'Afrique de l'Est;
- défini l'ordre de priorité des activités du programme qui doivent être menées dans le cadre du projet de plan d'action; et
- recommandé que le projet de plan d'action, ainsi qu'un projet de convention régionale pour la protection et la mise en valeur de l'environnement marin et côtier de la région de l'Afrique de l'Est, et de protocoles relatifs (a) à la coopération en matière de lutte contre la pollution en cas d'urgence, (b) aux zones spécialement protégées et aux espèces menacées, soient soumis à une Conférence de plénipotentiaires des gouvernements de la région, en vue de leur adoption.

En consultation avec les gouvernements de la région de l'Afrique de l'Est, l'élaboration du plan d'action a mis l'accent sur les activités directement reliées aux préparatifs de la Conférence des plénipotentiaires, et aux autres activités régionales que la réunion de travail de Mahé a recommandé de classer dans la catégorie de première priorité<sup>3/</sup>. Ceci inclut la préparation par des experts de la région, d'une série de rapports nationaux sur:

- les législations nationales;
- la conservation des ressources naturelles nationales: et
- les activités socio-économiques qui peuvent avoir un impact sur l'environnement marin et côtier.

---

<sup>3/</sup> Rapport de la Réunion de travail sur la protection et la mise en valeur du milieu marin et les zones côtières de la région de l'Afrique de l'Est, Mahé, 27-30 septembre 1982 (PNUE/WG.77/4)

Les rapports nationaux firent l'objet d'une synthèse dans des rapports régionaux 4/ 5/ 6/ préparés pour aider les gouvernements de la région de l'Afrique de l'Est à négocier la Convention régionale et ses protocoles. De plus, une réunion de travail sur la formation technique en matière de lutte contre la pollution par les navires pour la région de l'Afrique de l'Est a été organisée conjointement par l'Organisation Maritime internationale (OMI) et le PNUE, en novembre 1983.

Le présent volume est composé des rapports nationaux traitant des aspects juridiques régionaux sur la protection et la gestion de l'environnement marin et côtier de la région de l'Afrique de l'Est. Des ouvrages semblables, concernant la conservation et les activités socio-économiques dans la région de l'Afrique de l'Est, ont été recueillis 7/ 8/ 9/. Les huit études nationales ont été écrites par les experts suivants: C.L. d'Arifat (Maurice), B. Georges (Seychelles), M. Jardin (France), G.L. Kateka (Tanzanie), F. Muslim (Kenya), P.H. Randrianarijaona et E. Razafimbelo (Madagascar), A. Salim (Comores) et M.I. Singh (Somalie). Aucun expert n'a été désigné par le Mozambique, et de ce fait aucun rapport national n'est inclu dans ce volume. Les rapports nationaux sont reproduits dans la langue d'origine selon laquelle ils ont été préparés et soumis.

- 
- 4/ FAO/PNUE: Aspects juridiques de la protection et de la gestion du milieu marin et côtier de la région de l'Afrique de l'Est. Rapports et études des mers régionales No 38. PNUE, 1983.
  - 5/ UICN/PNUE: La conservation marine et côtière dans la région de l'Afrique de l'Est. Rapports et études des mers régionales No 39. PNUE, 1984.
  - 6/ PNUE: L'impact potentiel des activités socio-économiques sur l'environnement marin et côtier de la région de l'Afrique de l'Est. Rapports et études des mers régionales No 41. PNUE, 1984.
  - 7/ FAO/PNUE: Aspects juridiques de la protection et de la gestion du milieu marin et côtier de la région de l'Afrique de l'Est: Rapports nationaux. Rapports et études des mers régionales No 49. PNUE, 1984.
  - 8/ UICN/PNUE: Conservation marine et côtière dans la région de l'Afrique de l'Est: Rapports nationaux. Rapports et études des mers régionales No 50. PNUE, 1984.
  - 9/ PNUE: L'impact potentiel des activités socio-économiques sur l'environnement marin et côtier de la région de l'Afrique de l'Est: Rapports nationaux. Rapports et études des mers régionales No 51. PNUE, 1984.

TABLE DES MATIERES

	<u>Pages</u>
A.I. Bihi: Rapport national Somalien	1 - 17
M. Conan: Rapport national Français (La Réunion)	19 - 28
E. Faure: Rapport national Seychellois	29 - 58
M.H. Halindi: Rapport national Comorien	59 - 70
G. Kamukala: Rapport national Tanzanien	71 - 126
Mutua-Kihu: Rapport national Kényen	127 - 150
H.D. Rabesandratana: Rapport national Malgache	151 - 226
T.S. Ramyeed: Rapport national Mauricien	227 - 273

SOMALIA NATIONAL REPORT : by A.I. Bihi

BACKGROUND INFORMATION

The Somali Democratic Republic's 3,200 km coastline is virtually the longest coastline in developing Africa. The northern part of the coastline, latitude 11°N, is nearly 1,000 km long, while the eastern seaboard stretches from about 12°N to 2°S, a distance of some 2,000 km.

The northern coast of the Gulf of Aden consists of a series of sandy bays interrupted by rocky promontories extending into the sea down to a shallow depth. There are neither fringing coral reefs nor bars. From the coast, the sea bottom has a steep slope and the extent of the continental shelf is very limited. The 200 m contour line is, on the average, only 6 km from the shore except between Berbera and Zeila, where it is about 30 km wide owing to the presence of an offshore shoal.

The eastern coast from Cape Guardafui (Ras Asir) to latitude 8°N resembles the northern coast, except that sandy bays are scarcer and rocky outcrops more frequent. Along this part of the coast the continental shelf extends to about 50 km offshore. Between latitudes 6°N and 8°N the coast becomes sandy with a gradual appearance of coral. The shelf is 16 to 20 km wide and occasionally reaches 30 km. Some trawlable areas exist along this part of the coast. This is not true further south of the equator because of the more extensive coral reefs, deep ravines and the steep dropping off of the shelf. From the equator to 2°S lat., the shelf remains as narrow (about 16 km) and coralline as it is further north; there are about 500 islands parallel to the coast, more or less connected by reefs. This area is influenced by one permanent and one temporary water course and there are a number of trawlable areas, each of limited extent.

There are long and beautiful beaches along the coast, namely, Hobyo, Warshekh, Adale, Mogadishu, Jesira, Merca, Brava, Kismayu, Badada in the south of the country, and Zeila, Berbera, Mait and Laskoreh in the north. Among them, the most popular with local and international tourists are those at Mogadishu, Jesira, Merca, Brava, Kismayu, Zeila and Berbera. They consist of fine white sand and beach huts, restaurants, and other tourist facilities. Some of them are also used for artisanal fishing. The extent of beaches along the entire coastline could be estimated at 1,200 km.

The rest of the coastline includes steep rocky areas especially on the north-eastern stretch, starting from Eil and continuing through Iskushuban, Alula, Qandala, Bosaso and Laskoreh.

All along the Somali Coastline bordered by the Indian Ocean there are natural coral reefs that protect the beaches, particularly in the southern part of the country, at Jesira and Mogadishu, Adale, Brava and Warshekh for example. Mangroves are found in the extreme south of the country, i.e. in the Badada district and the Yamani channel, south of Kismayu, where they are cut down in moderation for local use in building.

The Somali coastline faces the open sea and does not include significant areas that lend themselves to the formation of lagoons except in the extreme south of the country, near the Bajuni Island of Jula and Jawaai, where the sea-shore is protected from the high tidal waves and ocean currents by the formation of extensive coral reefs and small islands. There are, however, no precise data available on the extent of such lagoon formations.

Somalia has two permanently flowing rivers, the Juba and the Shebelle, both rising in the Somali plateau in the territory of Ogaden, and which drain into a large catchment area after flowing for a considerable distance through vast territories of the southern regions of the country. Of the two main rivers only one of them, the Juba, flows into the Indian Ocean at a place called Gobwein, near Kismayu, in the extreme southern part of the country.

The outflow of the river Juba varies according to seasons. The river is sometimes shallow during the months of February and March and then is flooded during the rainy season of April-May, when it has an average flood flow of about 153 m<sup>3</sup>/second. Since it covers vast territories and its flood flow is high, its waters are always muddy when they flow into the Ocean during the rainy season.

The nearshore continental shelf is not extensive in Somalia, for the depth of the coastal zone waters increases suddenly, in most areas, at a distance of only a few hundred metres from the shore.

Present known land-based sources of pollution are as follows:

- (a) Marine pollution from municipal solid wastes is evident in Mogadishu, the capital. A municipal dumping site is situated right on the coast and the big tip is uncontrolled and possibly infested with vermin with the result that its marine pollution potential is high, especially in the rainy season when leachates run off directly into the sea. Similarly, municipal waste dumping sites are visible in other coastal cities like Merca, Kismayu, Berbera, Brava and Bosaso, where no other solid waste disposal systems are operative.
- (b) Livestock breeding of cattle, camels, sheep and goats is the main occupation of the Somali nomadic people. Pollution inputs thus largely consist of untreated effluents from slaughter houses, leather and affiliated industries. A specific example of discharge of untreated industrial effluent into the sea is the abattoir in Mogadishu, which slaughters about 50 camels, 200 cows and 250 goats and sheep daily and is located on the beach. The raw effluent containing blood is discharged into a pond which flows into another open ditch for biological treatment. The system allows an overflow of water, full of organic wastes, into the inshore waters. The polluting effect on the coastal waters and the beach is considerable, especially during the rainy seasons. This unhealthy incursion of the abattoir organic wastes into the open sea has from time to time attracted sharks into the lagoon waters and they have already killed some 10-15 people.
- (c) Marine pollution has also been noticed at the principal port areas at Mogadishu, Kismayu and Berbera due to waste disposal by ships and, since large numbers of livestock are exported through these ports, the fodder for these animals is added to the solid wastes that are sometimes washed into the sea by the rains, causing some pollution.
- (d) Another land-based source of pollution comes from the two or three fish-processing factories situated near the rich fishing areas on the north-east coast of the country, i.e. Bolimoog, Qandala and Laskoreh, all of which dump their industrial wastes into the sea.
- (e) In the south of the country there are extensive banana and sugar-cane plantations which use urea and other fertilizers. During the rainy seasons, these fertilizers are washed into the Juba river and ultimately into the sea.

The country has a subtropical climate with four seasons: Gu - the main rainy season, from March to May; Haqaa - from June to August, when the south-west monsoon brings some light showers to the southern coastal areas only; Deer - from September to November, the second rainy season, covering the whole country; and Jilaal - the dry season that dries up the rivers and sometimes causes droughts, from December to February. The temperature varies from 28°C to 32°C during the year.

The north-east Somali coast is characterized by an upwelling at the end of the south-west monsoon in October. This upwelling is responsible for very high, primary productivity since it brings up nutrient-rich waters from the deep ocean. The upwelling results in a great profusion of small pelagic species, mostly sardinelles. In order to exploit these conditions, major investments have been made to increase fishing activity along this coast.

The Somali coast is affected mainly by two current patterns - the Somali current and the Indian monsoon drift. The currents run parallel to the coast and though they are strong they are concentrated into narrow flows of up to 100 miles, beyond which the currents are often quite weak. To the north of 2°S the Somali current reverses in direction, following the monsoon winds. Generally this current flows north-east during the SW monsoon at a rate of 4 to 5 knots, occasionally reaching 7 knots during June to September. It flows SW during the NE monsoon at a rate of 3-4 knots.

The coastal population is generally estimated at one million and is directly or indirectly dependent on the coast and coastal waters because the country exports and imports all goods through its principal ports. About 100,000 people are directly engaged in artisanal fishing, extraction of building materials from coastal areas, and in tourism.

The coastal population has been increasing partly due to natural growth but also to migration and urbanization. The annual natural growth is estimated at 2.8 percent and the migration caused by the influx of refugees from Ogaden, urbanization and resettlement of the drought-affected populations in coastal areas accounts for an increase of about 7 per cent. This growth is particularly evident in Mogadishu, Berbera, Kismayu and Brava.

The principal economic activities of the Somali people are animal husbandry, agriculture, commerce, services, industries and fisheries. About 60 per cent of the population depends on animal husbandry, 20% on agriculture, 5% on commerce, 10% on services, 3% on industries and 2% on fisheries. It is also estimated that as many as 150,000 Somalis are working in the oil-producing countries of the Middle East.

There are no official statistics on gross domestic product (GDP), but according to estimates made in the Five Year Development Plan, 1982-1986, the gross national product (GNP) at 1978 market prices was 7,136.4 million Somali shillings (tables 1 and 2). The share of coastal activities is approximately 20 per cent of the gross national product.



The national infrastructure dealing with environmental issues consists of the following:

- National Commission for the Environment; operates under Ministry of Planning and Co-ordination;
- Ministry of Livestock, Forestry and Range;
- Ministry of Mining and Water Resources;
- Ministry of Fisheries;
- Ministry of Agriculture;
- Ministry of Marine Transport and Ports;
- Ministry of Tourism;
- Ministry of Health;
- National Range Agency;
- Regional and District Councils, operative in 16 Regions and 84 Districts.

The National Commission for the Environment is an advisory body and the Ministries are regulatory and control institutions. The national Commission for the Environment is composed of nominees from different Ministries and Agencies and has no financial resources of its own. However, substantial expenditure is incurred by the Ministry of Health and local Regional and District Councils for improving the quality of the environment, although no exact figures are available on the extent of this contribution nor on human resources.

#### URBAN AND RURAL DEVELOPMENT

The major coastal cities are Mogadishu, Kismayu, Berbera, Merca, Bosaso and Brava, but there are many small towns and villages along the coast: Zeila, Laskoreh, Mait, Alula, Hordiyoy, Bereda, Geesaley, Qandala, Hafoon, Eil, Hobyoy, Adale, Warshekh, Gandershi, Eil Ahmed and Kulmis, to name only the important ones.

The coastal cities of Mogadishu, Kismayu and Berbera maintain a sustained annual rate of expansion of 7 per cent due to urbanization and migration, while the population growth in the small north-east settlements is actually decreasing due to lack of communications and readily exploitable agricultural resources, such as rain-water (the annual rainfall is only 10 to 15 cm) and good soil. The people therefore migrate to the big coastal cities like Mogadishu which is expanding rapidly. Lack of suitable land and air communications in these north-eastern areas hinders the exploitation of the rich fishing grounds there thus encouraging migration to bigger coastal cities in the north-west and the south of the country.

Public health facilities exist in all the major coastal cities and to some extent in the smaller settlements along the coast (regional public health facilities are shown in table 3). In 1979, in Mogadishu, there were eight hospitals with 2,034 beds, ten dispensaries and mother and child health centres where free medical facilities are available. Out-patients generally buy their own medicines from the numerous pharmacies scattered throughout the city. In all District-level coastal settlements there are dispensaries with a few beds, but Merca, Kismayu, Bosaso and Berbera have their own hospitals. All these public health facilities are State funded. Formerly restricted private clinics are now permitted. Coastal populations are generally free from malaria and bilharzia, common in inland riverine and agricultural areas.

Mogadishu, Kismayu, Berbera and Merca have to some extent proper piped water supply systems and the rest of the coastal settlements use dug and drilled wells and public stand-pipes for their drinking water supply. In small coastal towns the water supply is not satisfactory in terms of either quality or quantity. Depending on location, water is obtained from traditionally dug wells or from a variety of surface water resources. Wells are from three to eighteen or twenty metres deep, tapping the uppermost aquifers. The water from this source is generally highly mineralized and not always potable, but in most cases it is suitable for watering livestock. Sanitary conditions are often below standard. Artificial reservoirs (wars) and local depressions (balleys) are also important sources of water supply. **Industrial water** supplies depend mainly on bore holes drilled specifically to meet the needs of the enterprises they serve. The discharge of bore holes ranges from 5 to 6 m<sup>3</sup> per hour.

Health control in all townships of the country is undertaken by the municipalities. Refuse is collected in containers which are transported by the municipalities to the outskirts of the town and the refuse is deposited on the dumping sites. There is no main sewerage system in Mogadishu and the use of septic tanks and soak-aways is common. The high water table during the rains causes some overflowing of the system.

The administration of water supplies is organized so as to take advantage of central planning and technical direction while at the same time decentralizing operational control. The autonomous agencies of the Ministry of Mineral and Water Resources are responsible for administration of the larger urban coastal water systems whereas Mogadishu and Kismayu have their own autonomous Water Development Agencies, which are expanding their water supply systems by means of foreign aid projects.

The objectives of the successive five-year national development plans have been:

- to raise the standard of living of the population;
- to provide employment opportunities;
- to accelerate growth in overall production so as to ensure an improvement of the per capita income;
- to reduce disparities between rural and urban populations in income and access to social services in order to discourage urban drift and prevent rising urban unemployment;
- to protect the environment and reverse the deterioration of crop lands and range lands, which leads to desertification, so as to improve productivity and ensure that productive activities based on these resources can continue in the future;
- to encourage popular participation in the development efforts.

Education in Somalia (table 4) is compulsory up to the Intermediate Level but free even up to University level. As already stated health facilities are provided free of cost in public hospitals and dispensaries.

The major coastal ports are Mogadishu - four freighter berths, one Ro-Ro berth, two under construction; Kismayu - four berths; and Berbera, berthing 350 m. About five hundred vessels use these ports annually and they cater to the transport of the country's imports and exports. The exports consist mainly of livestock, bananas, hides and skins, incense, meat and fish products (see table 5). The imports comprise

foodstuffs, crude oil, refined petroleum products, chemicals and machinery (see table 6). The three major ports handle 800,000 tonnes of products annually, and the types of vessels are livestock carriers for the country's trade in livestock with Saudi Arabia, estimated at about 1.3 million head of livestock, refrigerated vessels for the export of bananas to European markets, crude oil tankers and general cargo ships in addition to the occasional visits by Ro-Ro vessels and passenger ships.

In 1978 Mogadishu, the most important port, handled about 58 per cent of the total traffic. Berbera, Kismayu and Merca handled 25, 12 and 5 per cent respectively. The sector contributes significantly to invisible earnings. In 1979 about So. Shs. 30 million profit was generated by the four major ports. Smaller harbours such as Bosaso and Mait, which are frequented by smaller ships especially dhows, contribute to regional incomes. The sector is also a major employer with 959 permanent staff and 2545 casually employed stevedores.

#### COASTAL INDUSTRIAL DEVELOPMENT

The major coastal industrial complexes in the country are as follows:

- Mogadishu: edible oil mill, pasta factory, cigarettes and matches factory, milk bottling plant, oil refinery, aluminium factory, jesira power station, Somali chemical industry (soaps and detergents), pharmaceuticals plant, and urea plant.
- Kismayu : meat processing factory, freezer factory;
- Berbera : asbestos and cement sheet plant, pilot gypsum plant, cement factory;
- Laskoreh : fish processing and canning factory;
- Bolimog : fish processing factory;
- Qandala : fish processing and canning factory;
- Jesira : salt producing plant.

#### Oil refinery

There is a refinery called "Iraq Soma" situated about 14 km from Mogadishu which refines about 300,000 tonnes of crude per year. The crude is imported from the Middle East by 20,000 dwt - 100,000 dwt tankers. The refined products are mostly for local consumption but some heavy fuel oil is also exported (about 120,000 tonnes in 1978, for example).

#### Cement factory at Berbera

The cement plant at Berbera is under reconstruction for the purpose of increasing its production capacity from 100,000 to 200,000 tonnes of Portland cement per year. The cement produced will be for local consumption.

#### Milk factory

The milk factory at Mogadishu is designed to process about 40,000 litres of milk per day operating in two shifts. The products comprise pasteurized milk, yoghurt, fermented milk and cheese.

### Urea fertilizer plant

The urea fertilizer plant is under construction near Mogadishu. It will consist of ammonia synthesis and urea production units. At full capacity, 50,000 tonnes of urea will be produced per year and it will consume 30,000 tonnes of residual heavy fuel oil from the nearby refinery annually.

The country's industries are mainly for local consumption products and most of them are situated near major ports. Other important industrial complexes found inland are two sugar factories, one textile mill and one fruit processing plant, all situated on the banks of the country's two major rivers, the Juba and Shebelle. The effluent is generally disposed of under-ground and does not flow into the sea, for there is no proper sewage system.

In 1978, about 15,000 people were estimated to be working in industry. Most of the industries are State-owned except for the oil refinery and a few joint ventures.

### Desalination plant

In Quda, near Kismayu, there is a desalination plant benefitting the fishing resettlement community of that village. Ten other small desalination plants are planned for other similar fishing settlements along the coast.

## COASTAL AND INLAND HYDROPOWER AND WATER WORKS

The total area of Somalia is about 6.38 million hectares of which nearly 13 per cent is suitable for agriculture and 45 per cent for grazing, the remainder being non-agricultural land. Only a tenth of the land suitable for crops, i.e. about 700,000 ha, is currently utilized. Of this area only 50,000 ha are under controlled irrigation, mostly in the Shebelle and Juba river valleys. Another 110,000 ha are irrigated by uncontrolled floods and 540,000 ha are under rainfed cultivation.

Irrigation in a country with a semi-arid climate like Somalia is a very important factor and for this reason a number of dams have been constructed or are under construction in the riverine areas. In Jawhar, 90 km north of Mogadishu, on the Shebelle river, an offstream reservoir of 200 million m<sup>3</sup> capacity has been constructed to accumulate water during the rainy season; this water is later released into the Shebelle river during the dry season and used in the irrigation of the banana, grapefruit and sugar-cane plantations. There are also a number of small dams along the southern stretch of the Shebelle river for irrigating agricultural land in the Jannalle and Bulomarerta areas.

At Fanole, on the Juba river, there is a dam for the generation of hydro-electric power of 5MW capacity, and for the irrigation of 10,000 ha of agricultural land. Another dam is under construction in Bardhere on the Juba river for the control of the Juba waters and for the generation of hydro-power of 100MW capacity. The electricity generated by this dam is to be transmitted to Kismayu and Mogadishu. There are plans for other dams on the Juba river in the Sakow area and for the expansion of the Mordinle dam on the Shebelle river for rice cultivation.

The dams constructed on the Juba river for controlling the Juba flood waters, i.e., the Fanole, Bardhere and Sakow, are the only dams that may influence the coast and coastal waters, but no real studies have been conducted in this regard.

In the Shebelle and Juba riverine areas malaria and bilharzia are common because flood waters spread during the rainy seasons; it is hoped that these diseases might be somewhat controlled after the completion of the dams under construction, especially the Bardhere Dam.

## TRANSPORT

The modes of transport prevalent on land and in coastal waters are roads, sea and air. No internal waterways or railways exist; there are 18,000 km of roads throughout the country of which about 14 per cent are all-weather roads. Four ports handle the bulk of the country's cargoes and of these, three have deep-water quays. Presently, air transport serves ten regional centres of which four have tarmacadamized runways at Mogadishu, Kismayu, Berbera and Hargeisa. The first three are on the coast.

The principal means of transport for people and goods are buses, lorries and ships. Road transport is particularly important for internal trade as it links all the regions of the country and serves all sectors of the Somali economy. In the absence of railways and internal waterways the importance of these lorries and buses is enormous. Camels and donkeys are also widely used in rural areas for transporting goods. Camels are used for long-distance transport and donkeys for small loads within and near the cities. Also of major importance is transport by sea through the four principal ports since all foreign trade, import or export, is conducted in this way.

In 1980 the country's imports were valued at 2,190 million So. Shs. (table 6). The most important items were cereals and cereal products, animal and vegetable oils and fats, basic metals, non-edible animal and vegetables crude material, petroleum products, transport equipment and electrical machinery (imports include supplies for the 600,000 refugees in camps throughout the country).

Exports were valued in 1980 at 834.9 million So. Shs. (table 5). Principle exports are livestock, bananas, meat and meat products, hides and skins, fish and fish products, myrrh and incense, etc.

The national fleet consists of two coasters and two banana carriers varying in size from 941 GRT to 5,170 GRT. The Somali Government owns jointly with a Greek company a livestock carrier of about 12,000 GRT. Servicing of vessels using Somali ports is a function of the Government-owned Somali Shipping Agency which employs 116 people in its Mogadishu, Berbera and Kismayu offices.

Transport by coastal shipping between points in the country is limited, for there is little inter-regional trade suitable for shipping since most of the goods are transported by lorry. However, there is a certain amount of coastal navigation in the Gulf of Aden area where dhows cater for trade between coastal settlements.

Two additional 330 metres berths are planned to be added to the port of Berbera and construction has already begun. Kismayu port, which handles 60 per cent of banana exports and 15 per cent of livestock exports and which has four berths, is also going to be extended and rehabilitated. In Mogadishu port, the erection of two new transit sheds is planned in order to increase the present but inadequate storage capacity. More covered storage areas are needed to reduce damage to goods especially from rain. There are also plans to construct a deep-water port at Merca.

## EXPLOITATION OF TERRESTRIAL BIOLOGICAL RESOURCES

Mangroves are found in the extreme south of the country, north of the Kenyan border, and are harvested by the local population, transported by dhows and sold to nearby coastal settlements, like Kismayu, where they are used for the construction of ancestral houses (arish). Because of the traditional nature of this trade no precise data have been compiled on the extent of mangrove exploitation or on related economic aspects.

Agriculture is carried out only in the coastal zones of Kismayu along the Juba river where extensive banana and coconut plantations are found and where maize is also cultivated. Bananas are mostly exported to European markets while cereals and coconuts are used by the local population for food and extraction of oil.

Animal husbandry in the coastal areas throughout the country is pursued by the traditional nomads. Camels, cows, goats and sheep are commonly seen in these areas and Mogadishu, Kismayu and Berbera ports are used for the export of livestock to Saudi Arabia and other Arab countries.

At present the use of fertilizers is negligible, but in the coastal area along the Juba river, where extensive banana plantations are found, rather large amounts of urea are used. With the completion of the new urea fertilizer plant more fertilizers will be utilized in the future, especially in the sugar-cane and banana producing areas of the Juba river, which, as mentioned previously, flows into the sea near Kismayu. The use of pesticides is limited to banana and sugar-cane plantations and, to some extent, maize fields along the Juba river.

The number of people involved in agriculture and animal husbandry in the coastal zones is estimated at 200,000. Most farmers keep to the traditional methods of farming with a hoe; animals are not used much in agriculture since modern farming methods are used in banana and sugar-cane plantations.

## FISHERIES

Artisanal fishing is carried on throughout the coastal areas within a limited distance from the shore, while trawling is practised in areas with suitable bottom configuration. The main trawling area is between Ras Hafoon and Eil where the continental shelf is estimated at 35-40,000 km<sup>2</sup>. Catches by the artisanal and industrial sectors are currently estimated to be about 14,000 tonnes per year, 30 per cent of which is the artisanal sector's contribution (mainly sharks, large tunas and mackerels). The industrial sector concentrates on demersal species, which include snappers, groupers and deep-sea lobsters. Estimates of potential production suggest that a total national catch of about 180,000 tonnes could be achieved if only fishing boats of 7-9 metres length were used. But it is estimated that the Somali coast could yield between 750,000 to 2,000,000 tonnes of fish per year if a sufficient number of trawlers were used in addition to the small fishing boats. Potential catches could be broken down as follows:

Tunas and mackerels	8 000 tonnes
Small pelagics	100 000 t
Large demersal	40 000 t
Sharks and rays	30 000 t
Spiny lobsters	1 500 t
Mesopelagic	Not known

In addition, there are undetermined but probably small quantities of turtles and cephalopods. A break-down of catches is available only for 1976 and is as follows:

Local boats

Tuna for canning	4 000 t
Sharks for drying	1 500 t
Demersal bony fish	1 500 t
Lobsters	50 t

Trawlers

White frozen fish	1 300 t
Frozen lobsters	600 t

The population depending exclusively or partially on fishing is estimated at 1.8 per cent of the nation, i.e. about 90,000 people scattered throughout small coastal settlements.

There are a number of fish processing industries in the country; the most important of these are the Laskoreh fish cannery, the Bolimog fish factory; the Prodma fish processing factory, and the Habo and Qandala tuna canneries.

The Laskoreh Factory is designed to handle about 40 tonnes of tuna daily. About half the daily intake can be processed through the canning lines and the remainder is frozen and placed in cold storage. This is done in order to accumulate a stock of up to 800 tonnes during the course of the October-May fishing season, thus enabling the processing to continue for some time during the off-season. Normally, fish waste from the processing line of any unmarketable fish is disposed of by processing into fish meal and oil. The canning lines produce mostly tunas, mackerels and sardines.

The Bolimog factory comprises a processing system of four blast freezer tunnels with a total capacity of 50 tonnes a day at minus 40°C, cold storage capacity of 2500 tonnes of fish at minus 20°C, a fish mill plant with a capacity of 25 tonnes per day and centrifugal type oil recovery plant. This factory can handle up to 10,000 tonnes of frozen fish and 5,000 tonnes of fish meal and oil.

The Prodma Factory at Kismayu has a blast freezer and a cold storage capacity of 250 tonnes at minus 25°C. In addition to buying lobsters, it takes in catches of frozen offshore lobsters and selected fish species from a number of freezer trawlers and exports the produce. This factory was built in 1968.

Each of the factories at Habo and Qandala has a capacity of 30 tonnes a day and can also hold up to 15 tonnes of fish in chilled storage from one day to the next. The processing system is basic and simple and all machine operations on the canning lines can be duplicated by hand if necessary so that a mechanical breakdown does not necessarily prevent continued processing. The two tuna canneries were built by the Italians back in 1936.

The per capita consumption of the country is estimated at less than two kilograms per head annually; the bulk of the fish catch is destined for foreign markets. Consumption of meat per capita is substantially higher than fish due to the nomadic background of the overwhelming majority of the population and the abundance of livestock. There are an estimated 25 million head of sheep and goats, 3.7 million cattle and 5.3 million camels in the country.

The export of fish and fish products was valued at 15.6 million So. Shs. in 1976. There is no evidence of fish farming or aquaculture.

There are many trawlers using the country's economic zone. An Italian 60 m stern freezer trawler, the Antonietta Madre, which is licensed under a joint agreement between the Delta Co., the Ministry of Fisheries and the coastal development project, carries out offshore fishing. Two Australian-built vessels, under a joint venture with Somalfish and Straits Fisheries of Singapore, fish offshore for lobster and other fish species and land their frozen catch in Kismayu and Mogadishu. In addition, there are a number of Japanese, Italian and Greek trawlers busy fishing in Somali waters under licence from the Ministry of Fisheries.

The sanitary control of fishing products is carried out by doctors employed by the local government councils in the regions and districts.

### MINERAL EXPLORATION AND EXPLOITATION

Somalia is situated in one of the highly mineralized areas of Africa, but at present the minerals sector contributes less than one per cent to the country's gross domestic product.

Mineral oil exploration has been proceeding since the 1940s. Up until 1980, some 54 wells have been drilled mostly in coastal and offshore areas and there has been some evidence of oil and gas in fifteen of the wells.

A uranium exploration project has been under way since 1978 covering an area over 54,000 km<sup>2</sup>. To date, 10,000 tonnes of uranium concentrates have been located in the Galqudud and Mudug regions, for which a suitable leaching method has been found. Significant iron ore deposits have been located in the Bur area and are presently being investigated for their extent and quality.

Significant results have been achieved and the exploitation of several minerals has been found to be feasible. Current exploitation consists mainly of salt production along the coast and quarrying for lime, sand and other building materials close to centres of population.

Sand extraction and lime quarrying are quite extensive in the coastal areas close to Mogadishu where a construction boom is going on. Although the amount of sand and lime involved is considerable, no reliable data are yet available. Removal of these materials from beaches and coastal rocky areas is quite widespread and generally detrimental to the coastal environment, for it causes soil erosion and air pollution by the spread of dust particles.

In Berbera extraction of cement-bearing rocks to feed the local cement factory has a detrimental effect on the local environment as it causes erosion and pollutes the air with cement particles.

### TOURISM

At present tourism makes a negligible contribution to the country's economy. Available information on restaurants and hotels is limited to State-owned establishments although there are a number of small, privately-owned hotels and



facilities. Of the eleven State-owned hotels in the country, nine are found in coastal areas. In Mogadishu, there is a total of eleven major hotels, including State and privately-owned hotels, with 1,154 beds. The average annual occupancy in these hotels is about 50 per cent.

It is estimated that about 4,000 persons are employed in hotels and restaurants. It is anticipated that the private sector will make an important contribution to the development of tourism. There are a number of hotels under construction or already in operation in Mogadishu. Most tourist facilities are located in the capital and are utilized by visitors who come to Somalia for business, conferences and official reasons not having to do with tourism.

#### OTHER ACTIVITIES RELEVANT TO ENVIRONMENTAL QUALITY

Sand-dunes fixation is an important activity being carried on in the coastal areas to protect the environment. Seven thousand hectares of sand dunes have been stabilized under World Food Programme Project 719, but this constitutes negligible progress towards solving the overall problem of sand dunes which are estimated to cover 500,000 ha. The project, which is going on in the Shalamood coastal area, will establish a viable and continuing programme for the arrest of sand dune encroachment and fixation of dunes. It will do this by determining the exact extent of dune encroachment and the causes of dune formation, developing cheaper and simpler fixation techniques that utilize economically useful species, and by laying down guidelines for the organization, monitoring and evaluation of fixation, management and utilization activities.

Table 1: Gross domestic product by kind of economic activities  
(So. Shs. million at current prices)

I T E M S		1970	1977	1978	1979	1980	1981
I.	AGRICULTURE	1,066.1	3,192.6	3,742.2	3,256.1	4,067.3	6,899.0
	1) Crop Production	356.7	553.0	587.8	680.3	810.4	1,027.1
	2) Livestock	547.4	2,366.0	2,858.4	2,213.2	2,738.3	5,133.6
	3) Forestry	158.0	253.0	287.0	339.0	467.0	672.0
	4) Fishing	4.0	20.6	9.1	23.6	51.6	67.3
II.	MINING & QUARRYING	23.0	40.0	28.0	36.0	43.2	68.0
III.	MANUFACTURING	186.2	439.0	433.2	457.9	574.3	850.0
	Small establishments	81.2	158.0	165.0	174.4	218.7	323.7
IV.	ELECTRICITY & WATER	15.1	45.8	43.7	50.2	58.0	126.8
V.	CONSTRUCTION	105.0	302.0	206.0	283.1	389.0	506.0
VI.	TRANSPORT & COMMUNICATIONS	133.1	324.8	302.3	364.6	772.4	1,122.1
VII.	TRADE & RESTAURANTS	171.9	477.3	686.6	702.2	1,027.6	1,508.9
	1) Trade	157.4	443.7	646.3	648.2	933.0	1,359.9
	2) Hotels & Restaurants	14.5	33.6	40.3	54.0	94.6	149.0
VIII.	FINANCE, INSURANCE	90.5	311.5	450.2	553.8	670.0	1,022.4
IX.	OTHER SERVICES	51.6	148.6	169.6	216.1	361.0	660.0
X.	GOVERNMENT SERVICES	147.5	407.0	692.7	727.7	874.0	1,151.0
	GDP at Factor Costs	1,990.0	5,688.6	6,754.5	6,647.7	8,836.8	13,914.2
	Indirect Taxes	253.5	649.6	1,154.5	1,286.8	1,147.4	2,146.9
	GDP at Market Prices	2,243.5	6,338.2	7,909.0	7,934.5	4,984.2	16,060.6

Table 2: Development 1982 - 1986

	(So. Shs. million)	%
I. AGRICULTURE		
Livestock	2,433.3	14.9
Crop Production	723.4	4.4
Irrigation	4,036.0	24.8
Forestry	57.5	0.3
Fisheries	437.7	2.6
II. MINING AND MANUFACTURING	2,646.6	16.2
Mining	557.1	3.4
Manufacturing	2,089.7	12.8
III. INFRASTRUCTURE	3,045.5	18.7
Energy and Power	684.9	4.2
Water Resources	1,628.5	10.0
Transport and Communication	732.1	4.5
IV. OTHER ECONOMIC SECTORS	711.7	4.4
Tourism	257.1	1.6
Trade	454.6	2.8
V. SOCIAL SECTORS	1 509.8	9.3
Education	1,090.1	6.7
Health	338.0	2.1
Manpower & Employment	34.0	0.2
Statistics	36.3	0.2
Information	11.4	0.1
VI. REGIONAL PLANS	701.9	4.3
ADJUSTED TOTAL	16,303.6	100.0

Table 3: Number of doctors, medical assistants, ambulatory hospitals, hospital beds and MCH centres by regions, 1979

REGIONS	D O C T O R S		Medical Assistants	Ambula-tories	Hosp-itals	Hospital Beds	MCH Centres
	Non-Somali	Somali					
Banadir	34	118	23	10	8	2,034	10
Bay	2	6	2	15	4	169	4
Bakol	-	4	1	7	4	146	3
Gedo	1	6	3	15	5	69	4
Mudug	5	2	3	7	1	60	5
Hiran	6	5	1	11	5	261	3
Sanag	-	2	-	4	3	98	3
Togdher	1	4	2	9	3	288	4
North-West	9	13	6	14	10	941	6
Nugal	-	3	5	4	3	132	5
Middle Shabelle	1	4	4	16	4	132	6
Lower Shabelle	2	12	11	44	10	682	11
Galgadud	-	3	4	4	5	80	4
Bari	-	2	2	17	6	77	4
Middle Juba	-	7	4	20	4	232	4
Lower Juba	6	5	3	20	5	210	4
TOTAL	67	196	74	217	80	5,611	75

(Source: Ministry of Health)

Table 4: Education by level 1978 - 1979

Level of education	SCHOOLS		ENROLLMENT		TEACHERS		CLASS ROOMS		
	Schools	Classes	Male	Female	Male	Female	Occu-pied	Unoccu-pied	Total
Pre-Elementary	18	54	5,296	2,757	146	137	15	45	60
Elementary	820	3,867	148,361	56,798	4,014	1,225	2,606	242	2,848
Intermediate School	618	2,989	115,390	38,402	4,127	845	2,152	492	201
Secondary Schools									
a. General	36	282	11,130	2,373	706	35	232	71	303
b. Tech.Vocation	14	127	4,430	1,098	333	43	114	4	118
c. TTC	2	65	2,856	902	162	9	65	-	65
d. Correspondence	1	-	2,385	988	25	6	-	-	-
Women Education	51	175	3,714	3,714	300	291	143	11	154
Adult Education	-	768	27,083	14,314	*	*	*	*	*
TOTAL	1,561	8,327	320,645	121,316	9,813	2,591	5,357	392	5,749

(\*) Shared with primary school

(Source: Ministry of Education)

Table 5: Exports in value (So. Shs. millions)

I T E M S	1976	1977	1978	1979	1980
Bananas	178.7	54.6	54.6	54.0	68.8
Livestock	281.2	279.5	588.7	555.2	639.5
Cattle	71.9	41.7	100.9	135.8	156.7
Sheep	80.9	95.5	192.3	188.6	217.4
Goats	79.0	94.1	254.9	190.8	218.7
Camels	49.4	48.2	40.5	40.0	46.7
Meat and meat products	43.0	13.3	0.3	5.9	10.4
Hides and skins	51.0	9.5	11.7	53.1	42.1
Wood products	-	-	-	-	-
Fish and fish products	15.6	9.4	2.5	3.7	2.8
Others	26.0	30.3	13.0	32.0	71.3
TOTAL	596.6	396.6	670.8	703.9	834.9

(Source: Central Statistical Department)

Table 6: Imports by commodities in value (So. Shs. millions)

I T E M S	1976	1977	1978	1979	1980
Cereals and cereal products	134.1	191.4	31.1	73.1	381.4
Fruit and vegetables	5.0	6.3	7.9	9.7	15.8
Animal and vegetable oils and fats	41.4	51.4	32.0	25.6	151.7
Non-edible animal and vegetable crude material	29.5	36.1	34.0	115.0	94.6
Sugar and sugar products	1.4	1.6	78.4	11.0	31.6
Coffee, tea, cocoa	22.3	20.7	32.4	32.2	29.8
Beverages and tobacco	22.9	19.9	64.2	77.6	38.3
Petroleum and petroleum products	66.5	61.4	100.5	78.8	35.0
Medical and pharmaceutical products	27.9	47.5	21.3	34.2	38.0
Chemical and rubber products	74.6	91.4	74.1	41.3	28.8
Paper and rubber products	27.2	51.7	16.2	24.2	27.7
Wood, lumber and cork	13.4	19.5	4.4	13.5	14.6
Textiles	35.7	52.0	68.2	67.6	36.6
Clothing	8.7	22.1	41.0	32.2	31.6
Basic metals	33.7	93.1	29.3	64.4	10.0
Metallic and mineral manufactures	77.7	98.6	163.3	72.8	4.9
Electrical machinery	31.9	118.5	59.8	68.0	18.4
Non-electrical machinery	93.9	196.7	112.7	138.4	12.1
Transport equipment	150.2	195.0	298.3	304.6	42.8
Miscellaneous manufactures, others	82.0	93.1	110.7	263.9	29.5
TOTAL	978.9	1432.8	1519.9	1545.8	1034.6

(Source: Central Statistical Department)

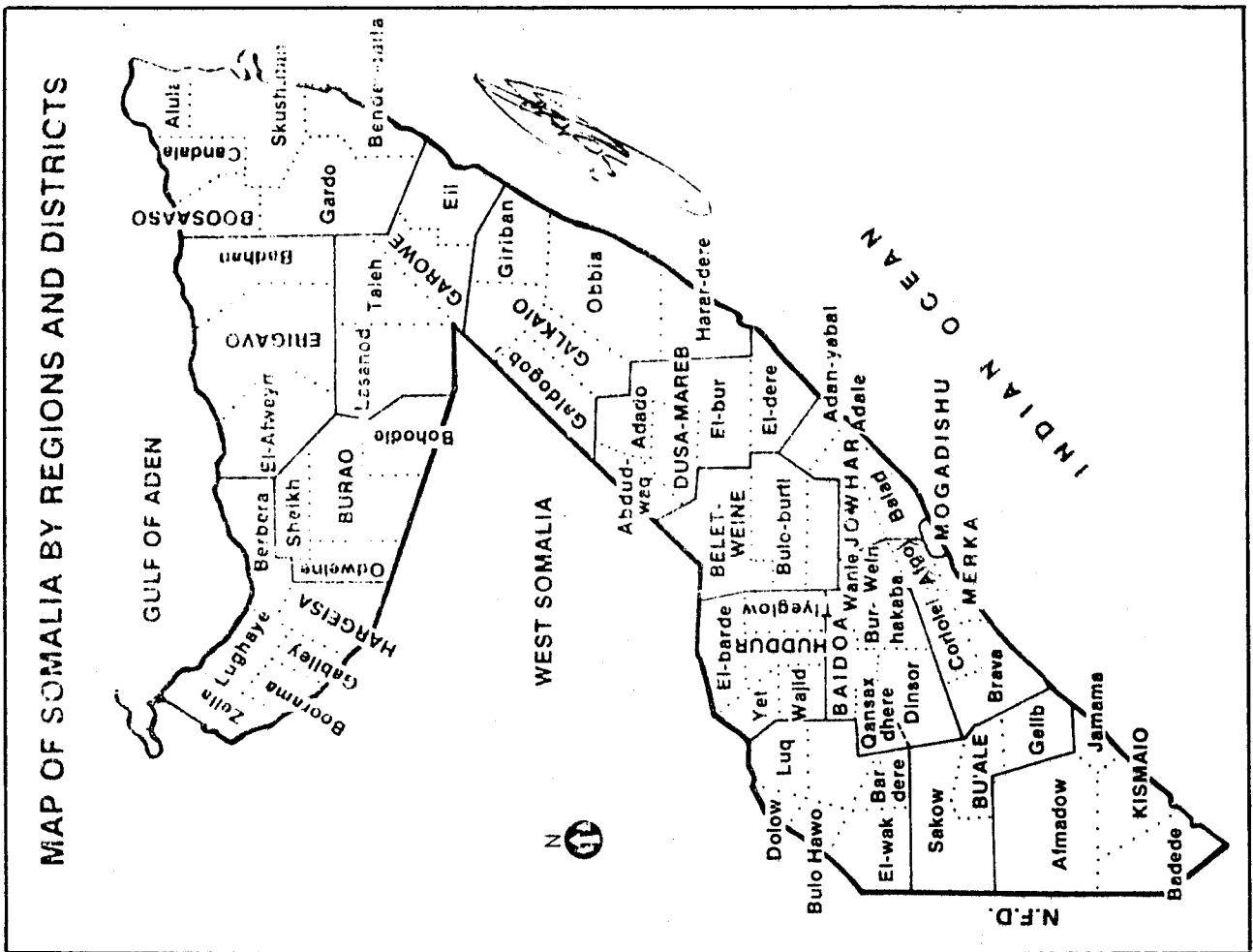

FIGURE 1

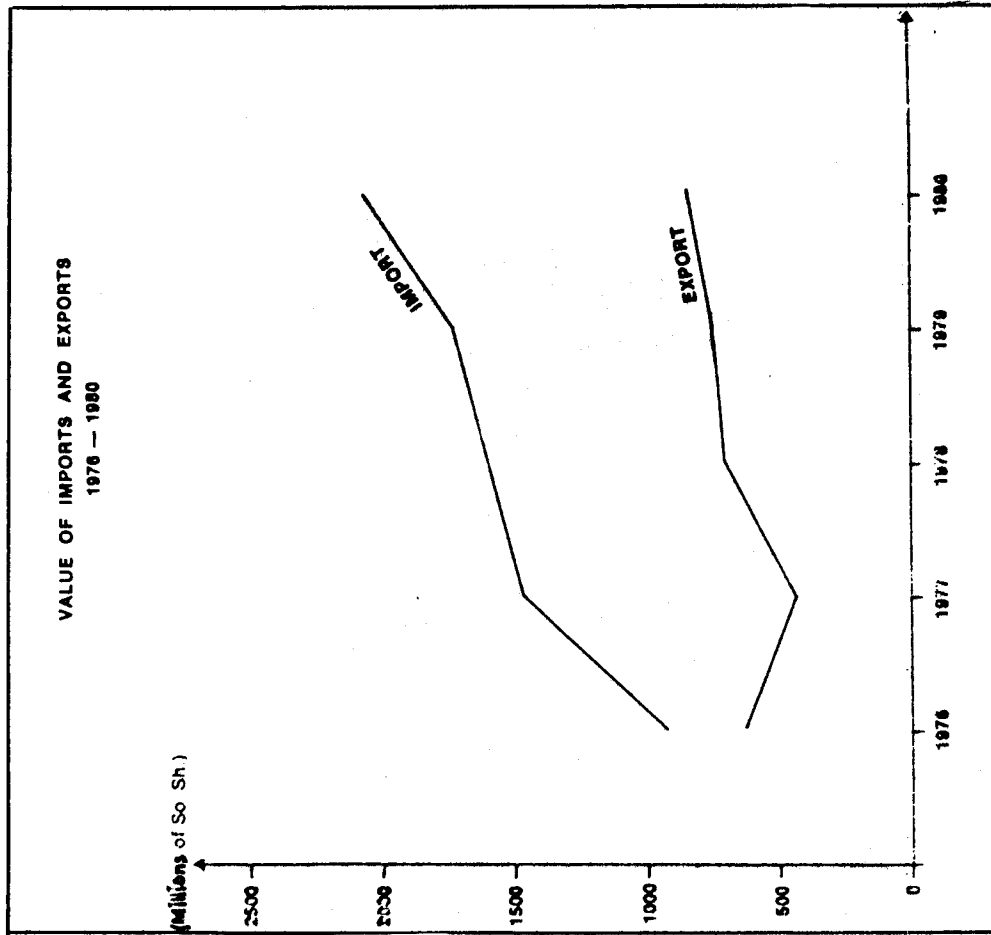
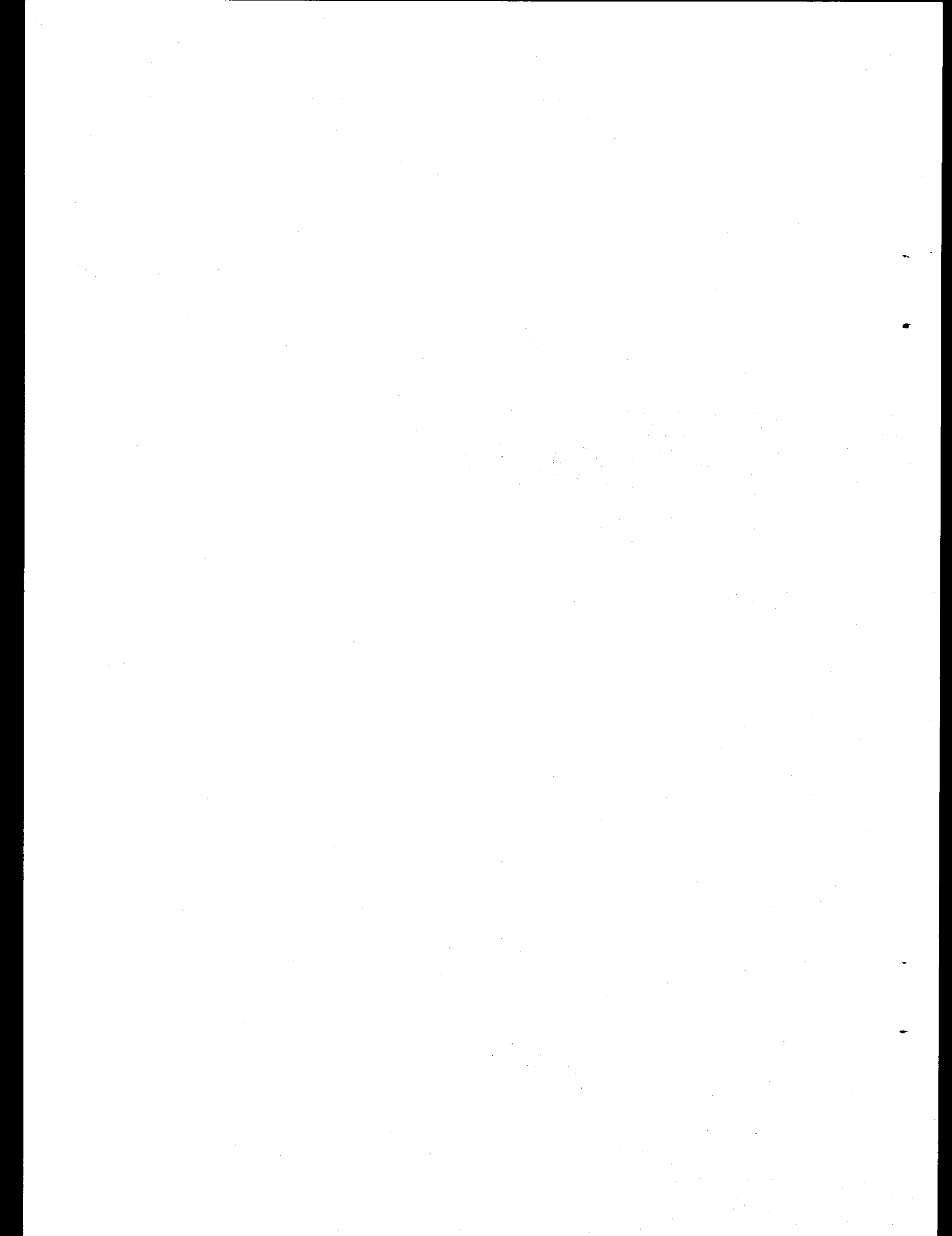

FIGURE 2



RAPPORT NATIONAL FRANCAIS (LA REUNION) : par M. Conan

DONNEES DE BASE

L'Ile de la Réunion dans l'Océan Indien est caractérisée par l'absence de plateau continental avec 250 km<sup>2</sup> de fonds inférieurs à 100 mètres contre 2000 km<sup>2</sup> à Maurice, avec un entourage de fonds de plus de 4000 mètres, ainsi que par l'importance du relief et de l'érosion intérieure de l'île. Ces facteurs déterminent de façon notable les formes littorales qui comprennent pour une longueur de 260 kilomètres:

- 93 kilomètres de falaises dont 48 de falaises vives;
- 13 kilomètres de côtes rocheuses basses;
- 59 kilomètres de côtes de galets;
- 35 kilomètres de plages de sable dont:
  - 14 kilomètres de sable dunaire basaltique,
  - 9 kilomètres de sable corallien avec platier,
  - 12 kilomètres de sable corallien avec lagon et récif corallien
- 8 kilomètres de côtes correspondant à des alluvions de comblement de type lagunaire.

Aussi, à la différence des autres îles des Mascareignes, la morphologie de l'île de la Réunion est surtout marquée par des cordons alluvionnaires et des falaises et par la localisation des côtes sableuses avec souvent une barrière corallienne sur la côte ouest.

Le littoral subit l'influence du déplacement de la houle d'alizé qui arrive au contact des côtes réunionnaises. Deux mouvements sont créés de part et d'autre de l'île qui se rejoignent dans le nord-ouest à la Pointe des Galets.

Enfin, il est à noter que des houles exceptionnelles telles que les houles cycloniques, peuvent faire varier de façon brutale la morphologie littorale. Cette modification étant par la suite atténuée par les houles d'alizé.

DEVELOPPEMENT DES ZONES URBAINES ET RURALES

La population réunionnaise vivant sur la littoral, se répartit sur 19 des 26 communes du département avec:

- dans la zone des 500 mètres:
  - 67 600 habitants pour 15 200 logements principaux et 780 résidences secondaires;
- dans la zone des 2 kilomètres:
  - 222 500 habitants pour 50 100 logements principaux et 1 030 résidences secondaires.

Le littoral réunionnais est donc très occupé mais cette occupation est un phénomène ancien qui, au moins dans la bande de 500 mètres n'a pas tendance à trop s'aggraver en valeur relative.



Le nombre des villes côtières les plus habitées sont :

- plus de 100 000 habitants: 1 (St-Denis);
- entre 50 et 100 000 habitants: 2 (St-Pierre, St-Paul);
- entre 10 et 50 000 habitants: 9;
- moins de 10 000 habitants: 7.

Cependant, les calamités naturelles telles que cyclones et sécheresse, ont déterminé certains habitants agriculteurs des hauts à émigrer vers les villes côtières. Cet exode a entraîné une certaine désorganisation dans la voirie urbaine. Aussi, depuis dix ans, les municipalités ont-elles fait un gros effort dans le domaine de la distribution de l'eau et surtout dans l'assainissement en installant le tout à l'égout, des usines de traitement des eaux et d'ordures ménagères.

Usines de broyage/compostage pour 1982

St-Denis 150 t/jour. Le retournement des andains s'est révélé impraticable en l'absence d'un criblage des ordures broyées. Actuellement, elles sont utilisées en broyage grossier avant décharge aménagée à la Jamaïque. Une meilleure utilisation (tri, autre méthode de compostage) est à l'étude.

Le Port. L'usine tourne actuellement au tiers de sa capacité et mériterait que sa vocation intercommunale s'élargisse. La présence d'un crible (maille 200 mm) crée 40 pourcent de refus mais permet l'obtention en un mois d'un compost de bonne qualité utilisé en totalité en pépinières, cependant, le problème de mise en décharge de refus subsiste.

Décharges contrôlées

Outre la décharge "aménagée" de produits broyés à St-Denis non réglementaire mais peu nuisante, il existe une autre à Trois-Bassins. Des projets d'installation contrôlée sont à l'étude à St-Leu, St-Louis, St-Pierre, St-Benoît, St-André, Plaine des Palmistes et Plaine des Cafres. Des prospections sont également en cours à Salazie, Petite-Ile et St-Joseph et une recherche d'ensemble de sites intercommunaux sur le département devrait être confiée au B.R.G.M.

Décharges brutes et sauvages

Chaque commune possède en général un à trois dépôts bruts importants, avec brûlage, situés soit en ravines ou en forêts soit sur le littoral où se forment de véritables "corps" d'ordures, que les houles cycloniques étalent ensuite sur des kilomètres. Les écarts non desservis par la collecte ont eux aussi leurs dépôts sauvages auxquels s'ajoutent les ferrailles et carcasses de voitures.

Stations d'épuration de capacité de plus de 500 équivalents-habitants:

- St-Denis 100 000 eq/habitant avec décantation primaire et traitement aéobie des boues;
- Ste-Marie: Station Lotissement Grande Montée et Station de la base aérienne de Gillot sur le principe des boues activées;
- St-André (2), St-Benoît (2), St-Louis (2), St-Pierre (1), St-Paul (54), le Tampon (1), possèdent aussi le même genre de stations;

- certaines communes telles que St-Pierre ont installé une station communale (15 000 eq/habitant) avec décantation primaire plus stabilisation avec aérobie des boues, le Tampon avec la Station Lotissement Ligne des 400 et celle du Lycée Roland Garros dont le principe repose sur le lit bactérien à forte charge (monobloc eau et assainissement).

Cependant de nombreux problèmes existent parmi lesquels:

- la lenteur du branchement des usagers comme par exemple à St-Paul ou St-Benoit où moins de 30 pourcent des gens ont été raccordés en quatre ans;
- l'abaissement de prétraitements efficaces pour les abattoirs, cantines, laiteries, garages, etc.;
- les mauvais branchements d'où du sable dans les réseaux et des ennuis divers divers lors des grosses pluies;
- les fermentations dans les réseaux;
- les turbines d'aération et cheminées de décanteurs mal conçues.

#### DEVELOPPEMENT INDUSTRIEL DU LITTORAL

Le phénomène marquant en matière de localisation des zones d'activité est le grave déséquilibre constaté entre le pôle de St-Denis - le Port et le reste de l'île. Ainsi, sur 230 hectares de zones industrielles équipées sur l'île, les deux communes du port et de St-Denis regroupent 180 hectares, soit près de 80 pourcent des possibilités d'accueil. Cette prépondérance s'explique par deux facteurs:

- Le Port est le point de passage quasi obligatoire des marchandises en provenance ou en direction de l'extérieur de l'île;
- St-Denis est le pôle administratif, politique et de services de l'île qui regroupe de surcroît 20 pourcent environ de la population totale.

A ces deux facteurs, s'ajoute la proximité de ces deux villes reliées par une voie littorale rapide alors que les autres centres urbains, St-Paul mis à part, sont nettement plus distants. Il est donc normal et pour des raisons évidentes, que les entreprises aient eu plutôt tendance à se regrouper au Port et à St-Denis pour bénéficier du maximum d'avantages. Il est cependant à noter que les industries agro-alimentaires, donc peu liées à l'import-export, s'installent dans le sud où les communes leur proposent des conditions d'installation très avantageuses. Mais il est bien certain que, malgré tout, un déséquilibre existe et existera toujours entre le nord et le sud, si une politique d'aménagement volontariste du secteur secondaire n'est pas mis en place dans les années à venir.

Il est cependant évident que la faible industrialisation du département n'a pas empêché des pratiques déplorables liées souvent à une absence de contrôle réglementaire difficile à mettre en oeuvre, liée parfois au chantage économique. Les rejets des usines se sont toujours faits en direction des rivières, des étangs (St-Paul, le Gol) et de la mer. Ainsi, jusqu'à 1981, les usines sucrières fonctionnant de juillet à décembre, ne faisaient l'objet d'aucune réglementation. Aussi, les régions avoisinantes se trouvaient-elles assaillies par la fumée, les

escarbilles et les odeurs malodorantes; le rejet des vinasses acides, des eaux chaudes dont la température étaient de plus de 50°, s'effectuait sans trop de contrôle hypothéquant la faune et la flore de certains étangs (St-Paul, le Gol, etc.). Avec la concentration de l'industrie sucrière une meilleure compréhension du problème pollution par les "sucriers", a permis et permettra de solutionner lentement ce problème.

Cependant, l'industrie sucrière n'est pas la seule en cause. Certaines industries alimentaires exercent leurs activités en dehors de toute préoccupation de protection de l'environnement. Les cours d'eau voisins se trouvent pollués (Rivière Saint-Denis). De même, les déchets de quelques usines plastiques sont brûlés dans une zone habitée, les garages de réparation automobile installés dans les villes noircissent les caniveaux avec le rejet des huiles de vidange, etc.

### OUVRAGES HYDRAULIQUES

La Réunion étant une petite île volcanique, les cours d'eau sont relativement courts et leurs débits instables sont soumis aux aléas de la saison dite cyclonique. Ainsi, les débits pourront varier pour:

- Le Bras de la Plaine	de 6	à	200 m <sup>3</sup> /s
- Le Bras de Cilaos	de 3	à	220 m <sup>3</sup> /s
- La Rivière Saint-Denis	de 0.8	à	350 m <sup>3</sup> /s
- La Rivière des Marsouins	de 5	à	550 m <sup>3</sup> /s
- La Rivière des Roches	de 5	à	750 m <sup>3</sup> /s
- La Rivière de l'Est	de 6	à	900 m <sup>3</sup> /s
- La Rivière des Galets	de 2,6	à	950 m <sup>3</sup> /s
- La Rivière du Mât	de 8	à	1,700 m <sup>3</sup> /s

Les principaux ouvrages hydrauliques se trouvent sur la côte est (Takamaka et Rivière de l'Est) où le débit permet un approvisionnement correct. Les effets de nuisance sont faibles sur la nature et la santé publique, la D.D.A.S.S. faisant des contrôles systématiques qui montrent le peu d'incidence de ces ouvrages et retenues. Cependant, il reste à l'heure actuelle environ 30 000 branchements à réaliser et la prévision de consommation électrique en 1990 sera de 900 000 kilowatts-heure, les équipements étant à l'heure actuelle capable de fournir 740 000 kilowatts-heure.

Il sera donc nécessaire de:

- (a) renforcer la centrale thermique du port qui passera de 154 MW à 300 MW;
- (b) effectuer des aménagements hydrauliques avec Takamaka-Amont et captage de Bras-Cabot de Takamaka-Aval et Celui de Grand-Etang. Ce dernier aménagement consisterait à créer une retenue de 10 à 20 millions de m<sup>3</sup> d'eau qui pourraient être turbinés dans l'usine de Takamaka actuel et le future Takamaka-Aval permettant l'équivalent d'un stockage de 10 à 20 M kWh. De plus, l'usine de Beaufonds produira 35 M kWh en saison de la coupe de cannes à partir de la bagasse. Enfin, des études sont entreprises pour la fourniture d'énergies nouvelles à partir de la géothermie et du solaire.

## LES TRANSPORTS

En ce qui concerne le département de la Réunion, les transports, qu'ils soient de voyageurs ou de marchandises, sont uniquement assurés par route:

- par des transports réguliers;
- par des transports spécialisés (scolaires ou entreprises);
- par des transports occasionnels;
- par des taxis.

Si, il y a quelques décennies, le département disposait d'une voie ferrée, ceinturant l'île de St-Benoit à St-Pierre en passant par St-Denis, compte-tenu de la vétusté des infrastructures et du matériel, elle est depuis plusieurs années abandonnée. Le cabotage est quant à lui totalement inexistant.

Bien que disposant d'un réseau routier d'excellente qualité, cette politique de transport uniquement axée sur la route se traduit, lors des périodes cycloniques, par des perturbations importantes dans les déplacements, notamment entre le port, poumon de l'île, et St-Denis la capitale. De plus, l'absence de mode de substitution (tous les transports dépendent des produits pétroliers) dans l'hypothèse d'une pénurie de carburants, pourrait se traduire par une désorganisation complète des communications dans l'île.

Les transports réguliers sont exploités par 25 entreprises. Le nombre total de véhicules pour ces voyageurs est de 353, le nombre de places offertes s'élevant à 14 438, soit une moyenne de 41 places par véhicule. Les fréquences diffèrent suivant le type de ligne, surabondantes sur la ceinture du littoral parfois insuffisante pour la desserte des écarts.

Si l'on se réfère aux données recensées auprès des transporteurs, on peut estimer que 30 000 personnes empruntent chaque jour ce mode de locomotion, le taux de remplissage moyen des véhicules en 1981 est de 52,5 pourcent. Cependant, des variations importantes existent suivant les zones géographiques desservies, les services situés sur la ceinture du littoral St-Benoit - St-Pierre en passant par St-Denis, présentant des taux d'occupation pouvant atteindre dans certains cas 75 pourcent.

A partir d'enquêtes réalisées sur le terrain, on a pu quantifier le trafic journalier par autocar pour le littoral:

- lignes desservant St-Paul - La Possession - St-Denis: 5 100 personnes;
- lignes desservant St-Denis - Rivière des Pluies - Moufia: 2 200 personnes;
- lignes desservant St-Pierre - St-Denis: 900 personnes;
- lignes desservant Saline - St-Pierre: 150 personnes;
- lignes desservant St-Leu - St-Paul: 160 personnes.

Cependant, on "semble" assister à une diminution de la fréquentation de ce mode de transport provenant de l'augmentation élevée du taux de motorisation (900 immatriculations par mois) et de la concurrence des taxis.

### Les taxis

Leur nombre oscille entre 430 et 440, ce qui représente environ un taxi pour 1 000 habitants. Dépourvus généralement de taximètres, ils fonctionnent en taxis collectifs dans les zones où la demande est forte, c'est-à-dire la zone littorale.

### Les transports scolaires

Le nombre d'enfants scolaires (primaire plus secondaire) est d'environ 160 000. Moins de 20 pourcent de cette population ouvrent droit au transport scolaire, c'est-à-dire bénéficient de la subvention d'état. Si pour l'année scolaire 1979-1980, près de 27 000 élèves ont été transportés, il est à noter que la progression dans les dernières années a été multipliée par 2,5; elle s'est considérablement ralentie depuis cinq ans et s'oriente vers une stabilisation.

Si pour le voyageur, le transport routier concentré sur la côte est à peu près satisfaisant tant du point de vue voyageurs que marchandises, le département ne possède, bien qu'étant une île, qu'un seul port: le port de la Pointe des Galets. Créé en 1885, ce port est entièrement artificiel, creusé à l'intérieur des terres, dans les alluvions du cône de déjection de la Rivière des Galets à proximité de la pointe du même nom qui sépare les deux baies les mieux abritées de l'île: celle de St-Paul au sud et celle de la Possession au nord. Les bassins sont symétriques au chenal d'accès et à la zone d'évitages. L'ensemble couvre une superficie de 15 ha dont 30 ha de plan d'eau et comporte, en gros, trois parties:

- les bassins nord où on trouve les quais à marchandises diverses, l'apportement pétrolier, le silo à ciment, les cuves de stockage du bitume en vrac, etc.;
- le bassin sud affecté aux marchandises générales;
- la darse de pêche où la participation est essentiellement étrangère (formosans, coréens, japonais).

Les principales denrées importées (1981) en tonnes sont:

Viandes et poissons	5 700 tonnes
Laitages	5 400 tonnes
Fruits	7 500 tonnes
Maïs, riz	82 000 tonnes
Huiles végétales	5 600 tonnes
Eaux	9 000 tonnes
Vins	9 000 tonnes

Pour l'exportation:

Sucre	175 000 tonnes
Mélasses	30 000 tonnes
Rhum	36 000 hectolitres
Vanille	15 tonnes
Essence de vétiver	13 tonnes
Géranium	45 tonnes
Tabac	85 tonnes

Cependant, si le nombre des navires de commerce est passé de 149 en 1956 à 374 en 1978, celui-ci tend à régresser du fait de l'augmentation de la taille et du port en lourd des nouveaux navires fréquentant la pointe des Galets. Ceci a nécessité, compte-tenu de l'évolution prévisible du trafic, la réalisation d'un nouveau port dans la baie de la Possession plus adapté au contexte international. Le trafic portuaire subira alors de nombreuses modifications:

- l'actuel port restera un port de pêche et sera réservé aux petits navires ainsi qu'à la marine nationale et à la plaisance;
- le port de la baie de la Possession sera destiné à recevoir les pétroliers, les porte-conteneurs et les vraquiers.

## RESSOURCES BIOLOGIQUES

Les surfaces cultivables représentent 26 à 30 pourcent de la superficie totale (250 000 ha) et 60 pourcent sont occupées par la canne à sucre, et la zone littorale est presque exclusivement consacrée à cette culture avec bien entendu celle des produits maraîchers, fruitiers et la vanille. Il faut cependant reconnaître que ces superficies ont légèrement diminué du fait de l'urbanisation accélérée des villes de St-Denis, St-Paul, le Port, St-Louis, St-Pierre et des zones balnéaires particulièrement sur la côte ouest. L'élevage est presque totalement implanté dans les hauts de la Réunion où se trouve un maximum d'espaces verts et de prairies.

## PECHES

Bien que possédant une zone économique maritime de 312 360 kilomètres, l'activité des pêches maritimes réunionnaises est rendue difficile par suite de facteurs naturels défavorables liés à la configuration de la côte de l'île, à l'absence du plateau continental, à l'éloignement des bancs de pêches exploitables et à la relative pauvreté des eaux tropicales de l'Océan Indien.

Confrontés à ces difficultés, les professionnels doivent également faire face à des problèmes d'accès à la ressource, résultant de décisions politiques ainsi qu'à des charges importantes pour le financement de leur outil de travail notamment pour la pêche hauturière, secteur dans lequel les investissements sont particulièrement lourds.

En 1982, le nombre d'inscrits maritimes était d'environ 700, nombre relativement stable depuis 1978 (634 en 1981) dont 430 pêcheurs-artisans pratiquant la pêche côtière, une cinquantaine pratiquant la pêche artisanale au large, une centaine pratiquant la pêche au large.

La consommation réunionnaise est une des plus faibles de l'Océan Indien située entre 9 et 10 kg par habitant et par an. Le poisson de la pêche côtière est réservé à une clientèle ayant un certain pouvoir d'achat car c'est un poisson d'excellente qualité mais cher. Le coût de ce poisson s'explique par la demande, supérieure à l'offre, ainsi que par les circuits de distribution (accapareurs et parfois sous-accapareurs). Le réunionnais consomme de préférence du poisson frais, l'habitant pauvre mange du poisson importé en salé, séché ou fumé, la population appréciant moyennement le poisson congelé.

Les circuits de commercialisation mis en place varient en fonction du type de pêche pratiquée et de la présentation du poisson.

Pour la pêche artisanale. Le mareyeur ou accapareur réunionnais paye au débarquement la pêche des pirogues et vend au marché les poissons débarqués. Chaque accapareur a plusieurs barques dont les apports lui sont réservés en priorité. Cette situation accroît la dépendance du pêcheur vis à vis de l'accapareur. Cette pêche représentait 679,2 tonnes en 1978, 626,5 tonnes en 1979, 594,2 tonnes en 1980 pour 318 bateaux occupant 430 marins.

La pêche au large n'a débuté qu'en novembre 1975, passant de 70,5 tonnes à 122,5 tonnes. Elle comptait à cette date deux bateaux pour 45 marins. La SOCOPECHE (Société Coopérative des marins-Pêcheurs de la Réunion) puis l'Association des

pêcheurs artisans de la Réunion exploitent ces deux unités afin de ravitailler la Réunion en poissons frais et qui opèrent essentiellement sur le banc Sadar situé au nord-ouest de l'île Maurice.

La grande pêche est composée de la pêche lointaine tropicale et de la pêche australe à partir de la Réunion. Elle a rapporté en 1980 avec trois bateaux et 126 pêcheurs, 851,2 tonnes, la capture des langoustes représentant à elles seules la moitié de cette valeur. Depuis 1972, trois sociétés exploitent les fonds des terres australes et antarctiques françaises, la SAPMER, l'Armement des Mascareignes et la C.I.A.P. (Compagnie Industrielle d'Armement et de Pêche).

Pour la pêche tropicale qui s'effectue sur les bancs de Saya de Malha et de Nazarette, elle se compose à ce jour de deux navires appartenant à la C.I.A.P. et l'Armement des Mascareignes.

Pour la pêche au large, le poisson est réfrigéré tandis que pour la pêche lointaine, il est congelé et stocké en palette dans les entrepôts frigorifiques de la Chambre de Commerce et d'Industrie. Ces produits sont en vente chez la plupart des détaillants en alimentation qui possèdent des congélateurs. Un problème subsiste cependant: le développement incontrôlé de la pêche sous-marine. Il est difficile d'interdire cette activité bien que les stocks de langoustes et de crevettes aient été pillés parfois. Si cette forme de pêche n'est pas contrôlable par l'Administration, il faut souligner qu'il semble anormal d'interdire pêche et cueillette sur les récifs frangeants qui ne mettent pas en danger le potentiel alors que le stock de langoustes pourrait être utilisé pour développer l'aquaculture.

#### Aquaculture

Cette "expérience" a démarré en 1978 à partir d'une étude scientifique sur la tortue franche ou tortue verte qui utilise comme sites de ponte les îles de Tromelin et d'Europa. La ferme CORAIL installée à la pointe des Châteaux à St-Leu, se consacre au grossissement de la tortue franche à partir de jeunes tortues prélevées sur les sites de ponte. Ces sites sont placés sous l'autorité administrative du Préfet de Région et protégés par l'Institut Scientifique et Technique des Pêches Maritimes. Cependant le développement de la Ferme est freiné par la convention de Washington sur la protection des espèces protégées.

#### TOURISME

Trois types de sites d'intérêt touristiques existent à la Réunion inégalement répartis sur le pourtour de l'île.

- sur la côte ouest et sud, les plages de St-Paul, Boucan-Canot, Roches-Noires, l'Hermitage, la Saline, St-Leu, Etang-Salé, St-Pierre, Grand-Anse;
- sur la côte est, les aires de nature et de loisirs, le Bocage, La Marine de Ste-Rose, l'Anse des Cascades;
- les points de vue promenades et sites touristiques ou culturels sont répartis sur l'ensemble de la côte.

Leur fréquentation est ancienne et traditionnelle pour les sites de natures, plus récentes pour les sites balnéaires. Des équipements spécifiques se sont développées surtout ces dernières années.

## Les hotels

La localisation des hôtels dans le département met en évidence leur inégale répartition par zone et par catégorie: 38 pourcent dans les centres urbains, 24 pourcent en zone littorale et 38 pourcent à l'intérieur de l'île. La répartition des hôtels en 1979 selon leur classement est la suivante:

Non homologué	11	38 %	65 chambres soit 10 %
Une étoile	3	10 %	37 chambres soit 5 %
Deux étoiles	9	31 %	170 chambres soit 26 %
Trois étoiles	5	17 %	256 chambres soit 39 %
Quatre étoiles	1	4 %	132 chambres soit 20 %

Au vu de ce tableau la Réunion apparaît comme la parente pauvre de ses soeurs voisines de l'Océan Indien et se classe loin derrière la Guadeloupe dans les départements d'Outre-Mer.

## Le camping

L'île dispose de quatre terrains de camping municipaux et trois privés sur le littoral ouest possédant un certain confort pour 300 emplacements environ.

## Maisons familiales de vacances

Ces établissements à caractère social reçoivent des familles ayant un niveau de vie modeste et bénéficiant de nombreuses aides. Deux maisons familiales représentant 115 lits se situent en bordure du littoral dans la commune de St-Paul.

## Les villages de vacances

Villages Vacances Familles (V.V.F.). Construits par la Caisse d'Allocations Familiales avec l'aide du Département, ces villages sont conçus sous forme de bungalows regroupant des studios avec ou sans restaurant. Il en existe deux sur le littoral ouest, un à St-Gilles, l'autre à St-Leu.

Un village de vacances est implanté en bordure du lagon de St-Gilles et peut mettre à la disposition de sa clientèle 140 lits.

## Les camps de vacances

Ils accueillent les classes de mer, des colonies de vacances et des familles. Ils sont au nombre de deux et proposent 370 lits.

La fréquentation de ces hébergements de tourisme est assurée par une clientèle provenant de trois sources: les touristes métropolitains (44 %), les touristes locaux (44 %), les touristes étrangers (7 %) et les gens d'affaires (5%). La durée moyenne de séjour en hôtel dans l'île serait de 4,3 jours avec une pointe durant les grandes vacances de la mi-décembre au mois de mars.

En 1978, les emplois dans l'hôtellerie et la restauration étaient, suivant les données de la Caisse Générale de la Sécurité Sociale, pour les hôtels de 230 et pour les restaurants de 402 personnes. Cependant, suivant la Chambre de Commerce et d'Industrie, seule, l'hôtellerie est peu pourvoyeuse d'emplois en raison de la taille des entreprises et de leur caractère familial. C'est à St-Gilles-les-bains que le tourisme a eu le plus d'effet sur le commerce. Ainsi sur 67 hôtels existant



en 1980, 48 ont été créés après 1975, y compris les restaurants; de même sur 21 services y compris les hôtels, 13 sont postérieurs à 1974. Etant une activité récente, le tourisme n'a encore donné lieu à aucune étude statistique approfondie. La mise en place d'un Centre Régional d'Observation du Tourisme permettra dans l'avenir de mieux apprécier les retombées économiques, en particulier celles du chiffre d'affaires régional induit par l'activité touristique toute entière.

Ce rapport a été réalisé grâce à la documentation effectuée pour la 'Région Réunion' en avril 1982 et mis à notre disposition par la Direction Départementale de l'Equipement.

Inclus avec le rapport mais malheureusement trop long pour être reproduit ici était le document suivant:

Aménagement et urbanisme de la Réunion (1982) Région Réunion: Schéma régional d'aménagement du littoral. 2 : Bibliographie.

SEYCHELLES NATIONAL REPORT : by E. Faure

BACKGROUND INFORMATION

The Seychelles archipelago is located in the western Indian Ocean between longitudes 46° and 56°S and latitudes 4° and 10°S. Seychelles is composed of about 100 islands scattered over 1,000,000 km<sup>2</sup> of the Indian Ocean. The total land area is 444 km<sup>2</sup> and total population is about 64,000. The islands fall into two categories: granitic and coralline. About 40 granitic islands lie within a 64 km radius of Mahé, the most important island. Characterized by a rugged topography, their mountains rise steeply from the coast to a 905 m elevation. Coastal plains, where most of the economic activities and industries take place, are narrow. The total island land area is approximately 214 km<sup>2</sup>. The 60 or more coralline islands are characteristically flat, rarely rising beyond 3-5 m above mean sea-level and are located in a 120-1,000 km range from Mahé. These coralline or outer islands are sparsely populated (about 500 people or 1 per cent of the total population). The main economic activity on the outer islands is copra production. Their only possible environmental problem would be saline intrusion through excessive underground fresh water extraction.

It should be emphasized, from the outset, that this report will deal mainly with the three largest islands, Mahé, Praslin and La Digue. They have the greatest population and most of the economic activity that may have an important environmental impact. It could even be argued that the report should deal solely with Mahé where almost 90 per cent of the population is concentrated. In fact, Seychelles is unique because all towns on the islands are not more than 2 km from the sea, which means that all human activity affects the coast and surrounding sea either directly or indirectly. The total length of the Seychelles coastline is approximately 600 km of which Mahé accounts for about 111 km. The Mahé coastline, which is mainly coral, can be divided into four zones that are typical of most of the Seychelles islands:

(a) Coastal plains or "Plateaux"

The coastal plains, locally known as "Plateaux", are flat, low-lying coastal areas made up of calcareous sand and soil derived from the debris of adjacent fringing reefs. The plateaux generally range between 1.6 - 3 m above sea-level and are situated at the head of nearly every bay around the coastline. They vary in width from narrow sand strips to areas of up to 1.2 km wide. The largest plateaux are found on Mahé's east coast at Anse aux Pins and Anse Royale. Others can be found on the west coast at Anse la Mouche, Anse Boileau, Grande Anse, Port Glaud and Beau Vallon (see map 1). Most of the plateaux contain saline or fresh water swamps connected to island rivers or streams, and to shoreline tidal channels. The plateaux on the granitic islands cover an area of about 40 km<sup>2</sup> or 20 per cent of the total area. The size of the plateaux on Mahé is approximately 13 km<sup>2</sup> or 10 per cent of its total area. Most of the hotels, business and government offices, industries and other economic activities are concentrated on this plateaux. It is important to stress the great role the coast plays in the country's economic development; for example, the main tourist attraction in the Seychelles is the beach and tourism contributes most of the foreign exchange. Mahé is 27 km long and about 11 km wide, its total area covering about 154 km<sup>2</sup>.

(b) Beaches and inshore lagoons

Data on the extent of beaches in three of the main islands are given below <sup>1/</sup>.

Island	Length of coastline		Length of beaches		Beach of coastline %
	km	%	km	%	
Mahé	111.3	66	31.4	53	28.2
Praslin	42.4	25	20.0	34	47.2
La Digue	14.5	7	8.0	13	55.2
TOTAL	168.2	100	59.4	100	130.6

The width of the beach varies from 3 - 6 m depending on the tides. Tidal variations are relatively small, ranging from 1.19 m (spring-tide) to 0.46 m (neap-tide).

Inshore lagoons are areas located between the beaches and fringing reefs. Their depth ranges from 0 - 4 m. Mud-flats are to be found at the mouths of the Rochon, Mamelles, Cascade and Anse Etoile rivers. True swamps are rare although fringing mangroves are found in numerous sheltered bays along the east and west coast. The largest mangrove swamp on Mahé is at Port Launay on the west coast and covers an area of some 3 - 5 ha. Generally, mangrove swamps exist in small patches rather than extensively.

(c) Coral Reefs

Fringing coral reefs are found near most of the islands, usually located 50 to 1,000 m from the shores. Their regular outline is explained by the smoothing effects of heavy surf. However, there is a continuous fringing reef in the Port Victoria area between North East Point and the airport (built on reclaimed land) which has different features from fringing reefs found in other parts of the Seychelles. The reef in question extends for nearly 10 km and is characterized by a highly sinuous and steep outer margin, and by the presence of deep pools, narrow boat channels penetrating almost to the shore, and outlying patch reefs. The irregular features of the reef are explained by the fact that it lies in a sheltered position and there is little water action to smooth it down. "The steepness of the reef margins may be accounted for by the lack of detritus and the sinuous nature of the margin is due to a lack of strong off-shore currents and the absence of the smoothing effect of heavy surf. In fact these reefs show many of the morphological features of lagoon reefs. The narrow boat/channels are in some cases connected to the mouth of rivers, as at Rochon, Mamelles and Cascade, and in these cases the channels are attributed to the inhibition of coral growth by muddy river-water" <sup>2/</sup>. The outflows of these three rivers are found on the east coast whereas Grand Anse, Anse Boileau and Mare Aux Cochons are on the west coast.

<sup>1/</sup> Source: Republic of Seychelles Tourism Plan, Vol. I, p. 86.

<sup>2/</sup> Baker, B.H.: Geology and Mineral Resources of the Seychelles Archipelago, p.14.

(d) Continental shelf

The Seychelles continental shelf begins where the coral reefs end and extends for an area of 48,000 km<sup>2</sup>. The shelf represents 5 per cent of the Exclusive Economic Zone (EEZ) and is less than 200 m. Most of the shelf is located in the north-east: the Mahé and Amirante plateaux and the Fortune Bank.

Land-based sources of pollution

The low level of industrial activity found in the Seychelles means that its surrounding marine environment is not heavily polluted. There are, however, localized pollution problems. Firstly, at La Retraite in the north of Mahé, 20 tonnes of solid waste are dumped daily into the sea. The waste is land-filled but there is a certain degree of marine pollution whose extent and ecological consequences have yet to be assessed.

Secondly, a furniture factory, located at Mont Fleuri on the east coast of Mahé, discharges into the ocean, four times annually, 20,000 litres of spent wood preservative liquor containing high levels of copper and arsenic substances. This may possibly have harmful effects on the coastal environment.

Thirdly, during housing construction, steep slope soils are often washed into the ocean by the rain, especially in the rainy season, causing siltation problems in the harbour and estuaries. This problem is further aggravated by poor agricultural practices, i.e. lack of adequate terracing.

Fourthly, during the construction of the airport and the port in 1969-1971 the surrounding reefs were damaged and partly destroyed by dredging. Recent evidence seems to indicate that the reef's ecosystem has recovered. The east coast is more densely populated than the west and, accordingly, is more polluted, especially from waste disposal.

Climate and current patterns

Two alternating trade winds determine the climate of the Seychelles. The strong, dry winds of the south-east monsoon blow steadily from May to October and average 10-12 knots. The north-west monsoon tends to be erratic, alternating between periods of calm and terrific squalls or torrential rains. It blows from December to March, leaving November and April as the transitional months.

The annual rainfall for Mahé varies according to location and elevation, with about 1,700 mm along the coast and reaching over 3,500 mm on the mountain peaks. 60 per cent of all rainfall occurs during the north-west monsoon. Temperatures average 27°C over the year and relative humidity is 45-80 per cent.

Seychelles is situated in the border zone between the equatorial current in the south and the equatorial counter-current in the north. The borderline moves throughout the year and has been located across the Mahé plateaux during the north-west monsoon in December and further south by the end of the monsoon period. During the south-east monsoon, the border is driven northwards to about 2°S. Between the equatorial current and counter-current there is a zone of turbulence with lateral and vertical mixing between and within these water masses.

Upwelling occurs in the southern and eastern edges of the Mahé plateaux. Upwelling has been indicated by the presence of cold sub-surface water, rich in nutrients and supporting plankton blooms.

Population directly depending on the coast and coastal waters for food, workplace

### Food

The coastal waters and the continental shelf constitute at present the main fishing grounds for local fishermen. Fish forms an important part of the local diet. Local marine fish landings are approximately 4,000-5,000 tonnes per annum. The per capita fish consumption for both locals and tourists is 82 kg per annum.

Apart from fish the whole population depends on certain vegetables, especially tomatoes, which are grown mainly on the coast. Owing to soil and climatic conditions, tomatoes grow well in the sandy coastal soils and approximately 150 tonnes are produced annually.

### Workplace

Almost all the hotels, transport facilities and other services are located on the coast, which means that more than 50 per cent of the registered employed labour force, i.e. 8,939 (of the total 17,875), work on the coast. There are 7,000 unregistered people, half of whom work. The total number of coastal workers, therefore, is probably more than 12,500; this includes 1,100 fishermen.

### Shelter

Although most of the people work on the coast, only about 20-30 per cent live there. This is because these areas have large coconut plantations. Pockets of high density housing are found on the east and west coast of Mahé in places such as Pointe Larue, Anse Aux Pins, Anse Royale, Anse Boileau and Port Launay. National Youth Service Villages at Port Launay, Cap Ternay and on Ste Anne Island, all on the coast, have a population of nearly 3,000. Thus, the total number of people living on the coast ranges between 16,000 and 20,000.

### Population growth

Population growth on the coast has not followed any pattern. In effect, two forces have been at play. Firstly, in the late 1960s and early 1970s, Government established housing estates at Anse Aux Pins and Corgat Estate for approximately 1,000 people. Secondly, housing was also erected for expatriates in areas such as Turtle Bay and Anse Aux Pins on the east coast, and Anse La Mouche on the west coast. Apart from such non-natural migratory factors there has been a tendency to build on sloping land, mainly because of the availability of land in the higher regions of Mahé.

Employment by sectors

Employment in tourism, fishing and government services is heavily concentrated on the coast.

Sectors	1977 Census	1982 Estimates	% working on coast Estimates
Agriculture	4,029	4,000	50
Fishing	835	1,100	100
Manufacturing	1,366	1,020	80
Water/electricity	197	917	50
Construction	4,244	2,663	40
Trade	1,353	1,207	60
Hotels	2,158	1,799	98
Restaurants	141	286	90
Tourism/aviation/other transport/communications	2,058	2,120	100
Finance & business services	457	820	100
Domestic services	2,595	2,500	50
Social services	1,602	3,390	60
Other services	1,928	2,100	-
International bodies not stated	279	260	-
TOTAL	23,339	24,182	

GNP and share of coastal activities

The primary economic activities on the coast are tourism and fisheries and they accounted for at least 20 per cent of GDP in 1980. Tourism was 16.6 per cent and fisheries 3-4 per cent. Details are shown below. Secondary activities, such as transport, government services, etc., increase the GDP to more than 50 per cent.

Gross Domestic Produce (1980) at current market prices  
in Rs. million (930) :

	percentage
Agriculture, forestry, fishing	7.1 %
Mining, manufacturing, construction	14.5 %
Tourism-related industries	16.6 %
Other transport and distribution	35.4 %
Government services	14.3 %
Finance and other services	12.1 %

(Source: National Development Plan 1982 - 1986, p.6)

### National infrastructure dealing with environmental issues

Government is fully aware that the main wealth of Seychelles lies in its marine resources. Moreover, since the islands are small, the need to preserve the fragile balance of the ecosystem between land- and sea-based activities is extremely important. Since 1925, Acts and Measures have been passed to protect marine resources. In 1969, the National Parks and Nature Conservancy Commission was set up to manage parks and to promote nature conservation. However, in the past fifteen years, a number of developments have resulted in the need for strict policies and control of all environment-related activities. In Seychelles there is competing demand for land for housing, agriculture, tourism and industries. The need to reclaim land and to protect coastal marine resources threatened by tourism development is fast becoming urgent.

Against this background, the Government created a body corporate in 1982, the Seychelles National Environment Commission, independent of Government, to formulate national policies and co-ordinate all environmental matters. The commission is chaired by the Minister for Planning and External Relations and is composed of nearly 15 members, all having a direct involvement in the environment. Policy execution is carried out by the Conservation Division of the Ministry of National Development. The Head of Conservation is the Secretary of the Commission, which means that decisions taken by the Commission are implemented effectively. However, the Commission and Conservation Division face two main problems, namely, insufficient financial resources and lack of trained manpower. The Commission's budget is derived from collection of entry fees to National Parks and the sale of cocos-de-mer. Approximately Rs. 800,000 are obtained from these sources. Funds are transferred to the Conservation Division to meet its annual expenditures incurred by salaries and maintenance of boats and transport facilities. The total annual running cost is in the order of Rs. 700,000. Because local resources are inadequate, plans have been drawn up to mobilize foreign assistance which include:

- recruitment of a full-time Environmental Co-ordinator;
- a study of the environmental impact of the construction of the east coast project (creation of fishing port, extension to commercial port, road between town and airport, land reclamation, etc.);
- setting up a modern refuse disposal system;
- construction of storm water sea discharge controls;
- improvement of the coastal strips, etc.

The manpower problem is closely related to a financial one. The latter inhibits an increase in human resources in environmental matters. In order to utilize effectively existing resources, the Commission is drawing up a strategy stating the country's priorities in environmental issues, with a view to allocating scarce manpower and financial resources accordingly.

### URBAN AND RURAL DEVELOPMENT

Victoria, the capital and only city in Seychelles, is the commercial and administrative centre of the island. In this section of the report it is referred to as Greater Victoria, which incorporates urban Victoria and proximate districts such as Mont Fleuri and Plaisance (see map 1).

Greater Victoria is located on the north-eastern side of Mahé and occupies 10 per cent of the total land area of Mahé, or 15 km<sup>2</sup>. This figure includes 23 ha of reclamation which was effected in 1970. Coral sand was dredged from the harbour and the new commercial port was built on reclaimed land. In order to prevent flooding, the coral fill was placed at a level of 1.8 m above mean sea-level. It should be noted that about 10 ha of the older portion of central Victoria lie as much as 0.7 m below the 1.8 m level and during periods of heavy rains some flooding occurs.

In 1977, 42 per cent of the island's population was found in Victoria which included 37 per cent of the total population of the islands. Approximately 24,000 people live in Victoria at present. These figures have not changed because most, if not all, recent housing construction has been implemented away from Victoria.

Migration into Victoria is minimal due to the size of Mahé. No place on Mahé is more than 15 km from Victoria so that commuting is easy, especially with regular bus transport systems. In fact, some 1,500 workers commute daily from Mahé to the city.

According to the 1977 census, 4,647 households and 23,012 people resided in Greater Victoria. The average household size is just under five. Shown below are the population growth of Greater Victoria and surrounding regions, and a projection to 1997.

Population of Seychelles by region 1960-1977; and projection 1997

Region	1960	1971	1977	1997
Greater Victoria	14800	20100	23500	35100
Mahé East	4300	5900	8200	9600
Mahé South	5300	6600	7500	12700
Mahé West	4200	5400	6400	9700
Mahé North	4900	7400	9000	13900
Praslin	3900	4200	4300	6400
La Digue	1800	2000	1900	2100
Other islands	2200	1300	1100	1600
TOTAL	41400	52900	61900	91100

(Source: Victoria Master Plan 1980 by C. Buchanan & Partners, pp. 13 & 14)

The projection made by the Master Plan report may be slightly exaggerated, for the population of Seychelles in 1982 was 64,410.

Land use

The general land use pattern in Victoria is as follows:

Land Use	Hectares
Urban/settlement areas	350
Central area - harbour & port	60
National park (land)	380
Other maintenance areas	620
TOTAL	1410

Estimates of residential density are difficult to make because residential boundaries are not clearly demarcated. Typically, there is a gradual build-up of density from peripheral areas to small pockets of concentrated development. In the Corgat Estate (Mont Fleuri) there are just over 200 persons or 40 dwellings per



Using a rough calculation, there is enough land within Greater Victoria for an additional 4,000-6,000 people. This area consists, in part, of relatively flat land to the north and south of present development, and in part of small infill sites among dwellings.

#### Public health facilities

Health facilities in Greater Victoria are well developed. The main hospital is located at Mont Fleuri and two clinics have recently been built, one at English River and one at Mont Fleuri. These clinics cater for out-patients and provide family planning advice and a child welfare service. Each clinic serves a population of 4,000-5,000 and are administered by district health teams with a doctor in charge.

It is planned to modernize the main hospital as a referral hospital starting in January 1984. There is also a plan to build, in the same year, a clinic at Les Mamelles. The existing and planned facilities can cope with a forecasted population of 35,000 for Greater Victoria by 1997.

#### Sanitation

##### Waste water disposal

There are three methods of waste water disposal in Greater Victoria. First, there is a piped municipal collection system with treatment in an aeration plant. This system serves 33 connections and copes with a population of 8,000. The second method is a system of pit latrines, serving 47 per cent of the population of 10,810 people. The third system is one of septic tanks, serving 44 per cent of the population or 10,120 people.

The last two systems pose serious health risks because waste water is sometimes discharged into road channels and watercourses, particularly in the central area. The cause of this discharge is due partly to a malfunctioning in the septic tanks and the leaking of aqua-privy effluent systems into impermeable rocky soils and high water table areas of the Old Town, and partly due to a system whereby all waste water other than that from flush toilets is allowed to discharge directly to open channels. Eventually, all this waste water runs into the sea thus causing pollution of the coast and surface waters.

In order to remedy the situation the Government is constructing and installing sewerage facilities that will connect the town centre, Victoria Hospital and areas north of Victoria to the existing sewerage treatment works on the New Port. Construction work is expected to start in 1985. By the time the project is completed more than half the population of Greater Victoria will have proper waste water disposal facilities, thus reducing the incidence of intestinal parasitic diseases on Mahé.

##### Water supply

Greater Victoria is well served by the public water supply system: 70 per cent of households have water taps and another 20 per cent use public stand-pipes. Daily consumption of water per head is 180 litres, a total of 4,140 m<sup>3</sup>/day (for 23,000 people).

### Extent of physical planning and social policy

There has been little overall planning in Victoria but the town has developed in a fairly neat pattern. The main concern for Greater Victor is the need to accommodate an increase in population while providing a clear structural framework within which the main urban functions and land uses can be integrated. The central area has urgent planning control problems in allocation of building sites, particularly in the absence of a plan showing how newly reclaimed areas can be integrated with the old centre.

There are plans to develop, in a balanced manner, the central area including the long pier (fishing port) and commercial port and the whole of the east coast corridor from Victoria to the airport. The intent is to achieve a balance between social needs (housing, education, health and community facilities) and industrial development. The Victoria Master Plan, produced in 1980, provides zoning recommendations and regulations for the central and commercial port areas; however, they have not yet been implemented.

#### Coastal ports (see map 2)

Victoria has two ports; a commercial port built on reclaimed land and an old fishing inter-island schooner port built on a land-filled foundation.

#### Commercial port

The present quay, sheltered by a protecting reef (see Background Information) is 215 m long and the water alongside 10.6 m deep. The port is served by conventional vessels although the number of container vessels is increasing. In 1980, about 20 per cent of the total imported general cargo was landed in containers.

The level of traffic passing through Port Victoria is, by international standards, relatively small (125 to 130,000 tonnes on average per annum). Since the port is located near several important shipping lanes, ships do not have to make wide, and therefore costly, diversions to reach Mahé. As a result, Seychelles is served by a significant number of shipping lines and receives a high frequency of vessel calls. In 1980, 30 calls were made by small and 67 by standard general cargo vessels, ten by oil tankers and seven by cement tankers.

#### Fishing port

Fishing is of strategic economic importance to Seychelles; fish is the main source of protein and in the future it could become a major export industry. There are three main categories of fishing vessels using the port:

- open boat fleet (6m - 9m): 50 - 65 boats;
- schooner fleet (10m - 18m): 40 - 45 schooners;
- purse seiner and long liner fleet (45m - 70m): 4 seiners and 1 long liner.

At present, the purse seiner fleet is foreign-owned. The total annual tonnage of fish landed at the fishing port varies from 1,700 to 2,500.

## COASTAL INDUSTRIAL DEVELOPMENT

Seychelles has a few industries which include a brewery, a paint, tyre retreading and plastics factory, and a small steel workshop. They are located in the Le Rocher industrial zone on the east coast of Mahé. Most of the material used is imported and finished products are sold locally. According to a 1980 survey by Camp Dresser McKee all the industries were using septic tanks for toilet wastes and process waters were handled adequately enough to prevent any apparent public health hazards (see annex). The brewery and other industries in the area dispose of their solid wastes at two coastal land-fills. There is little evidence of pollution. The industries in the area provide employment to approximately 320 people and Seychelles Breweries, the largest employer, employs about 140 people. British Motors, the brewery, paint factory and SayBake bakery (now burnt) employ the remaining 180.

## COASTAL AND INLAND HYDROPOWER AND WATER WORKS

Most of the treated water system is concentrated in the north-eastern part of Mahé. Details of the supply system are shown in map 3. The Le Niol, Cascade and Rochon treatment works are supplied directly from river intakes (i.e. run-of-the-river abstractions). The La Gogue earth dam has a small catchment area and is filled and is filled by gravity transfer of surplus flow from Rochon.

In general, the construction of dams on the Rochon, Le Niol and Cascade rivers has not had any adverse effects on the coast and coastal waters. During the rainy season, lateritic soils are washed down the coast by gushing streams and rivers. However, no study has yet been done on siltation in the dams and at the mouth of rivers, but it poses a problem during the rainy season.

Siltation could become a serious environmental problem when the fishing port and new port are extended because this will involve dredging operations. Dilution of waste and effluent flowing into the rivers increases during the rainy season and decreases during the dry. Again, no studies have been carried out on this subject. Generally, water abstractions from rivers pose few problems for the coast.

Potentially serious problems may be encountered when abstracting on the coastal plains of the granitic and outer islands. Approximate estimates of fresh ground water, stored in the coral-sand aquifers on the coastal plains, are shown below:

Aquifer locality	Approximate volume of stored fresh ground water (kl)
Grand Anse/Barbarons	98 000
Anse Royale	62 000
Anse Boileau	58 000
Anse à La Mouche	55 000
Reef Estate	53 000
Anse Forbans	40 000
Baie Lazare	33 000
Turtle Bay	30 000
Anse Intendance	28 000
Mahé Beach	20 000

Basically, the formation on the granitic and outer islands consists of a layer of fresh water overlying saline water. Fresh water is supplied by rainfall and streams. On the outer islands there are no streams and the recharge is entirely by rainfall. Ground water levels are also affected by tide movements. Therefore, in extracting ground water, extreme care must be taken not to overpump the fresh water aquifer because there is a danger of saline intrusion. Detailed studies are required on ground water resources and the degree of abstraction that will have no harmful ecological effects. Preliminary studies indicate that in order to prevent saline intrusion, pumping should not exceed two litres per second. Also, wells should not be deeper than four metres.

At present there is little irrigation on the granitic coast and outer islands, but plans are being drawn up for intensive maize cultivation on the islands. It is vital that careful monitoring of the ground water level take place in order to indicate the danger of saline intrusion. Wells should be dug far apart to prevent such intrusion. On La Digue the population is dependent on ground water and there is an urgent need to ensure that no septic tank leakages enter the fresh water aquifer.

## TRANSPORT

The two forms of coastal transport in Seychelles are by land and by sea.

### a) Land transport:

Most of the existing roads have been built along the coast where the terrain is flat. The cost of building roads on the steep slopes of the granitic islands is prohibitive. People are transported by cars and buses and cargo is carted in commercial vehicles which consist of small pick-ups and lorries. These do not exceed five tons. Traffic is heavily concentrated on the east coast of Mahé because most of the economic activities and human settlements are found there. A breakdown of the methods of transport is shown below:

Vehicle type	
Public transport buses	36 %
Private cars	34 %
Commercial pick-ups and lorries	20 %
Taxis	5 %
Other buses	5 %
TOTAL	100 %

In 1980 there were about 3,691 cars and taxis on the road, 181 buses, 898 commercial vehicles and 210 other transport. It is estimated that there are 85 vehicles per 1,000 people. Details on the internal transport of goods are not available; however, it is worth noting that because the roads are narrow (5-6 m) and their foundations are not very solid, the size of lorries is restricted to no more than ten tonnes.

### b) Sea/maritime transport:

Three distinct types of maritime transport can be identified and these are:

#### i) International trade

Goods are imported and exported through the commercial port located in Victoria. Seychelles has no international shipping vessels and all its trade is handled by foreign vessels. Details on traffic in the commercial port are given below.

	(Figures in thousands of tonnes)				
	1971	1975	1978	1979	1980
Imports General cargo	19.7	21.5	32.1	39.3	45.3
Bulk cement	21.1	13.4	13.8	11.0	17.8
Bulk oil	19.3	42.1	67.3	78.4	55.7
Sub-total	60.1	77.0	113.2	128.7	118.8
Exports					
General cargo	5.1	6.9	6.2	6.4	7.5
<b>TOTAL</b>	<b>65.1</b>	<b>83.9</b>	<b>119.4</b>	<b>135.1</b>	<b>126.3</b>

(Source: Port records)

The structure of general cargo imports for 1975 and 1979 is provided below:

	Per cent	
	1975	1979
Food beverages and tobacco	37.1	24.8
Chemicals	5.9	5.5
Textile and clothing	6.5	7.2
Other manufactured goods	23.9	22.8
Machinery and transport equipment	24.2	38.2
Other	2.4	1.5
<b>TOTAL</b>	<b>100.0</b>	<b>100.0</b>

(Source: Trade Records, 1979)

In relation to exports, copra accounts for slightly more than 50 per cent, with cinnamon and fish comprising the remainder.

#### ii) Inter-island transport

People and goods are transported between Mahé, Praslin and La Digue by privately-owned, inter-island schooners. Praslin and La Digue are located between 30-40 km from Mahé and are classified as inner-islands (to distinguish them from the outer-islands), and about 14 per cent of the population live on these. The schooners serving Praslin and La Digue are powered by sail and diesel engines. Their overall length is between 15-20 m and they carry approximately 20 tonnes of cargo and 45 passengers per trip. For safety reasons, the Port authorities exert control on the number of people and amount of cargo transported. The inter-islands schooners use the fishing port where the port quay is reserved for them.

#### iii) Outer-island transport

The outer-islands are located between 120 and 1,000 km from Mahé and transport by sea and air is costly. At present two vessels serve these islands, one having a cargo capacity of 50 tonnes and the other of 250 tonnes. The cargo from the outer islands consists mainly of copra, salted fish and meat. The population of the outer islands is about 500.

### Impact of transport on ecosystems

The construction of the commercial port and airport in the late 1960s and early 1970s had a severe impact on the region's coral area. Siltation as a result of dredging killed much of the coral. Damage to coral is also caused by careless anchoring of boats, schooners and ships on shallow patch reefs at low tide.

Plans to enlarge and modernize the commercial and fishing ports are shown in maps 4 and 5. Development of the fishing port is to take place in phases with phase I starting in 1985. This will involve 140 m of quay construction at 3.0 to 5.0 m depths. Onshore facilities, including an ice plant (capacity of 10 tonnes per day), a processing plant (8 tonnes capacity per day), additional cold stores (600 tonnes capacity), workshops and offices are also planned for phase I. Execution of phases II-III will depend on the success achieved in the first phase. With respect to the commercial port there are plans to extend the deep water quay by an additional 180 m thus providing two full berths. The dredged depth will be 10.66 m below chart datum alongside the berth. Space for a cargo shed and open storage, covering an area of about 25,000 m<sup>2</sup> is to be provided. The construction of these commercial and fishing ports will involve substantial dredging, and the coral reefs in the area, which have a thickness of 200-400 m, will be affected by siltation. Prior to and during construction, expert advice will be sought in order to minimize environmental problems.

### EXPLOITATION OF TERRESTRIAL BIOLOGICAL RESOURCES

There are two main agricultural activities on the granitic coastal plateaux and on the outer islands and these are:

- collection of coconuts and their transformation into copra, and
- vegetable production by small farmers or "blockers" on Mahé and Praslin.

Copra is one of the country's major exports. Details of the amount and value exported are given in table 1. Copra production has declined on the central granitic islands; its share of total production has fallen from about two thirds 10 years ago to less than half today. The main reasons are increasing pressure of competing needs on plateau lands, and the high labour costs of manuring and harvesting coconuts on the steep hillsides of the granitic islands. Moreover, Seychelles faces competition from other producers although it has a comparative advantage for the cup copra which commands a premium. Coconut trees are old; plans to replace them little by little with hybrids are being continuously implemented.

The second agricultural activity is vegetable production by "blockers" or small farmers and three State farms on Mahé and Praslin. In 1978 about 930 tonnes of vegetables valued at Rs. 3,380,000 were produced on Mahé for local consumption. Coastal farms accounted for approximately half of this production.

There are approximately 62 small farmers on the Praslin and 40 on the Mahé coasts. Total employment on coconut plantations, State farms and small farms is about 2,000. According to rough estimates, Seychelles uses approximately 6 tonnes of pesticides and herbicides per annum and 150 tonnes of single and complex fertilizers.

Table 1

Resources	1970	1971	1972	1973	1974	1975	1976	1977	1978	1979	1980
	Volume (tonnes)										
Copra	4 416	3 490	3 477	3 337	3 057	2 860	2 748	2 918	2 953	3 439	3 200
Cinnamon	1 306	1 277	1 975	1 630	1 448	1 085	1 153	799	610	483	577
Frozen fish	-	-	-	-	154	83	436	430	539	806	662
	Value (R'000) - Current Prices										
Copra	5 075	3 574	2 346	4 657	9 932	7 299	8 817	14 503	16 157	19 924	16 979
Cinnamon	3 767	3 332	5 938	7 208	7 047	3 629	3 664	3 311	1 895	1 782	2 310
Frozen fish	-	-	-	-	466	513	3 354	3 161	3 550	6 095	9 623

(Source: An Agricultural Strategy for Food Security, p.5)

FISHERIES

Data for the period 1975 - 1979 indicated increasing fish landings until 1978. From 1979 to 1981 the quantities of landed fish decreased; in 1978, 5,400 tonnes of fish were landed whereas in 1980 the amount was 3,900 tonnes. Total landings in 1982 and 1983 could well exceed 8,000 tonnes per annum as a result of tuna purse seining by four French vessels. In fact, between November 1982 and June 1983, the four seiners caught over 6,000 tonnes of tuna on the edge of the Mahé plateaux and in the ocean. A breakdown of landings in Seychelles by dominant species is given below.

Species	1975	1976	1977 (tonnes)	1978	1979	% of Total	Location and method of catch
Bonito, tuna and shark (pelagic)	460	410	330	460	500	8.7	Continental shelf and edge 35 - 100 m: handlining
Caranagues, Lutjanus spp. Epinephelus spp. Lethrinus nebulosus & others (demersal fish)	2,300	2,400	2,350	3,540	3,160	60.7	Mahé plateaux 20 - 100 m: handlining
Siganus abhortani, Cacatois & Rouget (demersal fish)	690	950	1,720	1,100	746	23.9	Inshore lagoons: areas with coral reefs less than 6 m: trapping
Rastrelliger kanagurta i.e. Indian mackerel (pelagic fish)	500	250	200	300	450	6.4	Inshore lagoons and beaches: gill nets and beach seines
Octopus and lobster	-	-	-	-	62	0.3	Inshore lagoons
TOTAL	3,950	4,010	4,600	5,400	4,908	100.0	

(Source: Seychelles Fisheries Feasibility Study 1982 p.122)

In 1977, 3.6 per cent of the total working population was engaged in fishing activities. By 1980/81 the percentage had increased to 4.5. At present, there are approximately 1,100 - 1,300 fishermen working full time and part time. The 1977 census, together with recent studies, indicate that the fishing sector has an ageing manpower base; in 1977 it was found that only 31 per cent of those engaged in fishing were between the ages of 15 - 29; this age group makes up 46 per cent of the entire working population. Some 50 per cent of all fishermen are self-employed. However, in 1981 a parastatal fishing company, FIDECO, was established which employs about 100 fishermen.



At present, most of the fishing is done by artisanal methods. The only type of industrial fishing, carried out by a national boat, is tuna long lining which employs 23 local fishermen who are being trained by South Koreans. Future industrial fishing for export by the national fleet would consist mainly of catching tuna by using purse seiners, pole and line vessels and long-liners.

On the basis of recent studies, the maximum biological sustainable yield on the Mahé plateaux for demersal fish is between 6,500 tonnes and 10,000 tonnes per annum. As for tuna, which is migratory, the sustainable yield is 5,000 tonnes for yellowfin and 35,000 for skipjack in the Seychelles EEZ. For the time being, fishermen are using artisanal fishing methods which include handlining, trapping, gill netting, beach seining and some trawling. Handline fishing is the most common method and is practised from the near coastal waters to the edge of the Mahé and Amirante plateaux with depths ranging from 20 m to 100 m. Trapfishing is done near the coast in the inshore lagoons. Traps are made of bamboo and usually V-shaped. Beach seines are used in shallow waters near the beach to catch mackerel. Fishermen in general prefer to sell the fish themselves, directly to consumers but, since the advent of the marketing organization SeyCom, there is a greater tendency for them to sell their catch to the organization especially during the fertile north-west monsoon period. During the south-east monsoon season, fish are more scarce. Fish consumption in Seychelles is one of the highest in the world. Adult per capita consumption has been estimated at about 80-90 kg per annum, while for children under 15 it is 60-63 kg. About 4,000 - 5,000 tonnes of fish are consumed by the local population annually. The amount of fish exported has grown from 154 tonnes in 1974 to 806 tonnes in 1979.

Fish is more important in the local diet than beef or pork. Annual consumption of pork and processed pork is between 300 - 400 tonnes and for beef it is about 250 tonnes. Fish consumption is expected to increase further with the development of processed fish products. At present, processing facilities are limited; however, some 10 tonnes of smoked sailfish, kingfish and marlin are produced for local consumption as well as for export to France, the Federal Republic of Germany and La Réunion, the latter being the main fish export market. Fish sausages are being produced on a small scale and so far consumers have reacted favourably to them. About 100 tonnes of salted fish are produced and consumed in Seychelles annually. Apart from developing fish products, there are plans to build a silage plant for the production of animal feed. However, the setting up of a silage plant is dependent on the creation and expansion of a tuna export industry. Seychelles plans to start seasonal tuna fishing through a joint venture which is expected to become operational towards the end of 1983. Guts from tuna, together with other fish wastes could then become a reliable supply of raw materials for the silage plant. As mentioned earlier, apart from a long liner, Seychelles does not have an industrial fishing fleet. Presently, foreign vessels, especially Japanese and S. Korean long liners, are licensed to fish in the Seychelles EEZ.

In 1977 these vessels caught 15,000 tonnes of yellowfin and 9,000 tonnes of big eye. The creation of a tuna export industry in Seychelles would require strict quality control of fish. Today, the post-harvest unit of the Fisheries Division in the Ministry of National Development is responsible for issuing export licences and health certificates for export consignments. Tighter sanitary control and inspection are needed throughout the industry. Legislation should be enacted to provide for co-ordinated quality control and health inspection of premises and equipment. Fish for the domestic market should also be subjected to proper quality control.

MINERAL (INCLUDING OIL AND SAND) EXPLORATION AND EXPLOITATION

Guano

Seychelles has few mineral resources. The only one worth mentioning is guano which is the name given to nitrogenous and phosphatic deposits consisting mainly of bird droppings that have accumulated over a lengthy period to form a recognizable layer. Guano is found mainly on the flat coralline islands where it has been exploited since 1895. Guano was exported mainly to Mauritius where it was applied to the sugar-cane fields. Exploitation has ceased since 1982. The guano deposits are nearly depleted; in fact from 1895 until 1960 over 680,000 tonnes were exported. Data on the export of guano for the 1972 - 1980 period is shown below:

	y e a r s								
	1972	1973	1974	1975	1976	1977	1978	1979	1980
Quantity (in tonnes)	9,216	7,112	3,541	3,988	5,669	5,280	6,089	6,382	4,285
Value in R'000 (f.o.b)									
current prices	546	447	270	471	1,110	1,319	1,738	1,814	1,393

It should be noted that in 1980 3,200 tonnes of copra brought in Rs. 16,979,000 while 4,285 tonnes of guano fetched Rs. 1,393,000. The two outer islands which still have a sizeable deposit of guano are Assumption and Desnoeufts; the latter has to be discounted because large-scale guano extraction would result in the birds being driven away.

Sand

Since July 1982 the Government has enacted strict legal controls and quotas on sand extraction. Sand extraction can only be legally undertaken by obtaining a licence from the Lands Division of the Ministry of National Development. From July to December 1982, 13,000 tonnes of sand and 1,000 tonnes of gravel were extracted. It is forbidden to extract sand from beaches because experience has shown that beaches can disappear as a result. Government encourages extraction at river mouths and on the coastal plateaux a good distance from the beaches. The excavated area must be refilled with red earth or other organic materials.

Oil exploration

Seychelles started active offshore oil exploration in 1977 when three oil companies were awarded 46 blocks (each block = 685 sq km). Seismic surveys, together with ship-borne magnetic and gravity surveys, were conducted on the licensed areas during 1977 - 1979. In 1981, three wells were dug on the western shelf but no commercial hydrocarbons were found. The wells, however, provided valuable information which encouraged further exploration.

TOURISM

Tourism is the backbone of the Seychelles economy; it is the main foreign exchange earner and also provides direct and indirect employment to a large portion of the labour force. In addition, tourism generates revenue for the Government and tourism expenditure has a relatively high multiplier effect on the economy.

There are 2,680 beds available in hotels and guest-houses situated near the beaches. Some details on the existing accommodations is provided below:

Type of accommodation	1977	1978	1979	1980	1981
<b>Mahé</b>					
Hotels & self-catering					
guest-houses; and	1,395	1,465	1,780	1,800	1,870
private homes	n.a*	n.a*	280	340	370
<b>Other islands</b>					
Hotels & self-catering					
guest-houses; and	n.a*	n.a*	220	350	370
private homes	n.a*	n.a*	150	80	70
<b>Total</b>	<b>1,970</b>	<b>2,170</b>	<b>2,430</b>	<b>2,560</b>	<b>2,680</b>

(Source: B. Archer: The Economic Impact of Tourism in Seychelles. p.19)

\* n.a.= not available separately

In 1981 there were 21 hotels, 28 guest-houses, 22 private houses and 3 self-catering blocks. From 1970 to 1979 there was a rapid increase in the number of tourists visiting Seychelles. Since 1980, however, there has been a sharp decline. The table below shows the situation for the period 1970-82.

Year	Number of tourists	Change on previous year
1970	1,622	-
1971	3,175	1,553
1972	15,197	12,022
1973	19,464	1,267
1974	25,932	6,468
1975	37,321	11,389
1976	49,498	12,177
1977	54,490	4,992
1978	64,995	10,505
1979	78,852	13,857
1980	71,762	(- 7,090)
1981	60,425	(-11,337)
1982	47,280	(-13,145)

(Source: Republic of Seychelles Tourism Plan Vol.I p.9)

The average length of stay has varied between 11 nights in 1977 to 9 nights in 1980. It is expected that in 1983 and 1984 tourism should start to move upward because plans to attract more tourists are showing encouraging results and tourism is crucial to the country's balance of payments.

Seychelles has a large deficit in its visible trade, and tourism contributes to the reduction of this deficit. Tourism's contribution to export earnings is shown in the table below:

Year	Exports	Re-exports	Tourism revenue	Total	Tourism revenue as % of total
1976	17.9	39.7	135	192.6	70.1
1977	24.4	53.7	175	253.1	69.1
1978	24.7	71.4	209	305.1	68.5
1979	30.9	83.7	246	360.6	68.2

(Source: Republic of Seychelles Tourism Plan Vol.I p.28)

The 1980 balance of payments account below clearly shows the importance of tourism receipts.

	Rs million (1980)
Exports - domestic f.o.b	32
- re-exports	80
- Imports - c.i.f	-650
= Visible balance	-538
+ Tourism receipts	331
+ Other goods and services	- 44
= Current account balance	251
+ Government and private capital	298
= Overall balance	47

(Source: Seychelles' Fisheries Feasibility Study, Vol.I-NORPLAN, p. 54, 1982)

Tourism has an effect on the level of employment because visitor expenditure on accommodation, transport, meals, etc. gives rise to a demand for labour. In 1981, there were 3,240 people directly employed in hotels, restaurants and tourism-related activities within the transport and communications sector, representing about 20 per cent of all registered employees. This figure excludes jobs which are indirectly dependent on tourism; if they were included tourism would provide employment to over 7,000 people. It has been calculated that "on average the expenditure of 18.7 tourists created one direct job, but for every direct job an additional 1.38 secondary jobs were maintained elsewhere in the economy"<sup>3/</sup>.

<sup>3/</sup> B. Archer: Economic Impact of Tourism in Seychelles.

## CONCLUSIONS

Tourism and fisheries constitute the main growth industries of the Seychelles and their expansion and survival depend to a large extent on the preservation and enhancement of the marine environment. The Government is fully aware of the need to preserve and protect the fragile and life-sustaining ecosystem of our islands.

## REFERENCES

- An Agricultural Strategy for Food Security in Seychelles (1982).
- Archer, B. (1982) The Economic Impact of Tourism in Seychelles.
- Baker, B.H. Geology and Mineral Resources of the Seychelles Archipelago.
- Feasibility Study of a Port and Land Reclamation Project Vol.1-9 (1981).
- Geography of Seychelles (1978).
- Government of Seychelles Trade Report (1970-1981).
- Government of Seychelles (1982) Seychelles' Fisheries Feasibility Study Vols 1 & 2.
- Mahé Water Supply Vols. 2 & 3 (1979).
- Pre-investment Studies for Waste Water Disposal for Victoria, Seychelles Final Report (1980).
- Republic of Seychelles: Tourism Plan (1981).
- Salm, R.C. (1980) Conservation of Marine Resources in Seychelles.
- Seychelles 1977 Census Report.
- Seychelles National Development Plan (1982-1986).
- Seychelles Structure Plan (1975).

Annex

Industrial wastes survey

INTRODUCTION

On March 20-21, 1980 nine firms in the Le Rocher industrial zone were interviewed to find out how water is used within each plant and how the waste water is treated and disposed of. Streams, storm drains and the shoreline were also examined for indications of pollution. Two plants in the area were not considered: a vacant building next to the Tropicolor paint factory and a carpentry shop. The nine firms visited were:

- Seybrew, which makes lager beer, stout and soft drinks;
- the abattoir which slaughters pigs and cows for farmers, operated by the Department of Agriculture;
- Laiterie des Iles dairy, which reconstitutes powdered milk to make milk, yoghurt, cheese and butter, and also packages fruit juice;
- Tropicolor plant factory, which makes latex and oil-based paint;
- Seysteel, a steel fabricator;
- Seybake, a bakery;
- British Motors, an automobile dealer;
- Chelle Plastics, which makes plastic containers;
- U.W.E. Industries, which makes rolls of toilet paper and plastic cups.

Results of the interviews are described below, and a general assessment of pollution in the area is given in section 3.

INTERVIEWS

Seybrew Ltd. The plant occupies several large modern buildings adjacent to the East Coast Road (ECR) within 70m of the shore. The GVMPs indicates employment of 180. Water supply is untreated and un-metered, but a metered treated-water connection has very recently been installed. The Brewmaster indicated the following. Average demand is 250kl/d, of which 80 per cent from cleaning bottles and draining residue from beer tanks occurs between 7 a.m. and 3.30 p.m. Less than 10 per cent of the water goes into the final product consisting of Seybrew lager beer, Guinness stout and Seypearl soft drinks. Every two weeks a caustic soda solution (pH of 9) is used to clean the bottling machines, and the effluent is mixed with low pH beer residue prior to discharge. Yeast is recycled and various waste products from beer production are processed into cattle-feed.

Abattoir. Consists of a single small building and holding pens located up a steep driveway about 100m from the ECR, adjacent to a boulder - strewn and overgrown stream-bed. The manager, who doubles as the meat inspector, estimated that 110 pigs and 10 cows are slaughtered each week, with 40 pigs/day being the peak production. Water is used primarily in supplying the scalding tank where hair and bristles are scraped off, in hosing down the floors, and in cooking contaminated meat and protein scraps to make cattle-feed. This water discharges to two large septic tanks in series, then passes into the stream-bed through two 100mm pipes. There is no underground soakway, and apparently no regularly scheduled de-sludging of the septic tanks. Nevertheless the flow is small and there were no apparent odours from the stream-bed or where the stream crosses the ECR. Once a week the holding pens are cleaned; drainage is captured in two septic tanks in series. The primary waste disposal problem is that stomach contents and other unusable remains must be trucked to the Beau Vallon State Farm for burial; the manager feels that on-site incineration would be a more economical long-term solution.

Laiterie des Iles. The manager estimated that only one third of the water supplied goes into dairy products; the remainder is used in washing milk containers and hosing down floors and works surfaces. The dilute washing water is discharged into the same stream that received effluent from the abattoir.

Tropicolor. The plant is located across the stream from the abattoir. The manager indicated that most of the water consumed goes into making latex paint; washing water associated with one batch is recycled in producing the next batch of paint. All turpentine and solvents used in making oil-based paint are either recycled, or the residue sold to be mixed with bitumen for road surfacing. A small amount of washing water is disposed of in several small tanks, from which the water passes into soakaway pipes and thence into the stream. There was some indication of clogging either in the soakaway pipes or soil, but the quantity of water involved is very small.

Seysteel. None of the operations involved in steel fabrication of structural beams, tanks, fences, burglar bars and roofing require process water, and a septic tank treats toilet wastes.

Seybake. The manager indicated that two wastewater disposal systems are used: a septic tank for domestic wastes, and a waste pit described as a "large 20ft hole filled with chunks of coral and rock" to receive scraps of dough and washing water. Water consumption is 5.8 kl/d, and most of waste water is from cleaning floors; baking pans and trays are scrapped clean rather than scrubbed. The septic tank causes problems after rains when ground water is high, and the second system has become clogged up. The bakery is adjacent to the ECR, and a trickle of malodorous waste water runs into the drainage ditch along the road.

British Motors. The manager indicated that grease and oil from servicing cars are trapped in a "petrol interceptor", where they are skimmed off from washing water and sold for spraying on to dirt roads.

Chelle Plastics Ltd. Water use consists only of cooling water, which is recycled to reduce consumption.

U.W.E. Enterprises. The plant was idle at the time of the visit. The man in charge stated that water was not used in rolling toilet paper and making plastic cups.

## ENVIRONMENTAL CONDITIONS

The Le Rocher industrial zone is on the landward side of the East Coast Road, with a narrow stretch of land between the road and the sea. The coral reef lies about 1,000m offshore at this point, and much of the shallow coral sand beach behind the reef is exposed at low tide. Two landfills are in operation, one in front of Seybrew where about 1 ha of land behind sea walls is being reclaimed using broken glass bottles and refuse from the brewery, and the second near British Motors where a boulder-strewn area is being filled in to form a parking lot.

Surveys of the area of various times indicated that to date the industries in the industrial zone have not caused severe degradation of the environment. Within the zone itself, the leachate from the bakery's clogged waste pit and the latex paint waste water at the paint factory were the only obvious signs of pollution. Along the shore there are small amounts of scum and the water is turbid. At low tide short, stocky, aquatic plants can be seen growing on the sand, possibly resulting from the nutrients in the industrial waste streams. Strong domestic sewage in a roadside ditch near Seybrew was found to be from housing along a small stream north of the plant site.







MAP 2

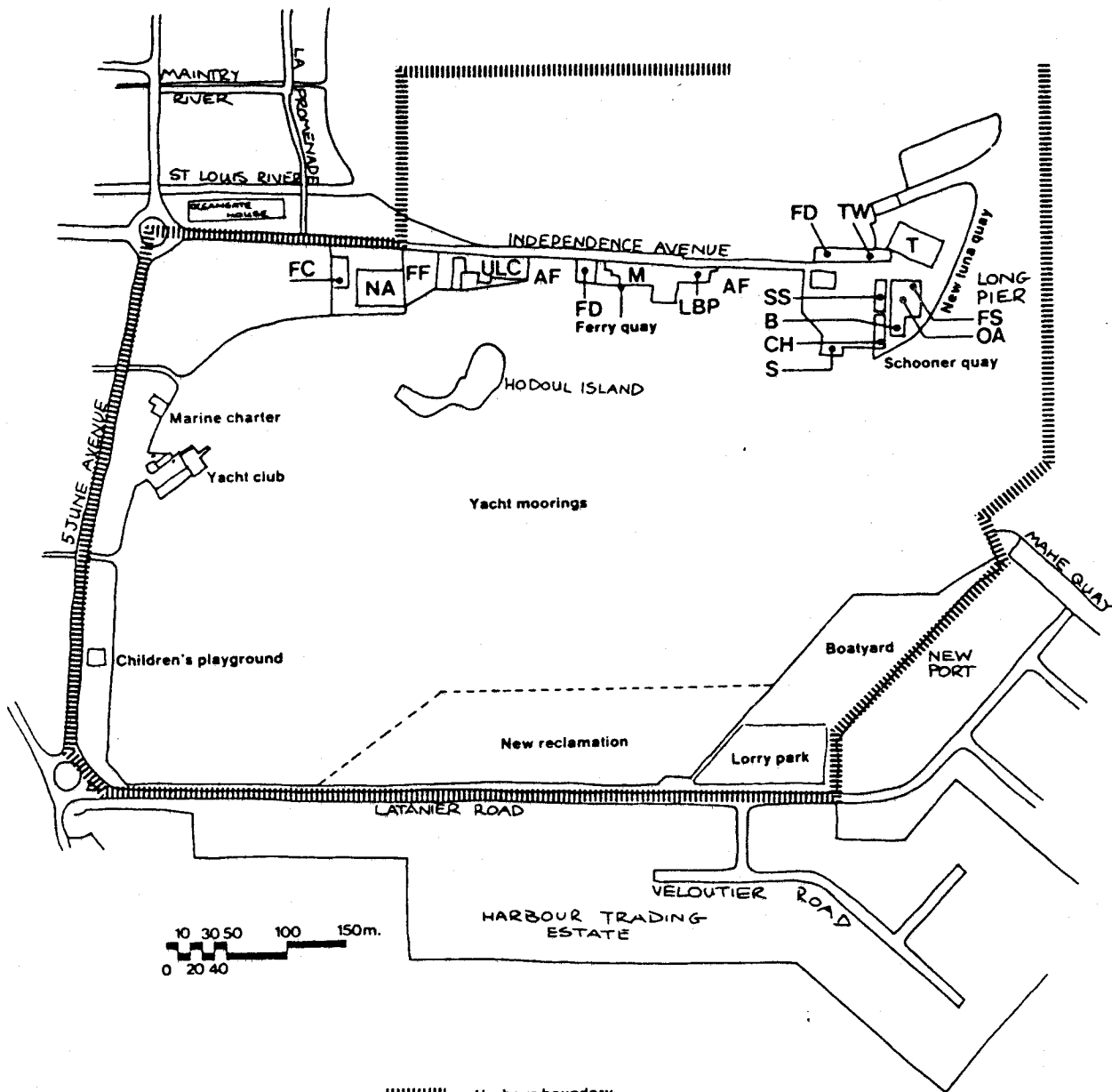

----- Harbour boundary

- |     |                              |     |                                   |
|-----|------------------------------|-----|-----------------------------------|
| AF  | Artisan fishing fleet        | M   | Government maintenance workshop   |
| B   | Boxing club                  | NA  | New agricultural requisites store |
| CH  | Old customs house            | OA  | Old agricultural requisites store |
| FC  | Farmers cooperative          | S   | Slipway                           |
| FD  | Fisheries division offices   | SS  | Storage shed                      |
| FF  | Fish freezer and cold stores | T   | New tuna cold store               |
| FS  | Fire station                 | TW  | Tradewind fisheries               |
| LBP | Le Bon Poisson               | ULC | Old union lighterage buildings    |

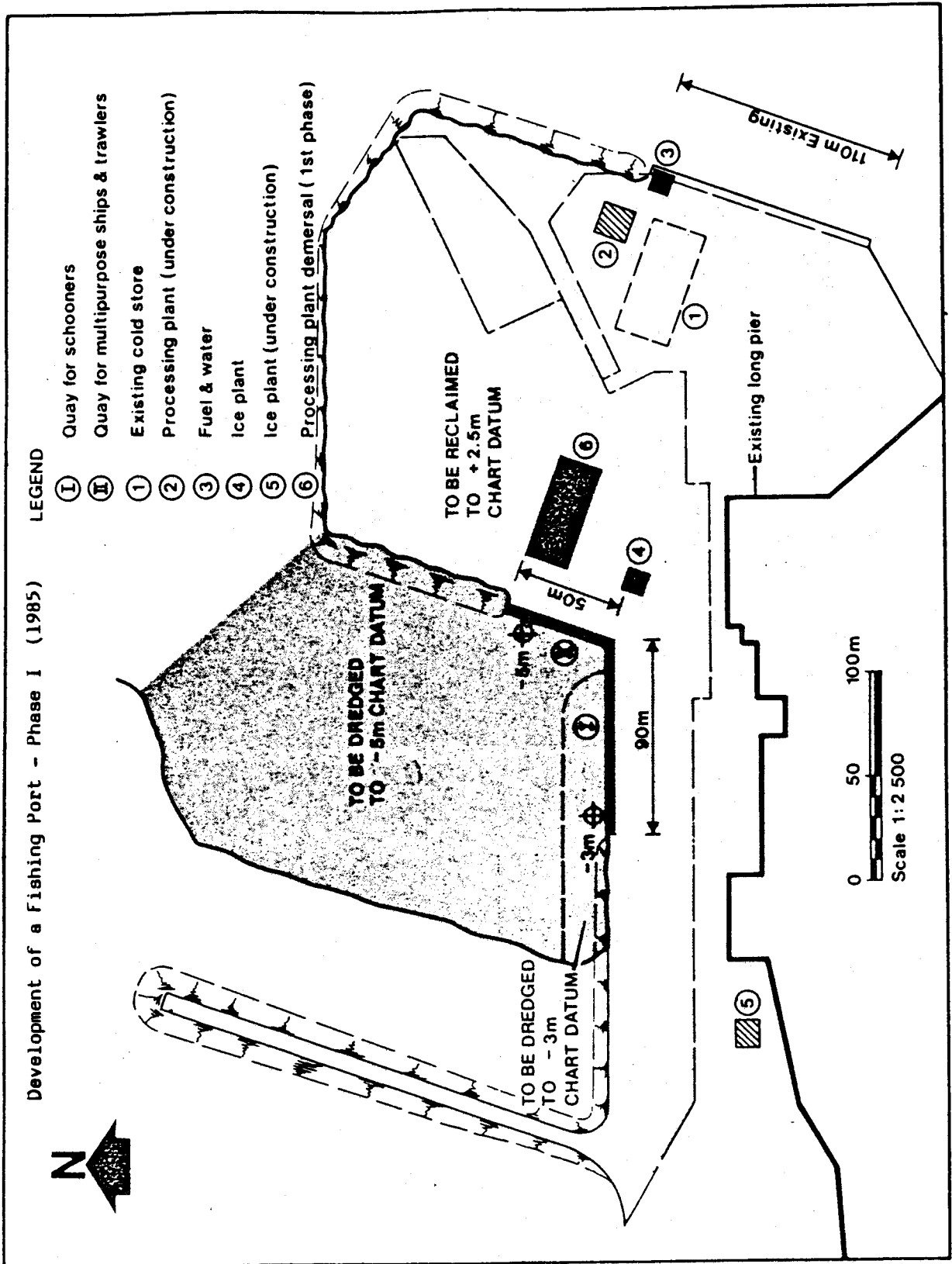

MAP 3

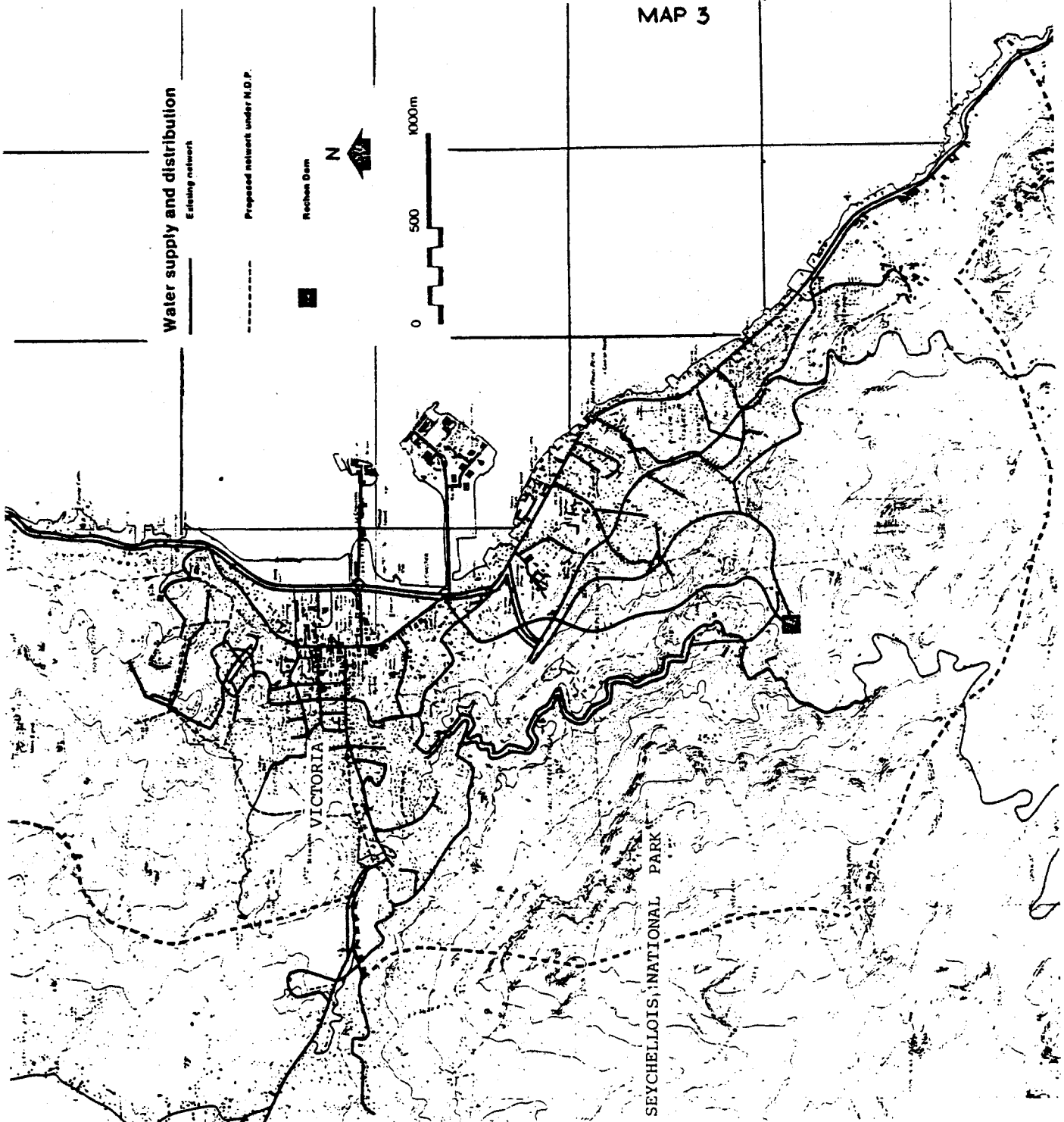

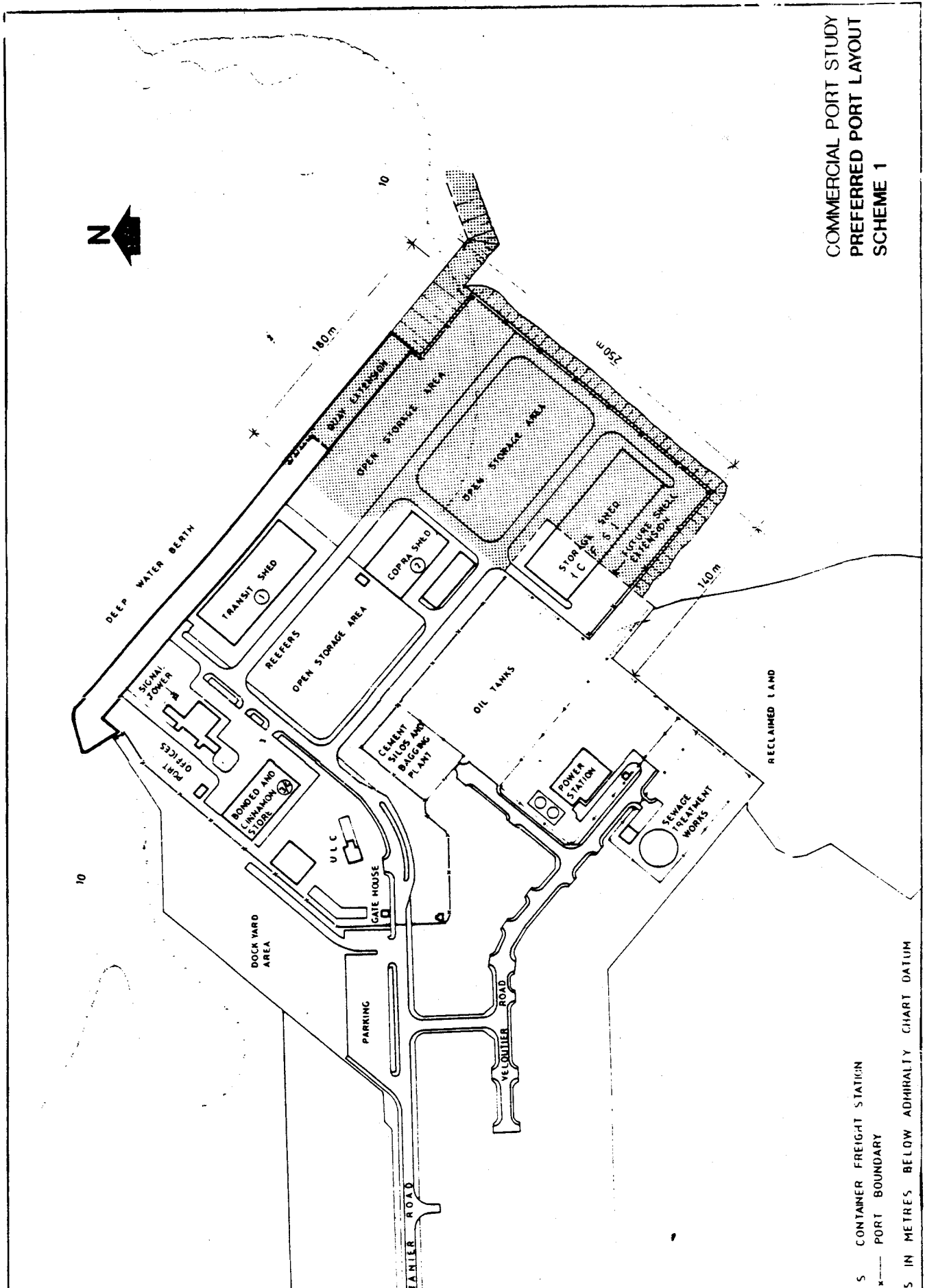

COMMERCIAL PORT STUDY  
PREFERRED PORT LAYOUT  
SCHEME 1

S CONTAINER FREIGHT STATION  
X--- PORT BOUNDARY

S IN METRES BELOW ADMIRALTY CHART DATUM

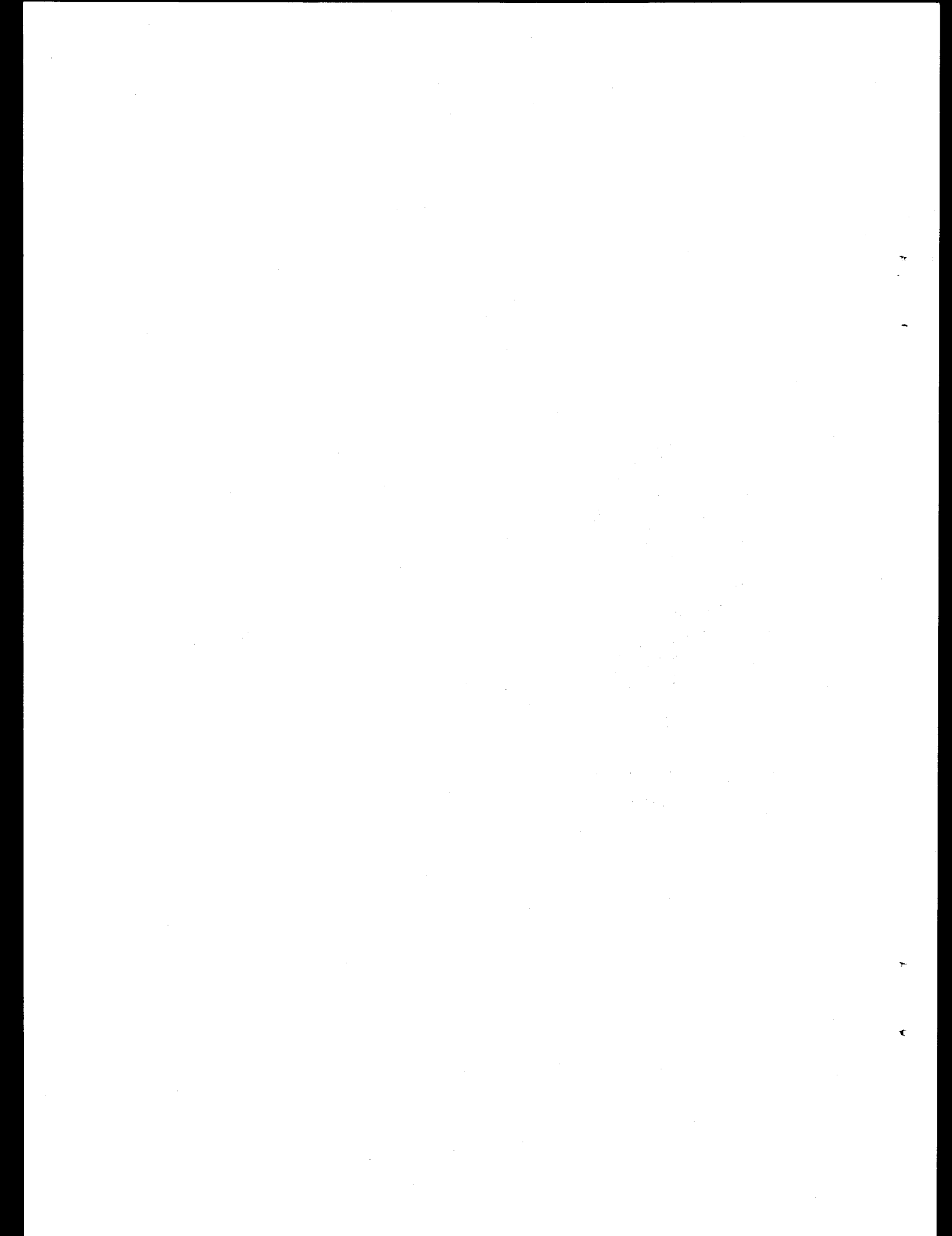

RAPPORT NATIONAL COMORIEN : par M.A. Halidi

DONNEES DE BASE

Situation géographique

L'Archipel des Comores est situé à l'est du continent africain à 250 km de la côte du Mozambique et à 350 km au nord-ouest de Madagascar, c'est à dire dans la partie septentrionale du Canal de Mozambique. Sa position est la suivante: latitude de 13°4'S à 11°20'S, et longitude de 43°03'E à 45°16'E. Il comprend quatre îles: Grande-Comore, Anjouan, Mohéli et Mayotte. Chaque île est éloignée de 30 à 60 milles l'une de l'autre. L'île de Mayotte, bien que considérée comme faisant partie de la République Fédérale Islamique, est sous administration française.

L'Archipel est situé en zone tropicale. Le plateau continental est étroit sauf à Mayotte où il atteint de 5 à 16 km créant parfaitement un lagon relié cependant à la haute mer par de vastes passes. En fait, l'Archipel est situé sur un seuil orienté est-ouest compris entre deux fosses, celle du nord de plus de 4 000 m et celle du sud de 3 500 m. La nature des plateaux continentaux, bien que toutes les îles ne se rattachent pas au type corallien de l'atoll, fait qu'elles présentent en général sur leurs côtes des formations madrépodiques très accidentées.

Les fonds sont coralliens et volcaniques et bordent les côtes des îles. Autour de Mayotte, le récif barrière présente des pentes de 15 à 30 pourcent entre 100 et 2 000 m au nord-ouest, les fonds coralliens formant cependant une plat-forme sous-marine à l'isobathe inférieure à 50 m et large d'une dizaine de kilomètres. A Anjouan, au delà des récifs frangeants, la situation est comparable à Mayotte. Mohéli, au-delà de la plate-forme sous-marine corallienne large de 5 à 8 milles, présente des pentes de 20 à 43 pourcent. Enfin, autour de la Grande-Comore les pentes sont elles aussi très accidentées.

Un régime de vents fort et complexe qui, à partir du régime général suivant: mai-octobre: alizé sud/sud-est vers nord/nord-ouest, et octobre-mai: alizé nord/nord-est vers sud/sud-ouest, voit apparaître des vents locaux (Koussi, Niombeni, Marebou, Motoulaf, Kascazi, Nohibou) qui, outre les cyclones tropicaux comme celui de janvier 1983, "ELINA", sont tous relativement forts, généralement de force 3-4 et souvent jusqu'à 5-6.

La circulation des eaux superficielles est dominée par les deux moussons. La mousson du sud-ouest apparaît à une certaine distance des côtes africaines mais son axe est à l'équateur au nord de Madagascar. Le courant sud-équatorial se dirige vers le nord entraînant de l'eau à l'est du Canal de Mozambique. Une zone de divergence localisée à la côte apparaît avec la mousson du nord-est. Ici c'est un axe de contre-courant équatorial se situant au nord où se tient un autre courant équatorial. Ce système très complexe, se trouvant dans l'hémisphère sud où les masses d'eau sont soumises à un grand mouvement giratoire s'effectuant dans le sens contraire des aiguilles d'une montre, conduit à la création de zones de convergence, de divergence et d'upwelling.

Le long de la côte est africaine la branche nord du courant sud-équatorial se joint au courant de la côte est africaine, partant au sud le long du bord ouest du canal de Mozambique. Par contre, le long de la côte est de Madagascar, il se forme une branche sud du courant sud-équatorial qui part au sud, contourne le sud de l'île et rejoint la côte africaine pour former le courant des aiguilles. Il en résulte deux cellules anti-cycloniques principales, l'une au nord autour des Comores avec Mayotte comme centre, l'autre au sud occupant le Canal de Mozambique. Elles sont présentes aussi bien en hiver qu'en été austral.



La conséquence de ces divers apports d'eau se traduit par une grande complexité de la structure verticale; c'est ainsi qu'on rencontre:

- les eaux superficielles d'une température supérieure à 22°C, d'une salinité entre, 34,8 et 35 ppm, riche en oxygène et son épaisseur est de 40 à 60 m au nord et de 80 à 100 m au sud;
- les eaux sub-superficielles au-dessous de la couche superficielle et au-dessus de l'eau intermédiaire avec, comme température, entre 15° et 23°C, une salinité élevée supérieure à 35,2 ppm, une teneur en oxygène minimale et son épaisseur est de 100 à 200 m;
- l'eau intermédiaire apparaît à 300 m de profondeur. Elle est caractérisée par une forte teneur en oxygène et une salinité supérieure à 35 ppm qui diminue au sud.

### Situation économique

Les îles des Comores sont d'origine volcanique, avec une côte rocheuse n'offrant pas de ports naturels et une végétation tropicale luxuriante. Le climat est tropical-maritime et les saisons sont déterminées par les moussons. Cependant, les différences climatiques sont plus liées au relief et à la distance par rapport à la mer qu'aux saisons. Des cyclones régionaux périodiques touchent des fois la partie septentrionale de l'Archipel.

La Grande-Comore (1 148 km<sup>2</sup>) s'est formée à partir de deux volcans dont l'un, le Karthala (2 300 m) qui possède le plus large cratère actif du monde, est situé au sud de l'île. La côte, qui n'est pas bordée de récifs coralliens, est d'accès difficile par la mer. La Grande-Comore reçoit des chutes de pluie importantes, mais en raison de la perméabilité du sol volcanique récent, la pluie est rapidement absorbée et ne forme pas de cours d'eau. En conséquence, elle est l'île la plus sèche, ses ressources en eau consistant à recueillir dans des citernes l'eau de pluie. Toutefois, depuis 1976, on a commencé à exploiter la nappe fréatique qui entoure tout le littoral de l'île.

Anjouan par ses dimensions (424 km<sup>2</sup>) est la seconde île de l'Archipel. Contrairement à la Grande-Comore, Anjouan dispose de sols utilisables et de cours d'eau permanents. Toutefois les terres ont été soumises à une culture intensive selon des méthodes agricoles défectueuses et souffrent maintenant d'une grave érosion. Plus, une grande partie des terres n'est pas cultivable. Anjouan est entourée de récifs coralliens qui se découvrent à marée basse.

Mohéli (220 km<sup>2</sup>) la plus petite des quatre îles, a des montagnes en pente douce (et ne dépassant pas 860 m d'altitude), des vallées fertiles et bien arrosées et de longues plages de sable. Elle souffre comme Anjouan de l'érosion des sols.

Mayotte (374 km<sup>2</sup>), la plus ancienne des îles, se distingue par la faiblesse de son relief (son point culminant n'atteint que 600 m). Ses sols sont fertiles mais déjà gravement érodés. Sa côte rocheuse est encerclée d'une barrière corallienne formée d'environ 20 petites îles et qui ménage une large étendue d'eau bien abritée (le lagon).

Les Comores comptent parmi les pays les moins avancés (PAM) de l'Afrique sub-Saharienne. En 1980 le PIB par habitant était d'environ 3 375 CFA. L'agriculture est le secteur le plus important dans la formation du PIB avec une part égale à 41 pourcent. Le commerce en gros et de détail et l'administration viennent ensuite avec 24 et 15 pourcent respectivement. L'industrie ne représente que 5 pourcent.

L'agriculture emploie plus de 80 pourcent de la main-d'oeuvre. Plus de 75 pourcent des cultures sont des cultures de subsistance, essentiellement des céréales (riz et maïs), des tubercules (manioc) et des fruits (bananes et noix de coco). Les cultures de rapport, représentant la quasi-totalité des exportations, sont l'ylang-ylang, la vanille, le girofle et le coprah. En 1981 les produits alimentaires ont représenté 45 pourcent des importations, absorbant la presque totalité des recettes d'exportation. La malnutrition est encore répandue surtout les carences de protéines animales. Le rendement des cultures vivrières est particulièrement bas.

Les cultures de subsistance comprennent à la fois des arbres et des plantes annuelles qui sont souvent en association. Le long de la côte, le cocotier trouve des conditions favorables jusqu'à 400 m d'altitude et la noix de coco constitue un aliment de base, avec la banane, le fruit à pain, le manioc et un peu de maïs. Bananes, manioc et maïs sont également cultivés sur les "hauts" à l'intérieur, en même temps que le riz, l'ambrevade, le taro et certains produits maraichers. Les techniques culturales sont assez primitives. L'emploi de houes et de rateaux est peu fréquent, l'usage de semences améliorées est très rare, engrais et pesticides sont quasiment inconnus. Les paysans pratiquent la jachère arbustive mais avec l'accroissement de la pression démographique les jachères ont vu leur durée réduite et à la limite ont été abandonnées, contribuant ainsi à la baisse de fertilité du sol.

La population de la République Fédérale Islamique des Comores (Mayotte non comprise) s'éleve à 358 000h (recensement 1980). Le pays connaît actuellement une croissance démographique rapide (environ 3,4 pourcent par an) et une pression intense sur les terres arables. La densité démographique de l'Archipel est d'environ 165h au km<sup>2</sup> (1980). La population est rurale à 80 pourcent. La plupart des Comoriens habitent dans des villages proches des terres cultivables, c'est à dire dans les bas.

Si le taux de croissance actuel se maintient, le nombre d'habitants, serait de 793 000 à la fin du siècle (Mayotte incluse). La relation entre la population rurale et urbaine subit un changement de tendance, en raison de l'accroissement des populations vivant dans le milieu urbain. Cette croissance est le résultat d'un mouvement migratoire relativement important vers les villes, notamment vers la capitale, Moroni. En 1977, 18 000 réfugiés ont été rapatriés de Madagascar à la suite de troubles locaux, ce qui a encore aggravé la situation de la rapide croissance de la population urbaine. De même, des cataclysmes naturels provoquent également de sérieux problèmes. Ainsi l'éruption volcanique du Karthala en avril 1977 en Grande-Comore a laissé quelques 500 familles sans abri.

#### Les institutions s'occupant de l'environnement

Le Ministère de l'équipement, de l'habitat, de l'urbanisme et de l'environnement est pratiquement la seule institution nationale qui s'occupe des problèmes de l'environnement. Mais on peut souligner qu'à la Direction Générale de l'Environnement aucun spécialiste formé en la matière n'existe. Il y a en tout et pour tout deux agents en assainissement sanitaire qui relèvent du Ministère de la Santé.

Au niveau régional, les Préfets sont chargés de veiller à la protection de la nature (forêts, plages, sable, coraux, la pêche des tortues, etc.) mais avec des moyens extrêmement limités à cause du manque de personnel et d'argent. Dans certaines régions les populations essaient de créer leurs propres structures d'auto-surveillance, mais il faut disposer des instruments nécessaires (spécialistes et moyens financiers). Cette tentative bienveillante aussi louable soit-elle, reste

## DEVELOPPEMENT DES ZONES URBAINES ET RURALES

Les principales villes des Comores sont les suivantes: Moroni, la capitale (20 112h), Mutsamudu (12 518h), Domoni (7 658h), Ouani (7 051h), Fomboni (5 660h) et Mitsamiouli (4 258h). La physiographie du pays est responsable à la fois de la forte dispersion de l'habitat, du groupement de la population dans les zones où existent les opportunités géographiques naturelles de subsistance, ce qui provoque l'existence des zones surpeuplées et à la suite, la forte densité des zones urbaines. Il faut toutefois souligner que la population est très largement rurale et que 20 pourcent seulement vivent dans les villes de 5 000 habitants ou plus.

La situation dans le domaine de l'habitat s'aggrave à l'examen des infrastructures techniques et sociales. Notons que seulement 10 pourcent du réseau urbain du pays possède des installations d'adduction d'eau. La situation est encore plus grave à l'égard de la canalisation des eaux pluviales et des égouts, qui n'existent pas, et on doit profiter encore seulement de la grande porosité du sol d'origine volcanique. A long terme, ce procédé, selon les spécialistes, provoquera la contamination des nappes souterraines d'eau potable. Des fosses d'aisance et septiques sont utilisées partout, et elles ne présentent pas de problème immédiats dans les villages en raison de la densité rurale peu élevée, et de la bonne porosité du sol. Dans les villes, particulièrement à Moroni, aucun contrôle sérieux n'est effectué sur la construction et les fosses présentent de graves problèmes sanitaires, qui vont s'aggraver dans un avenir très prochain.

Les services de ramassage des ordures n'existent pratiquement pas. Les habitants jettent leurs déchets, soit aux alentours immédiats de leurs habitations, soit le long des routes, soit encore dans la mer. Seule une petite expérience de ramassage d'ordures est tentée à Moroni depuis la mi - 1982.

Conscient de la priorité que réclament l'organisation et le développement du réseau de l'habitat pour le développement du pays, le Gouvernement a fait appel aux Nations Unies pour l'assistance dans l'élaboration d'un premier projet d'aménagement des établissements humains. La stratégie et les objectifs généraux d'aménagement du territoire sont en cours d'élaboration. D'ores et déjà une société immobilière est en voie de création avec un programme de 700 logements de petit et moyen standing. La plupart de ces logements seront construits dans les grandes villes, Moroni, Mutsamudu et Fomboni dans la période 1983 - 1986. Il faut toutefois souligner que l'auto-construction de logements est très répandue aux Comores, et va se développer au même rythme. En revanche, la fabrication des matériaux de construction ne suit pas le rythme de développement du secteur. Seuls les éléments en bois (portes, et fenêtres) sont fabriqués sur place. La pierre de chaux d'origine corallienne, le sable des plages, et les feuilles de palmiers sont les seules matières premières locales utilisées dans la construction traditionnelle. Les parpaings sont les matériaux les plus couramment utilisés dans la construction moderne, et ils sont entièrement fabriqués à partir du ciment importé. Mise à part une brève expérience réalisée en 1978 avec des briques en terre stabilisée, aucun effort n'a encore été fait pour utiliser des matériaux ou des briques fabriquées à partir de l'argile ou de la pouzzolane. A l'heure actuelle on n'est pas en mesure de quantifier les prélèvements des coraux ni du sable des plages. Toutefois la situation est catastrophique, à telle enseigne que l'on a vu des plages, notamment au nord de la

## DEVELOPPEMENT INDUSTRIEL

L'isolement géographique du pays et les dimensions de son marché sont des contraintes qui pèsent lourdement sur le secteur de l'industrie et de la manufacture. En outre, l'exiguïté du marché fait que beaucoup de projets manufacturiers ne sont pas rentables. La part du secteur industriel dans le PIB s'élève à 4,8 pourcent (1980). Cette part qui était de 5,6 pourcent en 1976 a diminué régulièrement ensuite, essentiellement à cause de la baisse de la production des distilleries d'ylang-ylang.

Une étude effectuée par le Bureau international de travail (BIT) sur la main-d'oeuvre indique qu'au 30 juin 1980, il y avait 125 établissements industriels avec un effectif total d'environ 700 personnes. Ces établissements, qui sont pour la plupart situés dans les grandes villes ou à proximité de celles-ci, exercent leurs activités dans les domaines suivants: boulangerie, production et mise en bouteilles de boissons sans alcool et d'eau gazeuse, confection, scierie, fabrication de meubles, imprimerie, savonnerie, distillation de l'ylang-ylang, bijouterie et artisanat. A souligner que le traitement des gousses de vanille, du girofle et du coprah est considéré comme activité agricole. Tous ces établissements, à l'exception d'une distillere d'ylang-ylang (la SCB) peuvent être considérés comme de moyennes ou de petites entreprises et sont également répartis entre les îles de Grande-Comore et d'Anjouan. Aucune activité industrielle n'a été enregistrée à Mohéli.

Il y a quatre boulangeries aux Comores, deux à la Grande-Comore, deux à Anjouan. Elles fabriquent essentiellement du pain et de la pâtisserie simple. La farine de blé est importée.

- La seule entreprise de mise en bouteille de boissons non-alcoolisées et d'eau gazeuse se trouve à Patsy (Anjouan). Créée en 1973, elle a commencé à produire en 1975. Ses capitaux étaient en majorité étrangers mais viennent d'être cédés en 1982 à des intérêts locaux.
- Une vingtaine de petits tailleurs travaillent sur mesure. Les vêtements de confection sont importés.
- On dénombre 59 menuiseries fabriquant du mobilier et des portes et fenêtres. Les plus importantes sont à Moroni et à Mutsamudu. Les copaux sont jetés devant les menuiseries, ce qui constitue un foyer de pollution dans les villes.
- Il existe trois scieries. Cependant, l'exploitation forestière étant sévèrement limitée, seule la scierie de la Grande-Comore, qui appartient à une société étrangère (la SAGC), est pleinement opérationnelle. Sa production est de 7 m<sup>3</sup> par jour. Les grumes proviennent des forêts de 7 400 ha que possède l'entreprise dans le sud de l'île.
- Une seule imprimerie existe aux Comores, créée en 1979.
- La savonnerie, située à quelques kilomètres au nord de Moroni a été créée en 1974. En 1980 elle a produit 197 tonnes de savon de ménage à partir du coprah local, alors que sa capacité installée est de 400 tonnes par an. Le tourteau provenant de la savonnerie est quelquefois utilisé pour fabriquer de la provende pour l'aviculture.
- Les distilleries d'ylang-ylang en sont arrivées à utiliser comme combustible presque exclusivement du bois, qu'elles se procurent parfois d'une façon illégale et cela à cause de l'augmentation du coût du mazout. Cette

augmentation est à l'origine aussi de la fermeture d'un grand nombre des petites distilleries. Une grande distillerie à Bambao appartient à la SCB (capitaux étrangers) et produit environ deux tonnes par an (1981). Le reste de la production est assurée par de petites distilleries, très peu efficaces, et dont la production est inférieure à une tonne par an. Des efforts sont faits pour utiliser l'énergie solaire mais les résultats restent peu probants.

- On compte 16 bijouteries dont 14 à la Grande-Comore. Toutes sont en réalité des échoppes d'artisans, fabriquant des bijoux d'or et d'argent exclusivement destinés au marché local.
- On dénombre 10 000 artisans travaillant dans les services, l'artisanat artistique et de petites fabrications. Ils produisent des articles en textile, de la vannerie, de la poterie et des pièces de bois sculptées.

#### OUVRAGES HYDRAULIQUES ET INSTALLATIONS HYDRO-ELECTRIQUES

Bien que les îles des Comores soient volcaniques, chacune possède des caractéristiques bien distinctes dépendant des phases volcaniques qui les ont marquées. La Grande-Comore, la plus récente, présente la particularité de n'avoir aucune rivière. Le sol est peu profond et trop perméable. On est alors en présence d'une nappe aquifère d'eau douce sur l'eau salée venue de la mer par infiltration, et la population est obligée de recueillir les eaux de pluie dans des citernes. Seul dans la capitale à Moroni, un forage muni d'une station de pompage rudimentaire et d'un réservoir, fournit de l'eau à la ville.

A Anjouan, la deuxième île en importance, le massif central est bien irrigué mais les extrémités sont plutôt arides et dénudées. Plus ancienne que la Grande-Comore, Anjouan a des cours d'eau permanents. Toutefois un phénomène d'érosion du sol est très marqué dû principalement à de mauvaises techniques de culture et à une dégradation des forêts. La présence des cours d'eau permanents permet l'alimentation en eau à la population. Mayotte et Mohéli présentent la même situation qu'Anjouan.

Hydroélectricité: Seule l'île d'Anjouan possède trois centrales hydroélectriques interconnectées établies par la Société Bambao (étrangère) alimentant les installations de leurs plantations. Actuellement seule la Centrale de Marahani est en état de fonctionnement. Les centrales hydroélectriques n'utilisaient pas pleinement le potentiel énergétique des rivières sur lesquelles elles se situent. C'est pourquoi un programme d'aménager les sites est en cours d'élaboration et dont une partie du financement est déjà acquise. Le programme intègre aussi une micro-centrale hydroélectrique à Mohéli. L'ensemble de ce programme n'aura pas d'incidences sérieuses sur l'environnement, étant donné que les réalisations ne sont que des micro-centrales hydroélectriques.

#### TRANSPORT

L'isolement géographique du pays, le fait que les îles sont éloignées les unes des autres, et le caractère accidenté du terrain exacerbent les difficultés dues à l'insuffisance des moyens de transport et de l'infrastructure des transports, sur

les îles, entre elles, et entre l'Archipel et le reste du monde. L'expansion économique prévue et la poursuite de l'intégration de l'économie et du marché du pays supposent l'amélioration des transports.

### Transports routiers

Le développement des transports routiers semble suivre le développement économique, avec l'augmentation du nombre des véhicules à moteur et l'amélioration du réseau routier. Les routes longeant les côtes des deux îles principales sont terminées et d'autres travaux de construction et d'amélioration du réseau sont en cours. Néanmoins, en raison du caractère accidenté du terrain, le réseau routier ne pénètre pas encore dans bon nombre de zones rurales, dont certaines sont très fertiles, ce qui rend difficile le transport des produits agricoles vers les villes. La plus grande partie des produits agricoles est transportée à dos d'homme à cause des difficultés d'accès de certaines régions et du coût relativement élevé des transports. L'emploi de bêtes de somme ou de trait qui constituerait un progrès, ne paraît pas acceptable pour des raisons de tradition, ni possible dans certaines régions rurales à cause de la nature volcanique du sol.

Le nombre d'automobiles et de véhicules utilitaires jugé suffisant pour les besoins actuels se situe entre 1 800 et 2 600, dont 60 pourcent à la Grande-Comore, 40 pourcent à Anjouan et un chiffre négligeable à Mohéli. Sur ce total, 535 véhicules sont des taxis et 200 des véhicules officiels. 60 pourcent des taxis sont des "taxis-brousse" qui sont des camionnettes à ridelles utilisées dans les zones rurales. Les 40 pourcent restants sont des breaks utilisés essentiellement dans les villes. Les quelques véhicules utilitaires appartiennent à des commerçants, à des entrepreneurs et à l'Etat.

### Transports maritimes

Le commerce extérieur, qui joue un rôle important dans l'économie du pays, nécessite de bonnes liaisons maritimes internationales. Il faut aussi de bonnes liaisons inter-îles à cause de la spécialisation agricole des îles et de l'impossibilité d'installer sur chacune une large gamme d'établissements. Les déficiences de l'infrastructure et la détérioration des navires font que les transports maritimes sont insuffisants.

Le transport des marchandises et des passagers entre les îles est assuré par une péniche de débarquement à fond plat de 90t en très mauvais état. Dernièrement le pays vient d'acquérir un petit "beacher" de 300t. Un petit cargo de 300t assure le transport surtout des hydrocarbures liquides, un peu de fret et quelques passagers. Plusieurs boutres de bois, 8 à 10m de long, navigant à moteur ou à voile et dont aucune compagnie d'assurance n'accepte d'assurer le chargement, complètent la flotte du pays.

La société nationale des transports maritimes (SONATRAM), créée en septembre 1982, possède également trois cargos hors service dont un pourrait devenir opérationnel après réparation. Les plans d'expansion de la SONATRAM prévoient l'acquisition des navires suivants:

- un pétrolier de 2 500t pour assurer la liaison régulière des produits du raffinage du pétrole en provenance de la région du Golfe;
- un cargo de 2 300 à 3 000t pour assurer la liaison avec les pays voisins et l'Europe.

L'infrastructure maritime est en voie d'amélioration. Des travaux d'agrandissement du port de Mutsamudu à Anjouan ont commencé au début de cette année et vont durer trois ans. Le nouveau port en eau profonde pourra recevoir à quai des navires de 15 000t et devenir ainsi le port international et d'éclatement des Comores. A Mohéli, où il n'existe pas actuellement d'installations portuaires, le Fonds européen pour le développement (FED) finance une partie de la construction et de l'équipement d'un petit port destiné au trafic inter-îles. Le port de Mironi en Grande-Comore fait aussi l'objet d'aménagements financés en partie par le FED.

Les exportations comoriennes se composent essentiellement de quatre produits: les essences d'ylang-ylang, la vanille, le girofle et le coprah, pour un volume global annuel de plus ou moins 2 500t, tandis que les importations représentent un volume annuel moyen de 83 000t. Elles sont caractérisées par la part élevée des produits alimentaires (30 000t). Le riz seul avec 25 000t par an représente 15 à 25 pourcent des importations.

#### EXPLOITATION DES RESSOURCES BIOLOGIQUES DE LA TERRE

Son origine éruptive et sa position géographique confèrent à l'Archipel des Comores un sol et un régime climatique peu favorable à une exploitation agricole intensive. La prédominance de microclimats très contrastés (trop secs ou trop humides) réduit sensiblement l'étendue des secteurs convenant à chaque gamme de plantes cultivées. Les sols sont de structure fragile ou contraignante, peu profonds, exposés et sensibles à l'érosion, et chimiquement peu riches.

Selon l'étude effectuée par l'IRAT en 1977 sur des propositions d'affectation des sols, les surfaces retenues comme polyvalentes correspondant à des sols de bonne qualité physicochimique de profondeur supérieure à 50 cm et dont la pente n'excède pas 19 pourcent sont de l'ordre de 17 000ha. Les surfaces "surclassées" prélevées se situent sur les pentes comprises entre 13 et 60 pourcent et présentent des contraintes importantes quant à la texture ou la pierrosité; elles couvrent 34 100h. Enfin une partie importante de terre est occupée totalement ou de manière diffuse par des cultures commerciales pérennes.

L'économie vivrière reste fondée sur l'exportation du cocotier et à un degré moindre sur les productions des bananes (33 000t/an), des tubercules (33 000t/an), de riz de montagne (3 600t/an), des légumineuses (5 700t/an), fruits (2 400t/an) et des légumes et feuilles qui sont des cultures de case.

Les techniques de production sont archaïques. La disposition de la forêt, la pression croissante sur la terre, donnent naissance à des systèmes et des techniques dont le degré d'évolution marque une position transitoire partagée entre des habitudes de cueillette et la nécessité de cultiver pour produire. Dans les bas, la culture vivrière est fortement conditionnée par l'omni-présence diffusée des cultures commerciales. Dans les hauts où le paysan ne bénéficie pas des revenus des cultures de rente, le système de culture est plus évolué et plus intensif.

Les techniques culturelles sont rudimentaires et primitives. La préparation du sol est faite au bâton ou au couteau fouilleur. L'entretien se réduit au désherbage réalisé à la main ou à l'aide d'un couteau. L'utilisation des fertilisants organiques et minéraux et à plus forte raison celle des pesticides, est ignorée. La protection des sols contre l'érosion n'est pratiquée qu'à la Grand-Comore où elle procède d'une longue tradition.

On peut retenir comme domaine agricole exploité de l'ordre de 75 000ha réparti de façon théorique en trois espaces:

- 38 000ha - réservés aux cultures vivrières annuelles ou pluriannuelles;
- 31 000ha - à la cocoteraie et cultures arbustives fruitières;
- 6 000ha - aux cultures commerciales (compte non tenu de la vanille associée au cocotier).

L'élevage, activité d'appoint des populations, entre pour une part relativement réduite dans l'économie comorienne. Toutefois son rôle est fondamental dans l'équilibre nutritionnel. Les estimations des effectifs animaux pour l'ensemble des îles datent de 1973. En l'absence de statistiques plus récentes, on admet les effectifs suivants: 40 000 bovins, 5 000 ovins, et 45 000 caprins. La production, annuelle de viande est estimée à 540t pour les bovins, 190t pour les ovins-caprins. Il faut ajouter 100t de viande de poulet provenant à part égale de l'élevage traditionnel et de l'élevage moderne, 800 000 litres de lait et 2 millions d'oeufs.

## LA PECHE

Les quatre îles de l'Archipel contrôlent dans un rayon de 50 km de leur côtes une zone océanique d'environ 100 000 km<sup>2</sup>. Leur nature volcanique, présentant un relief tourmenté, se prolonge sous la mer et rend difficile la pêche par des moyens autres que des filets de surface ou des palangres. A l'exception de Mayotte qui est entourée d'une barrière de récifs coralliens, à l'intérieur desquels s'étend une lagune d'environ 800 km<sup>2</sup>, les trois autres îles présentent un plateau continental étroit, y compris une zone de hauts fonds entre Mayotte et Anjouan sur une longueur de 60 km. Le plateau continental peut être estimé à 2 600 km<sup>2</sup> dont 60 pourcent rattachent au système sous-marin de Mayotte et 40 pourcent au système sous-marin des trois autres îles. La marée moyenne y est de 4m et les îles sont baignées du courant sud-équatorial qui se déplace vers l'ouest à la vitesse de 4m/sec. La température surface oscille entre 24° et 27°C.

La pêche pratiquée actuellement aux Comores est uniquement de type artisanal. (Il n'y a pas d'activité de pêche industrielle.) Elle représente 8 pourcent du PIB, et environ 7 000 pêcheurs, dont une partie est employée à plein temps, qui vivent dans une centaine de villages le long des côtes de la Grande-Comore, Anjouan et Mohéli. Ils sont équipés d'environ 3 000 à 3 500 pirogues à balancier et pêchent principalement à la main (palangrotte).

On ne dispose pas de données statistiques concernant le niveau de revenu des pêcheurs mais la pauvreté de leurs équipements et l'absence de moyens de conservation du poisson montrent qu'ils ont un niveau de vie extrêmement bas. La production est estimée à 4 000t, vendue en frais aux consommateurs, souvent directement à la plage. Le salage-séchage est pratiqué à Mohéli mais sur une petite quantité. La demande locale de poissons frais n'est pas satisfaite. Il en résulte un niveau de prix au détail assez élevé: plus de 700 Frs. comoriens le kg de poisson à Moroni.

La technique de pêche la plus commune est la ligne à la main (palangrotte); les lampes, type "Pétromax" sont souvent utilisées pour attirer le poisson. Les filets sont rarement utilisés sauf à Anjouan et Chindini (Grande-Comore). Les pirogues ont un double balancier et mesurent 3 à 7m de long et 0,5m de large. Les pêcheurs utilisent généralement la pagaie et quelquefois la voile. Les moteurs hors-bord sont presque inexistantes à cause de la taille réduite des pirogues. A Moroni, il y a



environ cinq à six bateaux motorisés qui appartiennent à des particuliers, lesquels les utilisent pour remorquer les pirogues, recevant en retour une partie de leur prise de poissons. Récemment le Japon a fait un don au Gouvernement comorien d'une centaine de pirogues à moteur en matière plastique. Ces petits bateaux de pêche vont quelque peu améliorer la pêche artisanale et permettront d'augmenter sensiblement le taux d'exploitation de ressources démersales et halieutiques. Le développement de la pêche industrielle ne peut être envisagé à court terme du fait de l'insuffisance des appâts (sauf dans le lagon de Mayotte), de l'absence d'infrastructure portuaire appropriée, du manque de pêcheurs qualifiés et de l'importance des investissements initiaux à consentir.

La production totale des trois îles (Grand-Comore, Anjouan et Mohéli) est estimée à 4 000t/an dont 55 pourcent est constituée de thon, le poisson démersal et pélagique côtier comptant pour 1 800t et le thon 2 000t. La consommation moyenne annuelle par tête est d'environ 13 kg de poisson frais (alors que celle de la viande est de 4 kg/h/an). Mais il faut noter que 60 pourcent des prises sont consommées dans les villages des pêcheurs. Le poisson est vendu directement sur la plage aux consommateurs. Durant la haute saison de pêche, les pêcheurs vont dans les centres urbains vendre le poisson. Les paysans de l'intérieur vont également dans les centres de pêche où le poisson est échangé contre des produits agricoles. Il en résulte que l'infrastructure de commercialisation est très réduite. Il n'y a pas de taxes ou de prix fixes pour le poisson.

Il n'y a pas de port de pêche dans l'Archipel. Pas plus d'ailleurs que d'entrepôts frigorifiques ni d'équipement de congélation. La construction de fabriques de glace et d'infrastructures de congélation et de conservation du poisson a été entreprise dans chaque île mais elle n'a pas été complétée. La SODEPEC nouvellement créée et appuyée financièrement par la Banque africaine pour le développement (BAD) compte relancer le projet pour améliorer la production, la consommation et la distribution. En effet le projet financé par la BAD comporte la création de flottilles de petits bateaux de pêche motorisés (le don du Japon en constitue une partie), la fourniture de fonds nécessaires à l'achat, et à leur distribution aux pêcheurs d'équipements de pêche améliorés, la construction d'installations pour faciliter l'abordage, ainsi que l'installation de systèmes de conservations sous-froid et de congélation, l'achat de véhicules et la formation de techniciens comoriens de niveau moyen. Il permettra d'augmenter sensiblement le taux d'exploitation des ressources démersales et halieutiques dans la zone des 12 milles nautiques réservées à la pêche artisanale.

#### PROSPECTION ET EXPLOITATION DES RESSOURCES MINERALES (CORAIL ET SABLE)

Toutes les îles des Comores sont d'origine volcanique relativement récente. Elles n'ont aucun lien géologique avec Madagascar ni avec la région côtière de l'Afrique qui leur est proche et ne semblent pas posséder de gisement minier d'intérêt économique, malgré l'absence d'une étude systématique de prospection minière. La côte est généralement constituée de laves noires corailleuses et de basalte mais comporte quelques plages sablonneuses.

Les seules ressources qui existent sont le sable, les coraux et la pouzzolane qui sont utilisés par l'industrie du bâtiment. En effet les travaux publics dans le PIB est de 9,2 pourcent en 1980 et devrait continuer à se développer fortement dans les années à venir. Seulement l'auto-construction de logements est très répandue. En revanche la fabrication des matériaux de construction ne suit pas ce rythme. Ainsi

la pierre à chaux d'origine corallienne, le sable et quelque peu la pouzzolane sont les seules matières premières utilisées pour la construction en dur. Mise à part une petite expérience réalisée en 1978 avec des briques de terre stabilisée aucun effort n'a encore été fait pour utiliser des matériaux ou des briques fabriqués à partir de l'argile.

Il s'en suit une destruction du récif corallien protégeant les côtes des îles, à un rythme inquiétant. Bien qu'il n'existe pas de moyens pour quantifier les tonnes de coraux prélevées sur le récif, on peut estimer que ce prélèvement posera d'énormes problèmes sur l'équilibre écologique des zones côtières. Déjà dans certaines régions à Mohéli et à Anjouan, quelques villages côtiers sont menacés. A cause de la destruction du récif corallien qui sert de brise-vagues au large des côtes, les vagues arrivent avec force sur les côtes et usent ces dernières. Donc, les villages côtiers en arrivent à construire des digues de protection. Le cas du village de Bibini à Anjouan est typique. En effet presque chaque année les habitants du village sont obligés de reconstruire la digue protectrice après la saison des moussons. Soulignons à titre d'information qu'à Mayotte, le récif de corail dans le lagon est atteint par une bactérie encore inconnue. Une étude effectuée par l'ORSTOM est en cours.

Le sable rentre aussi dans les matériaux de construction; mélangé avec du ciment il sert pour la fabrication des parpaings. Alors les plages sont la source toute désignée. Là aussi, pas de statistiques pour déterminer les quantités de sable prélevées sur les plages. Toutefois on a vu en l'espace de quelques années des plages entières disparaître de la carte notamment dans la région nord de la Grand-Comore.

La pouzzolane est utilisée aussi pour la construction mais en quantités très limitées. Pendant les années soixante et soixante-dix les Comores ont exporté la pouzzolane vers Madagascar. En effet la pouzzolane rentre dans la composition de fabrication du ciment et une entreprise malgache s'approvisionnait aux Comores. L'opération a cessé depuis 1974. Soulignons que pour le moment l'extraction de la pouzzolane ne pose aucun problème majeur. Au contraire, la pouzzolane active, qui est en quantité abondant, pourrait servir de substitution aux matériaux de construction traditionnels - coraux et sable - puisqu'elle a les caractéristiques nécessaires pour remplacer ces deux produits. Il ne manque qu'une étude approfondie sur l'utilisation de la pouzzolane dans la construction. Celle-ci est d'autant plus nécessaire du fait que non seulement la pouzzolane peut remplacer le sable et les coraux, mais aussi, c'est la solution finale pour empêcher la destruction de l'environnement côtier et marin.

## TOURISME

Les Comores, avec leur climat tropical, l'intérêt de leurs vieilles villes, leur végétation tropicale luxuriante et leur faune variée, disposent d'attraits qui conviennent à une clientèle touristique aisée. Chaque île comporte des traits qui lui sont propres: Grande-Comore, son volcan spectaculaire, un des grands cratères du monde, Anjouan ses paysages montagneux, Mayotte, sa lagune de coraux et Mohéli, ses plages sauvages et désertes.

En 1980, il y a eu 5 000 arrivées aux Comores. Sur ce nombre 1 900 personnes seulement séjournaient dans les hôtels. La plupart d'entre eux étaient aux Comores pour affaires ou pour travailler à des projets d'aide extérieure. La capacité hôtelière du pays est actuellement de 103 chambres réparties en cinq hôtels qui occupent environ 120 employés.

Jusqu'à une date récente, cette capacité hôtelière était sous-utilisée parce que les liaisons internationales étaient mauvaises et que les Comores n'avaient pas de contacts avec les agences de voyage internationales et les chaînes hôtelières. Depuis quelque temps cependant, l'amélioration des liaisons aériennes internationales, l'association récente avec une chaîne hôtelière et bientôt avec une autre, l'accroissement de l'aide et l'organisation de plusieurs conférences et réunions internationales ont contribué à remplir les hôtels.

Ces deux projets hôteliers susmentionnés porteront la capacité hôtelière à 500 lit environ, ce qui devrait suffire pour les besoins de la décennie en cours. Cependant il est très peu probable que le tourisme de masse puisse s'installer aux Comores comme dans les îles voisines, Seychelles et l'Ile Maurice car les plages sont petites et peu nombreuses. Les autorités favorisent une évolution prudente de ce secteur et préfèrent encourager le tourisme de qualité.

#### BIBLIOGRAPHIE

Aubray, R. (1976) La pêche maritime aux Comores, Rome.

F.A.O. - O.A.A. Société Centrale pour l'équipement du territoire international (1974). Projet de création d'une pêche industrielle au Ithon aux Comores.

Bureau Régional de l'Afrique de l'Est Banque Mondiale (1979) Les Comores: Problèmes et perspectives d'une économie insulaire de petite dimension.

Direction Générale du Plan (en cours de préparation) Documents du plan intérimaire 1983-1986.

Rapport de mission sur l'évolution des besoins d'aide en matière de population (1982) Rapport No. 48, FNUAP.

Programme de coopération Banque Mondiale/ONUUDI (1982) Etude de quelques secteurs économiques, (Rapport No.22).

Etude d'ensemble des problèmes maritimes de l'Archipel des Comores (1974).

Projet CNUH-Habitat COI 79-009 (1982) Habitat social et développement urbain aux Comores, Avant-Projet.

Projet Habitat (1982) Promotion de l'habitat aux Comores, (document de travail) COI 79-009.

TANZANIA NATIONAL REPORT : by G. Kamukala

BACKGROUND INFORMATION

Tanzania lies just south of the equator between the Great Lakes (Victoria, Tanganyika and Nyasa) and the Indian Ocean. Its area, including 59,050 km<sup>2</sup> of inland waters, is 945,050 km<sup>2</sup>, all of which, except for a narrow belt, lies at an altitude of over 300m. To the west of the Indian Ocean, stretching from the border of Kenya to Mozambique, there are five regions in addition to Zanzibar and Pemba Islands: Tanga, Dar es Salaam, Coast, Lindi and Mtwara.

The Indian Ocean coast is characterized by sweeping sand beaches, rocky outcrops and developing fringing coral reefs. It is broken by sandstone cliffs and estuarine inlets with swamps and mangrove areas. Coral reefs do not occur at the mouths of seasonal streams. This is due to the silt load of the water and the unavailability of hard substrata at such locations. They are also interrupted by the entrance of several rivers of which the Rufiji, the Ruvu, the Pangani and the Mbwankulu are the major ones.

The presence of coral reefs plays a significant role in the susceptibility of an area to erosion as they create a barrier which protects the beaches. Unfortunately, coral reefs in the vicinity of urban centres (especially Dar es Salaam, Tanga and Mtwara) are subject to frequent blasting by fishermen. In Dar es Salaam, for instance, along the Africana - Kunduchi area, much of the coral reef has been destroyed to a great extent by dynamite fishing, hence exposing the area to erosion. The explosions smash the corals and consequently the productive reefs are reduced to lifeless rubble resembling bomb craters. The habitats where fishes and other reef-dwelling organisms live, feed and breed are destroyed. In some cases, the coral reefs are damaged by excessive siltation caused by soil erosion due to deforestation and poor agricultural practices close to rivers. Harbour development, involving dredging and dumping, damages reefs around Dar es Salaam due to siltation. Nevertheless, the spectacular beauty of coral formations and reef communities is a rich heritage of the people of Tanzania and a principal attraction to tourists visiting the coast.

The coastline stretches 800 km along the Indian Ocean from the Kenyan to Mozambiquan borders with a 200 miles wide offshore Exclusive Economic Zone (EEZ). The coast has a very narrow strip of continental shelf varying from about 6 km wide to a maximum of 64 km at areas around Mafia, Zanzibar and Pemba Islands. Its extent is from 4°39" to 10°28"S and it has an area of 18,509 km<sup>2</sup> (FAO, 1979). The continental shelf area of each region is as follows: Coast 8,100 km<sup>2</sup>, Tanga 2,200 km<sup>2</sup> and Mtwara 1,860 km<sup>2</sup> (Wijkstrome, 1974). Although it has the most limited continental shelf, Mtwara has the highest concentration of fishing vessels.

There are numerous small islands off the coast. Some are raised fossil coral platforms, others are sand banks. These support some territorial vegetation and fauna (including for instance the giant coconut crab, *Birgus latro* (Linn.)). The smaller islands do not support human settlements due to the unavailability of fresh water though they are visited by fishermen for short periods. Some of these islands are critically important for the nesting activities of turtles and birds. Maziwi, North Funjore, Shungu Mbili, Nyororo, Barakami are the most important nesting grounds. The main islands of importance offshore are Zanzibar, Pemba and Mafia, all of which stand on coral flats. Mangroves are common in sheltered bays and estuaries.

They provide a substratum and shelter for many important species of fish and prawns, particularly in the predator-prone juvenile stages. Estuaries of large rivers, e.g. the Rufiji, along the coast have extensive deltas forested by mangroves. They are highly productive, contributing to the detritus chain as leaves are washed out into the offshore waters. However, the forests are threatened by intensive cropping for poles and firewood and by clearance of large areas for salt production - it is disheartening to observe such expanded clearing of the Kunduchi mangroves, north of Dar es Salaam.

#### Land-based sources of pollution

Industrial and domestic effluents are the major pollutants discharged into streams and eventually to the ocean. When they are concentrated, or contain certain non-degradable substances, they may harm the marine ecosystem.

Whereas heavy metal pollution is no longer a problem in Tanzania due to the low level of industrialization and unsophisticated agricultural practices, the renewed search for sources of minerals being extended to the sea may nevertheless result in increased marine pollution in localized areas. The determination to establish heavy industries in the near future may ultimately make this a big problem.

The agricultural uses of pesticides and artificial fertilizers has increased of late. The washing of organochlorines in large quantities into the sea pollutes the marine environment. Recent studies on the impact of pesticides e.g. DDT on marine organisms have demonstrated that concentrations that are not sufficient to control many species of pestiferous insects can kill or immobilize crustaceans, fishes and molluscs, and disrupt their schooling and feeding behaviour.

#### Climate

The coastal areas are normally hot and humid with little variation in temperature. Nevertheless it is the distance from the Indian Ocean and the altitude that mainly determine the climate. For Dar es Salaam the mean daily temperature is about 26°C, the mean seasonal range about 4°C and the daily range close to 8°C. The relative humidity reaches 100 per cent on nearly every night of the year and rarely drops below 55 per cent during the day. Average rainfall is usually under 1100 mm in a year but for some years the total rainfall is 50 per cent above or below this level. For the Tanga region it is 1,200-1,400 mm per year in the coastal strip and decreases inland, for instance 850 mm in Handeni town and only about 500 mm per year in the Masai steppe. Rainfall also increases with altitude and reaches 1,500-2,000 mm (depending also on slope direction) in the Usambaras. For Mtwara the mean annual rainfall ranges from 1,133 mm at Mtopwa to 832 mm at Lukwira Mission. The annual pattern of mean monthly rainfall is single peaked with the maximum month's rainfall occurring in January, but occasionally in February and March. The highest monthly mean air temperature is 27°C in December and the lowest 23.8°C in July. Relative humidity varies from 87 per cent in March to 79 per cent in October at Mtwara. In inland areas of the western part of the region it is about 10 per cent less in October.

The overall wind patterns are part of the system of prevailing trade winds as they impinge on the East African coast. Wind patterns are influenced by the movement of the inter-tropical convergence zone (ITCZ) creating the north-east wind (November-March) and east winds (May-October) along the East African coast. The period between June and September is generally dry and cool. The climate variations influence the intensity and formation of wind-generated waves and currents.

Around Dar es Salaam tides are of the mixed diurnal type. Hartnoll (1974) notes the main spring range for Dar es Salaam port as being 3.14 m, the mean neap range 1.13 m and the maximum tidal range as 4.74 m. The tidal amplitude according to Hartnoll is appreciable. As a result there is a large inter-tidal zone and strong tidal currents in the inshore area. In this regard, islands interrupt prevailing wave patterns and provide shelter for coastal areas behind them. As a result of interruption of wind and current flow there is a northward net movement of sediment. There is practically no ocean upwelling in the northern area of the coast.

The Tanzania mainland coast supports five administrative regions, namely Dar es Salaam, Tanga, Coast, Lindi and Mtwara. A small fraction of the coastal population depends on fishing and selling fish. This is demonstrated by the following: in Tanga Region with a population of 1,038,592, according to the 1978 census only 4,000 people depended on this activity. Further inland, agriculture and livestock-raising are predominant. It appears that the high population growth rate is not based on natural causes but on immigration because of the expansion of sisal estates and other agricultural and fishery activities. The population structure is characterized by an overall surplus of men over women (106:100) particularly in sisal-growing areas in Muheza, Pangani and Korogwe. Generally about 90 per cent of the Tanzania population depends on agriculture. The total coastal population is 3,147,344 (1978) of which about 2,600,000 are engaged in agriculture, 600,000 in commerce, 40,000 in industry and 12,000 in fishing.

#### Country GDP

The Tanzania economy depends heavily on agriculture which accounts for almost 40 per cent of the GDP and 70 per cent of exports. The majority of the population derives its livelihood from subsistence farming. The industrial sector of Tanzania is still small although the manufacturing industry has been growing rapidly in recent years. The average growth rate of GNP from 1970 to 1980 was about 5 per cent per annum which is 1.7 per cent less than that envisaged in the long-term plan. The low level of production adversely affected many important economic activities and sectors and manifested itself through food shortages, inadequate supplies of various essential commodities, large deficits, etc. All these factors further contributed to the decline in productivity and deficiency in both the directly productive and the service sectors. 1982 was another bad year in which the decline in real GDP continued. According to tentative estimates, GDP continued at 1966 constant prices and declined 3.2 per cent following another decrease of 1.7 per cent in 1981. The negative rate of growth of GDP was primarily caused by poor performance in the productive sectors like agriculture, mining and industry, which are the cornerstones of the economy.

#### Infrastructure dealing with environmental issues

In Tanzania there is still no national body with a legal mandate to co-ordinate environmental issues. There are several bodies that deal with issues falling under their sectoral responsibilities, without co-ordination and co-operation. In these circumstances the Government designated the Ministry of Lands, Housing and Urban Development as a catalytic and focal management body on the environment. In the light of this, the Ministry, in turn, established the Environment Protection and Management Section in the Urban Planning Division. Realizing that co-operation with other bodies was vital, the Ministry also formed an interministerial committee as a forum for exchange of information on environmental matters and to give advice to the section through regular meetings.

Currently the undisputed role of the section is to be the interim overall co-ordinator of environmental issues pending the formation of a national environment council set up for that purpose. The functional objectives of the section are:

- to lay a foundation for the envisaged National Environment Council;
- to establish co-ordination with intra/international bodies concerned with environmental matters;
- to ensure that all major development projects take into account appropriate environmental considerations (Environmental Impact Assessment) in the design stage;
- to liaise with directly concerned bodies in enforcing environmental legislation;
- to carry out research studies and investigations on the existing state of the environment;
- to promote environmental consciousness to decision makers and the public at large.

It is the hope of the section that when the proposed National Environment Council is commissioned, it will formulate at the outset a comprehensive environmental policy encompassing essential aspects of the environment.

#### Environmental matters in national bodies

##### Ministry of Natural Resources and Tourism

The Ministry is made up of five technical divisions and two supporting ones. The former comprise Wildlife, Forestry, Tourism, Beekeeping and Fisheries and environmental issues constitute a substantial part of the activities of these divisions.

##### Wildlife Division

The Wildlife Conservation Act No. 12/1974 established the concept of the conservation area which may be either a game reserve, a national park or a forest reserve. Within any conservation area, flora and fauna are protected.

##### Forest Division

A subsection of the Division, Ecological Improvement deals with the protection and development of indigenous forests. The forest resources are governed by the Forest Ordinance, Cap 389.

##### Fisheries Division

The water resources of Tanzania are covered by the Fisheries Act No. 6/1970 which empowers the Ministry to make regulations on a wide-range of matters for protecting, conserving and developing territorial waters. Under this Act, the use of substances hazardous to aquatic life for purposes of fishing is restricted if not prohibited.

#### Ministry of Water and Energy

The Water Law Office is charged with the duties of implementation of the Water Utilization (Control and Regulation) Act No. 42/1975. Briefly, these duties are concerned with the allocation of water rights, the control of extraction of water and the control of water pollution. The act, however, did not adequately spell out permissible limits of pollution. The Amendment Act No. 10 of 1981 made better provision for the control of pollution of water by incorporating the temporary effluent and receiving water standards of 1977.

#### Ministry of Agriculture

Through agricultural activities, environmental constraints have merged soil erosion, deforestation, and extensive use of agricultural chemicals.

#### Land-use planning

Before decentralization in 1972, land-use planning used to exist in each region functioning under Regional Agricultural Officers. Such units advised farmers on land use as an integrated part of agriculture. After decentralization, these units disintegrated in most regions. Realizing the importance of proper land-use planning in developing sound agriculture, the Ministry has decided to re-establish these functions at three levels: a land conservation unit at the Ministry and a committee for co-ordinating and advising on proper land use. These units have to collaborate with the Ministries of Livestock, Natural Resources, Lands and also with the Faculty of Agriculture and the Institute of Resource Assessment in tackling the problems brought about by misuse of land.

#### Environmental Protection Unit at TRPI (Arusha)

Under the Research Division of the Tropical Pesticides Research Institute (TPRI) an environmental protection section has been established. Its functions are promoting and carrying out research evaluation and dissemination of the fundamental aspects of the use and control of pesticides. The Registration Unit's functions are to supervise and regulate the manufacture, import, distribution and use of pesticides in the country.

#### Ministry of Livestock Development

This Ministry handles problems of overstocking, rehabilitating wastelands and trying to institute better methods of grazing management.

#### Ministry of Communication and Transport

Pollution from ships in sea harbours and marine areas falls under the responsibility of the Ministry of Communication and Transport. The present regulations in the 1967 Merchant Shipping Act prohibit the discharging of oil and oily mixtures from any ship within 100 nautical miles of the coast.

#### Ministry of Health

The role of the Ministry regarding air pollution is mainly advisory to the appropriate authorities. Health offices inspect factories in urban centres and on the basis of the inspection make the necessary and appropriate recommendations on remedial means. The Government Chemical Laboratory under this Ministry is engaged in the sampling and analysis of pollutants and related scientific procedures.



## Ministry of Lands, Housing and Urban Development

Physical Planning: Town and Country Planning Act, Cap 378. Physical planning is one of the major activities of the Ministry of Lands. This planning involves taking into consideration environmental factors relevant to development, particularly in the use of land when it comes to natural preservation and planning of built-up areas. The Ministry has to ensure that development decisions of different sectors are integrated for a balanced development.

### Urban Sewerage and Drainage

The Urban Sewerage and Drainage Division is charged with the responsibility of promoting sewerage and sanitation in urban areas. It has to plan, design, arrange priorities, finance and implement sewerage programmes.

### University of Dar es Salaam: Institute of Resource Assessment

Initially called the Bureau of Resource Assessment and Land Use Planning (BRALUP) it was created in 1967 as a research wing of the former University of East Africa (and now the University of Dar es Salaam). Its work has been concentrated in six areas: population resources, water development, agricultural systems emphasizing food products, distribution of social services particularly health and education, and transportation impact.

### Tanzania National Scientific Research Council (UTAFITI)

The Tanzania National Scientific Research Council, which is charged with scientific and research matters in the country, was established by Act of Parliament No. 51/1968. In collaboration with the Environment Protection and Management Section the Council handles the United Nations Educational, Scientific and Culture Organization's Man and the Biosphere Programme activities.

### Tanzania Bureau of Standards (TBS)

Under the mandate given to the Bureau by the Standards Act No. 3/1975, TBS is required to prepare, frame, modify or amend all standards, and in the performance of its functions the Bureau shall have regard to the health and general welfare of the people of the country. It was under this provision that TBS decided to undertake the subject of effluents of waste waters as one of its priority areas for standardization. Nevertheless, TBS was aware of the existence of several laws to that effect and the temporary standards on domestic sewage and industrial effluents of April 1977 proposed by the Effluent Standards Committee. At regional and local levels the infrastructure is not yet as articulate. Issues are handled depending on priorities accorded at the national level.

## URBAN AND RURAL DEVELOPMENT

### Major coastal towns

The expansion of towns gained momentum during British colonial administration. But urbanization gathered more momentum during the 1960s and 1970s especially after independence in December 1961 for two reasons: the removal of restrictions on the movement of people especially between regions, districts, towns etc.; and because urbanization as a way of life was considered suitable for the indigenous population

and not exclusively for aliens. It should be noted that independent Tanzania inherited economic structures which were externally-oriented to facilitate exports abroad. Since the economy was not regionally integrated, major infrastructure had to link with maritime transportation. These historical patterns of cultural contact encouraged and accelerated the location on the coast of major population centres with industrial facilities, namely Dar es Salaam and Tanga. Although the high tempo of urbanization coupled with industrial development stimulated growth of most urban towns, coastal towns continued to experience tremendous and unprecedented growth. The rate of growth for the urban population rose from 6 per cent p.a. between 1948 and 1957 to about 6.3 per cent p.a. between 1957 and 1967. Between 1967 and 1978 the rate increased remarkably to about 8 per cent p.a. Thus, urbanization in Tanzania has been conspicuous and has attracted much attention. The major coastal towns are Dar es Salaam, Tanga, Lindi, Mtwara and Zanzibar.

#### Dar es Salaam City

Dar es Salaam, as a major industrial and commercial centre and for a long time the national capital, has acted as a magnet for populations and functions. Further, it is a major port with an excellent harbour. This explains the growth of the city at an even higher rate during the last decade than ever before, bringing about the decision to transfer the national capital to Dodoma and the introduction of nine selected growth poles aimed at easing the city from pressure on land and congestion.

Because the boundaries have been extended, there is no accurate assessment of the population. However, taking the 1967 census figure for the city, the population was 272,821. The estimate of 1975 was 517,000, while the 1978 census reflected a population of 851,522. Currently (1983) the population is estimated to be 1,300,000.

As mentioned above, most of the major towns have grown lately in the range of 8-10 per cent p.a. over the 1967-1978 period. For Dar es Salaam the annual growth rate was 7 per cent p.a. in the decade 1948-1957 and 11 per cent in the decade 1957-1967 (compared with the national growth rate of 3 per cent). The 1978 census placed the population at 851,522, thus giving a very high growth rate of over 15 per cent p.a. (Tanzania's population is 17,048,329, showing a national average growth rate of 3.5 per cent p.a.). Today its growth rate is about 9.5 per cent p.a., a slight drop caused by the move of the seat of Government and party to Dodoma since 1972. But if the 1967-1978 trend of growth continued, the city would double its size every seven years.

From the last three censuses, we have learnt that the great population increase in urban areas in the country is caused not by natural growth but rather by migration from rural areas (estimated at 2.7 per cent p.a.). In fact, Dar es Salaam has not only the lowest birth rate in the country, it also has one of the lower death rates. The major cause of the city's and surrounding area's growth is the massive immigration, both from the region and from neighbouring countries. Due to the expansion and diversification of socio-economic activities with the subsequent increase in employment opportunities, rural-urban migration has grown significantly.

The outcome of the expansion of the city is the evolution of unplanned development which has emerged in peripheral areas of the city. The Dar es Salaam master plan depicts that 50-60 per cent of the city's population live in these areas, which are associated with very poor sanitation.

Land-use of Dar es Salaam City	Area in hectares
Planned residential	3,775
Squatter (unplanned) residential	2,349
Industrial	2,059
Institutional	6,698
Total	14,878

(Source: Dar es Salaam Master Plan 1979)

The disclosure of such unplanned residential development necessitated the establishment of the sites and services and squatter upgrading programme in 1972. It was apparent that Government had to explore a new approach towards providing housing for the low-income population usually sheltering in unplanned areas. The approach included provision of infrastructural facilities - roads, drainage, water supply, electricity and community facilities, schools, medical care, postal service and markets. The inevitable consequence of such an unprecedented urban population is seen in the present pressure exerted on urban land, housing, social and technical infrastructure, etc. Normally available services and utilities are unable to cope with urban growth, and financial constraints on the part of the Government have compounded the problem.

The slumming and squatting have always produced problems of hygiene due to inadequate sewage disposal, sanitation systems, poor garbage collection etc. There is a general aggravation of pollution from poor sanitation and a deterioration of town planning with regard to public health. For instance, public toilets in main business centres are mostly non-existent. Where they are present they are most unsatisfactorily maintained. Since 1970 the City Council of Dar es Salaam has registered damage to public lavatory units. At present, out of 71 units in the city, only 11 are functioning. Lorries which occasionally empty pit latrines appear to have no particular place far from human dwellings for dumping the toilet wastes. These lorries empty the waste into the Kijitonyama tributary at the bridge on Bagamoyo road, and they also discharge their load in hitherto empty areas in between Kijitonyama housing schemes along Bagamoyo Road. With the onset of the rains, there is no telling which other places will be polluted by the overflowing sewers, burst drainage systems or faecal wastes dumped in open places.

Nevertheless, Dar es Salaam is now served by a municipal sewage disposal system. Several pipe systems collect domestic, industrial and institutional wastes and discharge effluent to local rivers and the ocean. The problem is that the majority of the pumping stations and waste stabilization ponds are either inoperative or not working properly, except for the pond at the University. Generally, most residences and industries are served by private on-site disposal systems varying from conventional septic tanks and soak-away systems, to cesspits or pit latrines or to untreated discharge to local water courses. Since pit latrines are used by a majority of dwellers, it is recommended that the dry ventilated type, located above the high water-table to reduce the potential for ground water pollution and health hazards associated with mosquito breeding, be utilized.

The sewage disposal situation had deteriorated to such a level in 1978 that a decision was made to prepare a Sewage Master Plan for Dar es Salaam City. The study began in early 1979 and is now ready and pending implementation. The outbreak of cholera in the same year testified to the urgent need of such a plan.

In relation to water supply the city is at present served by a piped water distribution system fed by water from the Ruvu and Mzinga rivers. Water is treated at source and delivered by pumping to the distribution system where storage is

provided in reservoirs to control peak fluctuations in demand and give reserve capacity during emergencies. Three levels of service are provided to consumers by the distribution system: full building connection, stand-pipes and water kiosks. Some industries and institutions supplement their supply from the city system with private wells. Until mid-1978 water kiosks were provided to all sites and services and squatter areas. However, in accordance with the recent new policy to abolish water kiosks in urban areas, only two levels of service are recommended for new development up to the year 1999. Existing residential areas now on water kiosks should be converted to stand-pipes by the year 1984. The intention of the policy is to raise the minimum standard to stand-pipes.

In 1976, 82 per cent of households reported tap water as the main source of supply, while 12 per cent of the Dar es Salaam population was served by tap water, rivers and shallow wells.

#### Water treatment capacity

Plant	Firm capacity (million litres/day)
Mtoni	6
Upper Ruvu	84
Lower Ruvu	182
Total	272

(Source: Dar es Salaam Master Plan 1978)

Dar es Salaam underwent a major change in 1977 with the creation of Dar es Salaam Water Corporation Sole, an independent parastatal body, to run the city system together with the Ministry of Water and Energy. The Public Health Department within the city council has the duty of checking its purity through taking samples for bacteriological examination and chemical analysis and the advice of the Water Corporation. It should be noted here that water demand in the city has increased rapidly in recent years and has outstripped both the water supply and distribution facilities.

#### Tanga Municipality

Tanga has been one of the largest towns on the Tanzania mainland and is relatively prosperous. The population recorded during census periods is: 1948 - 20,619, 1957 - 38,053, 1967 - 61,058 and 1978 - 103,409 with the following annual growth respectively: 7.0 per cent, 4.8 per cent and 4.9 per cent. This indicates that from 1948 to 1967 the population trebled. It should be noted that between 1952 and 1957 there was a big boom mainly because of the rise in world prices of sisal which caused the population of this town to nearly double. Though the figures are not comparable because of the township boundaries which have changed over the years, they indicate past trends quite well. However, the population growth of Tanga has been very slow since 1967 compared to other major towns in Tanzania. This is mainly due to two factors: the sudden drop in the world market prices of sisal in the 1960s and the concentration of economic activities in Dar es Salaam after independence.

Migrants have been attracted to the town in their search for employment. Most of these came from neighbouring districts. In 1967, for instance 88,000 migrants moved in and 54,000 moved out. Thus the net migration was 34,000. This resulted in introducing sites and services and squatter upgrading schemes to cope with the migration. Areas included were Nguvumali, Gofujuu and Mwakizaro. At the same time, infant mortality rate has decreased drastically while the birth rate has remained

constantly high. This is due to improved health facilities in the area. The regional hospital is located in the municipality at Bombo/Raskazone. Also we find a number of health centres and dispensaries in the locality.

Tanga has three systems of disposal, sanitary sewers, septic tanks and soak-aways, and pit latrines. The sewers discharge untreated sewage into the Indian Ocean north of Raskazone. However, this system serves only a small portion of the town, constituting the central area. Bombo, Ngamiani, North and part of Usagara, Chumbageni and Kisosora.

Until very recently Tanga has had an acute water shortage caused by the increase in population. The recently completed Sigi River Scheme has solved the problem and Tanga now has two main sources of water supply: ground water from boreholes and the Sigi Water Supply. Boreholes are associated with several sanitation problems. Thus, efforts are being made to connect the municipal water system to the Sigi Water Supply and disconnect the borehole supply.

In low density areas we find septic tanks and soak-aways which have no sewage connection. On the other hand, high density areas which constitute the major part of the town, are served by pit latrines. In these areas, the functioning of the system depends on the ability of the land to absorb sewage. Because the sandy soil has high permeability severe problems have not yet occurred, but as the population densities increase the ability of land to absorb sewage will diminish. At present there is no direct relationship between the growth of the town and the provision of a sewerage system; the latter is lagging behind by many years. There is also need to construct a treatment plant so that pollution of the sea can be limited and health hazards can be controlled to some extent.

#### Mtwara Town

Mtwara is still a small coastal town. The 1967 census showed that Mtwara Region had an urban population of 37,900 located in one small and two major towns. These are Nachingwea (4,100), Mtwara Mikindani (20,410) and Lindi (13,300). Note that Lindi and Nachingwea are now included in Lindi Region and no longer in Mtwara Region. The recent 1978 census gave Mtwara a population of 48,510 with an annual growth rate of 8.2 per cent (in the period between the census of 1957 and that of 1967 the growth rate had been 3 per cent p.a.). This reflects a high rate of growth though the extent of urbanization is still very small.

During the second Five-Year Plan (1969-1974), like Tanga, Mtwara was selected as a growth centre for the south-eastern part of the country. But despite that, the population did not increase as anticipated. Further, when we consider the zero to one year age group as a percentage of the total population, in the twelve months before the 1978 census Mtwara was the lowest of any regional capital, suggesting a lower birth rate.

The town is so dispersed that problems of sanitation are not yet obvious. Water supply has been a major problem to the town and the region at large. The Finnwater project is geared to finding solutions to the problem and a water master plan is being prepared. Meanwhile, an increasing population has had to share limited amounts of water. Maximum pumping capacity is less than 300 cubic metres per day which gives the town population a maximum daily per capita consumption of 70 litres. This is very low for a regional capital. Thus, any further large-scale industrial development will require exploitation of new sources of supply.

### Lindi Town

Lindi had a population of 13,300 in 1967. While the 1978 census found it to be 27,300, thus showing an annual growth rate of 6.7 per cent. The increase here is also due to activities which encouraged the migration of people to town. The Regional hospital is here for instance, and consequently there are specialists in the staff who can handle serious cases. In 1978 the hospital had 133 beds and has now been expanded to accommodate 187. The town is also served by a dispensary. The emphasis is on preventive health measures and public health services are given priority.

In Lindi less emphasis has been given to the development of urban water supplies. It is estimated that three quarters of the region's urban population live within easy access of a water distribution point. Reliability of supply is, however, not good due to both poor maintenance and inadequate water sources. In Lindi town a second pipeline was completed in 1977 from the existing town source at Mmongo springs, to serve the new cashewnuts factory. However, as demand exceed the reliable supply from Mmongo, a crash programme to take water from Kitunda springs on the eastern side of the Lukuledi estuary was implemented in 1979.

### Rural development

It was recorded in 1978 that 95 per cent of the country's population lived in about 8,210 rural settlements. A decade ago rural dwellers used to live in scattered homesteads surrounded by small farms. The distance between homesteads ranged between 40 metres and 5 km, but for a majority of the settlements the distance fell between 2 to 5 km apart. With such a pattern it was difficult, if not impossible to provide services and facilities to rural dwellers. The transformation from scattered homesteads to compact rural settlements was achieved through the "operation vijiji" in the early 1970s. Now, efforts are focused on the equitable provision of community facilities based of course on priorities to the relatively new settlements. However, these settlements were created haphazardly due to the absence of physical plans.

Under the Villages and Ujamaa Villages Act each village has an elected chairman and a committee responsible for controlling its affairs, and it also has the legal status of a primary co-operative society. However, one of the main shortcomings in the rural settlements network of Tanzania is the social, spatial, and economic isolation of these settlements from each other on the one hand, and from urban settlements on the other. This shortcoming manifests itself through the absence of a transport and communications network and a clearly defined hierarchy of settlements. Only four years ago, regional physical planning offices were established with, among other tasks, the responsibility to undertake rural settlement planning.

By concentrating settlements, villagization has led to some disruption of the agricultural system. Land near the village centre has become more valuable due to its accessibility and has consequently been subjected to more intensive and continuous cultivation. Distant areas, previously cultivated under the system of scattered settlements, have been abandoned. This has led to shorter fallow periods and, in certain areas where, poor soils predominate, a consequent decline in the nutrient content, structure and water-holding capacity of the soil.

### Physical planning

The Ministry of Lands, Housing and Urban Development has been given the responsibility of preparing, inter alia, land-use plans (physical plans) for

villages, wards, divisions, districts, regions and the entire country, so as to ensure the development of an adequate physical environment for the people, and to provide services to enable land to be developed economically in the best interests of the nation. There has been physical planning for urban settlements since colonial days. However, this consisted mainly of town plans and interim land-use plans showing the distribution of different categories of land-use and physical layouts including the location of social and economic infrastructures within the urban area. In the course of preparing interim land-use plans and master plans for urban centres, the Ministry of Lands, Housing and Urban Development, realized that a physical planning task must be undertaken to ensure a co-ordinated and balanced growth between urban and rural areas, because the two are functionally interrelated. The growth of one has an impact on the other. Now all Regional headquarters, including Dar es Salaam and Tanga, have master plans, while Mtwara and Lindi have interim land-use plans to direct urban development.

Tanzania is an agricultural country. There is therefore need for a kind of combined urban and rural development process which will integrate and co-ordinate urban and rural planning so that they complement each other. This is achieved through integrated regional physical planning. At present, Tanzania is divided into five zones to facilitate the preparation of these plans: Uhuru Railway Corridor, Lake Zone, Northern Zone, Central Zone and Southern Zone. The first two zones already have integrated physical plans and now the Ministry has embarked on the Northern Zone. This means that Dar es Salaam and the coastal regions are included in Uhuru Corridor, Tanga in the Northern Zone, and Lindi and Mtwara in the Southern Zone.

#### COASTAL INDUSTRIAL DEVELOPMENT

The Tanzanian manufacturing industry is very unevenly distributed throughout the country. Coast Region, with Dar es Salaam, dominates by far, with almost half of all employees and nearly 60 per cent of the value-added of the manufacturing sector, while close to 90 per cent of the industries are located in Dar es Salaam/Coast and five other regions (Mwanza, Tanga, Arusha, Morogoro and Kilimanjaro) with very little in all the rest of the country.

The coastal belt continued to attract a disproportionate share of new industries after independence. The single major attraction to industries is Dar es Salaam City which continues to command priority. Tanga has also been one of the nation's centres of manufacturing industries despite its decline due to the dwindling of sisal production and the market. On the other hand, Lindi and Mtwara attract the least industries.

In the light of the above trend, the Government suggested in the second Five-Year Plan that in future no new industries should be located in Dar es Salaam but should go to nine identified urban areas scheduled for rapid development (the growth pole concept). Nevertheless, the existing industries continued to grow and new ones were still being established in the biggest city. Over 80 per cent of the industries in Tanzania are found in urban areas, Dar es Salaam having the majority, and employing more than 61 per cent of all urban labour in manufacturing industry.

#### Dar es Salaam

There are currently about 178 industries in the 15 main industrial areas within, and in the periphery of, the Dar es Salaam urban area. Industries (including

small-scale ones) are scattered almost everywhere, but the major concentrations are found in the following areas: Chang'ombe/Pugu Road/Kipawa; Ubungo; Mikocheni/Kawa; Kunduchi/Wazo and Kigamboni.

Major Industries (1978 figures)

Industrial Sector	Number of establishments	Employment
Food	28	8,445
Textiles	21	10,899
Wood industry	20	1,210
Paper industry	21	1,845
Chemical industry	19	4,280
Non-metallic industry	11	2,717
Metal industry	29	4,850
Other industries (transport and communications etc.) located in industrial area	29	22,934
Total	178	57,180

(Source: Dar es Salaam Master Plan - Technical Supplements 1979)

Despite the low level of industrialization in the country, its impact on the marine environment should not be ignored. Precautions have to be taken to control effluents and other solid wastes from industries. The current practice of dumping these wastes into the ocean, particularly via the Msimbazi river in the case of Dar es Salaam, threatens the marine ecosystem.

From investigations it has been found that only 27 industries out of 178 could be considered serious sources of industrial pollution. The existing legislation covering the discharge of polluting matter into water courses is not enforced at present. Industries discharge their wastes as they see fit, creating some very serious pollution problems. As already mentioned above, the Msimbazi valley is a case in point. Thus, in conjunction with an industrial survey (1978), the sources of the polluting wastes have been identified; the principal ones were:

- Tanzania Breweries Ltd.,
- Vingunguti Abattoir
- Sunguratex Ltd.
- Friendship Textile Mills Ltd.
- Darbrew Ltd.
- Tanzania Road Transport Co.
- Ubungo Power Station
- Tanganyika Dyeing and Weaving Mills
- Kilimanjaro Textiles Co. Ltd.
- Tanzania Dairies Ltd.

Manufacturing areas

(a) Chang'ombe/Pugu Road/Kipawa area

A variety of industries are situated in this area and range from foodstuffs and chemicals to non-metal and metal industries. The likely pollutants in effluents are: pesticides (DDT, PCB, etc.) cyanides, metals, acids, alkalis, paints, oil spills from engines and garages, abattoir wastes, dyes and brewery wastes (alkalis and acids). Heavy metals like lead and mercury are also found. These industries do not



directly pollute watercourses.

(b) Ubungo area

Important establishments are Friendship Textile Mills Ltd., National Dairies Ltd., Dar-Brew Ltd., Tanzania/Zambia Road Services, Ubungo Farm Implements (UFI). Friendship Textile Mills Ltd. is one of the largest enterprises in Dar es Salaam and employs over 5,000 people. These establishments are likely to discharge dyes, alkalis, brewery wastes, milk wastes, engine oils and spills.

(c) Mikocheni/Kawe area

Well-known plants are: Tanganyika Packers and the National Bicycle Company. These discharge abattoir wastes, acids, alkalis, cyanide and chrome. The untreated effluent from the bicycle factory is discharged to a surface water ditch which drains to a stream that in turn discharges into the sea at Msasani Bay, while wastes from the slaughterhouse pollute the Mbezi river during the wet season.

(d) Kunduchi/Wazo Hill area

The major industries in this area are cement and asbestos plants. Here, major pollutants are the dust fumes and sulphur dioxide so that air pollution is the major problem. The effluent from the asbestos factory (a slurry containing fibrous asbestos wastes) is allowed to flow off the factory compound and into the area neighbouring Tegeta village so that people or domestic animals are exposed to the dangerous fibres either in the water from the slurry or in airborne particles if it is dried and blown by the wind.

(e) Kigamboni area

The oil refinery is located in this area. During 1981 it was programmed to process 525,100t of crude oil. The actual quantity processed was 521,379t yielding 479,976t of finished products. In 1980, 617,349t of crude were actually processed yielding 565,673t of finished products. Oil spillage containing toxic substances such as benzene, phenols and hydrogen sulphide are likely to be discharged. However, at the TIPER refinery there is no precise system to measure effluent discharge.

As mentioned above, these industries do not have proper treatment devices so that effluents are discharged into streams or the sea untreated. Note that about 80 per cent of all industries in the country are based in Dar es Salaam City. Since most of them are consumer goods factories they discharge effluents containing both organic and chemical pollutants. Furthermore most of the industries are located outside the main sewered areas and have their own systems of disposal, which are mainly direct and untreated to inland watercourses. Some discharge to stabilization ponds which are currently not working. In fact about 70 per cent of the industries in Dar es Salaam discharge directly into the Msimbazi valley (Mwaiseje and Bryceson, 1980). In some cases the same polluted water is used for small-scale irrigation, for instance in the Kigogo/Msimbazi area.

Thus, the Msimbazi river is heavily polluted due to the inflow of both industrial and domestic effluents from Vingunguti, Buguruni, Ilala, Kariakoo, Tabata, Kigogo, Magomeni, Mabibo, Mburahati, Manzese, Mwanayamala and Ubungo. The notorious effluent include dyes, strong alkalis from textiles, oil and tars from heavy vehicles, depots and power stations, organic wastes from breweries and meat plants, and various industrial wastes such as heavy metals, acids, pesticides, paints and other harmful chemicals from factories. The result is deleterious to the Msimbazi creek water quality and mangrove biota thus constituting a threat to public

health, especially for people walking through or around the area and cultivators of crops there.

The available evidence (admittedly scanty) suggests that both biological and chemical wastes cause oxygen depletion in the Msimbazi estuary. The chemically produced low-oxygen water from the Ubungo factories is mixed with the excess organic wastes from Tanzania Breweries and Muhimbili. The smell is an indication of the beginning of anaerobic conditions. The relative efficiency of the tidal flushing is probably the reason why the situation is not yet severe enough to cause a stench and a hazard to human health.

### Tanga

Tanga Municipality is certainly one of the nation's centres of manufacturing industries. It ranks fourth after Dar es Salaam, Mwanza and Morogoro. However, most of the establishments are of small to medium size if compared with the nation's other firms. The only large ones are the fertilizer plant, the cement factory at Pongwe, Amboni Plastics, Steel Rolling Mills, Dairies Ltd. and Forma Soap Factories in Tanga Town. If one classifies the existing industries according to their type of activity one would find that manufacturing is 58 per cent, processing 26 per cent, and servicing 6 per cent. The predominant sectors are food processing, metal works, wood-work, furniture making and soap making. The distribution of industries in the municipality is very uneven. Most of the big industries are located in the main industrial area near the airport except the three isolated industries of cement (Pongwe), fertilizer plant (Ras-kazone) and Amboni Plastics (along the Mombasa Road). A few others are dotted about other areas of the municipality especially in Ngamiani and along the Pangani Road.

In Tanga Region there is the Tanga fertilizer factory which is considered to have an adverse environmental impact. It started operation in 1972 and is owned jointly by National Chemical Industries and a company of the Federal Republic of Germany. It is situated in Tanga Town about 2 km east of the town centre and close to the sea. It is the biggest industry in Tanga with a total investment cost of more than T. Shs. 100 million. In relation to air pollution, the factory emits foul-smelling and irritating gaseous pollutants ( $SO_2$  and ammonia) which cause occasional nuisance to the inhabitants of the municipality. Regarding water pollution, gypsum, which is formed as a by-product, is discharged to the sea. In a small receiving body of water this could cause serious pollution problems through sedimentation of the gypsum slurry and leaching into the water of noxious trace contaminants and residual fertilizer compounds contained in the gypsum. In this factory, the waste water is discharged into the open sea where it is effectively dispersed and carried away by the currents. However, it is now planned to utilize the waste gypsum in the cement factory which has recently been commissioned in the Region. Generally, there is no comprehensive programme for a regular monitoring of the effluent from the factory. The number of permanent employees is 750, of whom about 400 are engaged in direct production. In normal operation the factory works in three shifts. It makes different fertilizer products for the domestic market, the major one being compound fertilizer (NPK), triple sulphur phosphate (TSP) and ammonia sulphate (AS). The textile factory (CIC) is now in operation and pretreatment of effluents is in effect.

### Mtwara/Lindi

These are the least industrialized regions in Tanzania. Low cash incomes, transport problems affecting both raw material supply and product distribution, and unreliable supply of electricity have restricted industrial development. Currently,

the major industries are cashew-nut processing factories and oil-seed mills in Lindi, which employ about 5,000 people. A gas/fertilizer project is planned for Lindi, depending on the successful exploitation of Songosongo gas.

#### Coast Region

The major industries are a cashew-nut processing factory and the motor vehicle assembly plant. Their contribution to pollution of the ocean is minimal and they are situated about 40 km away from the coastline.

### COASTAL AND INLAND HYDROPOWER AND WATER WORKS

Hydro-electricity generation, industrial and municipal water supplies and a considerable proportion of irrigation and fisheries are all related to rivers and should be regarded as major functions of river basins. Because of their intrinsic ecological integrity, river basins are the natural and ideally suited territorial units for investigating major ecological processes, the functioning of major components of ecosystems and interactions between water bodies and neighbouring terrestrial systems, as well as for undertaking multi-purpose programmes of socio-economic development. In order to achieve the possible optimum utilization of natural resources, such a territorial unit needs integrated and environmentally sound management of water resources and land use, including human settlements.

Inland water resources are abundant in Tanzania. Let us take, as an example, the Rufiji river basin which is the largest and most important, covering 177,000 km<sup>2</sup> or 20 per cent of the country, and receiving one third of the total national rainfall. It is centrally situated and contains only one major centre (Iringa): several others are located in close proximity to the border of the basin (Dar es Salaam, Dodoma, Morogoro, Mbeya). It extends 700 km from Mbeya in the west to the Indian ocean in the east. Land elevation ranges from 3000m down to sea-level with corresponding climate from temperate to tropical. Vegetation is generally of the savannah type with scattered trees and bushes which become denser in the vicinity of the rivers.

The Rufiji river is made up of the following tributaries (the proportions of the total run-off (at Stiegler's Gorge) and catchment areas are given for each):

Great Ruaha	15%	84 000 km <sup>2</sup>
Kilombero	62%	40 000 km <sup>2</sup>
Lwegu	18%	26 000 km <sup>2</sup>
Rufiji	5%	27 000 km <sup>2</sup>

On the basis of successful ventures undertaken by other countries the Government decided to establish the Rufiji Basin Development Authority (RUBADA) under the Ministry of Water and Energy. Specifically it is assigned the task of generating and supplying electricity by means of hydroworks and undertaking measures for flood control. Moreover it is responsible for promoting and regulating development activities in the basin in respect of agriculture, forestry, tourism, fisheries and communications.

The Government seeks to industrialize in order to diversify the economy so as to boost the low GNP which relies heavily on agriculture. Such industrial developments will require substantial amounts of electricity. There are also plans for supplying electricity to villages and urban centres.

As a renewable source of energy, hydropower offers considerable advantages. The Rufiji basin has the greatest concentration of potential major hydropower projects. Twenty major river development sites have been identified for grid power stations i.e. stations of above 50 MW installed capacity, with some 7,600 MW total hydropotential. Out of them eleven are located in the Rufiji basin totalling some 6,600 MW, 86 per cent of the whole potential. The biggest project is the Stiegler's Gorge power and flood control development which will be carried out in four phases aiming at 2,000 MW installed full capacity that will meet Tanzania's power demands up to the year 2010. Besides, it will provide flood control for downstream areas.

The most important activity carried out at present in the basin is agriculture. On the Great Ruaha river there are more than 200,000 hectares of irrigable land. Development of this area by village irrigation projects, and on a large scale, has already started and further irrigated farms are planned. In the Kilombero valley there are up to 300,000 hectares of irrigable land the development of which has been hampered by poor communications. RUBADA's activities in agriculture have been concentrated on the Lower Rufiji valley. A pilot project is being prepared for a proposed long-term development programme of 65,000 hectares of irrigation, combined with effective flood control.

Large areas of land are used as national parks and game reserves. The Selous and Rungwe Game Reserves, and the Ruaha and Mikumi National Parks are located in the basin, taking up more than 40 per cent of its area. The Selous Game Reserve is the largest in Africa and the second largest in the world. It covers 48,000 km<sup>2</sup>, more than double the size of Serengeti National Park and Ngorongoro Conservation Area together. It boasts some 700,000 large mammals including Africa's largest elephant, buffalo, hippopotamus and crocodile populations. Large mammal species total 36, there are over 350 bird species and probably in excess of 2,000 species of vascular plants. The 134 m dam of the Stiegler's Gorge project will create a reservoir of some 1,200 km<sup>2</sup> surface area, which will occupy about 3 per cent of the Selous Game Reserve, and will have little overall effect on its wildlife, although changes in the immediate area of the reservoir will occur.

The Rufiji basin has very great potentials for tourism development. Ruaha and Mikumi National Parks, and the Rungwa and Selous Game Reserves, offer a variety of important tourist attractions which include photographic safaris, walking safaris, river safaris, ornithological and botanical tours, fishing and hunting (in selected areas). Development of tourism in the Selous Game Reserve would be improved by the construction of an access road from Chalinze to Stiegler's Gorge.

The Rufiji basin is ideal for industrial forest plantations. Thus afforestation mainly with exotic species of pine and cypress trees is being intensively pursued in the Southern Highlands (Sao Hill) while black wattle plantations have been developed near Njombe. Afforestation in the lowlands include plantations of several species of fast-growing trees.

There is no doubt about the importance of fisheries. According to an estimate, fish, mainly freshwater species, provide more than 20 per cent of the protein in the diet of Tanzanians. Total estimates of fish catches from the Rufiji basin are not available but are known to be significant. Catches from the Kilombero basin alone amount to 14,000 tonnes. In the Lower Rufiji flood plain it is estimated that 5,600 tonnes of fish are caught annually. The Kidatu reservoir, though small and rather unproductive, can yield up to 140 tonnes. In the Mtera reservoir a stable annual yield of some 3,600 tonnes is expected. In the Rufiji Delta and Mafia Channel catches of fish and prawns amount annually to 1,800 and 700 tonnes, respectively.

There is still plenty of undeveloped fisheries potential in the Rufiji basin. The planned Stiegler's Gorge reservoir is expected to provide a stabilized annual catch of 3,700 tonnes. Several potential dam sites have been identified in the upper catchment areas of the Rufiji basin. Implementation of these projects could lead to the creation of several other man-made lakes where indigenous fish species may colonize new habitats, or exotic species may be introduced. Apart from capture fisheries, some areas of the Rufiji basin, particularly the Lower Rufiji flood plain and the Kilombero valley offer excellent sites for aquaculture.

As regards environmental impacts, the Mufindi pulp and paper mill, the Kilombero sugar industry and Iringa town, as well as the Lower Rufiji area, are critical in this respect. The Mufindi pulp and paper mill will become operational in 1987 and its processing water will be taken from the North Ruaha river. The treated effluent will be discharged into the same river, which, joined by several tributaries, passes on to the Kilombero flood plain. The average effluent load to the recipient river has been estimated as high as 80 mg/1 BOD<sub>5</sub> and 100 mg/1 total suspended solids. The potential effects of the mill are identified as a serious water pollution problem facing the fishing industry, and as an air pollution threat to the tea plantations. The water pollution might primarily affect the Kilombero flood plain fishery because of its proximity, some 100 km. It is also felt that the mill will affect fisheries in the planned Stiegler's Gorge reservoir. The reservoir is expected to trap, annually, more than 15 million tonnes of sediment contaminated with chlorinated organic toxins, which will enter the reservoir's food-chain. These chlorinated compounds accumulate in fish tissues, imparting an undesirable taste and odour; furthermore, at high concentrations they make the fish unpalatable and a threat to human health.

The Kilombero valley has considerable agricultural potential. Uncontrolled development of the area could adversely affect the hydrology and sediment load of the Kilombero river which provides 62 per cent of the flow at the proposed Stiegler's Gorge reservoir. The Kilombero swamps are important breeding areas for fish. Changes in ecology and water quality can be expected to result from agricultural, industrial and water development projects, and they can have a harmful effect on aquatic life.

The use of fertilizers in agriculture is still minimal, but herbicides, mainly ammonium sulphate, are already heavily used on the Kilombero sugar estate. Apart from the pollution caused by fertilizers and herbicides, waste products from the sugar industry are discharged into the Great Ruaha river. The major industrial wastes include filter cake (soil, wax, proteins, etc.) bagasse, caustic soda and molasses. Kilombero One has no effluent treatment system. The filter cake is usually dumped into the Great Ruaha river. In 1981, for example, approximately 8,500 tonnes of filter cake were disposed of in this way within 150 days, that is more than 56 t/day. Kilombero One has no problem with sewage disposal because pit latrines are used. Kilombero Two has oxidation ponds for biological treatment of mill effluents before they are discharged into the river. The efficiency of the treatment system is unknown because no information is available on details regarding the operation system (the volume of the oxidation ponds and the retention time). The filter cake is usually disposed of on farms as fertilizer. No information is available on the disposal system of sewage.

Molasses from both Kilombero One and Two are usually stored for export, but when storage facilities become unavailable the molasses is usually dumped in the Great Ruaha river. Thus, in 1981, some 830 tonnes from Kilombero Two alone were discharged into the river. Molasses being highly biodegradable, water deoxygenation down-stream is expected to be very persistent especially during the dry season when the water

volume in the recipient river is low. This situation is catastrophic to the aquatic fauna and wildlife using the river for watering. Large quantities of water are used for the cooling process. This water, though slightly polluted organically, is highly polluted thermally with temperatures of up to 40°C. Such hot water, if discharged directly into the river may render the habitat unsuitable for both flora and fauna. It is most unfortunate that to date there has been no programme to monitor the effect of the Kilombero sugar industry waste disposal on the environment. Recently, abnormal fish and other wildlife kills have been reported below the sugar estate.

In Iringa town, so far, the only important industries that can significantly affect the environment are the Dabaga Fruit Canning Industry, Cotex and SIDO, all of which are located in the Ruaha industrial area. Effluents from these industries are minimal and are usually discharged into the Little Ruaha river untreated.

According to the 20-year master plan, all industries must have oxidation ponds at the industrial site to treat their effluents before discharging them into the Little Ruaha river. A series of oxidation ponds are also being constructed near Kitwilu, the Ruaha industrial area, and will collect all the industrial wastes from the town for further treatment before discharging them into the Little Ruaha river. Separate oxidation ponds are also to be constructed near Mkwawa for treating the sewage from the whole town. The treated sewage will eventually be discharged into a nearby brook. The only problem with this is the capacity of the brook to absorb the discharged effluent which may still contain a considerable amount of BOD, and nutrients like nitrates, phosphorus, etc. These may affect the recipient waters and the environment as a whole significantly. The oxidation ponds planned near Mkwawa for treating domestic wastes are too near the town and after some years it is possible that they will be sandwiched by the town. The question of the capacity of the receiving brook to absorb the partially biologically treated refuse without being affected also needs further consideration.

The Lower Rufiji flood plains provide a potentially very rich crop growing region. Rice production at present depends on adequate flooding and consequent silt and nutrient deposition in the rains. Excessive flooding or no flooding can cause complete crop failure. The Stiegler's Gorge dam is intended to control these unpredictable floods for more efficient agricultural practices. The flood plain area potentially available for rice or other crops is in excess of 80,000 hectares and could enable Rufiji district to become a major granary for Tanzania. Flood water control, irrigation possibilities and loss of sediment and other effects consequent on river impoundment will need very careful evaluation for efficient production.

The lakes and swamps along the Lower Rufiji provide one of the finest wildlife spectacles in East Africa. The area is accessible to Dar es Salaam, has very high game and bird densities of exceptional variety and offers visitors opportunities of trips in vehicles, on foot or by boat, game watching and fishing. To a large extent the area is dependent on the flow of the Rufiji river through a maze of channels and swamps connecting the five major lakes. The Rufiji changed its dry season course in 1971 to flood lakes, thus creating new swamps and populations of elephant, buffalo and crocodile have greatly increased since then. In addition to the Selous lakes there are a number of small lakes adjacent to the Rufiji in the settled areas which do provide a fish resource.

The Rufiji Delta area of some 400 km<sup>2</sup> is currently exploited for rice cultivation, fishing and mangrove pole cutting. Mangrove poles build most of Dar es Salaam houses and have been a major export in the past. The delta has a considerable estuarine fishery and a potentially valuable offshore prawn industry. The area is biologically unknown and results from a complex system of fresh and salt water interaction and sediment and nutrient inputs.

Changes in the Rufiji water regime could be expected to alter the ecology and level of resources of the whole delta. In any case, the envisaged loss of fish catches in the flood plain will be substituted by catches from the reservoir. Based on the relationship between mangrove area and prawn production, and assuming that the dam construction is likely to lead to a reduction of mangrove area of a little more than 10 per cent, loss in the potential prawn yield will be under 10 per cent.

The creation of man-made lakes, mainly the Stiegler's Gorge project, may have negative effect on health due to the increased potential for disease vectors in the reservoir area, especially the potential incidence of schistosomiasis, malaria and filariasis in the future irrigation scheme in the flood plain. Disease vectors in the reservoir can be controlled by maintaining an appropriate reservoir level while, in the down-stream area they can be controlled by an appropriate release pattern. The potential incidence of the diseases in the future perennial irrigation scheme in the flood plain can be controlled more or less successfully by specific measures (chemicals, specific construction or operating measures).

Average monthly discharge and sediment load of  
River Rufiji at Stiegler's Gorge (1958/59)

Month	Discharge (m <sup>3</sup> /sec)	Silt load (tonnes)
November	3,640	7,000
December	6,660	3,059,000
January	18,500	2,517,000
February	34,850	3,599,000
March	44,900	4,786,000
April	68,500	1,215,000
May	58,100	432,000
June	28,150	121,000
July	16,320	47,000
August	11,200	48,000
September	7,870	12,000
October	5,450	1,500
Total	304,140	15,858,000

TRANSPORT

Coast and Dar es Salaam Regions

Dar es Salaam has good connections by sea, air and rail.

Roads

There are a number of trunk roads starting from Dar es Salaam. These include:

The TANZAM road which goes to Zambia and carries Zambia-bound traffic;

- The central trunk road which runs from Dar es Salaam, Mwanza to Bukoba and Kigoma via Dodoma;
- The trunk road from Dar es Salaam to Moshi-Arusha via Korogwe.

The Dar es Salaam - Kibiti is an existing tarmac road ranked as a trunk road. From Kibiti to Nyamwage (48 km) there is a poor track which involves crossing the Rufiji River by ferry at Ndundu. Nyamwage - Nangurukuru 25 km west of Kilwa Kivinje covers about 100 km. Then the Nangurukuru - Lindi section. The construction of this road is discussed in the Third Five-Year Plan for upgrading to murrum standard as well as the road between Kibiti to Nyamwage and Lindi to make it all-weather. It is proposed that this road be tarmacadamized between 1985/86 and 1995.

However, there are proposals to construct a road from Dar es Salaam to Chalinze-Stigo. This is intended to be phased; the Dar es Salaam - Chalinze section is the existing tarmac road, part of the Dar es Salaam - Morogoro road. The Chalinze - Stigo section is in existence as a seasonal track and is intended to be upgraded in the long run to be a tarred road. Nevertheless the road is to enable the construction of the Stigo dam and it is therefore subject to the decision to construct the dam.

Most of these trunk roads carry goods destined to and from land-locked countries like Rwanda and Burundi, and also Zaire and (to some extent) Zambia and Malawi. Part of the goods traffic is ferried by rail (TAZARA for Zambia-bound traffic) and the central line (for Rwanda, Burundi, Zaire).

#### Railways

There is a railway terminal at Dar es Salaam only.

#### Airways

There is an international airport at Dar es Salaam and other airports at Mafia, Lindi, Kilwa, Nachingwea and Mtwara.

#### Airport services in Tanzania (five months' operations only)

	No. of landings	Em-barked	Passengers Disembarked	Loaded	Unloaded	Freight (kg) Un-loaded	Mail (kg) loaded
Dar es Salaam	4,419	60,296	79,535	633,000	77,000	307,000	96,000
Tanga	460	3,932	5,932	5,775	13,334	44,076	4,088
Lindi	263	2,814	2,976	4,591	9,711	20,617	4,459
Mtwara	483	5,542	6,512	19,668	15,436	53,508	6,769
Nachingwea	180	523	858	2,597	1,659	19,462	610
Kilwa	82	415	352	1	160	1,585	138
Mafia	426	2,583	2,825	2,028	742	7,028	474

(Source: Air Tanzania Corporation 1978)

#### Ports

Dar es Salaam port is the second largest of the four major East African sea ports of Mombasa, Tanga and Mtwara. Dar es Salaam handles 97 per cent of Tanzania's



oil traffic and 80 per cent of the nation's general cargo trade. It is also the leading passenger port and a naval base. The port has traditionally handled transit traffic for Zaire and the land-locked countries of Burundi and Rwanda. Today, it has also become a major avenue for Zambia's seaborne imports and exports, a role which will be of increasing importance in the future.

(a) Data (1972) (Dar es Salaam)

The port handled 1,540,000 tonnes of dry cargo comprising 916,000 tonnes of imports and 624,000 tonnes of exports, together with 1,284,000 tonnes of bulk oil of which 709,000 tonnes were crude oil imports.

Of total dry cargo tonnage, transit cargo for Zaire, Burundi and Rwanda accounted for about 6 per cent of imports and about 20 per cent of exports. Zambia transit dry cargo during 1972 represented just under 11 per cent of total imports and about 35 per cent of exports.

The average size of ship calling at Dar es Salaam during 1972 was 10,000 dead weight tonnage (dwt) with the majority of vessels being the conventional general-cargo type.

(b) Projections for Dar es Salaam

The volume of long-term traffic will be dependent on development of the port's hinterland and upon improvement in transport technology.

Barring any spectacular technological developments in other forms of transport, sea transport is likely to remain the cheapest for foreign trade. The port will therefore be required to handle vastly increased quantities of goods.

(c) Potential traffic for Dar es Salaam Port

The hinterland of Dar es Salaam has vast agricultural potential. It is therefore possible to conceive of large-scale exports of good grains as well as meat and dairy produce over a longer time-scale. To enable these agricultural developments to be realized there might have to be large-scale imports of fertilizers or their raw materials.

Mineral resources potential is also good. Proved coal and iron ore deposits in Tanzania could well be exploited in the not too distant future as world fuel costs rise. The development of these basic resources could trigger large-scale industrial activity and in turn these possible developments could generate substantial port traffic.

(d) Data forecasts

The forecasts predict a port throughput for 1990 of 4,013 million tonnes of general cargo and 4.28 million tonnes of bulk oils.

A major feature of the traffic forecasts is the expectation that, as soon as new port and inland transport facilities are developed, Dar es Salaam will become Zambia's principal seaport. The forecast for 1980 was that some 52 per cent of traffic through the port would be Zambian traffic.

Non-Zambian traffic is forecast to increase from 2.11 million tonnes (in 1975) to 4.25 million tonnes in 1990 at an average annual growth rate of 4.8 per cent.

Dar es Salaam general cargo traffic, 1960-1990 (thousand tonnes)

	1960	1965	1970	1975 <sup>a/</sup>	1980 <sup>a/</sup>	1985 <sup>a/</sup>	1990 <sup>a/</sup>
<b>Imports</b>							
Tanzania, Zaire, Burundi, Rwanda, Zambia	243	376	677	483	513	678	855
	-	-	155	804	932	1,081	1,255
<b>T o t a l</b>	<b>243</b>	<b>376</b>	<b>832</b>	<b>1,287</b>	<b>1,445</b>	<b>1,759</b>	<b>2,108</b>
<b>Exports</b>							
Tanzania, Burundi	357	287	351	372	584	737	940
Zaire, copper	-	21	100	116	134	156	181
Zambia, copper	-	-	263	553	610	674	744
Zambia, lead + zinc	-	-	-	80	100	100	100
Zambia, other exports	-	-	-	10	25	40	60
<b>Total exports</b>	<b>357</b>	<b>308</b>	<b>714</b>	<b>1,131</b>	<b>1,453</b>	<b>1,707</b>	<b>2,025</b>

Bulk petroleum oil traffic

	1960	1965	1970	1975 <sup>a/</sup>	1980 <sup>a/</sup>	1985 <sup>a/</sup>	1990 <sup>a/</sup>
<b>Imports</b>							
Tanzania (crude & products)	239	253	1,022	900	1,200	1,650	1,900
Zambia (crude)	-	-	-	950	1,200	1,550	2,000
<b>T o t a l</b>	<b>239</b>	<b>253</b>	<b>1,022<sup>b/</sup></b>	<b>1,850</b>	<b>2,400</b>	<b>3,200</b>	<b>3,900</b>
<b>Exports</b>							
Tanzania <sup>c/</sup>	-	2	141	235	195	460	375

<sup>a/</sup> Potential traffic assuming port and inland transport facilities

<sup>b/</sup> Tanzania figure includes crude oil for Zambia refined at Dar es Salaam

<sup>c/</sup> Residual oils, bunker oils, and coastal products

(Source: Dar es Salaam Port Development Study, Vol. 1 (Main Report) 1975)

Recommendations (1990 and beyond)

The entrance channel should be straightened and deepened to minus 10 m. With improved navigation aids this will enable ships to move at night and most of the vessels now using the port will be able to move at any state of tide, while vessels of 35,000 will be able to move at high water.

Two further berths should be constructed, after berths 9 to 11 are complete, and a new oil jetty.

### Increase efficiency of cargo handling

Construction of rail depots for TAZARA and Tanzania Railway Corporation (TRC) on sites outside the port operational area, so that traffic for Zambia or for Zaire, Burundi and Rwanda can normally be carried from the transit shed by road vehicles.

Ecological studies show that there will be no serious environment problems in the recommended works. It is, however, considered important that dredged material should be dumped further offshore than at present to avoid irreplaceable damage to coral reefs over a considerable length of coastline. Pollution of the harbour due to increased shipping makes it advisable to stop the discharge into the harbour of land-based sewage and industrial effluents.

### Coastal trade

At present, there is little trade and it is confined to the southern regions of Tanzania. This is primarily because of the poor road communications (there is no rail link) to these areas. Should the land communications be developed (and this would appear to be a likely occurrence as schemes have already been worked out) coastal shipping can be expected to play a much smaller role in the longer term.

In Tanzania the coastal shipping service is managed by the Tanzania Coastal Shipping Lines (TACOSHILL). The company owns three vessels which are generally meant for cargo (e.g. food stuffs, building materials and agricultural products). TACOSHILL operates a weekly service using 550 - 600t vessels. This is the main large-capacity freight and passenger link at present between Dar es Salaam and South-east Tanzania (Lindi and Mtwara). Nevertheless, its carrying capacity is insufficient and there are frequently long delays in loading goods stored in Dar es Salaam in the TACOSHILL'S godown for shipment to Mtwara and Lindi. As with most ports, passenger traffic is dwindling due to the increasing use of air transport.

## Tanga Region

### Roads

There is an all-weather road from Tanga to Mkwaja via Pangani and another road of poor standard to Bagamoyo.

There is a trunk route from Tanga to the Kenya border via Duga. It is also linked with a branch of the West North Road to Moshi Arusha - Namanga Nairobi. This trunk road to Tanga branches at Korogwe.

### Railways

There is a railway line from Dar es Salaam to Tanga via Korogwe. This railway line to Tanga is part of the line from Dar es Salaam to Tanga and Arusha. It is operated by the Tanzania Railways Corporation.

Local-passenger and goods traffic handled at Tanga station

Year	Passenger traffic		Goods traffic (kg)		Parcels (kg)		Luggage (kg)	
	In	Out	In	Out	In	Out	In	Out
1978		37,178			7,240	10,512		152
1979		49,590	25,249	15,115	132,917	434,338	43,443	119,648
1980		59,965	50,164	43,824	223,540	405,422	28,201	163,899
1981			40,850	39,970				

(Source: TRC, Tanga Station)

Ports and harbour

Tanga has a good natural harbour but it has no deep-water berths; lighters are used to transport goods to and from the shore. The port, administered by Tanzania Harbours Authority, has a nominal rated capacity of about 320,000t/y but is not usually used to full capacity (in 1973, for instance, it handled only 280,000t). There is a provision for two, parallel deep-water berths either in the inner harbour or at Mwambani Bay near the new site facing the sea. This development is not likely before 1988, unless traffic is diverted from Dar es Salaam and Mombasa.

An additional multi-purpose jetty outside the harbour area was completed in 1971 to supply the fertilizer factory with raw materials. It is recommended that oil products traffic should be transferred to this jetty.

Exports have been dominated by sisal traffic but in recent years coffee has developed and is forecast to overtake sisal in the future. The projects of Uganda or Rwanda traffic depend on the construction of the Arusha - Musoma rail link.

Total export and import traffic handled at Tanga rose from 202,000t in 1960 to 396,000t in 1974 and 380,000t in 1975 showing an average growth rate of 4.30 per cent per annum from 1960 to 1975. The underlying growth in traditional port traffic was, however, very much lower, since traffic in 1974 and 1975 included large tonnages of food imports (maize, wheat and rice) made necessary by crop failures and of other traffic to and from northern Tanzania (including coffee exports in particular) which formerly used to pass through Mombasa.

The prime reason for this slow growth in overall traffic through the port has been the decline, particularly since 1970, in shipments of sisal averaging about 125,000t/y in the ten-year period 1960-69 and reaching 148,000 in the good year 1970 but declining steadily to a level of only 74,000t in 1975. Meanwhile total exports, which averaged 160,000t between 1960 and 1969 declined to 131,000t in 1973 but rose again to 162,000t in 1974 due to the diversion to Tanga of Tanzania coffee previously shipped through Mombasa.

Tanga imports were 45,000t in 1960 and the 1973 level of 87,000t (excluding fertilizer inputs) showed an average annual increase since 1960 of 5.2 per cent. By the end of 1975 Tanzania imports previously passing through Mombasa had generally been diverted to Tanga. Total Tanga imports, excluding relief grain in that year were 124,000t.

### Pangani

Formerly used as a harbour because the mouth of the Pangani river offers some natural protection. Nowadays it is used only by small dhows and as a fishing port. The same is true of Moa near the Kenya border.

### Mtwara Region

The Region suffers from its inaccessibility from the more developed central, northern and south-western areas of the country. Lack of adequate road transport communications either to the north or to the south-west has hampered the regions development. Poor maintenance of the existing regional roads has also been a constraint. Thus neither road nor sea transport capacity has increased. Both road freight and passenger capacity have declined, the latter very markedly.

#### Roads

One asphalt road from Mtwara town crosses the regional border and continues to Lindi town. The total distance is about 105 km. The remainder of this road which eventually leads to Dar es Salaam, is unpaved except for a stretch of 120 km between Kibiti and Dar es Salaam. For most of the December-May rainy season the ferry across the Rufiji River does not operate, making the road impassable despite its national importance as a link between the rest of the country and the South. The second asphalt road links Mtwara and Masasi towns leaving Mtwara - Lindi at Mingoyo and passing some 120 km through northern Mtwara and southern Lindi regions.

#### Air Transport

There are three return Air Tanzania Corporation flights per week between Mtwara town and Dar es Salaam. It is barely adequate to fulfil Mtwara passenger demand. The capacity of each plane is 106 passengers. The air services have only limited freight capacity and they are too expensive to provide any kind of substitute for shipping and trucking.

#### Harbour

Mtwara port has the potential of being a major harbour if it can be developed to serve land-locked countries like Zambia, Malawi, etc. However, the prospects for this port are directly related to the economic growth of the region.

### Lindi Region

Roads (see description of Mtwara roads)

#### Harbour

In the absence of adequate road communications the coastal sea route is the most important freight link. The region is served by small port facilities at Kilwa, Masoko and Lindi. TACOSHILL operate a weekly service between Dar es Salaam and both Lindi and Mtwara using two 500 - 600t vessels. A small amount of cargo is also carried by coastal schooner.

Coastal shipping traffic 1979-1980

From Dar es Salaam to:	Kilwa	Lindi	Mtwara
Foodstuffs	1,200	5,600	7,000
Building materials	500	2,800	3,600
Other	1,200	5,600	7,000
<b>T o t a l</b>	<b>2,900</b>	<b>14,000</b>	<b>17,600</b>

To Dar es Salaam from:	Kilwa	Lindi	Mtwara
Agricultural products	900	3,000	12,000
Other	100	400	1,300
<b>T o t a l</b>	<b>1,000</b>	<b>3,400</b>	<b>13,400</b>

Air transport

Currently suspended; normally, there is a weekly service to Lindi.

Impact of transport on the ecosystem

The increased shipping activity along the coast and in the harbours, dredging the harbour channel, handling of petroleum tankers and oil spillages in ports are bound to have minor environmental consequences, in particular possible damage to coral reefs due to the dumping of dredged spoil.

Passenger movements at principal mainland ports

Year	Dar es Salaam		Tanga		Mtwara	
	Disembarked	Embarked	Disembarked	Embarked	Disembarked	Embarked
1973	28,863	33,192	305	69	4,806	4,850
1974	23,947	24,011	78	2	6,377	5,415
1975	21,873	27,145	259	-	13,216	16,213
1976	17,949	21,495	242	373	9,797	7,816
1977	23,581	22,691	1,890	1,847	6,112	5,068
1978	13,859	14,489	-	172	4,140	3,781
1979	14,030	11,568	-	227	6,331	8,856

(Source: Tanzania Harbours Authority)

Tanzania mainland ports - Number of vessels entered

Year	S T E A M S H I P S					Total	Sailing ships	Total shipping
	Dar es Salaam	Tanga	Mtwara	Lindi	Other ports			
1973	991	379	185	16	-	1,571	120	1,691
1974	965	377	190	17	-	1,526	96	1,622
1975	1,017	379	198	83	-	1,677	60	1,737
1976	1,033	390	163	-	-	1,586	247	1,833
1977	1,077	407	124	-	-	1,608	1,597	3,205
1978	957	417	105	-	-	1,479	1,815	3,294
1979	850	327	121	54	58	1,410	2,154	3,560

(Source: Tanzania Harbours Authority, Monthly Shipping Statistics Return)

Tanzania mainland ports: Net registered tonnage entered  
(thousand tons)

Year	S T E A M S H I P S					Total	Sailing ships	Total shippi
	Dar es Salaam	Tanga	Mtwara	Lindi	Other ports			
1973	3,687	1,492	295	-	-	5,474	-	5,474
1974	3,362	1,388	293	-	-	5,043	-	5,043
1975	3,835	1,505	255	-	-	5,595	-	5,595
1976	4,164	1,619	223	-	-	6,006	-	6,006
1977	4,244	1,698	222	-	-	6,164	-	6,164
1978	3,887	1,856	235	-	-	5,978	-	5,978
1979	3,651	1,517	234	24	-	5,426	-	5,426

(Source: Tanzania Harbours Authority, Monthly Shipping Statistics Return)

Shipping statistics at Tanzania mainland principal ports <sup>a/</sup>

I T E M	Unit	1973	1974	1975	1976	1977	1978	1979
Total number of ships	Number	1,555	1,512	1,594	1,586	1,608	1,479	1,298
Net registered tonnage (NRT)	'000'	5,474	5,043	5,595	6,006	6,164	5,978	5,402
Total passengers <sup>b/</sup>	Number	72,085	59,830	78,706	57,672	61,189	36,441	41,012
Cargo handled:								
Unloaded (total)	'000' dwt	-	3,173	3,296	3,150	3,457	3,363	2,671
- Dry general cargo	'000' dwt	970	1,421	1,217	1,468	1,413	1,064	1,356
- Bulk fertilizer	'000' dwt	-	105	51	65	51	45	33
- Bulk cement	'000' dwt	-	11	8	-	-	-	-
- Bulk oil (petroleum products)	'000' dwt	1,633	1,744	1,816	1,865	1,931	1,901	1,569
- Bulk oil (other)	'000' dwt	-	-	-	3	2	4	5
Loaded (total)	'000' dwt	1,059	1,110	1,144	1,633	1,492	1,337	1,154
- Dry general cargo	'000' dwt	-	861	948	1,374	1,269	1,185	1,017
- Bulk oil including bunkers (petrol)	'000' dwt	-	249	196	249	217	135	124
- Molasses	'000' dwt	-	-	-	10	6	17	13
Transhipment	'000' dwt	3	8	3	8	3	2	1
Total cargo handled	'000, dwt	-	4,291	4,443	4,791	4,952	4,702	3,826

a/ The ports of Dar es Salaam, Tanga and Mtwara  
b/ Includes embarked and disembarked passengers

(Source: Tanzania Harbours Authority)



Shipping statistics: Dar es Salaam port

I T E M	Unit	1973	1974	1975	1976	1977	1978	1979
Total number of ships	Number	991	965	1,017	1,033	1,077	957	850
Net registered tonnage (NRT)	'000'	3,687	3,362	3,835	4,164	4,244	3,887	3,651
Total passengers <sup>a/</sup>	Number	62,055	47,958	49,018	39,444	46,272	28,348	25,598
Cargo handled:								
Unloaded (total)	'000' dwt	2,392	2,842	3,006	2,887	3,195	3,068	2,457
- Dry general cargo	'000' dwt	796	1,144	1,231	1,066	1,299	1,206	915
- Bulk fertilizer	'000' dwt	-	-	-	-	-	-	-
- Bulk cement	'000' dwt	-	-	3	-	-	-	-
- Bulk oil (petroleum products)	'000' dwt	1,596	1,698	1,772	1,818	1,892	1,858	1,537
- Bulk oil (other)	'000' dwt	-	-	-	3	2	4	5
Loaded (total)	'000' dwt	820	849	880	1,378	1,268	1,065	896
- Dry general cargo	'000' dwt	-	600	684	1,119	1,045	913	759
- Bulk oil including bunkers (petrol)	'000' dwt	-	149	196	249	217	135	124
- Molasses	'000' dwt	-	-	-	10	6	11	13
Transhipment	'000' dwt	2	6	2	2	3	1	1
Total cargo handled	'000' dwt	3,212	3,697	3,888	4,267	4,454	4,134	3,354

<sup>a/</sup> Includes embarked and disembarked passengers

(Source: Tanzania Harbours Authority)

Shipping statistics: Tanga port

I T E M	Unit	1973	1974	1975	1976	1977	1978	1979
Total number of ships	Number	379	377	379	390	407	417	327
Net registered tonnage (NRT)	'000'	1,492	1,388	1,505	1,619	1,698	1,856	1,517
Total passengers <sup>a/</sup>	Number	374	80	259	615	3,737	172	227
Cargo handled:								
Unloaded (total)								
- Dry general cargo	'000' dwt	-	253	218	177	185	236	168
- Bulk fertilizer <sup>b/</sup>	'000' dwt	127	122	141	89	111	165	113
- Bulk cement	'000' dwt	-	105	51	65	51	45	33
- Bulk oil (petroleum products)	'000' dwt	-	-	-	-	-	-	-
	'000' dwt	21	26	26	23	23	26	22
Loaded (total)								
- Dry general cargo	'000' dwt	131	142	162	175	139	166	192
- Bulk oil & bunker (petrol)	'000' dwt	-	142	162	175	139	166	192
- Molasses	'000' dwt	-	-	-	-	-	-	-
Transshipment	'000' dwt	1	-	1	-	-	1	-
Total cargo handled	'000' dwt	-	395	381	352	324	403	360

a/ Includes embarked and disembarked passengers  
b/ This is handled at a special jetty at Tanga port

(Source: Tanzania Harbours Authority)

Shipping statistics: Mtwara port

I T E M	Unit	1973	1974	1975	1976	1977	1978	1970
Total number of ships	Number	185	190	198	163	124	105	121
Net registered tonnage (NRT)	'000'	295	293	255	223	222	235	234
Total passengers <sup>a/</sup>	Number	9,656	11,792	29,429	17,613	11,180	7,921	15,187
Cargo handled:								
Unloaded (total)	'000' dwt	-	78	72	86	79	59	46
- Dry general cargo	'000' dwt	47	47	49	62	58	42	36
- Bulk fertilizer	'000' dwt	-	-	-	-	-	-	-
- Bulk cement	'000' dwt	-	11	5	-	-	-	-
- Bulk oil (petroleum products)	'000' dwt	16	20	18	24	21	17	10
- Bulk oil (other)	'000' dwt	-	-	-	-	-	-	-
Loaded (total)	'000' dwt	108	119	102	80	85	106	66
- Dry general cargo	'000' dwt	-	119	102	80	85	106	66
- Bulk oil including bunker (petrol)	'000' dwt	-	-	-	-	-	-	-
- Molasses	'000' dwt	-	-	-	-	-	-	-
Transshipment	'000' dwt	-	2	-	6	-	-	-
Total cargo handled	'000' dwt	171	199	174	172	164	165	112

<sup>a/</sup> Includes embarked and disembarked passengers

(Source: Tanzania Harbours Authority)

EXPLOITATION OF TERRESTRIAL BIOLOGICAL RESOURCES  
(INCLUDING AGRICULTURE AND ANIMAL FARMING)

Mangroves

Mangrove ecosystems constitute a valuable resource which, over the years, has contributed in several ways to the economy and fishery of many coastal peoples of the Indian Ocean region (MacNae, 1974). Available accounts of the uses of mangrove habitats in East Africa indicate that mangrove poles and mangrove tannin extracts were very valuable trade items during the early part of this century (Sheriff, 1971).

Mangroves are scattered all along the coast of Tanzania stretching from Tanga to Mtwara. The areas covered with mangroves vary between 500 km<sup>2</sup> and over 1,000 km<sup>2</sup>. All areas with mangroves were declared and categorized by the Government as 'reserves' in 1961 after it realized how this resource was threatened and could be jeopardized due to conflict in land use. Whereas exploitation is one of the most direct and easily identified of the problems, the negative impacts of pollution are indirect and rather unpredictable. If the resources of the mangrove ecosystems are to be available and significant in the future, they must be managed, and management problems have to be identified.

In Tanzania, three regions that have extensive mangrove forests include an area in the south near Kilwa and another in the Rufiji delta and also an area in the north near Tanga. The Rufiji delta covers an area over 500 km<sup>2</sup> and is the largest single mangrove stand on the eastern coast of Africa (Macnae, 1974). Smaller stands are found over the entire Tanzanian coast in estuaries, deltas and sheltered shores.

Estimates of mangrove habitats in Tanzania:

Area (km <sup>2</sup> )	Sources
789	Kileo (1972)
820	FAO/IOP (1979)
500 (for Rufiji delta only)	Sandberg (1974)
1100	Dorsey (1979)
1000	Anonymous (1981)

Traditionally the mangroves of Tanzania have been used as sources of building poles. The importance of mangrove poles as building material was recorded as far back as the 1930s. Today mangrove poles are still very important for local housing and some poles are even being exported to Zanzibar and the Middle-East (Iran and Dubai). For 1979 alone, 30,000 scores (1 score = 20 poles) were exported, two thirds of which were destined for Iran (Havnevid, 1980).

However, it is rather difficult to obtain estimates of the exact annual harvest for the purposes of domestic use and export because of illegal exploitation. But in the case of the coastal region (in particular Baganoyo, Kisarawe, Rufiji and Mafia districts) records of the exploitation of this resource are as follows:

1976	7,860.00 scores
1977	7,295.25 scores
1978	3,183.10 scores
1979	5,443.60 scores
1980	20,829.00 scores
1981	32,318.00 scores
1982	7,641.50 scores

Salt production from coastal areas covered by mangroves has been practised for a long time (Sutton, 1973), but it is only recently that extensive clearing of mangroves has been carried out to give way to salt evaporation pans. The increase in demand for table salt in Tanzania is bound to produce a corresponding decline in mangrove habitats. For example, in 1980 the total salt production in Tanzania was about 60,000 tonnes per year. It was planned to raise the total salt production to 170,000 tonnes per year by the end of 1981 with 100,000 tonnes to be produced from coastal evaporation pans and the remaining 70,000 tonnes from inland salt mines at Uvinza. The salt production activities are threatening to remove the small mangrove stands in the neighbourhood of Dar es Salaam, Tanga and Mtwara. For instance, a large mangrove forest area at Kunduchi has already been reduced by over 50 per cent by salt works. If this development is not checked the mangrove forests at Kunduchi will soon disappear altogether.

Deltas and estuaries at the mouths of large rivers are today threatened by development programmes of river basins. For example, the Rufiji delta with its large, unexploited stand of mangroves is now in danger due to construction of the Stiegler's Gorge dam 192 km upstream. Experience from dam building in other countries, e.g. Kenya and Egypt, have shown that such river basin developments may lead to dangerous problems downstream. It is expected that after the Stiegler's Gorge dam has been built there will be less silt deposited at the delta, so there may be increased beach erosion, and the decreased and regulated water flow will lead to sea-water wedge penetration further inland, and consequent destruction of the mangrove forest of the delta.

Generally it can be said that there is still need for stricter control over exploitation of this resource. The forestry division in the Ministry of Natural Resources and Tourism has the responsibility for the maintenance of these reserves and control of exploitation. Shortage of staff, lack of transport and support facilities have severely limited the division's ability to carry out these tasks.

### Agriculture

Tanzania is a predominantly agricultural country. The socio-economic development of the country in general and of its people in particular hinges on the development of agricultural and agro-based production. Over 90 per cent of the population is in one way or another involved in agriculture.

The agricultural sector has shown an overall upward trend over the last two decades. From Shs. 2,954 million in 1967 the agricultural GDP increased (at constant 1966 prices) to Shs. 5,143 million in 1980. The average annual rates of growth in real terms over the periods 1967 to 1969, 1969 to 1976 and 1976 to 1980 was 2.1, 3.8 and 5.6 respectively. In terms of agriculture's contribution to total GNP, the sector showed a decline between 1967 (42 per cent) and 1974 (39 per cent) and then picked up again in 1981 (50 per cent).

Like the rest of Tanzania the coastal area is basically agricultural. The major crops cultivated in practically all the coastal regions are cassava, maize, sorghum, banana and paddy. The cashew-nut crop is also produced by smallholders, mostly concentrated along the coastal belt from Mtwara to Tanga. 80 per cent of the crop, however, is produced in Mtwara and Lindi Regions. On the other hand, sisal is an estate crop, with a very insignificant smallholder participation, that is grown in almost all coastal regions. Along the coastal belt, tea and coffee are grown in Tanga Region only, while cotton is planted both in Tanga and Coast Regions. Due to excessive cutting of trees and other vegetation to clear areas for farming, in combination with inappropriate cultivation measures, considerable harm has already been done to the ecological balance in relation to lack of water and soil fertility.

### Sheep

Like goats these animals can be found all over the country. According to the 1978 census there were about 3.6 million of them. Nevertheless, very little has been done to improve the stock. In the coastal area, the total number of sheep is about 200,000. The breakdown by region is as follows:

Tanga	169,090 head
Coast	5,282 head
Lindi	3,600 head
Mtwara	8,977 head

In this belt, particularly in Mtwara and Lindi, there is a low level of fish and livestock production, which means a low consumption of animal protein per capita. It is estimated, for instance, that in Mtwara about 4.0 kg of protein is consumed annually per person:

Fish	2.7 kg
Livestock products	1.2 kg
Game	0.1 kg

### Pesticides and chemical fertilizers

Tanzania does not have a national policy defining and directing the use of fertilizers and other chemicals utilized to improve the yield and protect plants and crops. Thus, although the use of pesticides, insecticides, fungicides and herbicides is necessary to safeguard crop yields and quality, there have been heavy losses due to improper use.

The demand for fertilizers has been increasing over the past 10 years. Tanzania Fertilizer Company in Tanga manufactures only 72 per cent of fertilizers used in the country. The following table shows the amount of various fertilizers distributed throughout the country since 1973.

Year	Amount (tonnes)
1973	66,370
1974	82,570
1975	92,565
1976	70,357
1977	84,817
1978	82,274
1979	93,704
1980	107,091
1981	96,570
1982	81,910 (Projected)

(Source: Ministry of Agriculture)

The system of traditional agriculture characteristic of many developing nations, including Tanzania, is beginning to give way to modern agricultural practices. Traditional farming is claimed to be less exposed to endemic plant pests and plant diseases than are modern monoculture practices. Modern agricultural practices are more capital intensive in order to maximize production. Therefore, in the absence of crop protection measures, the anticipated crop yields will not be reached.

## Livestock

### Cattle

Tanzania has a total cattle population of about 12.49 million (according to the 1978 census), the third largest in black Africa after Ethiopia and Sudan. The biggest concentration is found outside the coastal belt in Arusha, Shinyanga, Mwanza, Mara, Tabora and Dodoma Regions. These are drought-stricken regions where cattle are mostly owned by pastoralists and semi-pastoralists. Over 60 per cent of the National herd is grazed on traditional rangeland which is 10 per cent of the total area of Tanzania.

In the coastal region, a considerable area, where natural conditions do not allow cultivation of crops, is used for livestock production and supports only 700,000 cattle. The breakdown by regions is as follows:

Tanga	556,278 head
Coast	106,628 head
Lindi	6,800 head
Mtwara	14,737 head

From the above statistics it can be seen that Tanga and Coast Regions have the larger numbers of cattle and it is only in these regions that a problem of overstocking is arising. In the coastal region the problem is aggravated by frequent immigration of nomadic pastoralists who come from up-country for pasture or are in transit to other areas. When man keeps many poorly managed animals they overgraze the range causing deterioration of the vegetation and ultimately the loss of soil cover, thus permitting soil erosion which is characteristic of overgrazing.

On the other hand, the number of cattle in Mtwara and Lindi is low. Ownership is restricted to a minority of households. It is observed that cattle do not thrive well in these regions because of tsetse infestation and lack of savanna type of vegetation (vegetation here is invariably very dense). Thus, the combination of climate, lack of suitable grazing land and limited water supplies, together with high tsetse infestation, mean that expansion of livestock, particularly cattle, in these two regions will continue to be difficult.

### Goats

Goats are hardy animals found nearly everywhere in Tanzania. There are about 5.8 million goats in the country (1978 census) whose economic importance lies in the supply of meat for local consumption and skins for export.

The coastal belt has about 400,000 goats and their numbers by region is as follows:

Tanga	305,481 head
Coast	21,020 head
Lindi	7,000 head
Mtwara	57,152 head

In Mtwara and Lindi, it has been observed that goats are well suited to local conditions since they are disease-resistant. Thus, it is intended to promote goat production by increasing its distribution and extending breed improvement and multiplication programmes.

In Tanzania pesticides and other chemicals are mainly used in large and State farms rather than in smallholdings. However, as the peasants are being encouraged to expand their farms as well as modernize their practices, more agrochemicals in the shape of fertilizers and pesticides are finding their way into the environment. The situation may be expected to become more serious because of abuses, misuse and lack of safety rules and general education on their use.

In the coastal belt, fertilizers and pesticides are being heavily used. According to available statistics, the actual application of agrochemicals in 1982 - 1983 was as follows:

Artificial fertilizers:	1,118.52	tonnes
Pesticides - liquid:	14,210	litres
- powder:	40,550	kg
Herbicides	66,021	litres

(Source: Ministry of Agriculture)

Undoubtedly, agrochemicals are being used at an increasing rate in agriculture.



REGION	Artificial fertilizer	Active ingredient %	Quantity (tonnes)	Pesticides	Active ingredient	Quantity of liquid (l)	Quantity of powder (kg)	Herbicides of liquid (l)	Quantity of liquid (l)
Dar es Salaam Coast	Ammonium sulphate (S/A) (Round-up)	21	451	Didimec Kynakil	5 1	1,000	2,000	Primagram Lasso (Atrazine)	2,100 700
	Triple sulphur phosphate (TSP)	46	70	Dimethoate DDT	40 25	700	550	Gramoxone 2,4-D	321 10,000
	Calcium ammonium nitrate (CAN) Gesaprin	20 600	190	Aladrin Endosulphor	40 35	1,000	33,000	Stam F34 Stam F34T	15,000 5,000
	S/A	21	20	Rotak Dithane		610	800	Avirosan Galex Agral 90	800 600 500
Tanga	TSP	46	93	Cypermethrin	2.5	800	200	Arelon Quelea fox	1,200
	CAN	20	0.52	Phenthoate	25	300	1,000		
Mtwara	S/A	21	7	Permethrin	5	1,000	1,000	Gesapaxi -combi Glyphosate	20,000 1,200
	TSP	46	15	Fenvalerate	4	1,000	500	Gramoxone Gesapax H. 500	500 2,000
Lindi	CAN	20	1	Fenitrothion	50	300	500	Actril D.5	500
	S/A	21	112	Agrason (D)		300	500	Round-up	2,000
	TSP	46	75						
TOTAL	CAN	20	85						
			1,118.52			14,210	40,550		66,021

(Source: Ministry of Agriculture)

## FISHERIES

The shoreline has many good fishing grounds. The coastal people have been fishing within these grounds for centuries and over the past few years the Government has invested in many fishing ventures for the purpose of increasing fish production as a source of protein and foreign exchange. The inter-tidal flats also support a fishery. Small seine nets are used to capture shrimps and fish, and women collect cockles, crabs and flatfish on the shore particularly at low tide.

The catch rates (tonnes/vessel/year) of marine fish  
in Mainland Tanzania 1970 - 1977

Y e a r	Z	O	N	E	S
	Tanga	Coast	Mtwara		
1970	3.94	6.15	-		
1971	5.52	7.49	7.7		
1972	6.58	9.38	10.67		
1973	5.36	9.93	7.93		
1974	6.54	10.21	8.51		
1975	6.36	9.75	14.3		
1976	7.31	19.37	10.9		
1977	7.93	12.23	11.7		

(From Annual Reports - Fisheries Division, Dar es Salaam)

Currently, Tanzania mainland has about 12,000 fishermen in the coastal region bordering the Indian Ocean who use about 5,000 fishing craft ranging from outriggers to medium-powered boats. The total marine fish production in the country is about 30,000 tonnes. The most used methods are handline traps and gill-nets and the greater concentration of fish is to be found in the immediate shallow waters - within the 12-mile coral reef belt.

Most of the fishing is artisanal, using traditional gear and small wooden boats (with some introduction of motors). Attempts have been made to industrialize this activity with only limited success. Despite this, there is still a good potential for increased production by going further offshore in areas which traditional boats cannot reach.

The use of explosives, e.g. dynamite, is still resorted to on a fairly large scale which besides killing fish destroys corals, molluscs, etc. This may seriously deplete the productivity of certain areas and after intensive use of explosives it may take years for the environment to recover. Marine communities are prone to degradation when marine conditions are changed and cause stress beyond their tolerance range.

As mentioned above, there have been several attempts by the Government and The Tanzania Fishing Corporation (TAFICO), established in 1974, to introduce industrial and large-scale fishing but without much success to date. The first venture was in 1969 when the corporation undertook jointly with a Japanese firm and Mwananchi Ocean Products Ltd. to exploit prawn grounds off the Rufiji delta, Kisiju and Bagamoyo. The venture was, however, discontinued in 1974 because of bad management. In 1979 another venture by TAFICO and MARCOTRADE, a Swiss company, was launched. This aimed

at buying prawns from the fishermen in the Rufiji delta by setting up a factory shop in the delta. Nevertheless, the project was not found to be viable. Recently TAFICO was in partnership with Atlantic Fishing Company, a Greek firm, to undertake demersal trawling in the offshore waters, a venture which was terminated in 1981. Commercial trawling has, therefore, not expanded because of the limitation of trawling grounds and unsuccessful ventures. Now, fishing is restricted to estuarine and sub-estuarine regions: Bagamoyo, Rufiji, Saadani, Pangani and Ruvu for instance. We find that 80 per cent of the prawns exported by TAFICO are collected from local fishermen.

Production of the Tanzania Fisheries Corporation (TAFICO) 1976-1978

	1976	1977	1978
Fish	141.3	203.2	342.5
Prawns	24.4	14.8	11.5

(From TAFICO Reports - Catches March to December)

Generally, Tanzania regulates its fishery in the 50 nautical miles of territorial waters through a licensing system. In practice, the enforcement of legislation is rather weak because of lack of enough patrol equipment and running expenses. Even with the establishment of the Exclusive Economic Zone (EEZ) licensing will be retained as a preferred method of regulating the fisheries in the zone. Nevertheless, local fishing companies will continue to be encouraged to expand fishing activities by acquiring better vessels that can operate between 12-200 nautical miles offshore. In Zanzibar, commercial fishing is carried out by the Zanzibar Fishing Corporation (ZAFICO). It is mainly concerned with purse seine fishing, although gill netting and trap fishing are also used. In 1979, the ZAFICO catch was 123 tonnes.

It is suspected that the Rufiji, Pangani and Ruvuma estuaries could be of great value in terms of prawns and fish production but little information is available. Production of prawns, *Penaeus indicus*, *P. monodon*, and *P. semisulcatus* for Bagamoyo and the Rufiji delta is estimated at 2,000t. Recent estimates for the Rufiji delta alone has shown that production could probably be 4,263-6,750t annually. The present production is 715t, an amount that is thought to be less than 50 per cent of the potential yield, which could be raised to 2,000t with a minimum effort (ALWM, 1981). The establishment of the Tanzania Fisheries Research Institute in 1981 was geared towards such scientific research on fisheries.

It was possible to obtain information on breakdown of catches per predominant species, but it was not easy to make a distinction between catches from lagoons, estuaries, coastal waters and high seas. Figures for the total number of fishermen (full time and part time) engaged in marine and freshwater fisheries in Tanzania for the years 1976-1980 are as follows:

1976	62,108
1977	45,999
1978	48,142
1979	61,142
1980	55,763

In accordance with the figures regarding the number of fishermen in the region, it is apparent that the population depending exclusively, and/or partially, on this activity is very small. Only 2 per cent of the entire coastal population undertakes fishing as a source of their income.

Fish production 1976-1980 by freshwater species  
(thousand metric tonnes)

Species	1976	1977	1978	1979	1980
Tilapia spp.	34,666	15,994	3,239	12,334	31,168.9
Haplochromis spp.	25,625	58,347	185,998	44,865	58,510
Bagrus	8,252	7,702	6,637	8,826	7,499.5
Clarias	13,486	11,390	6,541	7,129	7,499.5
Lunnothrisa	76,321	91,328	80,878	31,574	28,921.3
Nile perch	4,174	3,815	2,031	7,935	230
<b>Total production</b>	<b>162,524</b>	<b>188,576</b>	<b>285,324</b>	<b>112,663</b>	<b>133 829.2</b>

Fish production 1976-1980 by seawater species

Species	1976	1977	1978	1979	1980
Psettodis	75	120	55	79	10.8
Tachysurus/Cat fish	166	485	1,461	1,038	1,572
Epinephelus	566	561	685	693	757
Lethrinus spp.	7,197	8,277	7,746	4,749	6,031
Calydontidae/Parrot-fish	3,056	2,358	1,908	1,061	2,727.5
Acanthurus/Surgeon-fish	622	737	800	299	520.8
Siganus/Rabbit-fish	2,390	1,785	1,217	345	425.8
Hemiramphus/Half-beak	996	1,037	969	903	1,303.7
Sphyaena/Barracuda	1,037	-	266	275	204.5
Rhinocenthus/Trigger-fish	10,345	2,644	1,216	901	184
Carangoides/Jack-fish	-	-	-	-	1,563.9
Sardinella/Sardines	3,471	3,510	5,301	2,188	-
Chirocentrus/Wolf-herring	108	24	21	-	831.4
Thunnus/Tuna	9,993	2,339	662	372	278.6
/Blue marlin	136	286	241	107	193.1
Caranx /Mackerel	1,293	814	2,090	470	734.8
/Shark	2,114	1,525	2,964	2,833	1,752.0
/Ray	1,459	1,330	1,639	1,596	1,097
Octopus spp/Octopus	101	62	134	298	80.4
Scomberomorus spp/King-fish	1,695	1,955	1,683	897	1,979
<b>Total production</b>	<b>46,820</b>	<b>29,849</b>	<b>31,058</b>	<b>19,104</b>	<b>22,247.3</b>

### Marketing and distribution

About 80-90 per cent of the total marine production comes from artisanal fishing. The catch is landed at permanent landing sites scattered along the coast in six maritime regions - Dar es Salaam, Coast, Mtwara, Lindi, Tanga and Zanzibar. These regions have been grouped for convenience into three zones, namely Tanga, Coast (includes Dar es Salaam) and Mtwara, which includes Lindi and Mtwara Regions.

There are many problems involved in the marketing of fish in Tanzania. These problems start with the handling sites. The majority of the marine fish is sold fresh. Even fish sold to far-off places (5-15 km) is usually transported without being processed in any way. Fish destined for sale 50 km and beyond from the coast is usually dried in the sun and/or smoked on open fires instead of being preserved in cold stores and/or deep freezers. It is only TAFICO and the National Cold Chain Corporation that have cold storage facilities.

As mentioned above, fish settlements are scattered in different parts of the coast and catch is handled at numerous locations on the beach called landing stations. Although thousands of fish are caught, only a limited amount goes through proper marketing channels due to lack of a proper marketing system. There are few markets to be found but where they do exist appointees of the city/municipal councils conduct the auction and ultimately collect any kind of levy that might be imposed. In other places where there are no proper markets, the transactions take place between the fishermen and the fishmongers, or between fishermen and consumers directly. The fishmongers take their fish where there is a demand for it. Sometimes they take it to a consumers' market, in which case they have to pay a levy to the market authorities. At any rate, most of the fish caught is sold locally. Factors which limit long-distance distribution are lack of good transport, storage and processing facilities. The state of the roads situation and the relatively short distances for distribution of the bulk of fish landings make bicycles the most practical and also the most commonly used means of fish transport in the region. Since the catch is invariably small and supply is constantly much lower than demand, most of it is still fresh when bought locally.

However, the system of auctions by the fishermen themselves combined with the large number of small-scale fishmongers has created keen competition, forcing fish prices up. In most coastal areas fish is a traditional staple food additive which is not easily replaced by other sources of protein.

There are some public and private companies engaged in fishing but their participation in marketing is restricted. The National Cold Chain Organization (NCCO) is the only organization which is at present involved in intra-regional marketing on a small scale. For instance, in 1977 NCCO marketed 800t of fish and fish products which is only 0.3 per cent of the total fish production of the entire country (fish production the same year was 260,611t). There is still a chance for the organization to expand fish marketing activity on a large scale at the national level.

### Retail of fisheries products

Both fresh and processed fish is mostly sold through public markets to consumers. Few of those in urban areas are permanent and many of them function only on certain days of the week. Facilities available for fish trade in these markets are inadequate and poor in quality. In many markets there is not enough space and the traders sell outside the markets where fish is placed in the hot sun and sometimes even in the rain.

### Importance of fisheries products

In Tanzania the main religions are Islam and Christianity. These religions, as well as other local beliefs have no prejudice against the eating of fish which is consequently a popular food among all Tanzanians. Past records show that people in the northern central plains were mostly nomads and traditionally meat-eaters, but now this tribe like almost all others in the country, have started to consume fish. In the past people tended to prefer a particular type of fish (freshwater or marine). But recent surveys conducted in Dar es Salaam show that habits are slowly changing. The people from up-country, who are more familiar with freshwater fish, said that they were even consuming sea-fish. They have given several reasons for this change, the important one being economic. In Dar es Salaam the availability of freshwater fish is limited and the price of it is higher than that of sea-fish. Several consumers also said they were only used to certain species of fish, for example Tilapia. After they settled in Dar es Salaam they started to eat Changu fish as a substitute for Tilapia, Changu bearing some resemblance to Tilapia.

This all shows that traditional preferences are changing. Now most people have started to eat all species and types of fish provided they can afford them. All these are indicators of a further increase in fish consumption in the country. Nevertheless, no proper survey has yet been conducted to determine the trends in consumption as between fish and other flesh; but since the daily catch is always very low, the consumption of other meats is bound to remain high.

In Tanzania, fish consumption is high in production areas as well as in big cities where adequate fish sales facilities exist. Consumption is much lower in inland areas which is mainly due to long distances between production and consumption areas. Lack of proper preservation and processing facilities and the cost of distribution also contribute a great deal to the low consumption. The table below gives the average fish consumption for the past few years in the country. Figures for the coastal area alone were not available.

Fish consumption in Tanzania

	1975	1976	1977	1978	1979
Population	14,938,000	15,037,800	16,100,000	17,048,800	17,576,800
Fish supply (t)	193,353	239,273	260,396	211,377	179,485
Average consumption (kg)	12.4	14.9	15.7	12.4	10.2

N.B: Total supply (production, imports, exports) is divided by population.  
(Source: Fisheries Statistical Reports)

### Export

Export of Tanzanian marine products include dried fish, bêche-de-mer, seaweeds, crustaceans, shark-fins, seaweeds, sea shells, etc. Destinations are to Europe, the Middle-East, South-East Asia and neighbouring African countries.

Export of marine products over the last years - 1973-1980 (in tonnes)

Product	1973	1974	1975	1976	1977	1978	1979	1980
Fresh fish	4.6	18.9	42.4	-	7.2	10.1	-	-
Dried fish	948.9	163.4	138.3	-	82.6	59.6	-	-
Crustacea	53.0	62.7	66.5	72.9	96.8	83.9	96.9	48.9
Bêches-de-mer	35.5	24.1	14.2	5.8	36.1	-	39.4	71.9
Seaweeds	112.7	204.4	49.8	-	-	-	-	-
Sea shells	389.9	266.7	557.5	5.8	169.3	-	198.9	297.3
Shark-fins	-	-	-	-	-	-	2.1	0.9
<b>T O T A L</b>	<b>1,544.5</b>	<b>740.2</b>	<b>868.7</b>	<b>84.5</b>	<b>392.0</b>	<b>153.6</b>	<b>337.3</b>	<b>418.4</b>

(Source: Fisheries Statistical Reports)

Fish farming

In Tanzania very little attention is given to fish farming or aquaculture as an efficient way of producing much needed protein. But as the human population of coastal States starves for protein, such activities will become increasingly important in supplementing current production. Tanzania with its long coastline has many important rivers which create ideal conditions for the development of estuarine aquaculture, both for finfish and shell fish culture. However the prospective Tanzania fish farmer needs to be educated because, as Odum (1971) states: "Mariculture like agriculture has its hidden costs and is not a 'free' gift of nature".

The coastal regions have so far directed their resources towards the development of coastal fisheries and very little has been done about aquaculture. It is in Mtwara Region only where an attempt is being made to develop fish ponds in Masasi District, and this is vital because there is an interplay of factors which hinder livestock development there. In this district there are about 32 small fish ponds.

To date, the handling of fish and fish products has been far from satisfactory. There is a need to improve sanitary fish handling techniques by providing a suitable infrastructure in terms of hygienic conditions for fishermen. This could be in the form of smoking Kilvas, drying racks and refrigeration facilities, etc. Due to the hot climate and complete lack of cooling on board the fishing vessels, there is an urgent need for preservation upon landing, either by cooling or as is usually the case, by other technically simpler means, or else quick distribution of the fresh fish to the consumer is vital.

Tanga Region: Number of fishermen and number of vessels per station (1970-1973)

Station	Number of fishermen				Number of vessels			
	1970	1971	1972	1973	1970	1971	1972	1973
Moa	340	427	792	478	109	119	345	164
Tongoni	225	429	475	345	113	137	146	128
Kwale	480	562	611	549	114	177	205	196
Kigombe	225	349	229	178	109	106	71	50
Pangani	147	433	162	251	76	184	99	101
Tanga	457	399	373	412	113	162	119	148

Catch of fish: by species in the marine waters of Tanga region

S P E C I E S	1 9 7 8		1 9 7 9		1 9 8 0		1 9 8 1		1 9 8 2	
	Weight	Value	Weight	Value	Weight	Value	Weight	Value	Weight	Value
Lethrinus	635.4	3,773.5	634.8	4,195.3	640.4	4,133.7	551.1	6,874.1	861.0	16,123.9
Sharks	402.7	1,289.5	688.5	2,613.8	780.8	2,587.2	185.2	1,698.8	169.2	2,690.0
Rays	429.4	1,354.1	472.4	1,980.5	478.3	1,844.8	692.5	4,511.7	607.6	7,423.9
Scomberomorus	496.6	2,648.2	390.1	3,243.8	403.5	3,184.3	552.9	6,803.9	167.4	419.7
Thunnus	429.0	2,223.6	261.7	1,966.5	285.9	1,764.8	306.3	3,793.5	326.4	4,548.9
Carangoides	213.4	1,009.6	371.1	2,575.6	402.4	2,570.9	528.8	7,809.6	665.1	11,089.7
Xiphiasgladius	112.8	502.5	49.0	538.3	70.6	259.4	37.1	649.3	102.5	1,827.1
Cephalophalos	70.1	298.3	82.2	4,751.2	97.9	469.6	141.3	1,469.5	140.8	2,035.2
Rachycentron	59.8	274.6	51.4	376.1	60.1	367.6	44.3	601.4	60.7	1,015.6
Siganus	251.1	1,385.0	153.9	948.3	171.5	934.1	459.6	4,311.5	533.4	8,642.2
Nemipterus	41.2	188.4	7.8	25.0	18.5	25.6	11.8	66.0	4.4	86.0
Tachysurus	65.0	210.3	132.7	577.7	152.9	569.1	37.5	385.3	34.6	546.0
Sphyraena	55.3	320.7	112.0	780.2	115.6	770.6	132.1	1,689.6	89.6	1,669.1
Chirocentrus	23.5	77.7	21.3	189.1	23.9	185.9	17.8	94.8	12.0	136.0
Rastreligar	220.6	1,323.2	179.3	1,240.1	314.1	1,331.2	649.6	5,364.6	392.7	5,703.6
Liza	178.7	1,017.2	111.8	919.0	108.9	919.3	271.3	3,083.7	95.1	2,278.3
Parrot-fish	333.9	1,388.4	196.1	876.2	185.5	841.0	132.7	724.3	352.2	4,755.0
Prawns/Lobsters	44.6	270.4	29.2	2,165.0	40.0	2,061.6	302.2	4,467.5	112.5	2,270.4
Sardines/Herring	819.4	1,484.7	653.1	1,841.8	748.0	1,813.5	546.1	1,761.7	230.0	1,593.4
Others	2,116.0	7,791.0	2,037.3	11,198.3	2,009.8	10,950.5	720.6	7,117.9	1,987.6	31,537.8
T O T A L	6,996.5	28,830.9	6,635.7	49,558.0	7,058.6	37,604.7	6,320.8	63,278.9	6,944.8	111,988.9



## MINERALS (INCLUDING OIL AND SAND) EXPLORATION AND EXPLOITATION

### Quarrying

Most of the building construction industry and related engineering works depend on the coralline limestone of, for instance the Wazo - Kunduchi platform in Dar es Salaam/Coast Region. A number of quarries have developed along this zone, some of them supplying coralline limestone material for the Wazo Hill Cement factory and sandstone for housing construction. Prospecting for stone and sand is done by individual quarry operators. There is great pressure on the exploitation of these quarries to meet the demands of the building industry. Some of the material from the quarries increases the amount of river load during the rainy season and hence contributes to the quantity of detritus deposited in the sea.

The total quarry area for Coast/Dar es Salaam Regions is about 300 hectares of which Kunduchi accounts for 236 ha, Mjimwema 35.3 ha, and Bagamoyo 17.9 ha. Figures for Lindi and Mtwara Regions were not available. For Tanga the number of mining and quarrying areas is 85 of which 16 are in the Amboni, Pongwe and Maweni areas in Tanga Town and the remainder in the rest of the Region. There are also some deposits of Jurassic limestone in the coastal area which have not been exploited.

### Coastal salt works

In the 1950s, salt works in Kunduchi were confined to the depression encompassing the Kunduchi - Manyema creek in the mangrove swamps. To date, many salt-pans have been opened up necessitating the clearing of existing vegetation including mangroves. Extensive salt works are carried out in the depression between the beach ridges of Kunduchi, the raised Wazo-Kunduchi reef limestone outcrops, Bagamoyo, Mjimwema and Mbwawamaji, near Tanga town and the Mtwara coast.

Along salt-work sites, sea-water flows into the prepared salt-pan at very high tide in the dry season and is trapped inside. In the following few days water is pumped through a series of pans from which it is evaporated by the sun. When the salt is crystallized it is scooped up. Many salt-works are sited in environments where natural sand-dunes can protect the site from flooding by tides or storms. Care is taken to ensure that the underlying ground is impervious to avoid the necessity of lining the pans with concrete. Clearing for such civil works allows sediments washed from the sites into the rivers or streams by heavy rainfall to be transported to the sea. Consequently, the amount of sediment load deposited along the beach increases and is acted upon by waves, currents and tidal fluctuations. Subsequently, modifications occur along the beach with features such as sand bars or beach ridges developing.

Salt-works occupy a total area of about 709 hectares for the three coastal belt regions, namely Coast, Dar es Salaam and Mtwara. In Dar es Salaam region there is the Kunduchi area with 242 hectares and Mbwawamaji with 35.3 ha. In Coast region, these salt-pans are found in Bagamoyo covering an area of 145 ha, while at Mtwara coast the area covered is about 129 hectares.

### Oil and natural gas exploration

Gas exploration along the Tanzania Coast has been in progress since 1969 when the Tanzania Petroleum Development Corporation was established to promote the growth of the oil industry. However, the mineral now associated with seabed exploration in Tanzania is the natural gas which is trapped in sedimentary rocks of the lower Jurassic period off the coastal belt at Songosongo. Exploration goes as deep as

15,000 ft. The nature of the reservoir rocks that yield gas at Songosongo is not yet known but adequate reservoir rocks are considered to be present. The capacity of the Songosongo reservoir is recorded to be  $40 \times 10^9 \text{ m}^3$ .

Tanzania and its islands have had 22 wells drilled; so the generation and migration of oil and gas is regarded as poor, at most moderate. In fact oil has been considered not to be worth commercial endeavour. The drilling goes deep especially in the part of the basin that is in the Indian Ocean. Thus, while the sedimentary volume parameter is excellent, the record of hydrocarbon recovery is poor and disappointing.

Although exploration has been done by 22 wells only a few have indicated the presence of gas. The exploration has been going on both inshore and offshore but only offshore drilling has proved feasible. The offshore exploration has been carried out at the following areas: Ras Muchuisi - north of Bagamoyo, Songosongo, Kimbiji - 35 km south of Dar es Salaam, Mnazi Bay (Msimbati) at Mtwara, Mafia, Zanzibar and Pemba. So far, it is only Songosongo, and Msimbati which have proved to contain enough gas for exploitation. The capacity of gas at Songosongo is shown above but for Msimbati the extent and level have not yet been clearly established.

The natural gas at Songosongo has influenced the Government to plan for the gas/fertilizer complex at Kilwa in Lindi Region. The complex to be known as the Kilwa Ammonia Company Ltd., would utilize the gas at Songosongo to manufacture ammonia and urea. The plant would be export-oriented and expected to produce 444,150t of anhydrous ammonia a year and 534,750t of granular urea. It should be stressed that exploitation has not yet started and the impact of the venture on the marine ecosystem cannot therefore be adequately discussed.

#### TOURISM

The Tanzania Tourist Corporation (TTC) came into existence in April, 1969 to promote and develop the tourist industry in the country. The corporation has opened offices abroad particularly in the United States, the Federal Republic of Germany and Sweden in an endeavour to publicize the tourist potential available in the country. Nationally, the corporation has acquired a number of hotels to cater for the industry. Today the corporation owns and manages 15 hotels comprising 1,606 rooms of first-class standard. Twelve are owned wholly by the Corporation while in the other three hotels it holds the majority of the shares. TTC also has minority shares in Bahari Beach Hotel, Furaha ya Visiwani (Zanzibar) and the recently opened Embassy Hotel. On the whole TTC is responsible for 40 per cent of the total number of hotel rooms available in the country. A few of the international hotels are privately owned.

Tourism is very significant in the northern zone particularly in Moshi and Arusha because of the snow-capped mountain Kilimanjaro and the wildlife areas (Ngorongoro and Serengeti). In these areas efforts are being made to improve and develop a suitable infrastructure. In the coastal belt, tourism is basically important in Dar es Salaam. Hotel occupancy here is only partially dependent on tourism since the business community also places a heavy demand on hotel space and in addition, a number of hotel rooms are occupied on a semi-permanent basis by individuals and families awaiting permanent housing.

There are a large number of hotels in Dar es Salaam, eleven of which are classified as tourist class. In Zanzibar, Mafia Islands and Tanga, there are a few

hotels of the same category. Currently TTC is expanding the New Africa Hotel with 133 additional rooms. According to the TTC ten-year development plan for tourism, as from 1980 the Corporation intended to build Dar es Salaam International Hotel (500 rooms), Mjimwema Beach Hotel (300 rooms) and Zanzibar Beach Hotel (100 rooms), as well as others outside the coastal belt. But because of lack of foreign support in terms of finance, the proposals have not yet been implemented.

Tourist Class Hotels in the Coastal Belt

Hotel	Rooms	Beds	Rooms under expansion
Kilimanjaro Hotel	198	396	
New Africa Hotel	104	144	133
Kunduchi Beach Hotel	100	200	
Bahari Beach Hotel	100	200	
Motel Agip	57	102	
Twiga Hotel	31	57	
Africana Hotel	162	300	
Oyster Bay Hotel	23	44	
Mkonge Hotel (Tanga)	50	100	
Mafia Island Lodge	30	60	
Zanzibar Furaha ya Visiwani	35	61	
Embassy Hotel	150	300	
Rungwe Oceanic Hotel	28	48	
Silver Sands Hotel	43	86	
<b>T O T A L</b>	<b>1,111</b>	<b>2,098</b>	<b>133</b>

For a number of years, reliable data on tourism in relation to tourist arrivals, spending, foreign exchange earnings, occupancies, etc. were not available. Nevertheless, the recorded number of tourists who arrived in the country as from 1976 was as follows:

1976	163,000
1977	118,400
1978	148,400
1979	156,000
1980	84,000
1981	128,000

(Source: Annual Economic Survey, 1982)

It was also not easy to obtain figures for tourists who visited the coastal belt. But it could be assumed that most of those who arrived in the country, particularly the northern zone, visited Dar es Salaam to see the beach and the game reserves such as Mikumi in Morogoro Region. With the closure of the border between Tanzania and Kenya and the world-wide economic recession there was a drop in the number of tourists arriving in the country. Now there are indications that tourism is recovering from the slump experienced immediately after the border closure in 1977.

The Tanzania tourist industry earned the nation T. Shs. 738 million in foreign exchange during the period 1978-1982. The breakdown of yearly revenue is as follows:

Year	T. Shs.
1978	96,500,000
1979	142,450,000
1980	164,500,000
1981	184,000,000
1982	150,550,000
Total	738,000,000

(Source: Bank of Tanzania)

The estimated number of workers in hotels and tourism-oriented offices in the coastal belt is 3,500. At present Tanga, Mtwara and Lindi Regions do not have much to offer in terms of tourism and thus the infrastructure is not geared towards this activity. The services offered are too limited to attract many tourists.

REFERENCES

- Anonymous (1981) Study of the Impact of the Stiegler's Gorge; Multipurpose Project on Fisheries in the Rufiji Delta and Mafia channel. Atkins Landwater Management for Rufiji Basin Development Authority.
- Bratap, H.B. (1982) A Review of the Demersal Fisheries of Tanzania. Kunduchi Marine Biological Station, University of Dar es Salaam.
- British Technical Staff (1981) Mtwara Integrated Development Plan 1981 - 1986.
- British Technical Staff (1981) Lindi Integrated Development Plan 1981 - 1986.
- Bryceson, I. (1978) Tanzania Coral Reefs at Risk. *New Scientist*. 80(1124):115
- Bryceson, I. (1978) An Ecological Study of the Phytoplankton of the Coastal Waters of Dar es Salaam. Ph.D thesis, University of Dar es Salaam.
- Bryceson, I. (1982) Coral Reefs: An Overview and a Description of Mbudya Island. Institute of Marine Science, Zanzibar.
- Bryceson, I. (1981) A Review of Some Problems of Tropical Marine Conservation with Particular Reference to the Tanzania Coast. Marine Biological Station, University of Dar es Salaam.
- Bryceson, I. (1979) An Assessment of the Ecological Impact on the Marine Environment of Present and Proposed Sewerage System for Dar es Salaam. Unpublished Report. Howard Humphreys and Partners, Dar es Salaam.
- Buckley, T.A. (1928) Mangrove Bark as a Tanning Material. *Malay - Forest Record* 7. Particular Reference to Fisheries. University of Dar es Salaam.
- Bureau of Statistics (1982) Quarterly Statistics Report on Hotels and National Parks. Third Quarter.
- Bwathondi, P.O.J. & Ngoile, M.A.K. (1982) Management of Marine Resources with CIDA (1975) Integrated Development Plan, Dar es Salaam Region.
- Fin Experts (1975) Report on the Tanga Master Plan 1975-1995. Ministry of Lands, Housing and Urban Development.
- Finnwater (1973) Mtwara-Lindi Water Resources Inventory, Phase I. Helsinki Finland.
- Hamilton, H.G.H. (1975) A Description of the Coral Fauna on the East African Coast. M.Sc. Thesis, University of Dar es Salaam.
- Heald, E.J. & Odum W.E. (1975) Mangrove Forests and Aquatic Productivity. In Hasler A.D. (ed) *Coupling of Land and Water System*. Springer Verlag, Berlin.
- Humphreys, I. & Partners (1980) Dar es Salaam Sewerage and Sanitation Study Vol.I-V Master Plan, Ministry of Lands, Housing and Urban Development.
- Inter-Consult (1981) Tanga Master Plan Interim Physical Plan - Report No.I. Ministry of Lands, Housing and Urban Development.

- Kamukala, G.L. (1982) Land-use Planning as a Basis for Abating Land-based Sources of Pollution. Housing and Urban Development.
- Kileo, G.J. (1972) Forestry in Tanzania pp. 215-220. In Morgan W.T.W. (ed) East Africa, Its People and Resources. Oxford University Press.
- Kjekshus, H. (1977) Ecological Aspects Related to the Stiegler's Gorge Project. NUPI Forum 10: 1 - 35.
- Kyanka, P.S. (1982) The Importance of Investing in Fishery Resources and Scientific Research along the Coast of Tanzania. Fisheries Research Institute.
- Mainoya, J.R. (1979) Effects of Environmental Pollutants on Aspects of Physiology in Marine Fish and Other Wildlife. University of Dar es Salaam.
- Mainoya, J.R. & Mwisege, B. (1982) A critical Appraisal on the Development of Marine Sciences in Tanzania. University of Dar es Salaam.
- Majani B.B.K. & Kamulali, T.W.P. (1979) The Planning of Human Settlements. Ardhi Institute Symposium.
- Masaki, R. (1981) Grazing Methods: their Impacts on the Environment. Ministry of Livestock Development.
- McCusker, A. (1971) The Mangrove Vegetation of Dar es Salaam. University of Dar es Salaam.
- McCusker, A. (1975) The Kunduchi Mangrove Basin. University Science Journal, Dar es Salaam I(1) 30 - 40.
- MacNae W., (1974) Mangrove Forests and Fisheries. FAO/UNDP, Rome.
- Meghji, P.N. (1981) Ocean Transport and Pollution of the Environment. Ministry of Communication and Transport.
- Ministry of Lands, Housing & Urban Development (1970) A Plan for Mtwara 1970 - 1980.
- Mosha, A.C. (1979) The Process of Urbanization in Tanzania. Ardhi Institute, Dar es Salaam.
- Mtiro, I.J. & Berege, E.H. (1978) Regional Physical Planning in Tanzania as a Basis for Economic Planning (unpublished). Regional Planning Officers Conference, Tanga.
- Mtiro, I.J. (1980) Human Settlements Policy in Tanzania. Ministry of Lands, Housing and Urban Development.
- Mushala, H.M. (1982) Beach Processes and Coastal Land Form Evolution around Dar es Salaam. Department of Geography, University of Dar es Salaam.
- Mwisege, B. (1973) Some Aspects of the Ecology of Sandy-muddy Inter-tidal Zone in Dar es Salaam Area. M.Sc. Thesis, University of Dar es Salaam.

- Mwaisege, B. (1982) Expected Impact of the Planned Stiegler's Gorge Dam on the Ecology of the Rufiji Delta and the Mafia Channel. University of Dar es Salaam.
- Mwaisege, B. & Mainoya, J.R. (1981) Mangrove Habitats: Problems of Conservation in Tanzania. University of Dar es Salaam.
- Ngoile, M.A.K. (1982) A Review of the Demersal Fishery in Tanzania. University of Dar es Salaam.
- Rudman, W.B. (1974) Survey of Possible Ecological Effects of Proposed Developments to Dar es Salaam Harbour (unpublished). Bish and Partners.
- Sankarankutty, C. (1974) Coastal and Estuarine Aquaculture - Case for Introducing Prawn Culture in Tanzania. (Eds) Msangi A.S. and Griffin J.J.
- Seleki, B.A. (1980) A Brief on the Experiences With the Sites and Services and Squatter Upgrading Projects. In Tanzania Ministry of Lands, Housing and Urban Development.
- Schiller, E.J. & Bryceson I. (1978) Beach Erosion in Dar es Salaam. University Science Journal Vol. 4 Nos. 1-4.
- Shanmugan, A.T. (1982) The Control of Oil Pollution in Tanzania Coast. Tanzania Harbours Authority.
- Sichone, W.M. (1982) Tanzania Marine Policy. Ministry of Natural Resources and Tourism, Dar es Salaam.
- Tanzania-Sunday News 25/6/1983
- Urasa, F.M. & Mainoya, J.R. (1982) The Potential of Estuarine Fish Aquaculture in Tanzania. University of Dar es Salaam. Institute of Marine Sciences.
- Vanlank, H. Veld (1980) Migration and Squatting and Implications this has on Water Supply and Sanitation (unpublished). Ministry of Lands, Housing and Urban Development.

# MAJOR INDUSTRIAL AREAS IN DARES-SALAAM.

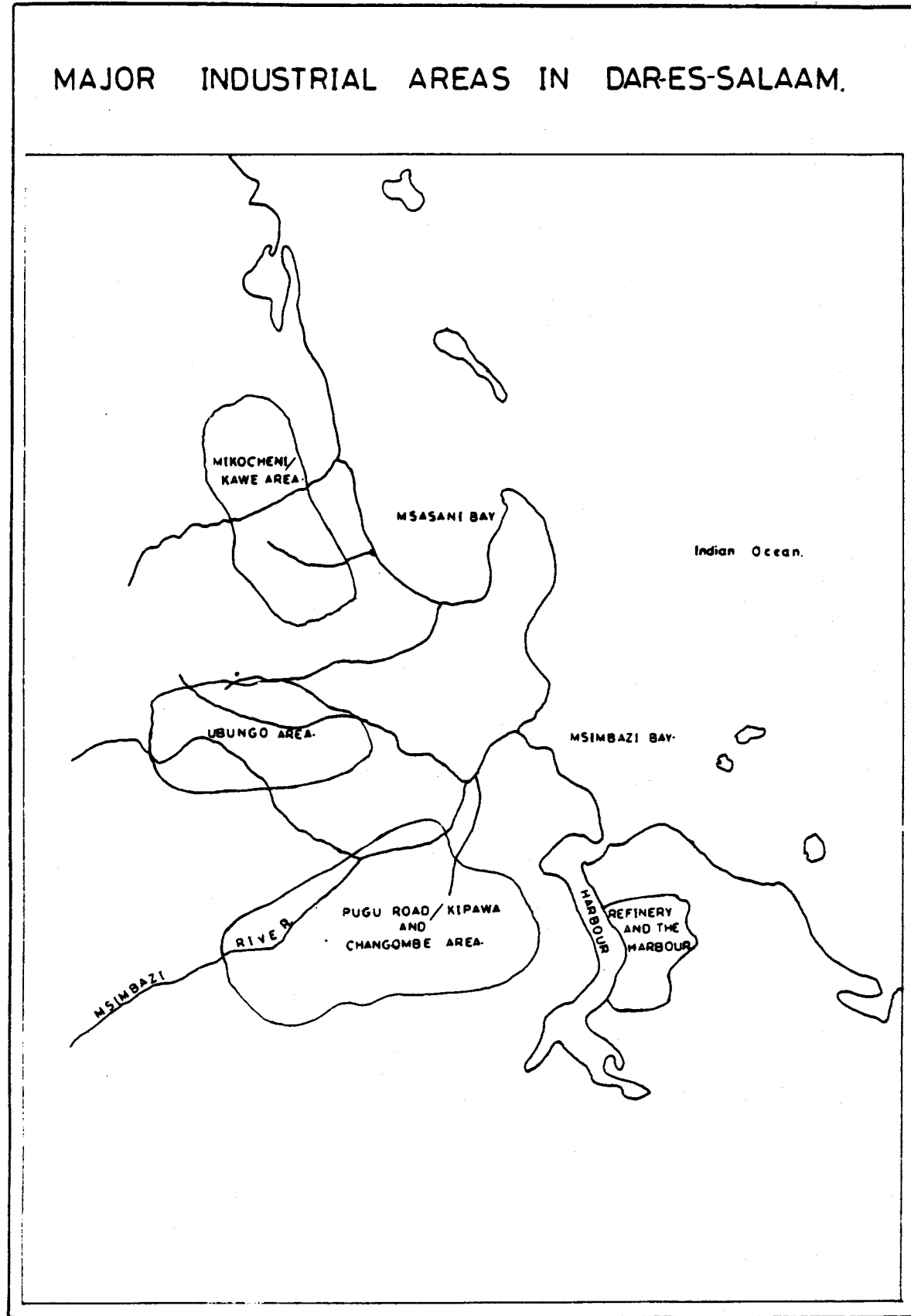

Figure 1



# COASTAL BELT OF TANZANIA.

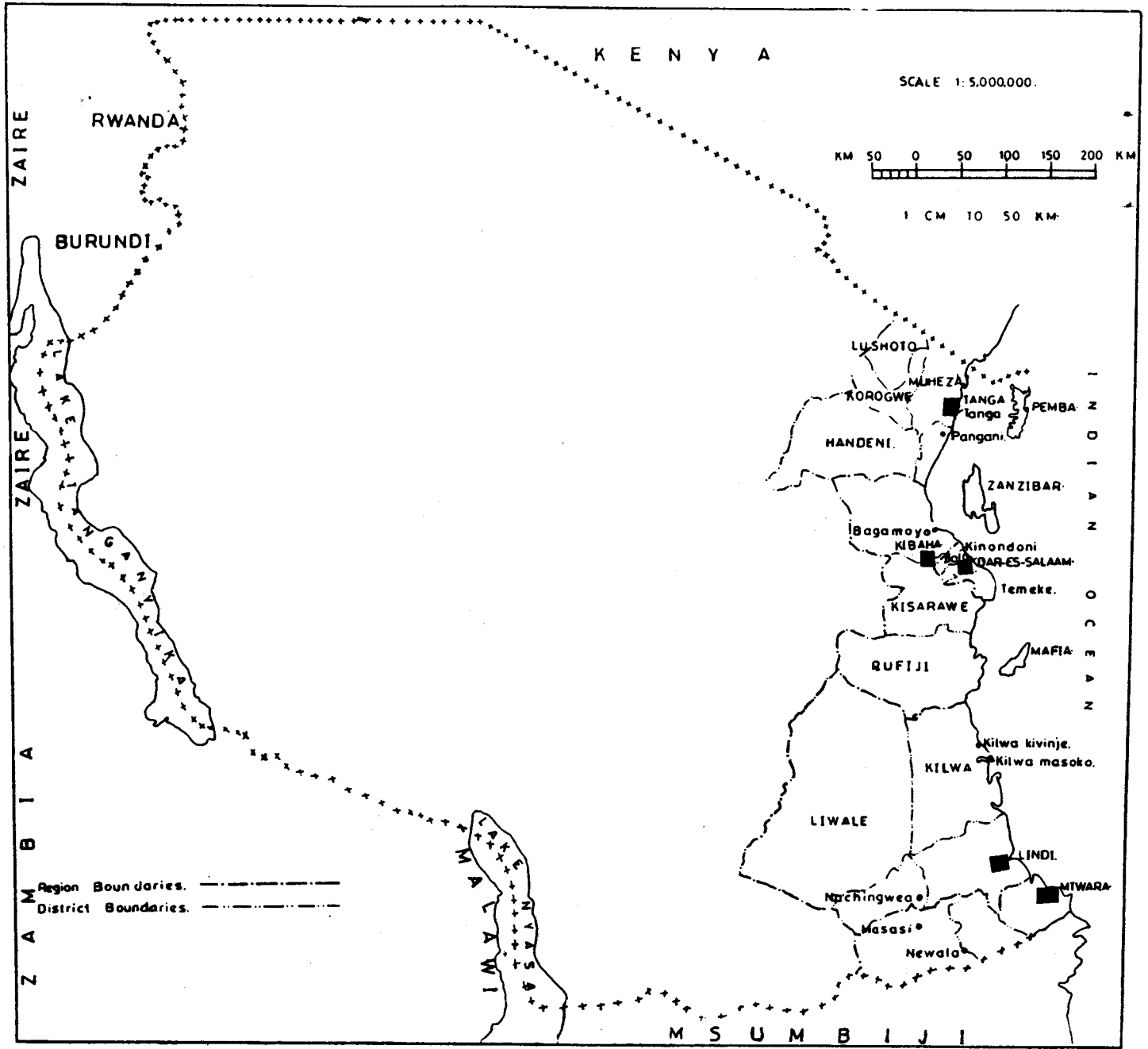

Figure 2

Crude Oil Imports 1972 - 1982

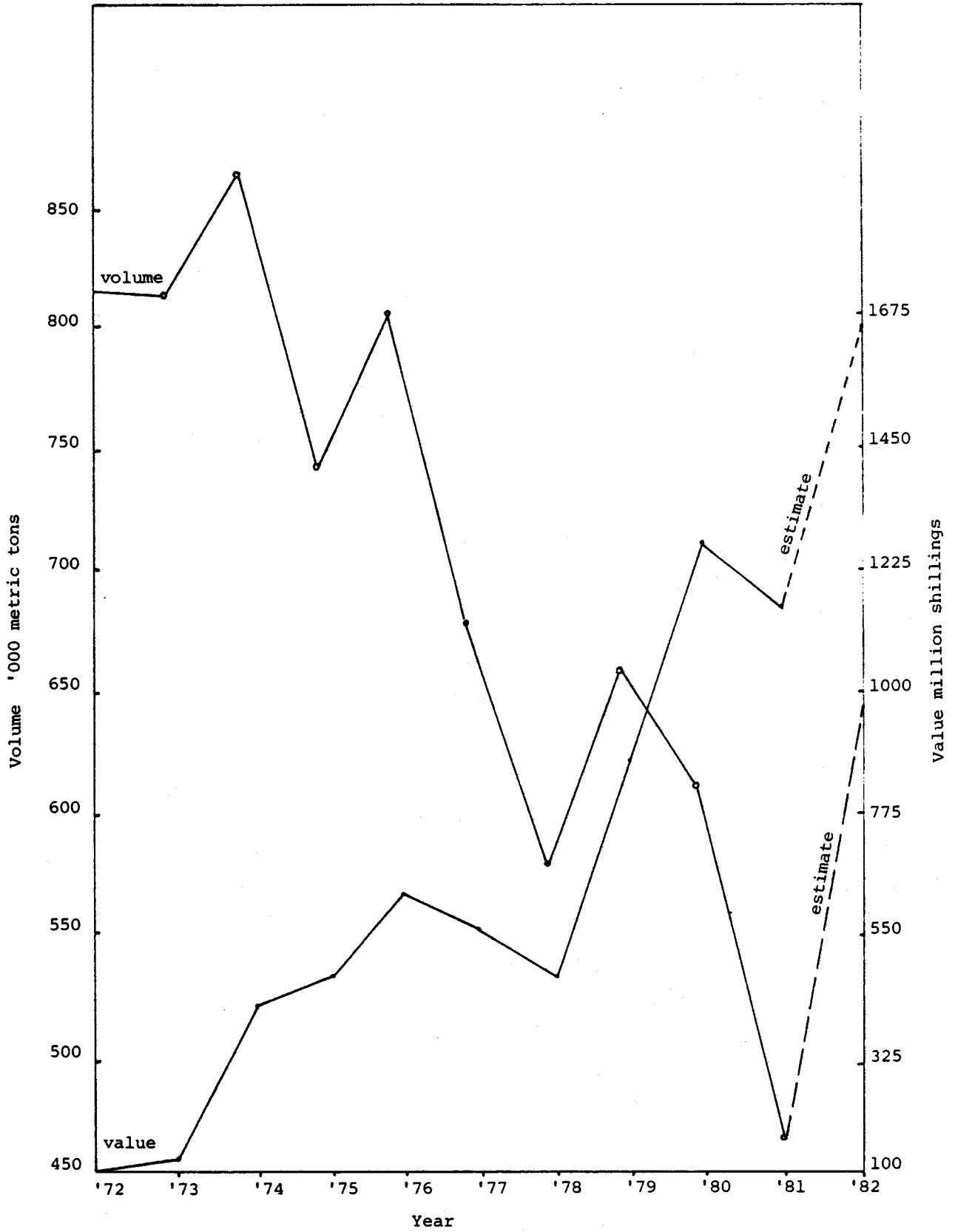
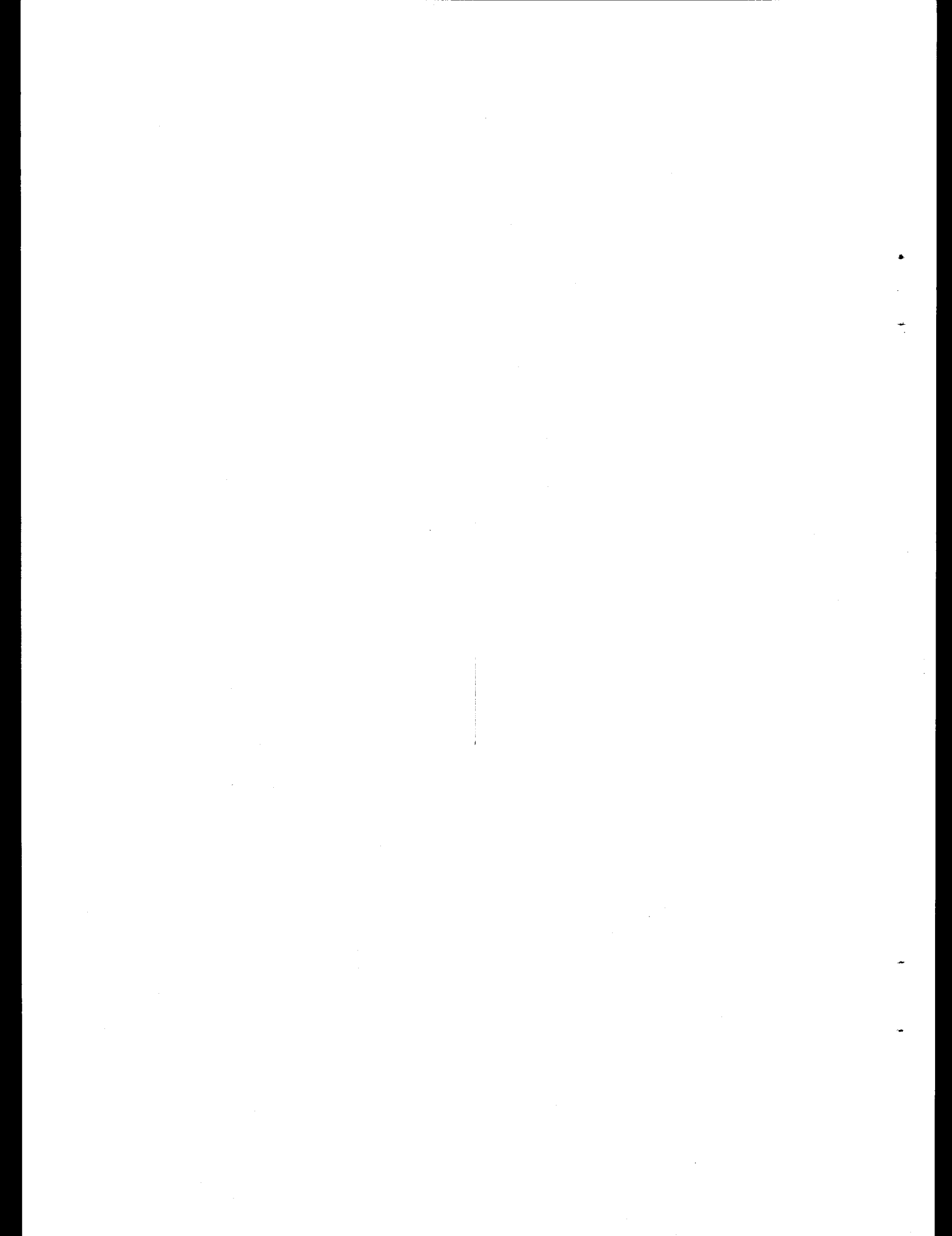

Figure 3



KENYA NATIONAL REPORT : by Mutua-Kihu

INSTITUTIONAL ARRANGEMENTS FOR ENVIRONMENT PROTECTION

Nairobi, the capital city of Kenya is the headquarters of UNEP and Habitat, two full-fledged United Nations bodies dealing with matters related to Environment management and human settlements issues. The establishment of UNEP and Habitat followed the convening of the United Nations Conference on the Human Environment (Stockholm, Sweden 1972) and the United Nations Conference on Human Settlements (Vancouver, Canada, 1976), respectively.

The location of these two bodies in Kenya has considerably influenced the structure of the institutional framework for dealing with environmental matters in Kenya. In 1974 the National Environment Secretariat was established in the Office of the President, initially as a liaison office with UNEP, and later with the technical aim of the Government co-ordinating environmental matters in the country. The liaison function was subsequently taken up by the Kenya mission to Habitat which had been established later. The National Environment Secretariat provides among other things the technical liaison basis for the two missions.

Owing to the fact that environmental matters do not respect institutional boundaries it was felt that the Secretariat's co-ordinative role would be best served by the creation of an inter-ministerial committee on Environment and an interministerial committee on Human Settlements both chaired by the Secretariat's Director. The secretariat's technical divisions provide secretariat support for these two interministerial committees. It is through these two committees, each of which has a number of standing task forces, that part of the agenda of the secretariat's work is formulated and the results are subsequently evaluated.

The remainder of the agenda is formulated by the Ministry of Environment and Natural Resources, established in 1979, and by the secretariat, which receives policy guidance from the former.

Other government ministries deal with specific matters; for example, the Ministry of Water Development deals with water pollution control (as mandated by the Water Act); the Ministry of Health (as per the Public Health Act) and the Ministry of Labour deal with matters related to the working environment (as per the Factories Act), etc. Local government by-laws also contain enabling clauses that make it possible for local authorities to intervene in cases of environmental degradation.

The secretariat itself was not created by an Act of Parliament and uses administrative mandate and goodwill on the part of the other government departments and ministries. A National Environment Enhancement and Management Bill has been proposed which provides for an environmental impact assessment and evaluation process on the basis of which legislative action can be initiated against any development, governmental or otherwise, which violates established environmental standards and norms. The act will, in particular, give legal powers to the Minister responsible for environmental matters to induce other ministries and departments to implement legislative instruments at their disposal to protect the environment.

Apart from sectoral and resource studies, as well as educational and informational activities, regional programmes have been developed to be carried out at the district level (in consonance with the new national development strategy whereby the District has been identified as the principal unit of development

planning and plan implementation), the province and the regional development authorities.

The recently launched coastal zone management project falls under this regional framework and will be the main vehicle through which Kenya's national inputs into the East African Regional Seas Programme will be directed. The Project is currently being evolved in the secretariat but will eventually involve other government agencies and institutions including the coastal, provincial and district administrations.

#### SYNOPTIC PHYSICAL GEOGRAPHY OF THE COASTAL REGION OF KENYA

The Coast Province of Kenya is made up of the administrative districts of Kwale, Mombasa, Kilifi, Lamu, Taita and Tana River. The region lies between the equator and latitude 4°50'S and between longitude 37°30'E and the Indian Ocean. The 450 km coastline is bordered by Tanzania to the south and Somalia to the north.

Most of the region, and especially the north, lies at an altitude of between 0 and 200 m above sea-level. Parts of the south rise to between 200 m and 1,000 m above sea-level with the Taita Hills rising to above 1,500 m.

The coastal region and sections of the lower north have a Quaternary sediment coral and sandstone geology, permeated by Tertiary sediment sections in the areas around Malindi and smaller sections to the north and south of Kilifi and south of Mombasa town. The latter geology is bordered inland by a narrow strip of Jurassic rock structures permeating further inland into Triassic, and still further into carboniferous-Permian geologies. Sections of the inland south are made up primarily of basement rock structures.

The principal soil types in the region include a narrow coral rag running almost the length of the coast, bordered inland by an even narrower strip of coastal sands southwards from midway between Malindi and Kilifi, this strip widening appreciably to the north, where it is permeated by narrow latitudinal bands of grumosolic brown clay soils. These bands extend inland over the entire region and cut across other soil types. The section further inland and to the south of Lamu is covered by alternate bands of brownish-yellow, mottled brown, dark red, and dark brown loams. Beyond these loams the grumosolics are permeated by thick bands of ash and pumice soils.

Ecologically, the area bordering the sea and extending to approximately 20-40 km inland is typical, potentially good agricultural land with patches of forest, grasslands and bushlands. Further inland there is a narrower strip of marginal agricultural potential bearing savannah-type vegetation. This band averaging some 20 km in breadth and fades into shrubby habitats some of which are suited for agriculture.

Thus the coastal region combines various proportions of woodland, wooded grassland and bushland with patches of forest and bushed grassland and is thus a fairly ecologically diverse environment.

Beyond the shoreline, the continental shelf extends some 160 km into the sea with coral reefs straddling most of the coast but not extending much more than 2 km seawards.

The coastal belt receives a rainfall of 750-1,250 mm annually. A wide band further inland, averaging some 60 km in width and running roughly parallel to the coast, receives some 500-800 mm of rainfall annually. Beyond this band and still further inland, the rest of the region receives below 250 mm except for a roughly concentric ring around the Taita Hills, where annual rainfall rises progressively to 1,500 mm. A very narrow band around Mombasa town and to the south receives rainfall of between 1,200-1,500 mm annually (these figures are mean measurements).

Around the coast the year begins dry in January and remains so until March when rainfall gradually increases. A fairly rapid increase occurs in April and builds up to a maximum in May. Then rainfall decreases steadily, but significant amounts are still recorded in October and November. During December a rapid decrease is experienced that leads to a rainfall minimum in January and February.

The bulk of the region has an annual mean temperature of above 22° (except for a section of Taita Taveta and northern Kwale where temperatures are between 18° and 22°C. Only in a ring around the Taita Hills do temperatures fall progressively to between 10° and 14°C at the highest altitudes. On the coastal strip temperatures rise to above 30°. Relative humidities, moving as they do inversely with temperatures, rise to 80 per cent and fall to 59 per cent mean at 1200. <sup>1/</sup>

## LAND USE AND AGRICULTURE

### Major land use patterns

The Tana River District can be divided into two major categories, namely, agricultural crop-land all along the Tana basin and range-land covering the rest of the district, with potential for irrigation in areas away from the basin, as exemplified by the Hola and Bura Irrigation Schemes. There is a total of 3,920 km<sup>2</sup> of alienated land, 16,667 km<sup>2</sup> of unalienated land, 3,457 km<sup>2</sup> of National Parks (mainly the Tana River Primate and the Kora National Reserves), 14,507 km<sup>2</sup> of trust land and only 8 km<sup>2</sup> of freehold land.

Areas of high rainfall in the Taita/Taveta District are rocky and cannot, therefore, be used for agriculture. The district has some 1,930 km<sup>2</sup> of Trust Land (agricultural); 4,057 km<sup>2</sup> of range-lands (mostly State land); and 10,539 km<sup>2</sup> of National Parks and Game Reserves (mainly the Tsavo). The Chyulu Game Reserve is intended to be an extension of Tsavo West National Park. The rest of Tsavo National Park is in Kitui and Tana River District and 449 km<sup>2</sup> is covered by either rocks or lakes. Some 1,323.5 km<sup>2</sup> of agricultural land are mainly used by small-scale farmers.

---

<sup>1/</sup> Details of wind (including monsoonal effects) and current regimes influencing the coastal climate are excellently summarized in UNEP Regional Seas Reports and Studies No. 12, as are mean barometric pressures and mean sea surface temperatures and are therefore not repeated here.

Agricultural crop-land in the Kwale District covers some 1,910 km<sup>2</sup>, marginal lands account for 1,310 km<sup>2</sup>, range-lands 4,547 km<sup>2</sup>, Shimba Hills National Reserve and forest 350 km<sup>2</sup>, marine and beach areas and rocks 205 km<sup>2</sup>. The Shimba Hills is the only gazetted National Reserve (proposed as National Park) covering some 192.51 km<sup>2</sup>. The Mpunguti Marine National Reserve and the Kisite Marine National Park cover a water area of some 23 km<sup>2</sup>.

Kilifi District has some 1,040 km<sup>2</sup> of high potential, 2,470 km<sup>2</sup> of medium potential, 2,580 km<sup>2</sup> of marginal, and 6,500 km<sup>2</sup> of low potential lands. The low potential and marginal lands are mainly used for livestock, as agriculture is only marginally possible. The bulk of the land in Kilifi district is still under-utilized. Coastal lands and parts of the south are relatively cultivated at subsistence and almost invariably, sub-optimal levels. The only important national reserve is the Malindi/Watamu National Reserve covering some 213.7 km<sup>2</sup>.

Mombasa, principally a metropolitan area, has about 204 km<sup>2</sup> of township. An area of 65 km<sup>2</sup> is under water and only 3 km<sup>2</sup> is government reserve and land. Another 3 km<sup>2</sup> is trust land available for small-holder registration. The most important features in Mombasa include a good natural harbour and a modern international airport both linking the country to the rest of the world.

Lamu District has approximately 6,581 km<sup>2</sup> of government land (including 308 km<sup>2</sup> of open water and 161 km<sup>2</sup> of forest and other/government reserves); 184 km<sup>2</sup> of trust land and 49 km<sup>2</sup> of freehold land. Some 300 km<sup>2</sup> have been earmarked for agriculture, 2,480 km<sup>2</sup> for ranching, 1,493 km<sup>2</sup> for forestry and 877 km<sup>2</sup> for game reserves. There are two important national reserves, the Dodori River Game Reserve and the Kiunga Marine National Reserve.

#### Agricultural production

From an analysis of land utilization (large farms) by various crop types (cereals, temporary industrial crops, root crops and vegetables, temporary fodder crops, temporary meadows, permanent industrial crops) a number of salient features related to coastal agriculture can be drawn.

The principal cereal crop is maize grown chiefly in Kilifi where 101 ha were planted in 1980 out of a total cereals hectareage of 134 and a national hectareage of 79,378. Among the temporary industrial crops (sugar-cane, pyrethrum, sunflower, etc.) only suger-cane is grown at any level of significance, mainly in Kwale where 5,295 ha were planted in 1980, compared with a national hectareage of 37,397. The Taita Taveta District grows a significant amount of root crops and vegetables (43 ha), as does the Kilifi District (29 ha) and parts of Kwale (9 ha), compared with a national total of 2,435 ha. Temporary fodder crops are important in Kilifi (48 ha) and less so in Kwale (13 ha) with a corresponding importance of temporary meadows-66 ha and 21 ha respectively for Kilifi and Kwale; national total:87,977 ha. The Kilifi district grows a number of other temporary crops in significant amounts.

Among the permanent industrial crops the most important in terms of land use is sisal grown mainly in Taita, where 49,858 ha were planted, and to a much lesser extent in Kilifi (4,541 ha), compared with a national total of 82,503 ha. Next in importance is coconut grown chiefly in Kwale (601 ha), but also in Kilifi (317 ha), comparing with a national total of 918 ha. Coffee is grown mainly in the Taita-Taveta district - 282 ha, and in Kwale - 75 ha, (national total - 29,403). Cashew-nuts and pineapples are also grown in the coastal region, in Kilifi (333 ha; 192 ha) and in Kwale (682 ha; 38 ha) national totals being 1,016 ha and 1,349 ha respectively.

Thus it can be seen that, with the exception of sisal, coconuts, cashew-nuts and to a lesser extent pineapples and a lot of sugar-cane, large farms on the coast cannot be said to be making a very significant impact on the agricultural production of the nation. The reason for this is, perhaps, the very great proportion of low potential land in the coastal region (5,663,000 ha) compared with medium potential (373,000 ha) land which, together with all other land (1,472,000 ha), makes a total of 8,304,000 ha. These figures compare rather unfavourably with the national totals of high potential (6,785,000 ha), medium potential (3,157,000 ha) and low potential (42,105,000 ha) for the purposes of agriculture. There are, however, other provinces, e.g. the eastern and north-eastern which compare even less favourably.

Other crops grown mainly at a subsistence scale include mangoes, bananas, cassava, sorghum, rice, pigeon peas, cow-peas and citrus fruits. Cotton-growing is also gaining some momentum especially in Lamu district and the cooler reaches of the Taita Hills.

Comparable data on small farms are not readily available but it can safely be assumed that they follow more or less a similar pattern, bearing in mind the fact that currently, on a nation-wide scale, small farms constitute slightly more than 53 per cent of gross marketed production, even if no account is taken of the difference in productivity and marketing efficiency between the large and small farms.

The quantity (2,395,400 kg) and value (KSh. 2,995,500) of coastal small-holder farm inputs including fertilizers, sprays, feeds, etc. are the lowest in the country (ignoring north-eastern Province) and also compare unfavourably with the national totals of 169,600 kg and KSh. 387,257,600. Observers think that quite apart from the nature of the land, the character of the coastal climate is such as to make the coastal inhabitants not particularly active in agriculture, with the majority of the people engaged in fishing and "philosophizing".

## POPULATION AND HUMAN SETTLEMENTS

### Population distribution

Data from the 1979 population census indicated that the coastal population numbered 1.34 million, living in 270,000 households, which gives an average of about 7.8 persons per household. Of these, approximately 665,000 were female and 677,000 male, representing an interesting departure from the national population distribution by sex in which proportionally 772,000 were female and 761,000 were males for a total national census population of approximately 15.33 million.

This coastal population lives in an estimated 830,400 km<sup>2</sup> giving an average population density of 16 persons per km<sup>2</sup> compared with a national average of 27 persons per km<sup>2</sup>. The Tana River district, covering some 38,694 km<sup>2</sup>, had a particularly low density (2 persons per km<sup>2</sup>); and given the fact that most of the district lies away from the coastline, this provides a definite skew of what might be referred to as a strictly coastal population. This is borne out by the fact that Kilifi and Kwale districts both have a density of 34 persons per km<sup>2</sup> with Taita Taveta and Lamu having densities of eight and six persons per km<sup>2</sup> respectively. Kilifi is the most populous of the districts (with 431,000 people) followed by Kwale (288,000); Taita Taveta (148,000); Tana River (92,400) and Lamu (42,300). Mombasa urban district is in a class of its own with 341,000 inhabitants living in a land area covering 210 km<sup>2</sup>, giving a density of 1,622 persons per km<sup>2</sup>, the highest in the Republic (Nairobi has a density of 1,210 persons per km<sup>2</sup>).



About one third of the coastal population is below the age of 10 years and about one half is below 15, a characteristic that roughly accords with the national age distribution. Approximately 16 per cent of the population attend school while another 19 per cent have completed school; this leaves about 65 per cent who have never attended classes, of whom some 18 per cent are children below the age of five. This points to fairly poor literacy, where an estimated 47 per cent of people above the age of five have never attended school; a factor that has no doubt contributed to relative lack of development in the coastal region.

By far the largest ethnic grouping on the coast is the Mijikenda group living mainly in Kilifi (390,900 persons); Kwale (236,480), and Mombasa (87,860). Lamu is inhabited chiefly by the Bajun ethnic community (19,370 persons), Taita Taveta by the Taita (112,000) and the Tana River by the Pokomo (32,540), and the Orma (30,600). Small numbers belonging to many other coastal ethnic communities inhabit the region (e.g. 46,000 Boni-Sanye in Mombasa while the rest of the community is made up of immigrants, chiefly the Kamba and some Kikuyu from up-country regions (Mombasa alone has 40,350 Kikuyu, Kwale and Lamu 9,060).

The total fertility rate for the coast province is the second lowest in the country (7.08 per cent per annum) after Nairobi (5.48). The percentage of children dying in the first two years is the second highest (17.35) after Nyanza (18.45). Life expectancy at birth is the second lowest (48.90 years), then Nyanza (47.35).

#### Population migration patterns

Migration pattern figures indicate no significant movement in or out of the Taita Taveta district. What little migration there is (to Mombasa and Nairobi) is mainly temporary and by males in search of employment opportunities; it has tended to increase with the rise in the level of education.

In Tana River district, considerable internal migration is to be noticed among the Orma who are a pastoralist community that moves from place to place within the district in search of pasture. The other major migration pattern has been promoted by the Bura Irrigation Scheme which will settle some 5,150 families (one family unit = six persons) drawn from landless people throughout Kenya. Over 70 per cent of these immigrants will be drawn from outside the Coast Province and these, together with government and other employees in the scheme, will cause an overall increase of 37 per cent to the population of the district as a whole. A number of irrigation schemes along the Tana River are causing increasing internal migration towards the river bed, and have also attracted a small proportion of immigrants from outside.

The chief immigrants in Kwale district have been the Kamba from Machakos and Kitui districts, as well as Kikuyus who came from Tanzania after the break-up of the East African Community. It is estimated that about 20 per cent of the district's population is migrant the bulk of which (about 14 per cent) constitutes immigrants from the rest of the country outside the Coast Province. There is also significant rural-to-rural migration among people searching for arable land in the district.

In Kilifi, the Malindi township, due to its urban character and tourist potential, has attracted large numbers of immigrants and itinerants. The Majarini and the Lake Kenyatta Settlement Schemes have attracted a large number of up-country settlers. The special character of Lamu with its wealth of historical sites and monuments attracts a large number of tourists. The planned development of a second port at Manda Bay is likely to enhance worker migration to Lamu.

Mombasa is a metropolitan municipality which attracts many up-country workers and a large proportion of indigenous and foreign tourists. There is a significant pattern of rural-to-urban migration caused mainly by the search for employment in the major urban areas, especially Mombasa, Voi and Malindi, fuelled by both the urban "bright lights" and the booming coastal tourist trade. This fact is borne out by relatively high population growth rates ranging between 6 and 7 per cent per annum, the national population growth rate being 3.8 per cent per annum.

#### Urban population

Projections by the Physical Planning Department indicate that Mombasa's population, currently under half a million will grow close to, if not rise above, the million mark by the year 2000, while that of Malindi (currently just above 20 thousand) will grow to about 80 thousand, and that of Voi will grow from 9.5 thousand to about 28 thousand. The projections indicate that Lamu is likely to grow at a much slower rate (3 per cent) from about 10,000 to 15,000 population.

The other urban centres include Kilifi with a population of 4,800, Mariakani (2,000), both in Kilifi district, Kwale and Kinango (2,200 and 4,500) both in Kwale district, Lamu in Lamu district (9,700), Wundanyi in Taita Taveta district (7,900) and Hola in Tana River district (4,600).

The overall trend of relatively higher urban growth rates vis-a-vis rural growth rates on account of rural-urban migration is to be observed throughout the Republic, as in many other developing countries, where current populations are chiefly rural. A comparison of the above urban centre populations with the total Province population figures given earlier bears out the assumption that the coastal population is mainly rural.

#### Housing

There is an acute housing shortage in urban areas throughout the region and rural housing is generally of a particularly poor standard. In some areas of Taita Taveta, where land was not traditionally handed down through inheritance, the land is owned by no one. Improvements via the building of permanent houses is not a practical proposition. In the Tana River district, most rural houses are temporary structures, especially those put up by the pastoralist Orma. The Pokomo build semi-permanent structures mainly due to lack of stones and trees.

In Lamu district modern permanent buildings with a touch of traditional design are now seen, especially in Lamu township. "Makuti" houses (Makuti roofs, mud walls reinforced with coral rocks and mangrove poles) are found in all main centres, such as Lamu, Shella, Matondoni, Mokowe Mkunumbi, Mitu, Faza, etc. These Swahili-type houses are generally built too close to one another and their Makuti roofs pose fire hazards as evidenced by the Lamu fire disaster of 1981/1982. In most of the designated centres in the adjudicated areas of the Kwale district, land is registered under individual names, leaving very little land for public utilities such as housing construction within the centres.

The situation in Kilifi district is much the same as in Kwale district except that in the former, Malindi town with its metropolitan-type characteristics has a distinct modern housing character and shares an acute housing problem with other urban centres in the province and the country in general. In 1982/83, the National Housing Corporation earmarked KSh. 37,700 for housing development and KSh. 18,400 for rural housing development.

In general, the need to develop housing types of good quality and related infrastructure is as urgent in the coastal region as anywhere else within the country. It should be recognized that good housing, in addition to providing backward linkages to the building industry, also provides forward linkages to those sectors of the economy to which good human health and well-being accord higher efficiency.

Apart from games of football and the well-developed Ngoma dancing in certain tourist centres, and also some boating mainly by tourists and holiday-makers, the recreational infrastructure and services in the coastal region are poorly developed. The proposed coastal zone management project will, among other things, seek to promote the development of good quality, inexpensive building materials for use by the coastal people. It will also seek to promote various aspects of active and passive recreation and develop attendant infrastructures.

#### Historical sites and monuments

The other significant feature of coastal human settlements is the legacy from antiquity of a wealth of historical sites and monuments. These include unoccupied sites with isolated ruins of houses, mosques and tombs (e.g. at Ishakani) and sites covering ruined townships, fortified areas and enclosures (e.g. at Takwa and Gede); remains of past habitation in areas still partially occupied (e.g. at Shela and Pate); urban areas of historical and architectural importance (e.g. Lamu, Mombasa Old Town); and monuments in established town or village environments (e.g. Vasco da Gama Pillar at Malindi). The existence of these historical sites and monuments bears witness to the fact that the East African Coast has been an area of important settlements for many centuries. It is estimated that there is a total of 70 historical sites and monuments along the coast, 58 of which have been gazetted as national monuments. Many of these monuments have remained intact due to their location in thick bushlands and along the sea-shore.

Historical sites and monuments play a significant role in tourism as evidenced by the 141,000 visitors to Fort Jesus in 1980. Possibly, their importance as a tourist attraction is closely related to the existence of other tourist facilities, so that their conservation and restoration should be considered within the context of overall tourist infrastructural development. Their cultural, archaeological, palaeontological and educational value is an added incentive to their preservation, a policy that is being actively pursued by the Physical Planning Department, the National Museums of Kenya and the National Environment Secretariat. The success of these conservational objectives, however, will depend on the extent to which trained manpower, financial resources and equipment can be made available within the framework of a truly robust conservation programme.

#### HEALTH, SANITATION AND WATER SUPPLY

Kilifi District has some 36 health facilities composed of six health centres, one sub-health centre and 29 dispensaries. Four major water supply schemes at Mazeras/Jaribuni, Texo-Roka, Kilifi and Canda-Watamu serve an estimated 22,500 people, while the Malindi Urban Water Supply serves some 8,500. The Kilifi County Council operates 17 boreholes, nearly all of which have mineralized water; and half of them are not operating due to poor maintenance. The majority of the population along the coast still depend on small dams, water holes and wells. There is an estimated total of 150 small dams, most of them constructed during the 1950s and now badly silted up.

Kwale District has three hospitals (with resident doctors); only the one at Msambweni is rated as a district hospital. In addition, there are three health centres and 20 dispensaries. There is one doctor for every 100,000 people. An active public health campaign is in force covering such areas as environmental sanitation, communicable and vector-borne disease control, malnutrition and family planning as well as the development of small-scale water supplies. Sewage disposal systems are available on a small scale, only in centres such as Kwale, Kinango, Ukunda and Msambweni.

The Pemba, the Umba and Mwachi rivers are the only reliable sources of water in the district. There are a number of streams and rivulets running from the Shimba Hills whose water supply, although constant all year round, amounts to a very low daily flow. Small earth boreholes and wells make a poor addition to the total water supply in the District. There are about 20 water supply facilities, sponsored by different agencies, serving an estimated 20,000 people in the district.

Lamu district has only one (district) hospital with 33 beds at Lamu township; there are 10 dispensaries and Witu and Faza have two health centres. A flying doctor service supplements these medical facilities with monthly flights and mobile clinics but not to an adequate level of health service. The Lamu Water Supplies project maintained by the Ministry of Water Development and serving 12 thousand people in Lamu township, Shella on the Island, Mokowe on the mainland and Ras Kitau on Manga Island, is about the only successful water supply scheme in the district. Water is pumped from wells in sand-dunes on Lamu Island. There are a number of other water schemes at Mokowe, Witu, Hindi Prison, Bargoni Holding Ground and Lake Kenyatta Settlement Schemes.

The Taita-Taveta district has three government hospitals at Voi, Taveta and Wesu, four health centres at Mpizinyi, Nyache, Mbale and Mwakitau, a sub-health centre at Wudanyi and 16 dispensaries. There are also three institutional health facilities at Mwatate, Bura and Ziwani and one private clinic at Manyani. Sanitation standards generally leave much to be desired and there is an urgent need to initiate rural water supply programmes, and to provide more pit latrines for homes and public places.

Three rivers, Voi, Lumi and Tsavo supply water to various parts of the district. Other sources are negligible making it difficult to centralize the water supply. Most of the sources are to be found in the Taita Hills, Sagalla Hills, Taveta Kisagau, and Lake Jipe. Generally, many families walk long distances to seek water (as far as 6 km). There are three minor urban water supply schemes at Wudanyi, Taveta and Voi.

The Tana River district has three hospitals at Hola (district hospital), Kipini (sub-district hospital) and Ngao (missionary hospital), making a total of 144 beds served by two doctors. This gives a ratio of one doctor to 46,200 people and 1.6 beds per thousand population. There are also 14 dispensaries, 13 of which are along the River Tana, and two health centres at Garsen and Mavaro.

Only about one quarter of the district population has access to treated water, the rest using raw water from rivers (mainly the Tana) and wells. Poor sanitary facilities gave rise to a cholera outbreak in 1970/71 and an outbreak of dysentery in 1977. The impact of stagnant water in irrigation schemes has also had a telling effect on health; a survey carried out among tenants of the Hola Irrigation Scheme revealed that 90 per cent of the people had bilharzia.

Water development programmes for both human and livestock consumption are perhaps the most important aspect of development in the district because of its arid conditions. Ongoing water supply projects during the 1979-83 development plan period included two major schemes at Ngao/Tarasaa and at Bura, and minor projects at Wenje, Mnazini, Kipini and Mbalambala. A number of rudimentary wells have also been constructed. The absence of a well-developed water development programme can perhaps be attributed to the abundance of water flowing in the Tana River which induces some degree of complacency and inertia in the initiation of such activities.

The provision of potable water supplies is urgent to fulfil the population's basic water needs and to help improve the health of the people.

### COASTAL INDUSTRIAL DEVELOPMENT

The 1972 Census of Industrial Production indicates that primarily due to the existence of Mombasa as the second major town in Kenya after Nairobi, the Coast Province comes second only to Nairobi Province in terms of aggregate industrial output in manufacturing, building and construction and in the mining and quarrying sectors, all contributing a total of KSh. 16,118,500 to the gross domestic product (nationally these industries contribute a total of KSh. 97,056,600 to the GDP). Mombasa's contribution alone totals some KSh. 15,368,100, which suggests that little other industrial development has taken place in the coastal zone except for Mombasa.

The manufacturing sector, employing some 17,128 persons, is by far the most important of these categories, with the building and construction trailing a poor second with 2,897 employees, and the mining and quarrying industry third with 514.

The major industrial activities in Mombasa include the oil refinery, cement manufacturing at Bamburi, dry-dock for repairing large ships, textile factories and various engineering works. The major industrial environmental threat takes the form of water and air pollution from the refinery, although the impact of the textile industry and a number of small concerns manufacturing detergents, galvanized pipes and corrugated iron sheets, and plastics, among others, cannot be ignored. The Bamburi Cement Factory, while also a potential cause of air pollution, is perhaps one of the best examples of a properly managed industrial enterprise from the point of view of environment protection.

Other important industries include the Ramisi Sugar Factory in Kwale and the Cashew-nuts Processing Factory at Kilifi, both employing over 3,000 persons. The latter employs mainly females due to the nature of its operations. Beer and soft-drink manufacturing concerns are also of interest as is the proposed coconut oil extraction enterprise in Kilifi town.

The Coast generally has good potential for further industrial development. The future growth of industrialisation will probably be closely linked with the growth of agriculture which, as we have already seen, definitely requires a tremendous impetus to take off in any appreciable way. The development of infrastructure in areas other than Mombasa will also play a critical role in determining the pace and pattern of further industrialization in the region.

## COASTAL TRANSPORT INFRASTRUCTURE

### Roads

Most of the roads in Mombasa district converge in Mombasa town due to its importance as an industrial and commercial centre. The district is relatively well served by both classified and unclassified roads, although the network is unequally distributed, with many of the roads concentrated in the Mombasa/west mainland axis leaving the north/south mainlands with few motorable roads, a factor that has contributed to the relative underdevelopment of these parts. A number of developments are currently being implemented to redress this situation.

The Kwale district has a total of 1,097 km of classified roads serving 187 persons per kilometre of classified roads as compared to 282 persons per kilometre of access and other loose surface roads. The district is divided into two unequal parts by the Lunga Lunga - Kihangu Silaloni road with one third lying to the western side and being served by unclassified roads. The remaining two thirds on the eastern side is well served by classified roads, being more densely populated and economically more significant. The district has some 185 km of agricultural access roads (earth and gravel); 141 km of marginal lands access roads; and 257 km of rangeland access roads (earth roads which become impassable during the wet season).

The road network in Kilifi comprises 980 km of classified and 1,692 km of unclassified roads. Nearly all the roads are impassable during the wet season. The level of maintenance has been rather inadequate or totally lacking except for a modicum of Harambee effort.

Tana River district has 1,200 km of classified roads comprised of 200 km of national roads, 80 km of trunk roads and 920 km of secondary and minor roads. The roads are practicable mainly during the dry season.

There are 454 km of classified roads in Lamu district which are generally loose-surfaced. The only all-weather roads are the Mokowe Jetty Boundary road and the Wity-Kipini road which are murrum-surfaced, the others having black clay soil surfaces.

Taita Taveta district has 925 km of classified roads of which 222 km are tarmacadamed and the rest have an earth surface. There is a total of 780 km of unclassified roads.

It is estimated that nearly three quarters of goods exported and imported through the Port of Mombasa are conveyed by road underlining the critical importance of this mode of transport. The oil pipeline is gaining increasing importance in the transport of oil products previously handled by road and rail. It is estimated, for example, that some 337,487 m<sup>3</sup> of regular motor spirit, 102,886 m<sup>3</sup> of kerosine, 417,813 m<sup>3</sup> of light diesel and 402,127 m<sup>3</sup> of jet fuel were conveyed via the pipeline in 1980, with comparable figures in 1979 and 1981.

### Rail transport

Rail transport between the coast and up-country regions is still important in the handling of both passengers and freight. The main railway line between Mombasa and Nairobi branches at Voi to connect with Taveta town. Kenya Railways has a large depot in Mombasa from which lines extend to the industrial area and the port warehouses. The Mombasa marshalling yard handles about 1,000 units of rolling stock

and another yard under construction in Changawe will handle about 1,500. It must be emphasized that the Mombasa-Nairobi rail link is very important, perhaps the most important in the whole railway system in Kenya, although the Nairobi-Kisumu section cannot be ignored.

Rail and pipeline transport help to take pressure off the roads and thus prolong their usefulness. However, they are unlikely to become as important as the road system in the foreseeable future.

#### Sea transport

Mombasa, the most important port on the Kenyan Coast (perhaps the best known along the whole East African coast) has derived its viability not only from its strategic position as an entry point with a natural harbour but also because of the existence of an extensive and reasonably productive hinterland projecting beyond Kenya to Uganda, Rwanda, Burundi and Zaire and, until recently, parts of Tanzania and Zambia. Considerable construction of wharfs, berths and jetties and a fair amount of dredging of the entrance channel to allow entry and exit of large vessels were carried out between 1979 and 1983 which will further improve the capacity of the port to connect Kenya to the rest of the world via the sea. A container traffic system is now operational at the port.

The second best natural deep harbour site occurs at Manda Bay in Lamu. This site currently handles medium-sized ships and big dhows operating between Mombasa-Malindi and Lamu and also between Lamu and the Persian Gulf and South Arabian countries. Plans are under way to develop the harbour to handle large vessels. There are a number of other relatively minor ports to be found along the coast especially at Malindi, Kilifi, Mida, Mtwapa and Ngomen creek.

During 1980, 1,453 steamships and 79 sailing ships entered Kenya through the port of Mombasa. Lamu handled 130 sailing ships. Other ports along the coast handled 225 steamships and 53 sailing ships. These vessels had a total registered tonnage of 6,322,000 and transported 143,800 metric tonnes and 199,000 metric tonnes of dry cargo (exports and imports respectively), as well as 598 metric tonnes and 3,587 metric tonnes bulk of petrol and oil. With regard to passengers, 556 embarked and 157 disembarked during the year, a considerable drop from past years, attributable, perhaps, to the relatively growing importance of air transport.

#### Air transport

The principal airport on the coast is the newly constructed Moi International Airport built next to the site of the old Mombasa airport. The old terminus with four parking bays is now used for light aircraft and chartered cargo planes. The new terminus, with six parking bays and two principal terminal aprons, can land modern jets of any weight, including wide-bodied aircraft. During 1980, 178,000 landing and 182,000 embarking passengers were registered at Mombasa; 16,492t of landed cargo and 10,200t of loaded cargo were handled; 86t of mail were landed, 38t were loaded.

The Malindi airport is the only other airport with tarmac runways and terminal facilities and can accept aircraft of the DC-9 type and slightly bigger. It has been very useful for tourists, especially those originating from the Federal Republic of Germany, who seem to prefer to fly directly to Malindi with only brief stopovers in Nairobi.

There are numerous airstrips of various standards around the coast capable of taking light aircraft, the chief among them being located at Kilifi and Mnarani Club in Kilifi district; Kiunga, Mokowe, Manda and Witu in Lamu district; Mackinnon road, Ramisi, Diani, Shimba Hills National Reserve and Wasini Island in Kwale district; Taveta, Mwatate, Voi, Mtito Andei, Kilaguni, and Aruba in Taita-Taveta district; and Garissa, Galole and Garsen in Tana River district.

The increased importance of air transport, especially from Nairobi to Mombasa and Malindi and also within the coastal region, is promoted by, among other factors, the increasing cost and length of time required by other modes of transport and the absence of an efficient road and rail network that could be used all year round.

#### Impact of transport systems on ecosystems

The effects may be summarized as follows:

- demolition of the natural environment during road and railway construction, causing destruction of communities in the ecosystem;
- noise pollution caused by construction machinery, vehicles, aircraft and ships;
- pollution of rivers with silt resulting from erosion of disturbed soil from formation slopes and embankments during construction. This is deposited in the sea as sediments which suppress coral communities. On the other hand, deposition of sediments encourages the growth of mangroves on the silt deposits;
- exhaust gases produced by vehicles, aircraft and ships which pollute the air;
- pollution of sea-water by oil from oil spills causing death to marine life;
- dredging and extraction of building materials for harbour construction: dredged areas form a layer of sand which provides little chance for attachment and survival of coral larvae. The suspended sediments in the dredged areas smother the coral and other reef organisms.

#### TOURISM AND TOURIST INFRASTRUCTURE

Another specifically coastal resource is the great number of natural beaches which have been a major tourist attraction in Kenya, rivalled only by the system of national parks and game reserves.

In the section of the coastline between Vanga and Malindi most beaches are characterized by a raised coral reef foreshore occasionally receding to a maximum of 200 m from the high water mark and allowing the formation of a sandy area replete with coconuts and other coastal tree-crops. Coral reefs protect most of these beaches from the main ocean waves.

The area around Malindi and to the south has suffered as a result of the silt discharge from the Sabaki river which, apart from disrupting coral formation north of the Vasco da Gama Pillar, has also caused concern to people interested in Malindi as a resort, because of the destruction of beaches by silt. South of the Vasco da Gama Pillar, at Silversand, the beach is unaffected by silt. Further south, about 6 km outside the town boundary, there is a fine, white sand beach. However, there are about 16 km of coastline affected by the Sabaki silt, which unfortunately is the area where most of Malindi's hotels are located.



The Watamu resort has about 8 km of fine beach. For the most part, the foreshore is sandy but two coral headlands divide this beach into three sections known from north to south as Watamu, Blue Lagoon and Turtle Bay. These beaches are terminated by Mida Creek to the south and there are one or two small beaches, about 2 km long, at the mouth of the Kyombo creek.

The beaches at Kilifi measure about 5 km in length between Kilifi Creek in the south and Horne's Point in the north. The foreshore is generally sandy and the beach attractive. A few beaches of minor significance occur between Kilifi and Watamu. A number of discontinuous beaches are found between Kilifi and Mtwapa; at Takaungu, the beaches are 3 km long; at Kikambala/Kanamai 8 km, and at La Mtwana 500 m.

The beaches are without a doubt the most significant social and economic asset of the coast without which the growth of the tourist trade (both external tourists and internal up-country holiday-makers) would certainly not have been as significant as it is today.

In Kenya the growth of beach holidays has averaged 20 per cent per year over the past 15 years or so and it is projected that the growth will continue at approximately 9 per cent per year (studies by Kenya Coast Planners Ltd.). The number of beach hotels and the bed occupancy rate have increased with the growth of the tourist trade. The number of visitors to marine parks rose from 16,200 in 1968 to 37,200 in 1977. The beach bed occupancy almost doubled between 1973-77 from a figure of 812,500 to 1,543,900. During this period, the number of coast hotels grew from 52 to 61, twelve of which are in Mombasa (figures from the Hotel Licensing sectors of the Ministry of Tourism and Wildlife). Such significant growth rates are made possible not only by the attractiveness of the Kenya coast but also by government policy to promote tourist trade as a major earner of foreign exchange.

The necessary infrastructure for the promotion of tourism has been well developed, with the Kenya Tourist Development Company playing a leading role, especially in the promotion of hotel construction. A number of tourist "circuits" have also been promoted and the beach hotels are linked by both the Mombasa-Tsavo-Amboseli-Mombasa circuit and the Mombasa-Malindi-Lamu-Tana River-Primates-Mombasa circuit. Another emerging but less developed circuit will link Mombasa-Tana River-Lamu with Garissa and the Meru National Park.

Due to the links between coastal tourist attractions and up-country facilities, such as game reserves and national parks, it is difficult to distinguish between tourists motivated by the coastal environment and those interested in the wildlife. Since most of the tourists are holiday-makers, it is likely that many wish to enjoy both facilities. Historical sites and monuments along the coast, some dating as far back as the days of Vasco da Gama in the 15th century A.D., also serve as important tourist resources.

In addition to the development, conservation and management of such tourist attractions, the development of linkages with the existing national parks and game reserves both in the coastal region and elsewhere in the country, as well as the maintenance of a viable political economy, will determine the extent to which tourism will continue to play a vital role in the Kenyan economy.

Along the coast there is a steady increase in poaching which is a danger to animals of different species. This brings up the critical question of protecting the selected species or classes of marine animals wherever this deserves serious consideration, especially with regard to the collection of corals and molluscs, which are sold as tourist souvenirs; the latter is used locally for food.

Tourism, while providing much needed foreign exchange to the nation, is not without its own negative side-effects. These are associated with "socio-cultural pollution" caused by the introduction of cultural tenets and a social system that is basically foreign to and incompatible with traditional coastal culture. The Arabic phase of cultural pollution has come and gone with "Mediterranean" values and religion, having been integrated, to a large extent, with the coastal "Swahili" culture over centuries. The second phase takes the form of up-country cultures mixed with western traits which are taking root in the coastal region. The socio-economic linkage has tended to enhance the trend of prostitution which is increasing along the coast. Other situations emerging from such influences are the great demand for the coastal "ngoma" dance, which encourages children to leave school in order to earn a small living from performing the commercialized form of this celebrated art, and the turning into a "gigolo" of a number of young men.

## FISHERIES, CORALS AND MANGROVES

### Fisheries

One might expect that, given the expanse of the coastal waters, the coastal zone would account for the greatest volume of landed fish in the country. Available statistics, however, indicate that freshwater fishing is far more important especially in Lake Victoria in Nyanza and Lake Turkana in the Rift Valley provinces. During 1980, 43,000 metric tons of freshwater fish were landed, valued at KSh. 4 million, as compared with 5,000 metric tons of marine fish valued at KSh. 1.2 million. These figures indicate that marine fish are more than twice the value of freshwater fish, perhaps because of the beach hotel market. It should be noted, however, that artisanal fishing is quite important along the coast and since this it not likely to have been included in the statistics, the actual volume of fish caught in the coastal region is much higher. Nevertheless, these figures point to the fact that both commercial and artisanal fishing is grossly underdeveloped and is an industry that deserves to be given considerable impetus, something with which the Coastal Zone Management Project is concerned.

Mombasa accounted for 1,800, Lamu 1,400, Kwale 650, Kilifi 600 and Tana River 100 metric tonnes of fish landed during the year. Sport fishing accounted for some 356 metric tonnes of landed fish. A total of 400 metric tonnes of crustaceans were also landed, with Mombasa accounting for 200, Lamu 100, Kwale 50, Kilifi 45 and Tana River 5 metric tonnes, all valued at KSh. 340,000. Other marine products accounted for 31 metric tonnes landed, valued at KSh. 9,400, including oyster, game fish, oyster shell grit, bêche-de-mer and squid.

As indicated earlier, two principal methods of fishing are used - industrial and artisanal. Industrial fishing employs sophisticated fishing gear and is mainly carried out by the Fisheries Department, a number of fishing co-operatives, local fishing firms and some foreign-owned firms registered in Kenya. The Government, in a bid to develop this large-scale fish production, entered into a joint venture with the Industrial Commercial and Development Corporation (ICDC - a para-statal body) and Japanese financiers, with the aim to control fishing in the economic zone waters (Kenya has already declared a 200-mile economic zone). This three-phase endeavour involves in its final phase the construction of a fish processing complex for fish canning and fish meal production. There is an estimated total of 7,664 fishermen and 945 fishing co-operative members on the coast. Co-operative fishing and artisanal fish marketing have yet to be developed sufficiently enough to eliminate

such problems as the exploitation of fishermen by middle tradesmen, who buy fish at very low prices from the fishermen and sell to large-scale consumers at fairly high prices; the dearth of storage facilities and lack of adequate landing jetties which could be used by local fishermen are also important constraints in this industry.

By far the most important wet fish resources are the demersals which account for just over half the tonnage of fish landed. Pelagic fish and sharks account for a total of about 20 per cent, the rest being made up of mixed species. Among the crustaceans, the spiny lobsters, prawns, and crabs are the most significant, making up approximately 25, 20 and 15 per cent of total tonnage landed. Some freshwater fish such as Tilapia, Barbus and clarins occur at the river mouths especially at the mouth of the Sabaki and Tana. Demersals, crustaceans and molluscs are found along the lagoons and coastal waters not far from the shoreline, generally on the stretch of the continental shelf which extends some 10 nautical miles from the shoreline. Pelagic fish and sharks are found in the deep sea.

Three marine National Parks have been established, one in the Kisite/Mpunguti area on the south coast and the others at Malindi and Watamu on the north coast. The Marine National Reserve between Malindi and Watamu has been designated a Biosphere Reserve under UNESCO's Man and the Biosphere (MAB) Programme. The principal objective of these parks and the reserve, which fall under the jurisdiction of the Wildlife Conservation and Management Department, is to promote the protection, restoration and perpetuation of species of marine life. This would provide for the protection of breeding grounds, areas which also serve the interests of research and education in matters related to marine biology.

The Kenya Marine Fisheries Research Institute, an off-shoot of the East African Marine Fisheries Research Institute operates under the auspices of the Fisheries Department and carries out research aimed at identifying fish species and stocks, their ecology, biology, distribution, relative maturities and abundance, in order to facilitate the promotion of policy geared to the determination of optimal, economically viable and sustainable yields of the stocks, given currently accessible levels of harvesting technology. The research institute is presently facing severe operational problems due to the lack of personnel and equipment, including scientifically equipped sea-going research vessels. This is one of the areas where international assistance could be most valuable within the East African Regional Seas Programme.

#### The coral environments

The coral reef runs roughly parallel to the Kenyan coast at distances ranging from 500 m to 2 km from the shoreline. The north coast, which extends from the town of Malindi to the Somali border, is characterized by seasonal flooding of the rivers Sabaki and Tana; this has affected adversely the formation of coral reefs. Between Malindi and Mombasa on the other hand there is an almost continuous coral formation thanks to which, among other factors, two marine parks and a marine biosphere reserve (the Malindi-Watamu Biosphere Reserve) are located there.

Considerable coral reef formation has taken place on the south coast although the occasional flooding of the rivers Umba and Ramisi has tended to restrict it. The effect of the East African south-easterly current appears to have diminished such sedimentation and restricted the formation of sand banks, thus making it possible for coral reefs to develop along a greater part of the south coast.

Coral reefs are one of the finest examples of a biologically productive, taxonomically diverse, stable and aesthetically celebrated environment, forming a system of intricate interrelationships - an environment that is a 'masterpiece' of

the symbiotic relationship between various organisms. Reefs are extremely useful breeding grounds for fish and their destruction has significant socio-economic impacts, for fish are an important source of income and protein. Coral sand is also useful construction material for local dwellings due to its hard texture. This has led to the destruction of live corals, albeit on a small scale. Dead coral, mainly terrestrial, is used in the manufacture of cement, notably by the Bamburi Cement Factory, and is a useful economic resource obtained at minimal cost. The many uses of corals point to a need for their protection and use on a sustainable basis.

One of the greatest dangers to coral environments stems from siltation from river mouths due to flooding. This is usually caused by improper cultural practices along rivers, especially the Sabaki. The solution to such practices lies as far upstream as the Athi-Tana basin immediately adjacent to the source of these rivers. This is an example of a socio-economic problem that begins many miles from the coast but which noticeably affects the coastal zone. Another threat to the coral habitat emanates from oil pollution, especially by ocean-going tankers, due to the proximity of the Kenyan coast to major world sea-lanes. This, and the impact of dispersing agents such as detergents from industrial and domestic washing, have the effect of altering the dissolved oxygen content of the waters, thus adversely affecting the organisms, especially fish. The hard terrestrial coral environment has also militated against tree planting or made it very expensive, especially in parts of Kisauni and Likoni.

The complex coral environment needs to be studied in greater detail in order to establish its full socio-economic potential and to find the most effective methods of protecting it from the attending environmental hazards. The Kenya Government, through the National Environment and Human Settlements Secretariat, has initiated a Coastal Zone Management Project with this as one of its major objectives, the findings of the project to be fed into the later stages of the East African Regional Seas Programme.

#### The mangrove environments

Along with the coral reef, the mangrove forests are another significant and distinctly coastal resource. Mangroves are basically estuarine, thriving as they do in areas where sea-water and run-off from the land merge and mix. They have extensive prop roots which reduce tidal currents and cause considerable deposition of sand and silt, thus forming a stabilizing complex along the shoreline. Mangrove environments develop a complex and socio-economically vital ecosystem that forms a well-defined ecological food-chain in which fish thrive very well. Large colonies of fish-eating birds such as herons, egrets and cormorants are found in mangrove ecosystems.

Mangrove forests are a most productive and valuable biomass. They have for many centuries supplied poles for the construction of "Swahili" houses and for the roofing of substantial dwellings in Lamu, Pate, Mamburi and Mombasa. It is estimated, for example, that about 60 per cent of Mombasa's population live in dwellings constructed according to this tradition, which is likely to live on for a long time. Mangroves also provide timber, firewood and charcoal for boat building.

The socio-economic uses of the mangroves are threatening their very existence. The export of mangrove poles to the Middle-East, where they are in high demand, makes their future uncertain. The Government has recently banned such exportation but there is evidence to indicate that a substantial illicit mangrove export trade is still thriving. There is a need to ensure that this vital ecosystem is harvested on a sustained yield basis as the destruction of the forest would not only diminish the mangroves as a resource but would also jeopardize important fish habitats.

Pollution from oil and oil-based products is also a serious threat to the mangrove ecosystems, and this needs to be controlled.

It is estimated (by the Forest Department) that a total of approximately 64,990 ha of mangrove exists along the coast, the bulk of which is in Lamu (46,184 ha), with substantially lesser areas in Kwale (12,462 ha), Mombasa and Kilifi (6,344 ha). The establishment of the current state and evolution of the mangrove forests is another important objective of the coastal zone management project.

#### COASTAL AND INLAND HYDROPOWER AND WATER WORKS

The Tana and Athi drainage systems are the major such systems that influence the coastal region. They cover catchment areas of 132,000 and 70,000 km<sup>2</sup> respectively, representing 35.7 per cent (23.7 and 12.0 per cent) of the total land area of Kenya. They carry approximately 40 per cent of the total (fresh) surface water resources of the nation and have estimated run-offs of 7 and 3 per cent respectively.

The Athi basin is relatively undeveloped at present although a number of irrigation projects are planned. The Tana basin is, however, well developed in terms of both irrigation and hydropower and, in fact, supplies practically all the hydro-electric power used in Kenya today. Schematic diagrams of development projects and proposals are given below (figures I and II).

The following development statistics for the Tana Basin underscore the importance and vastness of the Tana development system, at present the best developed of all the lake and river basins in the country (the others include the Lake Basin, the Kerio Valley and the Ewaso Nyiro basin covering 8.4 per cent, 21.8 per cent and 35.1 per cent respectively of the total land area of Kenya).

Development statistics	Masinga	Kaburu	Gitaru	Kindaruma
Length (km)	46.0	11.0	7.0	4.8
Maximum depth (m)	52.0	53.0	24.0	24.0
Area (km <sup>2</sup> )	120.0	15.0	3.1	2.4
Total capacity (m <sup>3</sup> )	1,560x10 <sup>6</sup>	150x10 <sup>6</sup>	20x10 <sup>6</sup>	16x10 <sup>6</sup>
Useful capacity (m <sup>3</sup> )	1,440x10 <sup>6</sup>	123x10 <sup>6</sup>	12.5x10 <sup>6</sup>	7.5x10 <sup>6</sup>

The irrigation schemes along the Tana basin are classified under three areas:

- Upper Tana carrying the Mwea, Kibirigwe, Mitunguu, Ishiara, Thanantu and Rubingazi irrigation schemes;
- Lower Tana with Bura West and other minor irrigation schemes;
- Food plains between Hala and the Indian Ocean with irrigation schemes in the level lands, the basin lands and the mixed alluvial, colluvial and marine sediments of Lamu district.

The Mwea and Bura West Irrigation schemes are by far the most important covering land masses of 56,000 ha and 6,700 ha respectively.

The construction of development projects along the Tana and Athi rivers gives rise to a series of consequences and effects on the downstream environment including the following:

- floods are not as heavy during the rainy season, whereas during the dry season the river flow is increased. This, in general, is beneficial to the downstream environment. However, the effect of this phenomenon in the river flood plains needs to be researched since the ecology of the flood plains is determined largely by the size and frequency of the floods;
- variation in water quality is decreased due to differences in flows between dry weather and flood seasons;
- the amount of silt carried and finally deposited by the rivers on the deltaic areas is reduced. It, therefore, becomes necessary to use artificial fertilizers in those deltaic regions where the silt is typically used for crop production;
- human settlements are bound to spring up in areas that were previously unsuitable because of flooding but which have become relatively safe due to the construction of reservoirs. Consequently, this triggers a major impact on the riverine vegetation and wildlife habitat in these areas;
- the amount of nutrients which would normally flow downstream is reduced. This results in loss of agricultural fertility and fisheries in the deltaic regions. In the case of the Athi river, for example, this means that the national marine park at Malindi would be seriously affected;
- generation of hydro-electric power from the reservoirs leads to an increase in industrialization, a positive environmental factor but one which is associated with a rise in effluents;
- the replacement of a flowing river with non-flowing but seasonally fluctuating water alters the environment of the intermediate hosts and carriers of water-borne diseases. If proper measures are not taken, an increase in such diseases as malaria, schistomiasis, bilharzia and typhoid is anticipated;
- where large-scale irrigation schemes are not properly managed the ground water table may rise. This tends to turn previously suitable grazing areas into saline or alkaline barren land.

#### SECTORAL WAGE EMPLOYMENT AND EARNINGS

During the year 1980 total labour earnings in the coastal region by district were as follows,

Mombasa	-	KSh. 73,866,600
Kilifi	-	KSh. 5,296,900
Kwale	-	KSh. 5,601,000
Lamu	-	KSh. 1,233,500
Tana River	-	KSh. 1,369,600
Taita Taveta	-	KSh. 4,017,800

which totals KSh. 91,385,400. Except for Nairobi, this was the highest level of earnings in the country for any province, representing nearly 15 per cent of the

country's total KSh. 664,120,600. This trend has persisted and is likely to continue to persist into the future.

These earnings were realized by a total of nearly 140,000 employees of whom 99,000 worked in the major towns of Mombasa, Malindi and Voi. Of these, 94,800 were employed in Mombasa alone. These figures are to be compared with a national wage employment of some 1 million persons, about half of whom work in the major urban areas of the country (towns that have more than 1,000 people in wage employment since 1982). Nairobi alone accounts for about 274,000 such employees.

Of the total coastal town wage employment, 27.5 per cent are engaged in the community social and personnel services sector, 25 per cent in the transport and communications sector, 20 per cent in manufacturing, 12.0 per cent in the wholesale, retail, hotel and restaurants trade sector, 9 per cent in the building industry, 7.3 per cent in the finance, insurance, real estate and business services sector and 4.7 per cent in the construction centre. The rest are distributed among agriculture, services (e.g. electricity and water) and the mining and quarrying sectors, each taking up less than 2 per cent of the total town wage employment. The table below indicates the total earnings by industry and by the three major towns of the province for 1980.

Country total (major towns)	Industry	Mombasa	Malindi	Voi	KSh '000 total (major towns)
55,492.2 (5)	Transport & communications	23,825.3	231.0	47.53	24,103.8
91,226.1 (2)	Manufacturing	16,946.3	15.8	12.5	16,974.6
129,018.0 (1)	Community, social & personal services	13,161.4	1,091.8	139.2	14,392.4
61,802.5 (3)	Wholesale & retail trade, restaurants & hotels	8,639.7	342.1	151.6	9,133.4
58,447.3 (4)	Finance, insurance, real estate & business services	5,374.9	147.9	24.0	5,546.8
31,693.8 (6)	Construction	3,741.7	8.1	30.1	3,779.9
	Electricity & water	1,216.6	100.9	10.1	1,327.6
10,515.1 (7)	Agriculture & forestry	738.0	113.5	1.1	832.6
500.7 (8)	Mining & quarrying	222.7	-	-	222.7
445,324.8	Total by town(s)	73,866.6	2,051.1	416.1	76,333.8

NB: The figures in brackets indicate country rankings in descending order of magnitude.

From the above statistics the following inferences can be drawn:

- Mombasa town is the most important wage-employer in the province (second only to Nairobi in the country);
- the transport sector is the most important in the coastal region, mainly because of large transport employers, including Mombasa Port, Kenya Railways and Kenya Airways, and also road hauliers, due to Mombasa's importance in the main;
- compared to Mombasa all other towns are relatively insignificant, pointing to over-centralization of development in Mombasa, a situation that needs redress;
- manufacturing, community, social and personal services and others (in the order given in the table) derive their importance from Mombasa's key role;
- coastal agriculture is, for the most part, of a subsistence nature and the majority of transactions in this sector do not enter into the wage economy;
- mining and quarrying activities are relatively insignificant and take place mostly in Mombasa;
- the general socio-economic characteristics of the urban areas of the region are at variance with those of other urban areas in the country as a whole and are only roughly representative of the national picture in the last three sectors of the table (as evidenced by the fact that regional figures are given in descending order of magnitude and these do not tally with country rankings).
- the most significant development-oriented environmental problems are likely to emerge from the transport and manufacturing sector in the main. It is well known that the most serious environmental problems in the coastal region are those having to do with under-development resulting from the difficult socio-economic conditions in which the region, as well as the country, finds itself.

#### A NOTE ON IMPLEMENTATION

This is one of the many studies that have been carried out on various socio-economic aspects of the coastal region of Kenya. A Coast Province Regional Physical Development Plan was developed as far back as 1971, by the then Town Planning Department of the Ministry of Lands and Settlements. This followed closely on a Coast Province Planning Project carried out between 1968 and 1970 under the auspices of the then Ministry of Finance and Planning.

Considerable national data sources exist from which regional inferences can be drawn. Important among these sources are the Census Data, the Annual Statistical Abstract, the Five-Year Development Plan, the National Atlas of Kenya and many others. The Coast Provincial Office and the various district offices, as well as the technical sectoral government departments and ministries, prepare annual reports and Five-Year District Development Plans from which a wealth of information and data can be derived. Various consultant groups have also carried out specific sectoral and/or sub-regional studies.



The National Environment and Human Settlements Secretariat carried out a project on Environment and Development which, although national in scope, contains fairly specific information on marine and coastal resources. The secretariat is now carrying out a Coastal Zone Management Project to prepare Kenya's input into the East African Regional Seas Programme and also to develop the environmental input into the new district-based national development strategy. The Permanent Presidential Commission on Soil Conservation and Reafforestation has carried out a thorough survey of coastal soil erosion and deforestation.

These and many other studies have accumulated and will continue to accumulate more information on the total environmental picture of the region. What is required now is to assimilate the various pieces and, even more importantly, to present a focus on what should or can be done to improve the socio-economic status of coastal populations and the state of the environment in this region. The coastal zone management plan, emanating from the project of the same name, might fill this gap by developing a series of meaningful activities and programmes. Such activities, projects and programme proposals may determine what can and ought to be done:

1. To improve coastal agriculture, minimize soil erosion and promote agro-based industries along the coast.
2. To further improve the status of shelter, infrastructure and services in the region.
3. To save the coral reef from siltation, dynamiting, crown of thorns starfish, oil pollution and other dangers and to promote mangrove forest growth and sustainable management.
4. To develop balanced physical growth of the coast and conserve historical sites and monuments.
5. To promote further fishery development and marketing.
6. To curb the threat of cultural aberration emanating from tourism.
7. To save the beaches from siltation with programmes covering the length of riverways from source to mouth.
8. To provide water and health services and promote recreation among the population.
9. To minimize the level of pollution from industrial and transport-based sources.
10. To promote environmental awareness.
11. To implement suggestions and recommendations contained in various other studies.

The extent to which these actions are undertaken to their logical conclusions will determine the extent to which the whole environment of the coastal region of Kenya will improve and survive.

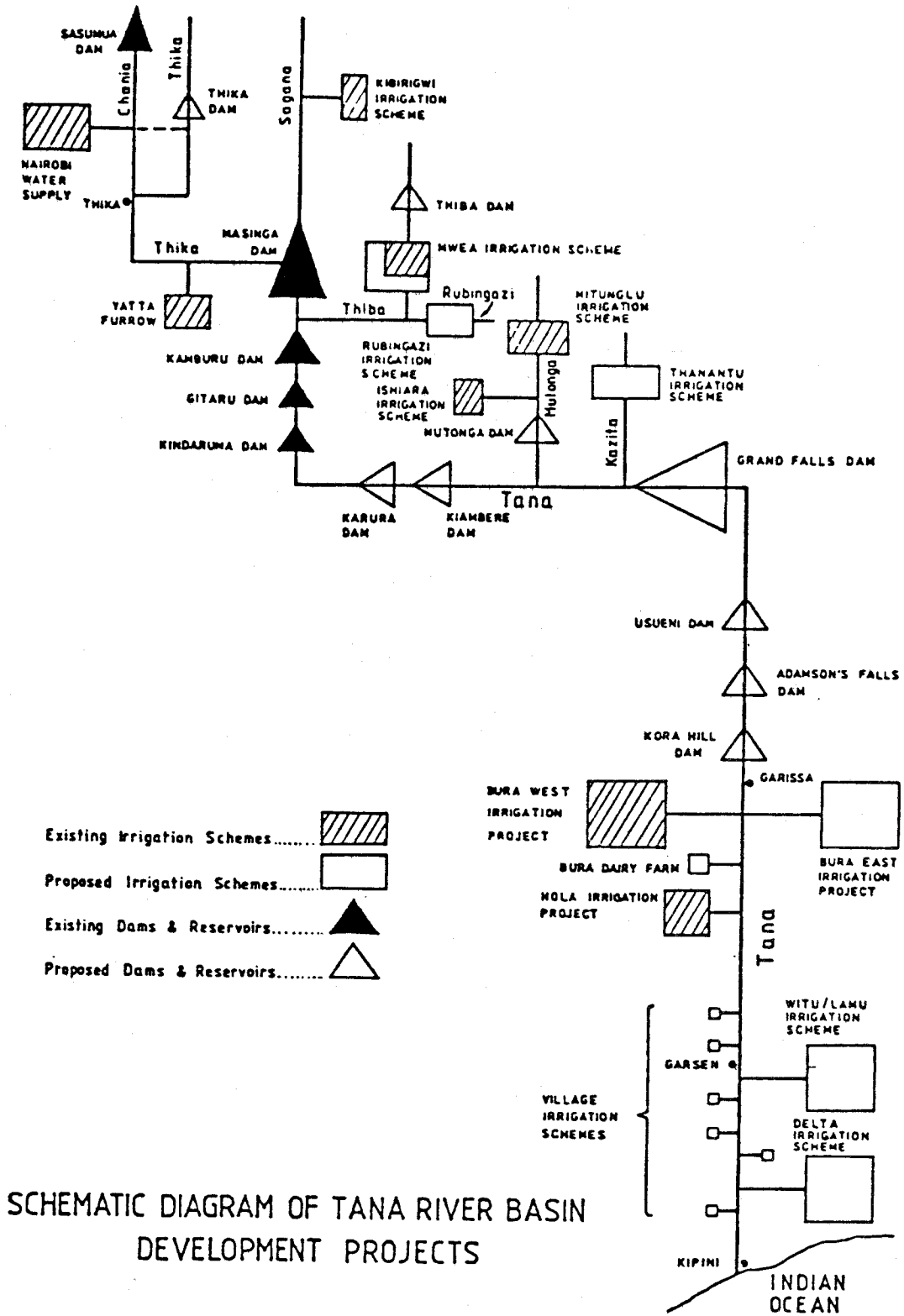
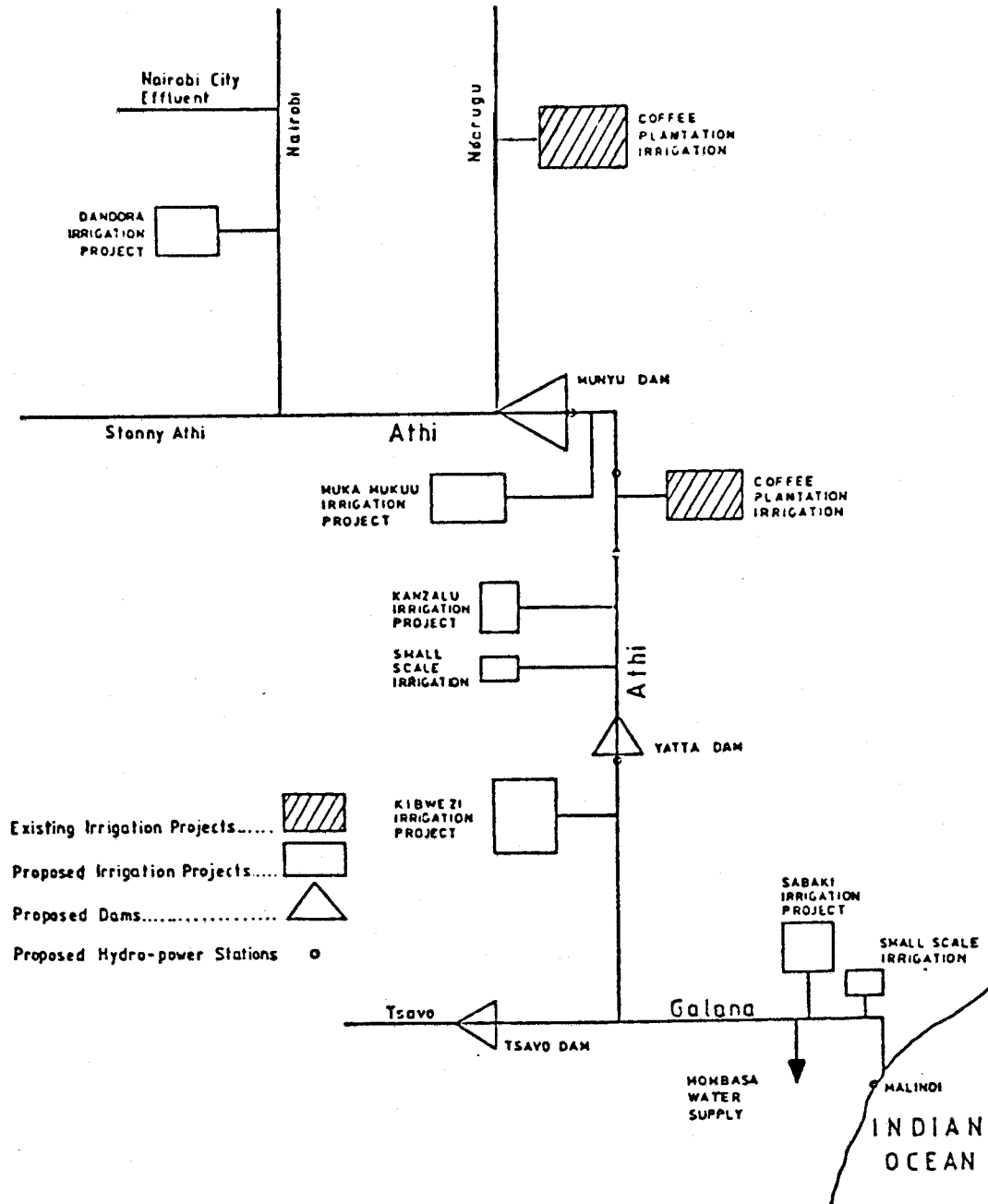

Figure 1



SCHMATIC DIAGRAM OF ATHI RIVER BASIN DEVELOPMENT PROJECTS

Figure 2

RAPPORT NATIONAL POUR MADAGASCAR : par H. D. Rabesandratana

DONNEES DE BASE

Situé entre 12° et 25°30' de latitude sud et entre 43° et 50°30' de longitude est, Madagascar se trouve en pleine zone intertropicale. Il s'étend sur 1 650 km de longueur sur 575 km de largeur maximum, et possède une superficie de 590 000 km<sup>2</sup> et 4 000 km de côtes.

Les côtes (carte no 1)

Dans l'ensemble, les côtes sont du type continental formant un littoral de type continental à cause des effets (dépôts d'alluvions donc envasement, dessalure, etc. au niveau des embouchures) occasionnés par les volumes importants d'eau douce et par la masse énorme de sédiments charriés à partir de vastes bassins hydrographiques situés dans les hautes terres. On a évalué "les apports solides du fleuve Betsiboka entre 40 et 50 millions de tonnes de matériaux par an. Au fur et à mesure que se comblent les fosses antérieurement très profondes de la baie de Bombetoka où se trouve le port de Mahajanga, la quantité de matériaux qui se dépose au large augmente. 70 pour cent des apports solides proviennent du bassin supérieur de la Betsiboka dont les sols sont particulièrement érodables du fait de leur nature géologique et de l'absence de couverture végétale" (Laboratoire Central Hydraulique de France, L.C.H.F. 1973). Ces côtes se caractérisent également par une alternance de plages sableuses, d'affleurements rocheux ou de plages de galets.

Plages de sable

Elles sont très étendues sur la côte est et sur la côte ouest. Sur la côte est, les alluvions déversées par les fleuves aux fortes ruptures de pente lors de leur entrée en plaine sont repris par les courants et les vents pour former un cordon littoral (Donque, G., 1974). Les plages de mode très battu longent, sur plus de 850 km, la côte: du nord de Fénériver-Est au nord de Tolagnaro où les éléments constitutifs sont siliceux. Dans la région sud, aux environs du fleuve Menarandra, et jusqu'au delta de Mangoky, les plages sableuses côtoient les cordons dunaires littoraux d'âge flandrien, et sont alimentées par les séries de récifs coralliens frangeants ou barrières. Cette longueur de 450 km est cependant interrompue en quelques rares endroits soit par des éboulis de falaises calcaires (Barn-Hill au nord de la baie de Saint-Augustin) soit par des affleurements, au haut de la plage, de bancs de grès marins anciens (ex: environs de Toliary). Ces plages sableuses longent le littoral occidental vers le nord jusqu'au Cap Saint-André sauf au niveau des zones d'envasement autour des embouchures des fleuves et des rivières, et réapparaissent de part et d'autre de Mahajanga (carte no 1).

La zone sableuse située surtout au sud de Morombe constitue un lieu de ponte des tortues marines Eretmochelys imbricata Linné (omnivore), Chelonia mydas L. qui vit dans la zone des Phanérogames marines des récifs coralliens, Caretta caretta L. prédateur de mollusques bivalves, Dermochelys coriacea, assez rare, de régime carnivore. Malheureusement les oeufs pondus repérés par les riverains sont ramassés en totalité, étant considérés comme une bénédiction divine, tandis que les animaux nageant dans les eaux littorales sont piégés au filet ou harponnés pour leur chair et seront vendus sur le littoral. Notons également que ces plages sableuses offrent une source appréciable de protéines par les innombrables petites bivalves qui y vivent, dans la zone intertidale : divers Donax (D. triradiata, D. madagascariensis, etc.), Mesodesma glaberrimum.

En outre, les plages de l'extrême-sud situées à proximité de l'embouchure des quatre fleuves sont riches en minéraux lourds : grenat, ilménite, monazite, etc. Une plage grenatifère importante se trouve à Lambetakamasay au nord du delta de Linta, près d'Itampolo. L'ilménite est exploitée à Tolagnaro. Onze gisements de monazite des plages vives situées entre l'embouchure de Mandrare et Vangaindrano peuvent intéresser des industries nucléaires (Battistini, R., 1964). La présence de ces minéraux lourds sur les plages du sud témoigne de l'intensité de l'érosion des chaînes anosyennes.

#### Pollution des plages par l'homme

Certaines plages sont souillées de déjections humaines: Vatomandry, Mananjary, tous les environs de Toliary (aussi bien au sud que vers le nord), et Morombe. On pense que la mer sert de "voirie" qui nettoie les déchets déposés sur la plage lors des marées montantes. Des coutumes ancestrales interdisent de mettre les excréments dans un coin (fosse) de la cour ou de la maison, mais il faut les jeter à la mer. D'ailleurs les W.C. publics sont mal utilisés, peu soignés, puis abandonnés. Souvent les agents chargés de la vidange ont été méprisés par leur famille et l'argent qu'ils gagnaient, considéré comme de l'argent "sale" et les parents n'en voulaient pas, même s'ils étaient dans le besoin. L'éducation des enfants faite à l'école devient inefficace devant les "habitudes du clan". Celle des parents responsables s'avère donc également d'une urgente nécessité. En outre les animaux domestiques comme les porcs, les volailles, participent en mineure partie au nettoyage de la côte car ils se nourrissent de déjections non emportées par la mer.

A la pollution aérienne s'ajoute donc la pollution microbienne de la plage:

- contamination par les bactéries de tous les maillons de la chaîne alimentaire aussi bien pélagique que benthique;
- infestation directe des animaux consommateurs d'excréta frais par les bactéries et par les vers (*Ascaris*, *Taenia*, etc.,) à marée basse.

Cette situation se traduit par la recrudescence des maladies infectieuses (fièvre typhoïde) et des maladies intestinales d'origine helminthique.

#### Plages de galets

Rares, elles se localisent, soit au pied des escarpements rocheux: Cap Sainte-Marie, plateau calcaire de Barn-Hill au Nord de la baie de Saint-Augustin, soit au niveau des affleurements (ceux du socle basaltique à Lavanono dans l'extrême-sud).

#### Côtes rocheuses (carte no 1)

Elles sont de deux sortes:

i) Les côtes rocheuses élevées de plus de 150m comme les cas:

- des deux horsts cristallins des plateaux de Makira et de Masoala qui enserrant entre leurs pentes raides disséquées par l'érosion, le graben envahi par la mer de la baie d'Antongil (Donque, G., 1974);
- des escarpements calcaires du Cap Sainte-Marie dans le sud;
- de la falaise éocène de Barn-Hill au Sud de Toliary.

ii) Les côtes rocheuses moyennement élevées de 50 à 150m se localisent:

- sur la face orientale du Cap Masoala sur la côte est;
- sur la côte allant de Mahajanga vers la pointe nord de Madagascar sauf au niveau des embouchures et en face de la baie d'Ambaro;
- entre le Cap Sainte-Marie et le sud-est de Tolagnaro où apparaissent des estrans rocheux.

D'ailleurs les estrans grésocalcaires de l'extrême-sud et du sud-ouest de Madagascar avec leurs petites vasques particulières étagées ou non offrent un paysage magnifique inégalable dans la région de Tolagnaro, à Faux Cap, dans la région du Cap Sainte-Marie, le long du littoral Mahafaly, en face de Barn-Hill au nord de la baie de Saint-Augustin et près de Morombe (Battistini, R., 1980).

#### Les peuplements

Tous ces divers substrats durs montrent suivant les modes d'agitation de l'eau, des biocénoses benthiques appropriées aux différents étages littoraux classiques. Les pans de falaises, les affleurements gréseux et les blocs de différentes tailles possèdent une faune variée dont l'huître Crassostrea cucullata Born à l'étage médiolittoral. Ainsi des gisements intéressants existent à Lavanono, à Andavadoaka près de Morombe, à Boanamary et à Katsepy (Mahajanga), à Ampepamena (Ambanja), à Nosy Be, à Ambodivahibe (côte nord-est d'Antseranana), à Ambodifototra (île Sainte-Marie). La partie frontale des estrans grésocalcaires de l'extrême-sud de mode très battu forme des bancs naturels immenses à très forte densité, de cette même espèce, à Ankatravitra, à Fenambosa - Bevoalavo, bancs atteignant plusieurs centaines de mètres de long, voire plusieurs kilomètres (Fenambosa) sur plusieurs dizaines de mètres de large (Rabesandratana, H.D., 1974). Crassostrea cucullata coexiste avec une moule comestible Mytilus perna (ou M. elongatus) située à un niveau légèrement plus bas (étage infralittoral supérieur) à Fenambosa, à Androka, Evatraha (nord de Tolagnaro). Les formations en petites vasques des estrans sont très riches en algues de toutes sortes dont les épaves forment une petite montagne d'un ou deux mètres de haut jonchant la plage (ex. de Lavanono). Plus profondément, vivent des éponges de différentes espèces dont les éponges de toilette (Lavanono).

#### Action de l'homme sur ces peuplements

Remarquons que:

- dans le sud, les pêcheurs arrachent les huîtres (Crassostrea cucullata) qui forment des bourrelets hauts d'une trentaine de centimètres, par blocs entiers de quelques décimètres cubes, à l'aide d'une barre à mine. Ils choisissent les belles tailles et jettent le reste (ex: à Ankatravitra, près de Faux Cap). C'est de cette façon que ces magnifiques bancs naturels risquent de disparaître;
- dans la région de Mahajanga, de la vase latéritique (rouge) du fleuve Betsiboka recouvre les affleurements rocheux de Boanamary et de Katsepy où cette même espèce d'huître forme des bancs naturels assez importants. A ces endroits, par une sorte de chlorose, la couleur de la coquille devient blanche ce qui lui a fait donner le nom d'Ostrea vitrefacta. Actuellement une bonne partie de ces bancs est morte par envasement et les coquilles sont exploitées pour la fabrication des provendes.

Les récifs coralliens

Localisation (carte no 1)

Les madréporaires, principaux constituants des récifs coralliens exigent pour leur développement des conditions écologiques bien déterminées: température supérieure à 18°C, salinité élevée d'au moins 35 ‰, forte luminosité donc transparence des eaux et forte agitation également. Un substrat dur leur est nécessaire pour leur installation, donc un fond situé dans la zone euphotique. Sur la côte ouest, des récifs frangeants alternant souvent avec des récifs barrières longent la côte sud-ouest depuis les environs de l'embouchure de la Linta jusqu'à Morombe. Le Grand Récif de Tuléar est le mieux connu grâce à la présence de la Station Marine. Des îlots et des haut fonds coralliens localisés entre le nord du delta de Mangoky et le nord du Cap Saint-André se sont installés assez loin de la côte. Enfin quelques-uns florissent autour de Nosy Be et entre Analalava et la pointe nord de Madagascar où l'effet des cours d'eau est moindre. Sur la côte Est, où le plateau continental descend rapidement, ces récifs deviennent rares et n'existent que, soit sur le rebord oriental des affleurements rocheux (Cap Masoala, et entre Pointe Larrée et Mananara-Nord, à Mahavelona, à Toamasina), soit autour de petites îles: île Sainte-Marie, Nosy Vorona à l'Est de Fénériver-Est. Des formations coralliennes de moindre importance existent dans la région du Nord-Est sous forme d'îlots.

Etendue des récifs coralliens

Si les récifs coralliens de la côte est sont peu importants, ceux de la côte ouest peuvent être figurés et cités du sud vers le nord dans le tableau suivant:

LOCALISATION	Longueur en km	Largeur max en km	Références
Grand Récif corallien d'Androka (Ambohibola au Cap Andriamano)	20		Battistini
Récif frangeant d'Itampolo	10		"
Récif de Lanivato à Besamata	55		"
Récif de Besamata à la baie de Saint-Augustin	45	3 (au nord de Behekoka)	"
Baie de Saint-Augustin au delta du Mangoky	300		
Récifs coralliens de Belo-sur-mer:			Salomon, J.N.
- Andriamitoraka	5	1,5	
- Mahalolo	1,25	0,6	"
- Angorahoka	1	1	"
- Andriangory	2,2	1,6	"
- Tania	1,5	0,4	"
- Groupe Bawden	1,3	0,5	"
Récif barrière immergé de la bordure externe du plateau de la côte nord-ouest	600		Crosnier, A.
T O T A L	1 042,25	0,4 à 3	

Bref, ces formations coralliennes s'étendent sur plus de 1 042 km de long et leur largeur peut varier de 0,4 km à 3 km.

## Les peuplements

Par la diversité des biotopes, la faune et la flore de ces écosystèmes présentent une très grande richesse au point de vue nombre d'espèces différentes présentes. Une multitude d'animaux grouillent dans ces viviers naturels. Sont bien connus les innombrables poissons de coraux aux couleurs vives et variées qui foisonnent parmi les madréporaires richement représentés (plus de 100 espèces), les crustacés décapodes dont divers crabes et les langoustes, les mollusques gastéropodes dont certains sont comestibles (Murex, Turbo, Fasciolaria, etc.) mais la plupart sont très recherchés par les collectionneurs comme les genres Conus avec 80 espèces, Cypraea (42 espèces), Terebra (+ de 40 espèces), Oliva, Harpa, etc. Le casque rouge Cypraeacassis rufa est exporté en Italie (Naples) pour la fabrication des camées; certaines espèces d'échinodermes en particulier d'holothuries ou concombres de mer (Holothuria scabra, Thelenota ananas, etc.) sont exportées au Japon ou en Chine, tandis que les oursins comestibles (Tripneustes gratilla) sont ramassés pour la consommation locale.

Ces populations de poissons, langoustes, coquillages, d'algues marines, etc. constituent de véritables réserves qui appartiennent au patrimoine commun de l'humanité. Leur extrême beauté en fait un capital scientifique et touristique inappréciable qu'il convient de préserver sous forme de réserves naturelles, comme Salomon, J.N. (1980) l'avait proposé pour les eaux de Belo-sur-mer. Le projet de mise en parc naturel du Grand Récif de Toliary n'a malheureusement pas encore été retenu par les autorités. Cet ensemble admirable a été l'objet de nombreuses études aussi bien nationales qu'internationales qu'il faudrait intensifier.

### Action destructrice de l'homme

Outre leur rôle dans l'alimentation des poissons de coraux des genres Chaetodon, Lutjanus, Monodactylus, Rhabdosargus, etc. par leurs innombrables et minuscules polypes, les madréporaires massifs constituent des supports solides pour la fixation des larves de divers animaux benthiques sessiles (cnidaires, crustacés cirripèdes, mollusques, etc.). L'extraction de ces animaux coloniaux (ex: Porites somaliensis) même morts dans la zone de microatolls des récifs coralliens, en guise de pierres de construction (dalles, murs, fosses septiques, etc.) réduit donc la chance de fixation de ces larves d'invertébrés ainsi que la nourriture des poissons. Mais des cas ont été constatés à Toamasina (Bain des Dames) et sur le Grand Récif de Toliary par boutre entière.

### Les Mangroves

Elles occupent une superficie totale de 3 200 km<sup>2</sup>. Ces formations de palétuviers se développent sur les vases côtières où leurs exigences écologiques sont remplies: position géographique tropicale ou intertropicale, plateforme littorale basse, dessalure, forte amplitude des marées (3 m), mode d'agitation de l'eau faible ou nulle et forte sédimentation. En effet, les sédiments charriés par les eaux continentales fluviales ou non sous l'effet des sels de l'eau de mer se déposent par phénomène de floculation sous forme de banquettes de vases fines soit au niveau de l'embouchure des fleuves et des rivières, soit en bordure des côtes. On distingue alors les mangroves d'estuaires et les mangroves littorales.

Le climax est formé par cinq ou six espèces d'arbres palétuviers dont les trois premières sont plus représentées que les autres. Ces plantes peuvent porter des noms vernaculaires différents suivant les côtes Ouest ou Est:

- Avicennia marina ou mosotro, afafy (côte Ouest) ou honko est l'espèce pionnière du groupe, plus résistante aux conditions défavorables; en cas de forte



sédimentation elle est la seule à subsister en terre ferme (ex : présence de nombreux pieds à plusieurs kilomètres du rivage, sur la route d'Ambodivahibe dans la région d'Antseranana);

- Sonneratia alba ou farafaka (côte Ouest), vahombavy (côte Est);
- Rhizophora mucronata appelé honkolahy, anabovahatra ou honko en sakalava (côte Ouest) et voandrano en betsimisaraka (côte Est);
- Ceriops boiviniana ou honkovavy, farafaka;
- Bruquiera gymnorhiza ou tangampoly, tsitolona;
- Lumnitzera sp.

#### Localisation

Sur la côte ouest, les mangroves d'estuaires se localisent à l'embouchure de Fiherenana, au delta de Mangoky, dans la région de Morondava, de Belo-sur-Tsiribihina, de Maintirano jusqu'à Analalava, et dans la région d'Ambanja - Ambilobe (carte no 2 et annexe I). Des exemples de mangroves littorales peuvent être cités dans la région de Toliary au nord de Sarodrano, à Ankilibe, Ankiabe, en face de Toliary-ville, Songoritelo, etc. où il y a des résurgences d'eau douce sur la plage. Sur la côte est, des mangroves moins importantes se rencontrent dans la région d'Antseranana en allant vers la plage de Ramena et à Ambodivahibe, à Vohimarina, à Manompana en face de l'île Sainte-Marie et à Lokaro et Sainte-Luce dans la région de Tolagnaro.

#### Les peuplements

Les troncs et les racines aériennes de palétuviers constituent de véritables substrats solides pour l'installation des organismes benthiques. Bien que très réduits par rapport à ceux des substrats rocheux, de même mode (calme) ces peuplements présentent des espèces caractéristiques aux différents étages: Littorina scabra (petit gastéropode) au supralittoral, le crustacé cirrhipède Chthamalus antennatus au médiolittoral supérieur, l'huître Crassostrea cucullata au médiolittoral inférieur. Les banquettes de vases fines fixées par les algues vertes filamenteuses des genres Lyngbia et Vaucheria hébergent de nombreux crabes dont les genres Uca (petit crabe "violoniste") et Scylla espèce serrata qui est encore insuffisamment exploité bien qu'il présenterait un intérêt commercial. Les vers annélides, moins importants du point de vue économique, participent aux maillons de la chaîne alimentaire et aèrent par leurs galeries ce biotope de boue noire asphyxiante. Dans les chenaux de drainage où coulent des eaux saumâtres vivent de petits poissons amphibiens, les périophtalmes, des stades juvéniles d'autres poissons ainsi que ceux des crustacés décapodes comme les crevettes et les crabes. D'ailleurs ces faunes ichthyologique, carcinologique et malacologique de mangroves mériteraient une étude sérieuse aussi bien scientifique (écologique, biologique, etc.) qu'économique en vue de l'aquaculture appliquée dans ce secteur.

#### Effets destructeurs de l'homme

Si le défrichement et les brûlis de la couverture végétale dans les hautes terres entraînent le transport vers la mer des sols arables (40-50 millions de tonnes/an), cette action destructrice de l'homme se poursuit encore dans les mangroves qui les retiennent. Les troncs de palétuviers sont coupés à Ankilibe, presque anéantis dans "l'anse de Sarodrano" dans la région de Toliary, utilisés

comme bois de chauffage ou de clôtures. Les bois de construction longs de 3 à 4m ainsi que les bois de chauffage vendus sur le quai de Mahajanga sont constitués de "honko" et de "honkovavy" c'est-à-dire de Rhizophora et de Cerriops en provenance de Marosakoa et de Marerano. L'écorce de Rhizophora mucronata est utilisée pour teindre les tapis mohair dans le sud du pays.

### Lagunes côtières

#### Localisation et étendue (carte no 2)

La côte ouest de Madagascar ne comporte que l'importante lagune de Loza occupant 15 600 ha. Sur tout le long de la côte orientale de Tolagnaro à Fénériver-Est, on en rencontre fréquemment de plus ou moins importantes, séparées de la mer par des formations dunaires encore souvent couvertes par une belle forêt littorale. Indiquées sur la carte no 2, elles comprennent d'après KIENER (1963):

I Loza:	45 600 ha
II Pangalanes-Est:	18 000 ha
III Anony (Tolagnaro):	2 262 ha
IV Ampahana - Antalaha:	2 175 ha
V Masianaka - Vangaindrano:	1 329 ha
VI Région de Tolagnaro:	
VII Tampolo - Fénériver:	155 ha
VIII Petits Pangalanes - Soanierana - Ivongo	

Les surfaces indiquées sont évaluées à 23 921 ha.

#### Rôles de ces lagunes côtières

##### (a) Pêche

Kiener (1963) a signalé que les lagunes côtières de la côte Est entre autres, Ampahana, Tampolo-Fénériver, les Petits Pangalanes-Est, Masianaka et sur-tout Anony, étaient très poissonneuses et largement visitées par des espèces euryhalines comme des Angera (Pomadasy operculara), des gueules pavées (Chrysophris sarba), des carangues, etc. Il a remarqué que la lagune d'Anony présentait un intérêt exceptionnel au point de vue adaptation de certaines espèces euryhalines dans les eaux intérieures, car, à ce moment-là, la dune artificielle n'était pas encore définitivement fermée. Lors de chaque ouverture de la dune, sous la pression des hautes eaux, les quantités de poissons qui pénétraient dans les eaux saumâtres étaient très importantes et elles y étaient emprisonnées par reformation rapide de la dune. La pêche dans le lac ravitaillait essentiellement le marché d'Amboasary ainsi que la main-d'oeuvre des nombreuses concessions de sisal de la région du Bas-Mandrare.

Cependant, G. Lasserre (1979) signale la diminution des rendements d'exploitation des poissons dans les Pangalanes-Est: 30 kg/ha/an en 1966, 6 à 8kg/ha/an en 1978, 1 - 2 kg/ha/an prévu en 1990. Il donne la cause de cette baisse: les communications avec la mer, étant devenues rares, il y a appauvrissement du milieu en plancton et en substances nutritives, c'est-à-dire que la base de la pyramide alimentaire est devenue étroite. Le cas du Lac Anony qu'il rapporte est spectaculaire. Depuis que ce lac ne communique plus avec la mer (1971), à cause des formations dunaires, le rendement de la pêche a tellement diminué que des 300 à 400 pêcheurs appartenant à neuf villages différents (dont trois de pêche exclusive), il ne restait plus que dix en 1978. Des villages entiers ont abandonné toute activité

### Variation annuelle de la température minimale moyenne

La température minimale moyenne atteint sa plus faible valeur en juillet - août pour l'ensemble de Madagascar (17°5C Toamasina; 9°2C Antananarivo; 18°7C Mahajanga; 18°3C Maintirano; 13°4C Morondava; 13°9C Toliary; 12°7C Tsihombe); toutefois, elle stationne ou baisse encore un peu en août dans le nord (20°9C Antseranana).

### Variation annuelle de la température maximale moyenne

#### (a) Côte Est

Antseranana et extrême-Nord: La courbe de variation a deux maxima de valeur sensiblement égale: le premier en avril (32°5C), le second en décembre (32°3C). Ils sont séparés par deux minima: le premier en janvier (31°2C), le second en août (29°4C).

Autres stations de la côte Est: La courbe a un maximum de janvier à février (compris entre 28°5C et 30°9C suivant les stations) et un minimum en juillet-août (entre 23°6C et 26°7C).

#### (b) Plateaux

La courbe présente un maximum en novembre (27°5C) Antananarivo; (27°C) Fianarantsoa; (23°8C) Betroka.

#### (c) Côte Ouest

D'Antseranana à Maintirano la courbe a deux maxima: l'un en octobre, novembre ou décembre (32°7C) Mahajanga; (31°5C) Maintirano, l'autre en mars ou avril (32°9C) Mahajanga; (31°2C) Maintirano. Ils sont séparés par deux minima: l'un très peu marqué en janvier (31°3C) Mahajanga; (31°0C) Maintirano, l'autre plus net en juillet (30°5C) Mahajanga; (26°8C) Maintirano.

De Morondava à Toliary la courbe a un maximum de janvier à mars (31°8C) Morondava; (32°5C) Toliary et un minimum en juin-juillet (27°5C) Morondava; (26°6C) Toliary.

### Le vent

#### (a) L'alizé

Le vent principal de Madagascar est l'alizé de Sud-Est provenant de l'anti-cyclone semi-permanent de l'Océan Indien et dont la régularité est remarquable de juin à août. Les courants d'alizé sont très humides et apportent des précipitations abondantes sur la côte et le versant Est. L'épaisseur de l'alizé varie entre 2 000 et 4 000 mètres. Les basses couches de l'alizé sont fortement déviées par le relief vers le Nord, de Toamasina à Antalaha et vers le Sud, de Mananjary à Tolagnaro. Sa vitesse a une variation diurne bien marquée, c'est ainsi qu'à Antseranana, elle varie en août de 64 km/h (14 heures) à 26 km/h (5 heures).

#### (b) Les courants d'Ouest

L'alizé est surmonté de courants d'Ouest subsidents et secs. Lors des passages au Sud de Madagascar des thalwegs polaires, l'alizé disparaît parfois sur une grande partie de l'île et laisse la place aux courants d'Ouest. En hiver, lorsqu'ils arrivent au sol, ces courants donnent sur les régions qu'ils intéressent un temps généralement clair ou peu nuageux avec des brouillards matinaux sur les plateaux. En

été, ces courants d'Ouest s'humidifient par la base sur le Canal de Mozambique et, en atteignant les plateaux, favorisent le développement des orages sur les régions où ils sont en convergence avec le régime de Sud-Est.

(c) Vent de Nord-Ouest

En été, l'anticyclone d'Arabie développe parfois une dorsale sur le Nord du Canal de Mozambique; il s'établit alors par intermittences sur les régions Nord-Ouest et le centre Ouest, ainsi que sur la partie occidentale des plateaux des courants de Nord-Ouest faibles à modérés (appelés mousson par certains auteurs). D'origine équatoriale, ce vent très instable favorise sur les régions qui l'intéressent le développement de foyers orageux. A la suite d'une évolution cyclonique, ce vent se renforce et s'accompagne de fortes pluies. La limite entre les vents de Nord-Ouest et ceux du Sud-Est est appelée zone de convergence intertropicale. C'est dans cette zone que se forment les perturbations cycloniques.

Brises de terre et brises de mer

Ces brises sont observées à un degré plus ou moins net sur les côtes. Elles donnent localement aux vents généraux une composante vers la terre ou vers la mer. Elles sont particulièrement nettes sur la côte Ouest, abritée de l'alizé et dont l'hinterland présente une forte variation diurne de la température.

Les pluies

Les caractères essentiels du régime des pluies sont les suivants:

- la hauteur annuelle varie de 34 cm sur la côte Sud-Ouest à 370 cm dans la baie d'Antongil. A noter le relevé annuel moyen de la station forestière des Roussettes (Montagne d'Ambre du massif du Tsaratanana) qui atteint 380 cm;
- le nombre moyen de jours de pluie est compris entre 30 et 250 par an.

Sur la côte et le versant Est, 30 à 50 pour cent du total annuel tombent pendant le semestre chaud. Pour ces régions, il n'existe pas de saison sèche bien définie, mais seulement une diminution des précipitations en septembre-octobre.

Caractéristiques des courants

Dans l'hémisphère Sud, le courant Sud-équatorial, situé à une latitude d'environ 12°S est le principal courant circulant toute l'année d'Est en Ouest. Une partie de ce courant bifurque au Nord-Est de Madagascar pour former le courant-Est malgache. Après la pointe Nord de Madagascar, ce courant se divise en deux branches: l'une se déplace vers le Nord et donne le courant côtier Est-africain, l'autre traverse le Canal de Mozambique en direction du Sud pour former le courant de Mozambique. Au Sud de Madagascar, le courant-Est malgache et le courant de Mozambique se rejoignent à une latitude d'environ 26°S pour former le courant des Aiguilles.

D'après Soetre et Silva (1979), le courant orienté vers le Nord en sens contraire du courant de Mozambique (courant côtier Est-africain), plus rapide, engendre des courants circulants locaux dans le Canal de Mozambique. L'effet de ces courants marins, au point de vue écologique se traduit par les affinités entre la faune et la flore de la région: on rencontre les mêmes espèces de mangroves, de tortues de mer, de crevettes et de poissons de mer. Les coraux et les poissons coralliens se ressemblent dans tout l'Océan Indien, jusque dans le Pacifique.

## DEVELOPPEMENT DES ZONES URBAINES ET RURALES

### Les principales villes et les principaux établissements humains du littoral

La carte no 5 montre les anciennes sous-préfectures touchant le littoral lors du recensement général de 1975 effectué par l'Institut National de la Statistique et de la Recherche Economique, INSRE, avec leur densité respective de population ainsi que les principaux centres urbains. Notons qu'après la restructuration administrative de 1975, chaque province ou Faritany subdivisée anciennement en préfectures et en sous-préfectures S/P ne possède plus actuellement que des Fivondronam-pokontany (FVP), correspondant aux sous-préfectures. Dans la nouvelle structure, la préfecture n'a donc plus son équivalent. Quelquefois, la sous-préfecture s'est scindée en deux Fivondronam-pokontany I et II (urbain et rural), ou a changé de limites. Dans l'ancienne structure, la Commune est la plus grande subdivision d'une sous-préfecture tandis que le Firaisam-pokontany est celle de l'actuel Fivondronam-pokontany. Le village est devenu le Fokontany, placé sous la tutelle d'un Comité exécutif présidé par le Président du Fokontany. Le Fokontany est l'unité géographique de base de l'actuelle subdivision administrative. Les renseignements concernant les principales villes et les principaux établissements humains du littoral se résument dans le tableau suivant:

Noms des villes	Caractéristiques (cf tableau no 4 annexe II)
Faritany de Toamasina:	Chef-lieu de Faritany (Province)
Toamasina I	3e ville de Madagascar après Antananarivo (capitale) et Fianarantsoa - ville touristique - 1er port commercial - ville industrielle et commerciale avec une grande raffinerie SOLIMA, plusieurs industries de transformation, des agro-industries: une huilerie, deux industries chimiques: SOMALAVAL, ZEREN; cette dernière en voie de finition n'est pas encore fonctionnelle.
Maroantsetra	Ces neuf centres urbains tertiaires sont surtout à
Mananara-Nord	vocation agricole, zones de collecte des produits (vanille
Soanierana-Ivongo	café, girofle, canne à sucre, poivre, banane, cannelle,
Fenerive-Est	etc.). Ambodifotora et l'île Sainte-Marie (Nosy Boraha)
Ambodifototra (île Sainte-Marie)	ont un intérêt touristique, tandis que Brickaville, un
Vavatenina	intérêt industriel avec sa sucrerie. En général, zones
Vatomandry	touristiques par leur végétation (forêt primaire).
Brickaville	
Mahanoro	
Faritany de Mahajanga:	Chef-lieu de Faritany
Mahajanga I	4e ville, 2e port commercial long-courrier secondaire - ville industrielle avec une grande usine textile SOTEMA, une de filature et tissage de paka FITIM, une d'égrenage de coton HASYMA, une cimenterie; des agro-industries: deux huileries - savonneries (SIB, SEIM), deux usines crevetières (étêtage congélation, conditionnement, expédition) SOMAPECHE et SOPEBO; un abattoir frigorifique national AFN-M; une usine sucrière à Namakia (SIRAMA - Namakia).

Marovoay	Petite ville agricole (riz).
Analalava	Port de cabotage secondaire.
Maintirano	Port de cabotage secondaire.
Soalala	
Besalampy	

Faritany de Toliary: Chef-lieu de Faritany

Toliary I	5e ville urbaine, port long-courrier secondaire - ville touristique par son fourré aux espèces endémiques et par ses récifs coralliens - ville industrielle avec une usine textile SUMATEX, des agro-industries: une brasserie STAR, une huilerie - savonnerie SNHU, une d'égrenage de coton HASYMA, deux usines de transformation VIFOISY, TOLY.
Tolagnaro	Ville touristique par la beauté de son paysage (contraste montagne-mer, végétation luxuriante) une industrie textile de sisal SIFOR - port principal de cabotage.
Morondava	Port principal de cabotage - ville agricole (riz, canne à sucre, coton, agrumes) - ville industrielle avec une huilerie - savonnerie SICA, une sucrerie SIRANALA en voie de fonctionnement (octobre 1983), une société d'exploitation industrielle et agricole, SECIAM.
Morombe	Port de cabotage secondaire - vocation agricole (pois de Cap, coton, riz et pêche).

Faritany d'Antseranana: Chef-lieu de Faritany

Antseranana	Port long-courrier secondaire, 6e ville urbaine, ville industrielle avec un grand chantier naval SECREN, des agro-industries: une huilerie - savonnerie SCIM, une brasserie STAR, des salines.
Hell-ville (Nosy Be)	Ville touristique avec plusieurs hôtels de classe internationale - une usine sucrière SNB-CE de Nosy Be, de petites usines d'essence d'ylang - ylang, usine crevetteière (étêtage, congélation, conditionnement, et expédition), les PECHERIES de Nosy Be PNB, ville agricole (ylang-ylang, poivre, cannelle).
Ambanja	Ville agricole (cacao, café, manioc etc.), une usine de féculerie.
Antalaha Sambava Vohimarina	Ces trois dernières villes sont à vocation agricole (palmiers à huile, café, banane, poivre,). Vohimarina est un port de cabotage principal tandis que Antalaha et Sambava, des ports de cabotage secondaires.

Faritany de Fianarantsoa:

Nosy Varika Mananjary Farafangana Manakara	Ces quatre villes côtières sont essentiellement agricoles (poivre, café, palmiers à huile, vanille, girofle). Manakara et Mananjary sont des ports de cabotage principaux.
---	---

Taux d'expansion

Pour les centres urbains ce taux est légèrement supérieur à 4 pour cent et pour les centres ruraux il est de 17 à 21 pour cent (tableau no 4 de la population des zones côtières dans annexe II).

Equipements collectifs dans le domaine de la santé, de l'assainissement et de la distribution d'eau

Dans le domaine de la santé

Les équipements collectifs sont les suivants:

- par Firaisam-pokontany, il y a au minimum un personnel paramédical qui travaille dans un dispensaire: un infirmier ou une sage-femme ou un aide-sanitaire; au maximum un infirmier et une sage-femme;
- par Fivondronam-pokontany, il existe un hôpital médico-chirurgical avec un médecin et un chirurgien et au minimum un hôpital avec un médecin;
- le chef-lieu de Faritany (province) possède un hôpital principal avec plusieurs médecins spécialistes.

Notons qu'en milieu urbain, en plus du dispensaire où travaillent plusieurs médecins, il existe un centre de Protection maternelle et infantile avec des docteurs. En milieu rural, il existe un centre de nivaquinisation géré par le Fokontany sans la présence du personnel de santé. Ce centre est visité de temps en temps par un personnel médical en tournée.

Dans le domaine de l'assainissement

Une brigade doit exister par circonscription médicale mais par exemple dans le Faritany (province) de Toliary deux seulement sur huit fonctionnent. Ces brigades sont actuellement en voie de formation. Le bureau régional de l'assainissement et du génie sanitaire se charge du maintien de la propreté dans le Fokontany. Il donne des directives sur la destinée des ordures, des eaux usées, la construction de W.C, la conservation de l'eau potable. Par Fokontany, une commission sanitaire veille à la propreté du village, à son assainissement, à la distribution de la nivaquine ou à encourager les gens pour se faire vacciner. Il faut cependant remarquer que cet objectif sanitaire n'est pas toujours respecté:

- les ordures traînent partout dans certaines villes;
- les égouts de la ville de Toamasina ne sont pas curés ou entretenus et les eaux putrides stagnent dans ces canalisations à ciel ouvert qui bordent les rues des quartiers peuplés;
- les ordures (ouates ou objets de pansement ou de maternité déjà utilisés) en provenance de l'hôpital furent jetées au bord de la mer (plage militaire de Tolagnaro) alors que les pêcheurs stockent leurs produits de pêche non vendus dans les trous de l'estran rocheux de cette même plage;
- les gens font leur besoin sur les plages qui servent de W.C public à Mananjary, Tolagnaro, Toliary, Morombe, Vatomandry.

Toutes ces remarques sont des sources de pollution et peuvent nuire à l'humanité.

Dans le domaine de la distribution d'eau:

Le gouvernement a pour objectif d'assurer à la population un approvisionnement suffisant en eau. D'après le tableau ci-dessous, on peut considérer le pourcentage du nombre des abonnés et le nombre de bornes fontaines comme un indicateur du progrès d'une ville. Ce tableau nous permet de dégager les dix premières villes

côtières bénéficiant des adductions d'eau (Antseranana, Vohimarina, Mahajanga, Toamasina, Mananjary, Mahajanga, Taolagnaro, Maintirano, Toliary, Morondava). Dans l'ensemble, il faut remarquer que le nombre de bornes fontaines publiques est très insuffisant: par exemple, un grand port comme Toamasina ne possède qu'une borne pour 2 000 habitants. Dans la plupart des cas, la population se contente de puits.

Distribution d'eau dans les zones littorales

Source: JIRAMA Antananarivo (Département des Eaux)

Localités	Longueur du réseau km	Nombre d'abon- nées	Nombre de bor- nes fo- ntaines	Nombre d'hab- itants	Longueur du réseau en m/ habitant	Nombre de bornes fontaines/ 1000 ha- bitants	% du nombre des abonnés
Antseranana	57,70	4 409	106	32 453	1,8	3,26	13,58
Vohimarina	11,26	335	18	4 135	2,1	4,35	8,10
Sambava	8,11	277	7	7 521	1,1	0,93	3,68
Antalaha	16,14	610	42	21 819	0,7	1,92	2,20
Sainte-Marie	7,82	59	20	7 103	1,1	2,81	0,83
Fenerive-Est	7,55	276	2	10 133	0,7	0,19	2,72
Toamasina	94,00	3 911	42	76 505	1,2	0,54	5,11
Vatomandry	7,31	en cours	en cours	5 033	1,4		
Mananjary	12	620	45	15 307	0,7	2,93	4,05
Manakara	19,44	500	33	23 314	0,8	1,41	2,14
Farafangana	12,76	418	25	15 633	0,8	1,60	2,67
Tolagnaro	33,46	882	37	19 108	1,7	1,93	4,61
Nosy Be	11,4	3	0	14 429	0,8		0,02
Mahajanga	74,62	4 655	318	71 843	1,0	4,42	6,48
Maintirano	11,57	396	16	9 800	1,2	1,63	4,04
Morombe	3,16	123	7	6 747	0,4	1,04	1,82
Morondava	15,52	829	89	28 200	0,5	3,15	2,93
Toliary	56,35	2 424	105	65 560	0,8	1,60	3,69



Nombre d'habitants vivant dans ces établissements

L'évolution de la population des zones côtières entre 1975 (recensement général fait par INSRE) et 1979 (celui effectué par le Ministère de l'Intérieur) est indiquée dans le tableau no 4. Le tableau suivant résume la population actuelle dans les différentes villes côtières:

Nombre d'habitants	nombre de villes	Noms des villes et établissements urbains
- 50 000 à 100 000	3	Toamasina (76 505) - Mahajanga (71 843) - Toliary (65 560)
- 20 000 à 50 000	5	Antseranana (32 453) - Morondava (28 200) - Manakara (23 314) - Antalaha (21 819) - Nosy Varika (20 920)
- 10 000 à 20 000	11	Tolagnaro (19 108) - Mananara-Nord (18 163) - Vangaindrano (15 678) - Farafangana (15 633) - Ambanja (15 619) - Mananjary (15 307) - Marovoay (15 118) - Hell-Ville (Nosy Be) (14 425) - Ambilobe (13 942) - Maroantsetra (13 149) - Fénérive-Est (10 133)
- 5 000 à 10 000	7	Maintirano (9 800) - Sambava (7 521) - Ambodifototra - Sainte-Marie (7 103) - Morombe (6 747) - Mahanoro (5 281) - Analalava (5 100) - Vatomandry (5 033)
- 2 000 à 5 000	9	Belo-sur-Tsiribihina (4 200) - Vohimarina (4 135) - Soalala (4 011) - Vavatenina (3 746) - Amboasary (3 315) - Vohipeno (3 100) - Besalampy (2 853) - Soanierana-Ivongo (2 803) - Ambovombe (2 329)
- 2 000	2	Brickaville (1 878) - Tsihombe - (1 021)

L'examen du tableau no 4 permet de voir les mouvements de la population de la ville vers la campagne (-) ou de la campagne vers la ville (exode rural (+)).

Effort entrepris en matière d'aménagement du territoire et de politique sociale

Habitat et alimentation en eau

Un des objectifs du gouvernement est de créer un habitat décent alimenté en eau potable. Les efforts seront axés sur deux plans:

- la construction de 20 000 logements qui seront répartis par "faritany" (province). Les constructions individuelles seront encouragées par la vulgarisation de la technologie de construction et la recherche des matériaux de construction à bon marché;

- l'installation des infrastructures:

alimentation en électricité des chefs-lieux de fivondronam-pokontany; étude d'un plan d'aménagement régional;

alimentation en eau potable: adduction d'eau pour 37 villes, étude en vue d'adduction d'eau pour 43 villes, étude et installation des plans directeurs de six villes par "faritany", aménagement de puits, ou construction d'impluvia et de citernes.

Développement social

La santé sera améliorée par des activités de prévention et d'éducation. Ces projets concernent le renforcement des infrastructures sanitaires, l'augmentation de la production des médicaments fabriqués sur place. Le sport, l'alphabétisation, l'information, l'animation, les vacances, le tourisme, seront encouragés et développés.

Les principales installations portuaires du littoral

Les ports de commerce de Madagascar, au nombre de 19, sont classés par décret en quatre catégories:

- port long-courrier principal: Toamasina;
- ports long-courriers secondaires: Antseranana - Mahajanga - Toliary;
- ports de cabotage principaux au nombre de huit: Tolagnaro, Manakara, Mananjary, Morombe, Morondava, Nosy Be, Port Saint-Louis (Ambilobe), Vohimarina;
- six ports de cabotage secondaires avec Analalava - Antsohihy, Antalaha, Maintirano, Maroantsetra, Ambodifototra (Sainte-Marie), Sambava.

Les ports long-courriers principaux et secondaires sont ouverts à tous les navires, tandis que les ports de cabotage ne le sont qu'aux navires de cabotage sauf sur autorisation spéciale. Les ports de cabotage secondaires ne sont, sauf sur autorisation spéciale également, ouverts qu'au trafic de cabotage national. En 1981, le nombre de navires qui ont touché les principaux ports long-courriers est le suivant:

Ports long -courriers	Nombre de navires	Nombre de "touchers"
Toamasina	106	184
Mahajanga	30	59
Antseranana	25	41
Toliary	10	20

## DEVELOPPEMENT INDUSTRIEL DU LITTORAL

Les complexes industriels du littoral sont résumés dans le tableau no 5 de l'annexe II. Malgré nos maintes interventions, certains parmi eux n'ont pas daigné répondre à nos questionnaires. Ceux qui sont signalés ci-après ont pu faire l'objet de visites et d'enquêtes sur place.

### Raffinerie SOLIMA de Toamasina (tableau no 5)

Depuis la nationalisation, la production de la raffinerie approvisionne les marchés de Madagascar et Comores, et de temps à autre la Réunion. L'excédent de fuel-oil est vendu sur le marché international (Europe, Asie du Sud-Est). Les types d'effluents sont de trois sortes:

- les effluents gazeux: sont constitués de gaz combustible ( $C_1 - C_2 - C_3 - H_2S$ ) provenant de la désulfuration des hydrocarbures. Ce gaz fatal est utilisé dans les fours pour donner du  $CO_2$ ,  $H_2O$  et  $SO_2$  qui sortent par les cheminées avec les vapeurs d'eau des chaudières. Les excédents de ce même complexe gazeux avec un peu d'hydrogène et d'acide sulfhydrique sont brûlés à la torche permanente haute de 36m;
- les effluents liquides formés d'eaux d'égoûts: avant d'emprunter des tuyaux souterrains les rejetant à la mer, les eaux usées de l'usine contenant un peu d'hydrocarbures subissent un traitement dans deux bassins A.P.I. (American Petroleum Institute). Un troisième bassin A.P.I. traite celles provenant des camions et des wagons-citernes. En principe, il y a séparation physique: les hydrocarbures HC surnageant sont récupérés dans un autre bassin et retraités avec le brut;

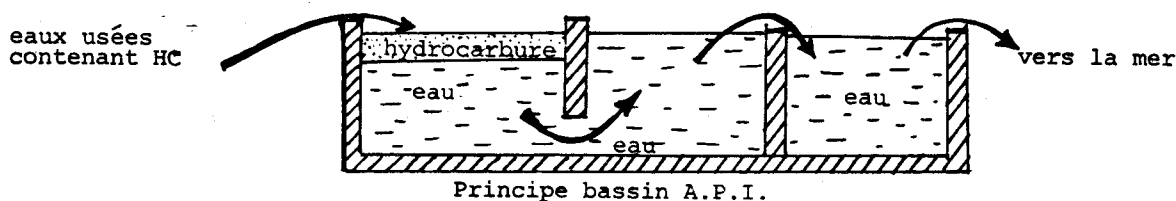

- les effluents solides sont les boues des bacs de stockage. Elles sont mises en fûts et brûlées dans un incinérateur au gas-oil.

En 1977, 248 personnes travaillaient dans cette raffinerie, tous des nationaux dont 15 cadres et 24 agents de maîtrise et agents techniques. En 1983 le nombre de personnel est de 365.

### SOMALAVALE (tableau no 5)

Cette société malgache des laques valentine fabrique de la peinture, du vernis et du diluant. Sa production de 2 000t en 1981 est destinée à la consommation locale pour 95 pour cent et à 5 pour cent pour l'exportation. Elle est tombée à 800t en 1982. On distingue d'après les responsables les effluents suivants:

- effluents liquides: Ce sont d'une part des eaux usées formées par les eaux de refroidissement des machines et d'autre part des eaux sodées provenant des lavages de cuves de fabrication des peintures. Toutes ces eaux sont évacuées à l'extérieur de l'usine par des canalisations. Malheureusement, elles s'accumulent pour former des eaux stagnantes différemment colorées dans l'enceinte du Centre Universitaire Régional de Toamasina. Ces mêmes eaux dégageraient une odeur répugnante pendant la saison chaude;
- effluents solides: Les papiers d'emballages des pigments et les cartons sont brûlés dans un incinérateur tandis que les boîtes de peinture usées au pon

C'est une société anonyme privée à 100 pour cent dont les fonds sont fournis par des nationaux et des étrangers. Le nombre de personnel est de 84 (1983).

SOVEMA ou Société Verrière Malagasy (tableau no 5)

C'est une société anonyme privée

- participation de l'état 31 pour cent;
- participation des étrangers 69 pour cent.

Par manque de matières premières, la production, avec six mois d'arrêt, s'élève respectivement à 9 668t de bocaux, de bouteilles et de verres à boire en 1980, 4 280t en 1981 et 5 338t en 1982. Cette production est destinée à la consommation locale pour 90 pour cent. Ses effluents se composent:

- des eaux usées provenant du refroidissement des machines. Elles sont recyclées après stockage pour faire refroidir les autres machines;
- des huiles de vidange des véhicules qui sont enterrées dans le sable ou brûlées.

C'est une industrie nationale privée, dont la population ouvrière est de 247.

Abattoir municipal

Quarante têtes y passent par jour, et les effluents sont:

- les eaux usées renfermant du sang (eaux de lavage des salles d'abattage) qui sont conduites jusqu'à la mer grâce à des canaux bétonnés à ciel ouvert; (d'après la population locale, ces eaux incitent la pullulation des requins dans les plages environnantes qui, par la suite, deviennent dangereuses);
- les excréta qui sont stockés non loin du rivage sur une aire non clôturée en attendant d'être récupérés, selon les besoins, par la municipalité pour fumer les jardins publics.

SNB-CE ou Société Nosy Be-Côte Est à Brickaville

Cette industrie agricole et alimentaire (sucrierie) produit du sucre de canne et de l'alcool destinés à la consommation locale et ses effluents sont les suivants:

- les écumes (2,18 pour cent de poids de cannes), déchets obtenus après extraction et filtrage du jus de canne traitée, qui servent d'engrais pour la culture;
- les mélasses (2,6 pour cent du tonnage des cannes), résidus de fabrication du sucre qui sont traitées (fermentation et distillation) pour la fabrication de l'alcool. Le résidu liquide récupéré ou vinasse est rejeté dans la rivière Rianila. C'est une société anonyme nationale : Etat 72 pour cent, étrangers 28 pour cent, dont la population ouvrière est de 400.

Abattoir Frigorifique National de Mahajanga (A.F.N.M.)

Cet établissement a une capacité annuelle d'abattage de 50 000 bovidés mais ce chiffre n'a jamais été atteint depuis sa création en mars 1979: 15 550 en 1979, 17 203 en 1980, 11 260 en 1981 et 10 462 en 1982. Cette production est destinée: à la consommation locale (15 pour cent), à l'exportation (85 pour cent). En ce qui concerne les effluents:

- le sang est transformé en farine de sang, tandis que la viande saisie l'est en farine de viande;

- les excreta sont stockés dans une enceinte spéciale: les produits solides sont vendus à titre symbolique aux cultivateurs; les produits liquides sont évacués dans la baie de Bombetoka par des canalisations plus ou moins naturelles qui traversent de très beaux champs de bananiers, de manioc, de canne à sucre.

C'est une industrie nationale, une société d'Etat à 100 pour cent; il y a 109 ouvriers pour l'abattage.

SIB ou Société Industrielle du Boina (tableau no 5)

Cette savonnerie et huilerie sise à Mahajanga consacre toute sa production d'huiles alimentaires et de savons à la consommation locale et celle des tourteaux en majorité à l'exportation avec 23 246t sur 27 429t en 10 ans soit 84,75 pour cent de la production. Les effluents sont:

- des eaux huileuses et l'excès de soude caustique provenant du lavage des huiles végétales ainsi que de la savonnerie. Elles subissent une décantation dans un bassin avant d'être conduites à l'extérieur, grâce à plusieurs centaines de mètres de canaux ouverts en ciment bétonné. Cependant ces eaux usées qui devraient être rejetées dans la baie de Bombetoka stagnent par effondrement de la partie moyenne de ces canaux élevés sur pilotis, sur une sorte de cuvette;
- les shoap stocks (déchets de filtre) qui sont repris pour la fabrication des savons noirs;
- les coques avec fibres de coton qui servent de combustibles;
- les coques d'arachide stockées dans un bassin à l'extérieur de l'enceinte puis incinérées.

C'est une société nationale privée 100 pour cent (capitaux étrangers) et la population travailleuse est de 200.

SEIM ou Société d'Entreprise industrielle de Madagascar (tableau no 5)

Sise à Mahajanga, les huiles alimentaires et les savons produits sont voués à la consommation locale. La société exporte cependant une partie des tourteaux (300t sur 1 218t en 1981 et 50t sur 883t en 1982). Les effluents sont les mêmes que pour la S.I.B.

- liquides: les eaux huileuses ou légèrement savonneuses sont évacuées à l'extérieur d'abord par des canaux à ciel ouvert, puis par des buses souterraines jusque dans la rue et stagnent sur un terrain vague correspondant à une ancienne mangrove remarquable par les quelques pieds d'Avicennia officinalis. Ces eaux usées couvrent une superficie de 300m<sup>2</sup> environ. On constate des écumes de couleur foncée. Signalons que la bordure de ce petit lac d'eaux usées présente une belle pelouse bien verte de graminées du genre Sporobolus, bien que furent constatés, il y a plusieurs années, deux cas typiques de la causticité de ces effluents: un malheureux zébu ayant piétiné cette mare y est resté figé pendant des heures; une voiture ayant traversé la chaussée à grande vitesse s'est vue décolorée au niveau des éclaboussures par suite d'une casse des canalisations d'effluent au niveau de la rue;
- les shoap stocks qui entrent dans la fabrication du savon noir;
- les déchets de filtre qui sont enterrés;

- les coques et fibres de coton qui servent de combustibles tandis que les cendres sont accumulés dans la cour ou récupérés partiellement par les petits paysans. La majorité sera donc rejetée en bordure de mer sur un pour cent pour l'exportation. En 1980, 36 millions de mètres de tissus contrôle l'eau huileuse, à la main et l'eau savonneuse avec excès de soude, reconnaissable à l'odeur et à la vue (couleur foncée, visqueuse et présence d'écumes).

#### FITIM ou Filature et Tissage de Madagascar (tableau no 5)

Cette industrie nationalisée depuis 1978 et située à Mahajanga fabrique des sacs, toiles et fils en paka et jute pour la consommation locale. Il n'existe pas de véritables effluents: l'étope est récupérée et brûlée dans les chaudières. La population travaillante est de 800.

#### CIMALGA ou Compagnie des Ciments Malgaches d'Amboanio

La production de cette compagnie est vouée à la consommation locale avec un maximum en 1978 (77 000t) pour une capacité de croisière de 60 000t/an, mais après 1978 le chiffre n'a de nouveau dépassé 38 000t qu'en 1982 avec 50 000t. Ses effluents sont:

- gazeux sous forme de gaz carbonique  $CO_2$  éliminé dans l'atmosphère par une cheminée de 50m de haut (la plus haute de Madagascar);
- solides: les poudres de ciment éparpillées dans toute la cour de l'usine; les excréments déposés par les ouvriers dans les environs proches de l'usine (à une dizaine de mètres et dans les mangroves) qui infestent les alentours. Les morceaux de papier fort (sachets de ciment) s'accumulent sur le bord. Cette pollution atmosphérique et aquatique provient du non fonctionnement des W.C;
- liquides: les eaux huileuses, en particulier les huiles des moteurs de la centrale électrique vidangés après 200 heures de marche qui s'étendent sur la vase rouge latéritique de la mangrove située au bord de la baie de Bombetoka.

Cette société est nationalisée depuis 1980 (100 pour cent) et sa population travaillante est de 464.

#### JIRAMA ou Jiro sy Rano Malaqasy (Electricité et Eaux de Madagascar)

Située à Mahajanga, cette société nationale utilise comme source d'énergie du fuel-oil. Malheureusement, le transfert par pipeline de cet hydrocarbure du bateau-citerne à l'usine se fait mal, et laisse des traces reconnaissables par les galets colorés en noir brillant sur la plage latéritique découverte à marée basse.

#### SOTEMA ou Société Textile de Majunqa (Mahajanga)

Cette usine de filature, de tissage, de teinturerie et de confection consacre ses 90 pour cent de production pour la consommation locale et 10 pour cent pour l'exportation. En 1980, 36 millions de mètres de tissus fabriqués passent à 36,7 millions de mètres en 1981 et retombent à 32 millions en 1982 par manque de matière première. La capacité maximale de 65 millions de mètres n'est jamais atteinte. Ses effluents sont tous liquides:

- les excédents de vapeurs d'eau des chaudières ne renferment pas de produits chimiques donc ne sont pas toxiques: elles s'échappent par de petites cheminées;

- les eaux en provenance des chaudières sortent de l'usine par des canaux; bien que limpides elles laissent déposer des tartres;
- les eaux colorées non traitées contenant des produits chimiques (naphtol, NaCl, produits de droguerie pour teindre les tissus) à basse concentration, sortent par des évacuations naturelles sans bassin de décantation. Toutes ces catégories d'eaux usées semblent n'avoir aucune influence sur les plantations de cannes à sucre traversées. C'est une société nationale dont la population ouvrière était de 4 259 ouvriers et cadre en 1981.

#### SOMIA ou Société Malgache d'Industrie et d'Agriculture

Cette société, dont le siège est à Mahajanga possède des zones de plantations diverses et dispersées dans toute l'île. L'industrie du sisal d'Amboasary-Sud (province de Toliary) produit 2 000t par an dont 90 pour cent exportés sous forme de fibres. Ses effluents sont les eaux de lavage du sisal qui sont très acides: 100 m<sup>3</sup> par tonne de sisal soit 200 000 m<sup>3</sup> de ces eaux par an d'après les responsables. (Système d'élimination: non signalé). C'est une industrie étrangère (forte participation étrangère, presque 100 pour cent), dont la population ouvrière est de 700 (culture et traitement).

#### SICA ou Société Industrielle et Commerciale Abdulla

Toute la production de cette Huilerie et Savonnerie dont le siège est à Morondava est destinée à la consommation locale. Seule une partie des tourteaux est exportée (sans précision). Ses effluents doivent être les mêmes que pour les autres huileries et savonneries. Le gérant signale comme moyen d'élimination, l'égoût. C'est une industrie privée étrangère, dont la population ouvrière est de 28.

#### S.N.H.U. ou Société Nouvelle des Huileries de Toliary

Cette société comprend également une savonnerie et sa production est destinée à la consommation locale. Les effluents sont les mêmes que précédemment. Les effluents liquides accumulés dans un grand bassin externe attendraient peut-être un traitement. Cette entreprise comprenait avant sa fermeture (début 1983) 491 ouvriers.

### GOUVRAGES HYDRAULIQUES ET INSTALLATIONS HYDROELECTRIQUES DU LITTORAL ET DE L'ARRIERE - PAYS

#### Principaux ouvrages hydrauliques influant sur le littoral et les eaux côtières

Deux grandes centrales hydroélectriques: ANDEKALEKA (116 MW) et NAMORONA (5 000 KW) aménagées respectivement sur les rivières Vohitra et Namorona semblent, d'après la Jirama, n'avoir aucune influence sur l'environnement.

Le barrage de Dabara construit sur la rivière Morondava à Morondava pour irriguer la plaine de Morondava (SODEMO) de 2 000 ha environ est soupçonné pour être la cause de l'érosion du littoral de la ville, bien que le Service du Génie rural ne la reconnaît pas. Constitué: - d'un seuil déversant en béton armé de 200m environ, protégé par une digue en terre de 380m de long; d'une prise à 2 pertuis munis de vannes; d'un dessableur à 2 bacs de 10m de large, 100m de long et 5m de profondeur à l'étiage. Le débit dérivé est de 24 m<sup>3</sup>/s. D'après le service du Génie rural, étant donné le débit dérivé faible par rapport au débit de la rivière, la mise en place de

la prise n'affecte nullement les régimes naturels. La mise en place du seuil déversant entraîne un réhaussement du lit amont par rapport à sa côte initiale mais sans gravité.

#### Cause de l'érosion côtière de la ville de Morondava (d'après Neuvy, G.)

Deux phénomènes importants ont une incidence sur la stabilité du secteur côtier de la ville de Morondava: les captures périodiques entre les rivières Kabatomena et Morondava d'une part, et les nappes artésiennes, d'autre part. Si la Kabatomena a le plus fort débit, elle apporte du sable dans la mer qui le transporte sur la plage de Morondava. Si la rivière Morondava a le plus fort débit, le sable continental arrive au nord de la ville et s'en éloigne: ce qui favorise l'érosion de la côte. A marée basse, des résurgences d'eau douce apparaissent sur la plage, et à la suite d'une saison très humide, il peut y avoir phénomène de boulangage par courant ascendant, particulièrement redoutable pour les lourds ouvrages comme les épis monoblocs destinés à protéger la côte.

En outre, la construction de barrage de Dabara pour la mise en valeur de la plaine de Morondava perturbe le cheminement du sable vers la mer. La déviation du canal Hellot vers la passe de Betania en 1950-1951 a fermé l'ancienne embouchure située à l'extrémité Sud de la ville. La nouvelle embouchure est à proximité de la ville. De ce fait, la passe Hellot n'existant plus, Morondava est mal protégée.

La conjoncture d'événements la plus menaçante pour l'existence de Morondava serait la suivante: une forte tempête cyclonique par haute mer, en marée de vive eau exceptionnelle, en houle de régime ouest-sud-ouest fin mars, après une série d'années très humides. La probabilité d'une telle conjoncture est faible, mais pas impossible.

### TRANSPORT

#### Modes et moyens de transport sur le littoral et dans les eaux côtières

La navigation portuaire est effectuée par des embarcations de servitude liée au port d'attache:

- les chalands, bateaux à coque métallique, à fond plat utilisés comme moyens de transbordement de marchandises, d'un navire long courrier ou d'un gros caboteur mouillé au large au port de batelage, ou comme moyens de stockage temporaire;
- les remorqueurs se déplaçant à l'intérieur du port pour faciliter les manoeuvres d'accostage et de décostage des navires ou aussi pour traîner les chalands.

La navigation au bornage est assurée par:

- les boutres, à deux mâts construits avec des planches monongo (g. Xanthoxylon). Ils peuvent transporter jusqu'à 30 tonnes de marchandises ou de produits locaux (riz, manioc, ciment, etc.) d'une ville côtière à une autre;
- les goélettes, genre de boutres à un mât, motorisés ou non, utilisées surtout sur la côte Ouest.

La navigation au cabotage est pratiquée par les petits caboteurs et les gros caboteurs transportant un fort tonnage de marchandises entre les différents ports du



pays tandis que la navigation au long cours est assurée par les longs courriers qui affrètent les marchandises en provenance ou à destination des pays étrangers.

Remarquons que:

- le transport de personnes par voie maritime reste négligeable par rapport à celui par voie routière. Les bateaux ne transportent que des marchandises;
- certaines pirogues à voile de grande taille (8m) de la côte sud-ouest construites en une seule pièce avec de gros troncs d'arbres (à bois léger) et pourvues d'un balancier, peuvent transporter 8 à 10 personnes ou une charge de plus d'une tonne, d'un village côtier à un autre. Non immatriculées, elles jouent un rôle primordial dans la pêche artisanale.

#### Volume du commerce international

Pour Madagascar, quatre principaux ports assurent le transit: Toamasina, Mahajanga, Antseranana et Toliary. En 1981, le volume global du commerce international s'élève à 1 288 645t - importations et exportations comprises.

Le trafic à l'importation pour 1981 a atteint 987 524 tonnes dont 954 252,289t c'est-à-dire les 96,6 pour cent débarquées ont été passées aux quatre ports énumérés ci-dessus et le reste à Hell-Ville et à Tolagnaro (tableau no 6, annexe II). Les 33 271,711t restantes, soit les 3,4 pour cent des marchandises importées, ont été débarquées à Hell-Ville et à Tolagnaro. Ce tableau montre l'importance de l'importation des hydrocarbures (417 320t) qui représentent 42,26 pour cent du total des importations, viennent ensuite le riz (16 pour cent), le ciment (11,98 pour cent), etc. Le port de Toamasina reste de loin le premier port de Madagascar avec 703 241t de marchandises débarquées, puis viennent Mahajanga 115 566t, Antseranana 84 102,289t et Toliary 51 353t. Le trafic à l'exportation (1980-82) se résume dans le tableau no 8 de l'annexe II.

#### Flotte Nationale (source: Direction de la marine marchande-Antananarivo)

La navigation portuaire comprend:

1981 : 205 chalands et remorqueurs de T.J.B = 10 204,265  
1982 : 349 chalands et remorqueurs de T.J.B = 17 767,02

Les bateaux de plaisance:

1980 : 142 bateaux de T.J.B = 591,438  
1981 : 169 bateaux de T.J.B = 611,08  
1982 : 178 bateaux de T.J.B = 683,43

La navigation traditionnelle effectuée par les goélettes et les boutres recensés par les services provinciaux de la marine marchande (S.P.M.M.) se répartissent comme suit:

S. P. M. M.	G o é l e t t e s		B o u t r e s	
	Nombre	Jauge brute	Nombre	Jauge brute
Toamasina	2	59,08	-	-
Antseranana	1	69,85	56	393,72
Mahajanga	17	357,17	73	773,84
Toliary	92	2 102,23	-	-
Total	112	2 588,33	129	1 167,56

En 1982, le tonnage réalisé par ces moyens de transport se chiffre à 8 496t à l'embarquement et à 10 890t au débarquement pour tous les ports malgaches.

#### La flotte de pêche industrielle

En 1981 et en 1982, cette flotte comprenait le même nombre total de 46 navires de longueur supérieure ou inférieure à 24m suivant le tableau ci-après:

Année	Nombre de navires	Longueur	T.J.B	T.P.L.
1981	19	plus de 24m	3 185,85	700
	27	moins de 24m	2 042,30	799,5
Total	46	-	-	-
1982	24	plus de 24m	3 840,85	1 035
	22	moins de 24m	1 450,86	495,5
Total	46	-	-	-

### La flotte au commerce

De 1981 à 1982, le nombre de bateaux varie très peu, de 13 à 14 pour le gros cabotage et de 38 à 44 pour le bornage. Le tableau ci-dessous donne une idée de cette flotte en 1982.

Genre de navigation	Nombre	T.J.B	T.P.L
Longs-courriers	4	42 296,14	60 791
Cabotage supérieur à 500 TJB	14	30 437,99	38 781,8
Cabotage inférieur à 500 TJB	15	3 736,85	4 241
Bornage	44	3 479,38	-

Remarquons que pour tous ces genres de navigation, le nombre de marins immatriculés auprès des services provinciaux de la marine marchande (S.P.M.M) augmente de 1979 à 1982.

Années S.P.M.M	1979	1980	1981	1982
Antseranana	469	488	541	539
Mahajanga	928	954	948	1 015
Toamasina	361	430	463	505
Toliary	112	143	119	121
Total General	1 870	2 015	2 071	2 180

### Incidences du transport sur les écosystèmes

#### Ordures rejetées dans le port

Les navires au quai effectuent uniquement des opérations commerciales. En général, l'évacuation des décombres, ordures, caisses fécales, matières quelconques, résidus et eaux de nettoyage des cales et soutes des navires ayant contenu des huiles végétales ou minérales, s'effectue en haute mer (à 30 milles des côtes). Il en est de même du dégazage et du déballastage des navires pétroliers. Quelquefois cependant, ce règlement n'est pas respecté et l'on trouve parfois des flacons ou des boîtes vides de boisson flottant à la surface de l'eau. Il y a quelques années les eaux de Toliary étaient polluées par du mazout qui s'était peut-être échappé d'un bateau à quai. Cette odeur de gas-oil envahissait la région.

#### Bâteaux en échouage

Pour des raisons humaines, on laisse entrer en rade les cargos chargés en état de détresse. Les carcasses de ces bateaux abandonnés dans les baies de Toliary, de Tolagnaro et d'Antseranana rappellent les pollutions atmosphérique et aquatique occasionnées après leur échouage:

- du bateau grec chargé de farine échoué à Tolagnaro, il y a une dizaine d'années, s'exhalaient des odeurs nauséabondes infestant des kilomètres tout autour;
- le bateau grec transportant du charbon de terre et incendié avait brûlé pendant toute une année dans le lagon du Grand Récif de Toliary. Ce qui a provoqué une pollution thermique entraînant certainement la disparition de la flore et de la faune marines dans le voisinage immédiat.

### Manipulation au quai

Il y a deux ans, le débarquement des fûts de goudron sur le quai de Toliary, fûts peut-être manipulés sans beaucoup de soin, a entraîné, non seulement le salissement du quai mais aussi la pollution des eaux jusque sur les plages où l'on a pu rencontrer des plaques solides noires, de plusieurs décimètres carrés.

Actuellement, la rencontre très fréquente sur la pente externe au niveau du front récifal, c'est-à-dire dans la partie vivante des récifs de Toliary, et plus au nord, sur le récif frangeant de Songoritelo, des squelettes blanchis donc morts, de madréporaires branchus, laisse supposer la conséquence de l'effet d'une pollution quelconque de grande ampleur qui touche ces écosystèmes assez fragiles que sont les récifs coralliens.

### Projet de développement des installations de transport (ports)

Le développement des ports est lié au plan des transports qui est à l'étude.

## EXPLOITATION DES RESSOURCES BIOLOGIQUES DE LA TERRE (CF. ANNEXE III)

### Le coton

Les statistiques de la production et des exportations fournies par le Bureau et Caisse de Stabilisation des Prix du Coton se résument dans les tableaux suivants:

Production Années	Quantité en tonnes	Valeurs en Fmg
1970	18 714	928 960 000
1971	21 695	1 286 988 000
1972	23 882	1 419 560 000
1973	30 628	1 823 368 000
1974	32 290	2 044 064 000
1975	30 728	2 137 448 000
1976	34 731	2 658 831 000
1977	37 081	2 830 153 000
1978	33 087	2 799 135 000
1979	30 443	2 577 131 000
1980	23 160	2 200 200 000

Coton - fibre (fibres uniquement)

Années	P r o d u c t i o n		E x p o r t a t i o n		% de la production exportée	
	Quantité tonnes	Valeur Fmg	Quantité kg	Valeur Fmg	Quantité	Valeur Fmg
1970	7 150	1 151 150 000				
1971	8 290	1 616 550 000	601 013	100 846 500	7,25 %	6,23 %
1972	9 125	1 779 375 000	139	55 400	0,002%	0,004%
1973	11 700	2 281 500 000	1 040 151	245 726 000	8,89 %	10,77 %
1974	12 720	2 429 520 000				
1975	11 740	2 923 250 000	295	62 000	0,003%	0,003%
1976	13 270	3 317 500 000	1 486 049	355 946 200	11,19 %	10,73 %
1977	14 165	3 541 200 000	500 507	223 622 400	3,53 %	6,31 %
1978	12 630	3 577 120 000	4	5 000		
1979	11 630	3 291 290 000	465 549	175 307 600	4,01 %	
1980	8 850	2 908 331 000				

Graine de coton (graines sans fibres)

Années	P r o d u c t i o n		E x p o r t a t i o n		% de la production exportée
	Quantité en tonnes	Valeur en millions Fmg	Quantité en tonnes	Valeur en millions Fmg	
1970	11 230				
1971	13 020				
1972	14 330	179,1	983,5	16	6,86
1973	18 380	229,8	8 817,2	162,1	47,97
1974	19 980	249,8	2 439,8	62,4	12,21
1975	18 450				
1976	20 840	416,8	0,1		
1977	22 250	489,5	4 700	145,8	21,12
1978	19 855	436,8	0		
1979	18 265	401,8	0		
1980	13 300	332,5	0		

La culture du cotonnier (*Gossypium hirsutum*) est localisée principalement sur les zones côtières occidentales de l'Ile : Ambilobe, Mahajanga, Belo-sur-Tsiribihina Morondava, Morombe, Toliary (annexe III, fig. 2).

Les divers modes d'exploitation en culture cotonnière sont:

- la culture en paysannat individuel: le paysan est le producteur du coton. Il achète les biens et services à une structure d'encadrement à laquelle il vend sa production. Ce mode d'exploitation est celui du paysannat d'Ambilobe, de Mampikony, de Manja, d'Ankazoabo, du Moyen Fiherenana et de la Sedefita dans le delta du Fiherenana;
- la culture en paysannat collectif: Le paysan est intégré dans une structure de production comme la Samangoky. La structure réalise pour le paysan la préparation des sols, les traitements insecticides et fournit les semences,

engrais, insecticides. Le paysan qui effectue tous les travaux de semis, d'entretien des cultures et des récoltes, est rémunéré de son travail par la structure de production qui lui achète son coton à un prix fixe indépendamment des biens et des services fournis;

- la culture industrielle: Elle s'effectue dans des exploitations dont les surfaces en culture cotonnière sont en général supérieures à 50 ha. Ces exploitations utilisent de la main-d'oeuvre salariée. Il existe des entreprises privées et des entreprises para-administratives dépendant de plusieurs organismes qui en assurent la gestion (Ministère de l'Agriculture, Fermes d'Etat, C.E.A.M.P. et HASYMA).

Statistiques sur les engrais chimiques et les pesticides

Elles se résument dans le tableau suivant pour les quatres régions d'Ambilobe, Mahajanga, Toliary, Morondava.

Statistiques sur les engrais chimiques et pesticides utilisés dans la culture du coton de 1973-1982

An n é s	1973	1974	1975	1976	1977	1978	1979	1980	1981	1982
	Superficie totale (ha)									
Engrais	2 874 549	3 334 012	3 017 970	3 450 601	3 724 375	3 803 815	3 589 830	3 163 602	2 771 251	3 280 838
Urée	643 196	160 155	25 450	3 100	-	-	-	200	-	-
Sulfate d'ammonium	96 850	48 450	64 085	166 788	171 342	192 795	39 000	143 030	253 777	281 599
Phosphate d'ammonium	122 650	1 161 990	1 055 400	1 608 639	1 753 514	1 716 235	1 817 544	1 427 399	1 373 867	1 010 716
Sulfate de potassium	-	8 300	40 141	57 665	65 871	54 324	76 793	55 122	53 761	65 249
Boracine	23 882	24 671	713	7 125	30 163	30 615	8 377	24 701	21 670	23 149
Solubor	-	-	-	-	-	-	150	750	-	-
Superphosphate triple	-	-	-	-	-	-	-	-	-	-
Insecticides	-	-	-	-	-	-	-	-	285 188	175 127
Mono DDT 10/30	80 324	43 901	4 833	400	-	-	-	-	-	-
Endrin DDT 10/40	472 311	779 002	253 395	302 392	107 760	5 249	2 120	-	-	-
Mono DDT 80/274	-	-	-	-	323 460	493 588	428 786	349 854	143 788	12 278
Mono DDT 10/34	32 400	53 047	1 665	34 674	7 063	6 456	1 665	208	-	-
Azodrin 55,2	-	-	-	127 561	126 716	146 300	154 097	143 997	86 975	45 295
Nuvactron 40	21 000	8 795	350 188	300 412	513 411	375 027	458 495	7 340	2 168	1 321
DDT 35	-	-	-	159 025	119 200	1 800	-	294 060	143 219	68 033
DDT 40	-	-	-	-	14 860	-	-	-	-	-
DDT 50	-	-	-	-	-	1 052	309	-	-	-
Carboryl	-	-	-	-	-	-	850	-	6 410	23 800
Decis EC 2,5	-	-	-	-	-	-	6 723	30 724	52 695	95 775
Decis ULV 0,5	-	-	-	-	-	-	425	136	10	-
Sumicidin EC 20	-	-	-	-	-	-	3 681	-	673	164
Sumicidin ULV 2,5	-	-	-	42	40	25	-	125	-	-
Benlate	-	606	322	-	-	-	-	-	-	-
Dimethoate	-	-	-	-	-	-	270	-	-	-
Decis EC 1,25 D	-	-	-	-	-	-	-	24 099	39 118	7 947
Fluometuron 80	5 813	7 840	9 984	17 298	4 708	74	228	-	-	-
Fluometuron 500	-	-	-	-	18 425	23 506	17 799	16 792	12 900	18 238
Trifluraline	-	-	-	-	-	-	-	-	-	-
Cypral 200 EC	-	-	-	-	-	-	-	-	-	9 437
Cypral ULV	-	-	-	-	-	-	-	-	-	26 164

Source: Direction de HASYMA ou HASY MALAGASY (ou COTON MALGACHE)

La canne à sucre

La Canne à sucre est cultivée dans presque toutes les régions de Madagascar: d'une part en petites plantations paysanales destinées à la consommation familiale, d'autre part en cultures industrielles concentrées dans les régions côtières à conditions écologiques favorables : Ambilobe et Namakia - Mahajanga (SIRAMA = SIRAMAMY MALAGASY = Sucre de Madagascar) et Nosy Be et Brickaville - Toamasina (SNB-CE ou SUCRERIE Nosy Be - Côte Est). Actuellement l'usine SIRANALA de Morondava va fonctionner dans quelques mois (annexe III, fig.4).

Les statistiques de la production, de l'écoulement de la Canne et du Sucre se résument dans le tableau suivant (remarquons que ne figurent pas ici les produits dérivés de la canne):

Années	Cannes broyées tonnes	Sucre produit tonnes	Ventes locales (sucre)		Exportation (sucre)	
			Quantité tonnes	Valeur Fmg (au départ)	Quantité tonnes	Valeur F.O.B. Fmg
1977	1 033 634	109 965	82 207	4 352 465 732	26 350	1 719 643 178
1978	1 074 421	115 939	83 613	4 427 344 127	23 210	1 584 105 056
1979	1 017 271	109 292	86 115	6 217 235 613	19 580	1 439 473 232
1980	1 048 420	109 037	92 747	6 717 988 636	29 250	3 613 831 877
1981	1 055 059	104 699	80 398	6 905 313 852	12 200	2 642 798 894 <sup>a/</sup>
1982	848 136	82 159	81 122	11 423 077 612	10 500	1 146 970 255 <sup>a/</sup>

<sup>a/</sup> chiffres provisoires

Source: Bureau et Caisse de Stabilisation du sucre. Enquêtes sur place.

L'agriculture mécanisée utilise des chenillards pour le labour, des tracteurs pour le hersage et le sillonnage. Les plantations se font en ligne espacées de 1,30m avec des boutures à trois yeux.

Statistiques sur les engrais chimiques et les pesticides

Les données obtenues ne sont pas complètes car certaines sociétés sollicitées n'ont pas daigné répondre. Aussi la liste des produits chimiques achetés par ces sociétés sucrières chez un importateur et présentée ci-dessous, demeure également incomplète.

L'effectif de la population y travaillant est comme suit:

SIRAMA (Namakia) : Total 5.172  
 SNB-CE (Brickaville) : cultures, 2 000; usines, 400; Total, 2 400  
 SIRAMA (Ambilobe) : pas de données  
 SNB-CE (Nosy Be) : pas de données

Techniques traditionnelles

On utilise surtout les bouts blancs qu'on plante obliquement dans la terre, de préférence dans des régions irriguées ou non loin de la nappe phréatique. Avant la coupe, on n'effectue pas de brûlis du champ de canne, et on coupe la canne à la main avec une machette.



Engrais et pesticides vendus aux sociétés sucrières par S.E.P.C.M. de 1979-1982

A n n é e s	1 9 7 9			1 9 8 1			1 9 8 2			TOTAL
	SIRAMA	SNB-CE	TOTAL	SIRAMA	SNB-CE	TOTAL	SIRAMA	SNB-CE	SIRANALA	
A. Pesticides										
T.C.A (kg)	2 900	5 600	8 500	-	-	-	-	-	-	-
U 46 D Ester HV720 G/L(1)	2 200	22 310	24 510	7 140	-	7 140	-	-	-	-
Propanyl (1)	10 106	-	10 106	-	-	-	-	-	-	-
U 46 D Fluid 720 G/L	-	-	-	840	-	840	-	-	-	-
Actril DS (1)	200	1 200	1 400	450	-	450	-	-	-	-
Round Up (1)	100	-	100	-	-	-	-	-	-	-
Gramoxon (1)	-	4 908	4 908	-	-	-	-	-	-	-
Asulox (1)	-	6 400	6 400	-	-	-	-	-	-	-
Diuron 80% WP (kg)	-	8 700	8 700	-	2 200	2 200	4 000	-	-	4 000
Dalapon (kg)	-	2 700	2 700	-	-	-	-	-	-	-
Atrazine (kg)	-	300	300	-	-	-	-	-	-	-
Debroussaillant Concentré (1)	-	200	200	-	-	-	-	-	-	-
Etaldyne (1)	-	400	400	-	-	-	-	-	-	-
Ronstar PL kg	-	-	-	-	-	-	900	-	-	900
Ronstar 12 L (1)	-	-	-	-	-	-	100	-	-	100
Sel d'amine (1)	-	-	-	-	-	-	400	-	-	400
B. Engrais										
Sulfate de potasse (tonnes)	1 290	400	1 690	1 450	-	1 450	1 817	-	-	1 817
Chlorure de potasse (t)	875	650	1 525	550	-	550	650	-	-	650
Sulfate d'ammoniaque (t)	3 390	-	3 390	-	-	-	-	-	-	-
Sulfonitrate d'ammoniaque (t)	1 080	-	1 080	-	-	-	1 357	-	-	1 357
Ammonitrate calcaire (t)	-	-	390	-	-	-	-	-	-	-
Ammonitrate 26% (t)	-	-	-	-	-	-	-	105	-	105
Phosphate bicalcaire (t)	-	-	-	-	-	-	210	-	-	210
Urée(t)	-	-	-	-	-	-	-	-	100	100
N.P.K 10-10-20 (t)	-	-	-	-	-	-	-	-	425	425
Fleur de chaux (t)	-	-	-	-	-	-	-	100	-	100

Source: Vente de la Société d'Engrais & Produits chimiques de Madagascar (Importateur)

## Le girofle

Sa culture s'étend uniquement sur la côte Est de Sambava à Antalaha, de Maroantsetra à Vangaindrano (annexe III, fig. 5), sur une superficie de 30 000 à 35 000 ha (1972). Les statistiques de production, de vente et d'exportation fournies par le Bureau et Caisse de Commercialisation et de Stabilisation des Prix du Café, de la Vanille et du Girofle se résument dans le tableau suivant:

Campagnes	Production en tonnes	Prix du kg aux producteurs	Vente en millions Fmg	EXPORTATION		
				Quantité en tonnes	Valeur FOB en millions Fmg	% de la production exportée (poids)
1970/71	12 000	250 Fmg	3 000	5 278	4 696	43,98
1971/72	3 600	275	990	7 495	5 736	208,19
1972/73	6 100	280	1 708	6 019	4 139	98,67
1973/74	1 700	290	476	6 256	4 150	368
1974/75	23 000	320	7 360	21 636	16 767	94,07
1975/76	4 500	320	1 440	7 160	6 181	159,11
1976/77	10 600	320	3 392	3 091	3 824	29,16
1977/78	11 850	340	4 029	10 960	13 993	92,49
1978/79	10 800	340	3 672	17 940	22 347	166,11
1979/80	3 700	385	1 424,5	4 481	6 673	121,11
1980/81	11 027	395	4 355,7	6 273	13 941	56,89
1981/82	10 237	430	4 401,9	11 512	29 777	112,45

### Agriculture

On ne peut pas parler d'une véritable agriculture: la conduite des travaux culturaux reste insignifiante et même négligée. C'est une activité de cueillette. Le girofler (*Eugenia*) est un arbre qui peut atteindre 75 ans. Pour avoir un bon rendement, P. Hubert conseille de la planter avec un écartement de 7m x 7m, c'est à dire 200 pieds à l'hectare. Il faut laisser les interlignes propres et jusqu'à 20 ans, on intercale des cultures vivières ou des légumineuses de couverture pour empêcher l'érosion.

### Statistiques sur les engrais chimiques et les pesticides

Pas de données mais P. Hubert conseille l'utilisation de fumure organique, telle que des déchets de corne, du sang desséché, des tourteaux; et de la fumure minérale (sulfate d'ammoniaque, phosphates naturels, du chlorure de potassium).

### Techniques traditionnelles

La récolte du girofle se fait à la main d'octobre à décembre. Un ouvrier peut récolter 30 à 40 kg d'inflorescences, c'est-à-dire 25 à 30 kg de clous frais par jour. La production d'essence de girofle joue un rôle de régulateur de revenu pour les paysans: son extraction se fait grâce aux feuilles. Si la coupe des feuilles qui a lieu de janvier en avril, donc après la cueillette des fleurs (clous), réduit la hauteur des girofliers et protège ceux-ci contre les vents et facilite les travaux de la récolte, néanmoins la finalité principale de la coupe reste l'alimentation des alambics en feuilles. Les besoins d'argent du distillateur dépassent souvent la période acceptable de la coupe et la distillation gêne alors la production de clous. Le girofler devient de moins en moins fructifère. (Ranaivoarisoa, Th., 1980).

Le poivre

Sa culture se localise à Nosy Be, Sambirano, Vohimarina, Sambava, Antalaha, de Toamasina à Mahanoro, de Mananjary à Farafangana (annexe III, fig.3). Le poivre exporté, qu'il soit blanc, noir ou vert appartient à l'espèce *Piper nigrum*. Le poivre noir est la baie entièrement séchée, généralement cueillie avant complète maturité, présentant une couleur allant du brun au noir, et une surface ridée. Le poivre vert est la baie cueillie bien avant la maturité et vendue soit en grappe, soit égrenée et conservée dans de la saumure ou du vinaigre. Le poivre blanc est la baie débarassée de son épicarpe et de son mésocarpe externe. Il faut 3 kg de poivre vert arrivé à maturité pour obtenir 1 kg de poivre noir. La production de Madagascar en poivre blanc, presque marginale, échappe à tout contrôle, notamment statistique.

L'évolution de la production et des exportations du poivre vert et du poivre noir selon le Bureau et Caisse de Commercialisation et de Stabilisation des Prix du Poivre, est indiquée dans les tableaux suivants:

POIVRE VERT

Années	Production		Exportation		% de la production exportée (poids)
	Quantité (tonnes)	Valeur en millions de Fmg	Quantité (tonnes)	Valeur FOB millions de Fmg	
1971	200	20	149,8	120,3	74,9
1972	400	40	360,7	182,8	90,18
1973	600	60	547,1	270,8	91,17
1974	700	70	657,3	285,1	93,9
1975	800	80	633,7	290,9	79,21
1976	1 000	100	985	454	98,5
1977	1 000	100	1 065	572	106,5
1978	1 000	100	587,7	328,1	58,77
1979	1 000	100	676,5	316,7	67,65
1980	1 000	100			

POIVRE NOIR

Années	Production		Exportation		% de la production exportée (poids)
	Quantité (tonnes)	Valeur en millions de Fmg	Quantité (tonnes)	Valeur en millions de Fmg	
1970	3 000				
1971	3 000	375	1 284	315,1	42,8
1972	3 600	540	3 825	821,5	106,27
1973	3 500	525	3 193	755	91,22
1974	3 200	480	2 241,1	762,3	70,03
1975	3 200	576	3 461,2	1 071,5	108,16
1976	2 800	504	2 958,2	1 066,1	106,61
1977	2 600	481	2 682,8	1 253,8	103,18
1978	2 500	487,5	1 565,7	742,3	62,62
1979	2 500	487,5	1 893,7	654	75,75
1980	2 500	500	2 640,8	564,5	105,63
1981	2 500	562,5			

NB: Les chiffres supérieures à 100 pour cent indiquent que l'exportation comprend une partie de la production de l'année précédente.

## L'agriculture

Le poivrier ne donne pas lieu à une plantation proprement dite, à l'exception de quelques timides essais en cours. Cette liane se trouve surtout en culture associée dite "d'appoint" pratiquée ordinairement sur les arbres d'ombrage des caféiers et rarement comme culture de "case" sur les arbres qui entourent l'habitation du paysan. Il s'avère par la suite difficile de dresser un inventaire des superficies plantées. Cette surface a été évaluée à 1 800ha en 1972. La cueillette se fait à la main en mai-juin à Nosy Be pour le poivre vert et en avril-mai sur la côte Est. Le poivre noir se récolte entre juillet-septembre à Nosy Be - Sambirano et sur la côte Est, elle a lieu de juillet à août.

### Statistiques sur les engrais chimiques et les pesticides

Pas de données statistiques obtenues mais P. Hubert signale toutefois que le poivrier a besoin de fumure organique et de fumure minérale: phosphate tricalcique, dolomie, chlorure de potassium.

### Techniques traditionnelles

Le poivrier a besoin de tuteurs morts (grands piquets de bois de 3 à 5m de haut) ou de préférence de tuteur vivant qui ombrage cette liane et lui permet d'être vigoureuse tout en la soutenant. P. Humbert conseille de planter des tuteurs à 2m sur 2m, soit 2.500 tuteurs à l'hectare.

### La vanille (annexe III, fig. 6)

Les zones de grande production se situent dans la région d'Antalaha: Antalaha, Sambava, Andapa, Vohimarina; et dans la région de Toamasina: Maroantsetra, Mananara, Sainte-Maire, Soanierana-Ivongo, Fénériver-Est, Vavatenina.

Les zones de petite production se rencontrent dans la région d'Antseranana: Nosy Be, Ambanja, Ambilobe. La période de récolte a lieu de mai à novembre.

Les statistiques de production, de vente et d'exportations fournies par le Bureau et Caisse de Stabilisation des Prix du Café, de la Vanille et du Girofle, se résument dans le tableau suivant:

Années	Productions (vrac) en tonnes	Prix du kg aux productions	Vente en millions de Fmg	Exportations (tonnes)	Valeur FOB en millions de Fmg	% de la production exportée (poids)
1970	1 330	150	199,5	1 214	3 586	91,28
1971	1 508	220	331,8	1 159	3 565	76,86
1972	1 490	220	327,8	1 055	3 337	70,80
1973	660	220	145,2	719	2 114	108,9
1974	800	240	192	1 295	4 265	161,88
1975	1 426	250	356,5	858	2 966	60,17
1976	866	250	216,5	1 101	4 733	127,14
1977	550	280	154	1 713	8 751	311,45
1978	250	330	82,5	1 409	8 675	563,6
1979	800	500	400	427	3 002	53,38
1980	1 128	600	676,8	424	3 918	37,59
1981		700		654	7 961	

NB: Les chiffres d'exportation supérieurs à ceux de la production comprennent partiellement le stock des années précédentes.

Avant de cultiver le vanillier (g. Vanilla), il faut d'abord planter le tuteur. Quand le vanillier grandira, il faut l'enrouler autour des branches du tuteur afin de ne pas le laisser traîner sur le sol.

#### Statistiques sur les engrais chimiques et les pesticides

Pas de données, mais le vanillier exige de la fumure organique (fumier, compost, engrais vert, etc.) et de la fumure minérale (sulfate d'ammoniaque, chaux, etc).

#### Techniques traditionnelles

Au moment de la floraison, comme la structure spéciale de la fleur de l'orchidée qu'est le vanillier empêche la fécondation, l'homme intervient pour l'assurer.

#### Le café

On cultive le caféier (Coffea robusta) sur la côte Est de Vohimarina à Vangaindrano, Sambirano, Nosy Be (annexe III, fig. 1).

#### Statistiques de la production, de la vente et de l'exportation

Les chiffres indiqués ci-dessous concernent la production et l'exportation totales de différentes espèces.

Campagnes en tonnes	Production en tonnes	Prix du kg aux producteurs en Fmg	Vente en millions Fmg	Quantité en tonnes	Valeur FOB en millions Fmg	% de la production exportée en poids
1970/71	70 300	105	7 381,5	53 198	11 490	75,67
1971/72	47 200	135	6 372	57 269	11 146	121,33
1972/73	57 200	135	7 722	57 424	11 606	100,39
1973/74	65 400	135	8 829	69 479	15 321	106,23
1974/75	64 500	165	10 642,5	59 180	12 096	91,75
1975/76	65 000	165	10 725	70 453	19 409	108,39
1976/77	50 000	165/170	8 250	51 325	37 116	102,65
1977/78	71 250	180	12 825	62 229	45 198	87,34
1978/79	58 500	180	10 530	49 290	27 594	84,26
1979/80	69 500	185	12 857,5	66 045	45 562	95,03
1980/81	64 688	215	13 907,9	59 293	31 720	91,66
1981/82	58 514	250	14 628,5	50 516	27 840	86,33

Source: Bureau et Caisse de Commercialisation et de Stabilisation des Prix du Café, de la Vanille et du Girofle.

Le caféier, plante pérenne pouvant vivre 40 ans, se cultive par bouture en utilisant les rameaux orthotropes, par arcure ou marcottage, ou par semis. Dans tous les cas, le jeune caféier a besoin d'ombrage et on l'associe à d'autres plantes en général des légumineuses. Sur la côte, la plantation de caféier occupe environ 180 000 ha.

#### Techniques traditionnelles

La récolte se fait à la main cerise par cerise. Les cerises sont placées sur des nattes en couche de 4 à 5 cm d'épaisseur et elles sont remuées plusieurs fois par jour. On les laisse sécher ainsi pendant trois semaines. Les cerises sèches sont décortiquées au pilon ou dans des décortiqueuses.

Palmiers à huile (g. Elaeis)

Ils se cultivent de Sambava et dans la région de Toamasina jusqu' à Manakara (annexe III, fig. 7).

Le palmier à huile se multiplie uniquement par graines que l'on met à germer dans des caissettes. Après trois à quatre mois, les graines germées sont placées tous les 10cm dans une pré-pépinière, pendant quatre à six mois. Les plantules sont par la suite transplantées dans une pépinière et repiquées tous les 80cm où elles resteront 12 mois. Sur l'emplacement définitif, les futurs palmiers sont espacés tous les 9 mètres. A quatre ans le palmier porte des régimes intéressants et vers 10 - 12 ans, le rendement atteint environ 15 tonnes à l'hectare.

Statistiques sur les engrais chimiques et les pesticides

Nous n'avons pas obtenu de données précises. La liste ci-après concerne les achats effectués par la Société SAMBAVA VOANIO chez un importateur.

Nature des produits chimiques	1979	1980	1982
<b>Pesticides herbicides:</b>			
Lindapoudre 1,3 %	2 000 kg		
Lindapoudre 25	500 kg		
Drifène AP/EC	1 000 l	1 000 l	
Amitril T1	180 l	180 l	
Round Up	160 l	150 l	
2.4.5-T	1 000 kg		
Ethyl parathion			1 000 l
<b>Engrais:</b>			
Chlorure de potasse	1 000 t		1 200 t
Phosphate bicalcique	450 t		850 t
Superphosphate simple	130 t		
Kiesérite	220 t		

Source: Vente de la Société d'Engrais et Produits chimiques de Madagascar

Techniques traditionnelles

Les régimes cueillis depuis 48 heures sont travaillés à la machette pour détacher les fruits qui seront placés pendant 20 minutes dans un fût de 200 l contenant de l'eau bouillante. Les fruits ébouillantés sont pressés au moyen d'une presse rustique. Par chauffage de l'extrait de presse, on récupère l'huile de palme.

Riz

Sa culture se fait surtout sur les hauts plateaux, mais elle se fait dans les zones côtières à Marovoay, Bas Mangoky (Morondava), Bas Fiherenana (Toliary) et Ambilobe (région d'Antseranana). (Certaines Sociétés cependant n'ont pas daigné répondre à nos lettres et les statistiques ne peuvent être fournies). Pour ces quatre régions côtières productrices de riz, le Service de la Protection des Végétaux du Ministère de la Production agricole et de la Réforme agraire (MPARA) signale que la consommation annuelle de pesticides pour la lutte contre les poux de riz *Hispa gestroi* et *Trichispa sericea* est de 450 tonnes de dioxacarbe (carbamate) et 300 tonnes de hinosan.

### Sisal

Quelques sociétés étrangères entreprennent la culture de cette plante dans la région d'Amboasary-Sud et de Morondava (annexe III, fig. 8). Le défibrage des feuilles produirait des eaux usées corrosives à la peau.

### Protection des végétaux

Les criquets *Locusta migratoria*, *Nomadacris septa fasciata* constituent des fléaux de la végétation. L'Etat lui-même, par le Service de la Protection des Végétaux (MPARA) entreprend la lutte antiacridienne dans tout le pays. Les aires de reproduction sont localisées sur une bande côtière de 50 km de large située dans la région Sud entre Ambovombe et Befandriana-Sud (Morombe). Mais les régions à protéger s'étendent vers la côte Ouest et vers la partie Nord-Est jusqu'à Vohimarina. La lutte par les pesticides organo-chlorés ou organo-phosphorés se résume dans le tableau suivant:

Service utilisateur	Cultures	Lieux de traitement	Nature des pesticides utilisés	Base du produit	Quantité utilisée par an	Méthode de traitement	
Service de protection des Végétaux 1980/81	a) végétation contre <u>Locusta migratoria</u>	-Sud	Dieldrin 5% ULV	organochloré	7 460 l	pulvérisation	
			Dieldrin 12,5% ULV	"-	38 710 l		
		-Sud-ouest	Dieldrin 20% ULV	"-	15 530 l		
		-Ouest	Fenitrothion 3%	organo-phosphoré	5 921 kg	poudrage	
		167 966 ha	Fenitrothion 1000 ULV	"-	11 300	pulvérisation	
			Dichlorvos ULV	"-	5 280 l	"-	
			Diazinon ULV	"-	4 525 l	"-	
			Propoxur 3%	"-	32 820 kg	poudrage	
		b) végétation contre <u>Nomadacris</u>	12 405 ha	Dieldrin 12,5% ULV	organo-chloré	872 50 l	pulvérisation
				Propoxur 3%	organo-phosphoré	34 935 kg	poudrage
			HCH 25		12 900 kg	poudrage	
			Sumithion 3% (Fenitrothion 3%)		965 kg	poudrage	

Source: Service de Protection des Végétaux de Toliary et d'Antananarivo

NB: La prolifération des criquets dans leurs foyers de reproduction est fonction des conditions écologiques, en particulier des conditions météorologiques (température, pluviosité, humidité atmosphérique, etc.) La négligence dans la surveillance de ces conditions ainsi que l'insuffisance des moyens pour les combattre entraîneraient de graves catastrophes pour la population.



### Description de l'élevage

L'élevage comprend celui des bovins, des porcins, des ovins, des caprins et des volailles.

En général l'élevage traditionnel est un élevage extensif qui utilise le pâturage naturel (bovins, caprins) comme alimentation. Le bétail n'est parqué que rarement. Les porcs se nourrissent de tout ce qu'ils rencontrent, et à la côte ils contribuent au nettoyage des plages. Dans le possible, on nourrit ces animaux de produits locaux: maïs, sons de riz ou de maïs, manioc, pois de cap avariés, charençonnés, ainsi que de résidus alimentaires;

Dans l'élevage extensif des zébus sur la côte Ouest, les paysans brûlent la prairie ou les savanes surtout en hiver pour renouveler les pâturages. Ainsi entre Antananarivo et Mahajanga plusieurs milliers de kilomètres carrés de savanes en feu étaient observés, en août 1983, de pareils cas de feux de brousse se rencontraient ce même mois en pleines forêts entre Fianarantsoa et la capitale. Mais ces brûlis ne se remarquent que très rarement sur la côte orientale où la végétation est verdoyante toute l'année à cause du climat humide.

Un aspect de cet élevage en 1981 est représenté par le tableau suivant:

L'élevage dans la zone côtière

1 9 8 1	Bovins	Porcins	Ovins	Caprins	Volailles
Antseranana	65 000	-	-	-	-
Nosy Be	150 000	10 000	-	3 500	300 000
Antalaha	9 000	2 700	80	170	80 000
Andapa	12 000	13 000	-	-	500 000
Sambava	15 000	4 500	-	30	200 000
Vohémar	195 000	140	-	250	210 000
Anaalava	92 000	350	300	3 500	225 000
Maintirano	121 930	1 870	-	4 450	85 000
Soalala	125 000	10	10	200	7 000
Mahajanga	51 960	12 280	50	1 355	-
Toamasina	16 824	4 573	30	13	680 000
Brickaville	26 634	1 183	-	-	400 000
Mahanoro	15 081	10 930	-	-	270 000
Vatomandry	15 458	2 600	-	-	170 000
Fénérive-Est	11 046	1 055	-	-	153 000
Mananara-Nord	6 612	1 680	-	40	116 500
Maroantsetra	20 119	1 646	-	98	221 000
Sainte Marie	681	58	-	-	24 700
Mananjary	27 000	5 000	-	-	175 000
Nosy Varika	12 500	25 000	-	-	150 000
Farafangana	60 000	7 200	40	60	37 400
Vangaindrano	53 000	10 000	-	-	49 000
Manakara	35 000	600	25	-	200 000
Vohipeno	30 000	600	-	-	170 000
Morondava	24 681	4 126	347	6 147	9 755
Toliary	46 000	4 000	6 400	21 500	60 000
Morombe	75 000	7 000	6 000	12 500	170 000
Tolagnaro	62 873	3 180	1 382	77	375 600
<b>Total (côtes)</b>	<b>1 375 399</b>	<b>135 281</b>	<b>14 664</b>	<b>53 890</b>	<b>4 838 855</b>
<b>Total (pays)</b>	<b>7 361 140</b>	<b>655 283</b>	<b>654 350</b>	<b>1 342 463</b>	<b>16 516 368</b>
% de la pro- duction totale	18,68	20,64	2,24	4,01	29,3

Source: Direction de la Production Animale Antananarivo

De ce tableau, il ressort que l'élevage des volailles reste important mais il est consacré à la consommation locale. Celui des bovins vient à la seconde place. Ils sont élevés surtout pour leur force (travaux de labour, de transport en les attelant aux charrettes), rarement pour leur chair. Certaines tribus des régions côtières (Sud) aiment faire l'élevage contemplatif, se contentant de voir croître le nombre de leur bétail pour "l'honneur de son enterrement futur". Celui des porcins se voit limité par les interdits de la région islamique qui est pratiquée surtout sur la côte Ouest. Les caprins constituent l'élevage des petits paysans: faciles à élever ils s'adaptent aux conditions difficiles de la végétation. Le Service de la Production Animale (service de l'Élevage) grâce à ses techniciens, conseille les éleveurs pour les soins à prendre (vaccination, douchage).

### Part de l'exportation

Seule une partie des bovidés fait l'objet d'une exportation sous forme de viande congelée. L'Abattoir frigorifique National de Mahajanga a tué pendant ses quatre premières années de fonctionnement, de 1979 à 1982, respectivement 15.550, 17.203, 11.260 et 10.462 têtes de bovidés. Les 85 pour cent de cette production abattue sont exportés par la ferme d'Etat FA.FI.FA.MA (Fampandrosoana Fiompiana Faritra Andrefan'i Madagasikara ou littéralement Développement de l'Élevage dans l'ouest de Madagascar) sous forme de viande congelée.

### Disparition d'aires de reproduction du fait de leur exploitation

Quelque 200 000 ha de forêts disparaissent par an du fait des défrichements pour pratiquer des cultures itinérantes, et plus de 1 000 000 ha de prairie, du fait des feux de brousse.

### Techniques traditionnelles utilisées dans l'agriculture et dans l'élevage

Les techniques utilisées sont les suivants:

- pour les cultures itinérantes: abattage des forêts à la hache puis incendie, ensuite cultures de riz ou de maïs par poquets; et enfin abandon pour d'autres parcelles après une ou deux campagnes dès que le sol est épuisé;
- pour l'élevage extensif: on brûle la prairie pour renouveler les pâturages.

## PECHES

### Statistiques de production

En termes de pêche, le terme d'espèces ne peut être conçu. Les services responsables du contrôle des produits aquatiques se contenteraient dans leurs statistiques du nom des groupes: poissons, crevettes, crabes etc., sauf exceptionnellement. Toutefois, nous reproduisons ici le tableau publié par le Ministère de la Production Agricole et de la Réforme Agraire, (MPARA) sur la production animale.

	Unité	1970	1979	1980	1981 (Provisoire)
Poissons eau douce	tonne	35 250	35 000	40 000	40 990
Poissons marins	"	6 370	9 080	16 520	16 600
Crevettes	"	4 860	2 190	2 630	2 710
Crabes	"	200	330	485	530

Source: Annuaire 1980. Statistiques Agricoles (MPARA)

Pour la pêche crevettière et la pêche thonière le CNRO (Centre National de Recherches Océanographiques) a fourni les statistiques suivantes:

(a) Pêche crevettière

Année	Captures (tonnes)	Effort (heures)	Bateaux au 31/12
1967	775	11 360	7
1968	1 340	17 100	7
1969	1 635	16 710	6
1970	2 910	35 810	19
1971	4 080	78 640	32
1972	4 690	140 250	38
1973	4 800	144 420	40
1974	4 450	175 050	45
1975	4 630	126 850	36
1976	4 540	111 150	35
1977	5 125	106 690	35
1978	4 950	117 419	40
1979	4 330	115 668	40
1980	4 910	-	42

(b) Pêche thonière

La COMANIP a collecté : 1974 = 11 183t  
1977 = 1 600t

Chiffre estimatif de la population vivant exclusivement ou en partie de cette activité.

A. Ralison et R. Aubray ont reproduit le tableau suivant: Pêche piroguière de 1969 à 1971. (Source: Collart : 1972)

Faritany	Nombre de pêcheurs	Nombre de pirogues	Production annuelle (tonnes)
Antseranana	1 198	952	1 773
Toamasina	602	406	430
Toliary	2 837	1 914	2 996
Mahajanga	552	381	649
Fianarantsoa	633	182	518
TOTAL	5 822	3 843	6 366

Ils ont fait remarquer que les chiffres pour Toamasina et Mahajanga n'ont pas été réactualisés lors de l'établissement du tableau. Le nombre de 1971 pêcheurs, soit 0,13 pour cent de la population (Doc. DIV/PM-SPA/juillet 1980: Etude de la possibilité de la mise en place d'unités de stockage et de transformation des produits marins dans le Faritany de Toamasina) et de 1 171 pêcheurs, soit 0,10 pour cent de la population pour Mahajanga (Doc. DIV/PM/mai 1981: Amélioration du circuit de Commercialisation des Produits marins dans le Faritany de Mahajanga et collecte des Poissons d'accompagnement capturée par les sociétés crevettières) peuvent être retenus.

## Les méthodes artisanales et les méthodes industrielles

### Méthode artisanale

La pêche est pratiquée par des nationaux avec comme moyen navigant, la pirogue monoxyle avec ou sans balancier et qui est mue à la pagaie ou à la voile. On peut également rencontrer de petites embarcations motorisées de moins de 25 CV. Des privés se livrent au chalutage crevettier avec des bateaux améliorés de type FAO ou à la pêche à la palangrotte sur les hauts-fonds récifaux. Encouragés par l'administration malgache avec subventions et dons en équipements, les pêcheurs artisanaux se regroupent actuellement et il existe:

- des précoopératives de pêche;
- des coopératives socialistes de pêche;
- des associations ou unions de pêche;
- des coopératives de commercialisation des produits marins.

L'objectif à atteindre est de réaliser la mutation de la pêche piroguière en pêche artisanale motorisée pour augmenter le rendement.

### Méthode industrielle

L'exploitation industrielle des ressources crevettières, thonières, et des petits poissons pélagiques utilise de grandes embarcations motorisées, bien équipées. A terre, les entreprises disposent de chambres froides, de congélateurs, de tours à glace, de calibreuses; en outre, elles possèdent des bureaux, des ateliers divers (bois, électricité, mécanique, froid etc.) de magasins, de commodités (logements etc.) pour leurs cadres.

### Industries alimentaires

Il n'existe pas encore d'industries de conserves utilisant des produits de la pêche à Madagascar. SOMAPECHE et SOPEBO de Mahajanga, PNB de Nosy Be s'occupent de l'étêtage, de la congélation, du conditionnement et de l'exportation des crevettes.

### Les pratiques de commercialisation

Dans la pêche industrielle, les sociétés crevettières rejettent en mer des quantités importantes de poissons capturés avec les crevettes à chaque trait de chalut à cause de l'insuffisance de place dans la cale de stockage. Il n'y a que les poissons de qualité qui sont ramenés à terre pour être livrés à la consommation humaine. D'autre part, après calibrage, étêtage des crevettes, les têtes sont également jetés en mer. A. Ralison pense qu'avec 5 000t/an de crevettes produites, on peut avoir 1 075 tonnes de têtes de crevettes; ce qui donne environ 560 tonnes de farine après dessiccation et broyage. Il avance par la suite que Madagascar n'aurait jamais importé soit de farine de tête de crevette, soit de concentrés protéiniques pour l'alimentation des animaux si les têtes de crevettes ainsi obtenues n'étaient pas rejetées en mer tel qu'il fut le cas jusqu'ici à Nosy Be.

Le tableau suivant sur la distribution de la pêche maritime pour la consommation humaine donne une vue d'ensemble de la production de la pêche en mer:

Année	1966	1969	1972	1975	1978
Autoconsommation	4 200	3 900	3 600	3 000	3 500
Commercialisation sur les marchés côtiers	1 500	1 400	1 000	2 500	2 800
Commercialisation sur les marchés intérieurs	700	600	800	1 500	1 700
Exportation	600	2 000	3 400	7 500	3 500
Production totale	7 000	7 900	8 800	14 500	11 500

Source: Documents et Estimation du Service de la Production Animale

#### Part des produits de la pêche dans l'alimentation

Année	Population million	Produits disponibles (millions de tonnes)		Disponibilité en kg de protéines/tête/an	Consommation/tête/an en kg de produits marins
		Viande	Poissons de mer d'eau douce		
1966	6,7	122,6	6,4	24,27	0,96
1969	7,4	122,8	5,9	22,09	0,80
1972	7,5	112,5	5,4	20,64	0,72
1975	8,0	115,2	7,0	20,21	0,87
1978	8,5	122,4	8,0	19,98	0,94

Source: Documents du DIV/PM. Mai 1981 Sce des Pêches Maritimes

NB : (i) disponibilités en produits d'élevage et en poissons; (ii) les chiffres les chiffres correspondant aux poissons d'eau douce dans le tableau ont été tirés du Plan de Développement et d'Encadrement des Pêches Continentales et de l'Agriculture de 1980 à l'an 2000. Document MAG/76/002.7

Les disponibilités en viande (bovins, porcins, ovins, avicole etc.) et en produits ichtyologiques (marins et d'eau douce) n'arrivent plus à faire face aux besoins de la population. Il est à craindre que le seuil de carence protéinique (20kg/tête/an) au-delà duquel apparaissent les maladies nutritionnelles ne soit rapidement atteint s'il ne l'est déjà. A. Ralison et R. Aubray estiment à 6,2 kg par capita la disponibilité en poisson à Madagascar. Elle est très inférieure à celle existante en de nombreux pays. Ils évaluent à 55 000t la quantité de poisson consommée annuellement à Madagascar. La pêche côtière traditionnelle consommée localement n'atteint que 8 000t de poissons de mer, le complément est donc fourni par la pêche continentale. Pourtant, d'après les travaux d'expert sous l'égide de la FAO, signalés par A. Ralison et R. Aubray, les eaux côtières malgaches recèleraient 40 000t de poissons démersaux et de 50 000 à 100 000t de petits poissons pélagiques.

#### Les flottes qui pêchent dans la zone économique nationale

De nombreuses sociétés s'intéressent à la pêche industrielle et possèdent des embarcations plus ou moins importantes.

#### La pêche crevettière

Elle est très importante car elle contribue à la rentrée de devises pouvant atteindre 4 Milliards de Fmg. Quatre sociétés étaient en activité en décembre 1982:

- la Société des Pêcheries de Nosy Be (PNB) qui fonctionne depuis 1976;
- la Société Malgache de Pêche (SOMAPECHE) qui est basée à Mahajanga et fonctionne depuis 1967;
- la Société de Pêche du Boina (SOPEBO) qui provient de la conversion en novembre 1982 de l'ex-FAMAKO créée à Mahajanga en 1974;
- la Société REFRIGEPÊCHE qui exploite depuis 1981 un seul chalutier à Toamasina.

#### La pêche thonière

Seule la Compagnie Malgache Nipponne de Pêche (COMANIP) exploitait le thon à partir de Nosy Be avec neuf navires canneurs de 38m/200 gt (1973-1975). En 1977, 1 600t de thons majeurs furent capturés dans les eaux malgaches par des palangriers asiatiques.

#### La pêche des petits poissons pélagiques

MANIVICO (Société Malgache Nipponne de Viande Concentrée) a effectué dans la baie d'Antseranana des essais de pêche aux petits poissons pélagiques à l'aide des filets fixes d'origine japonaise.

#### La pêche aux langoustes

Elle se pratique dans la région de Tolagnaro jusqu'à Faux-Cap, Androka. Elle est actuellement entre les mains de la "L.A.N.S.U" qui produit 40 à 50 tonnes par an.

#### Réglementation sanitaire applicable aux produits de la pêche

Le Service de la Pêche Maritime s'occupe du contrôle de l'état de salubrité des produits en vente au marché intérieur, ou destinés à l'exportation. Pour la pêche continentale il n'y a aucun contrôle.

PROSPECTION ET EXPLOITATION DES RESSOURCES MINERALES  
(Y COMPRIS LES HYDROCARBURES ET LE SABLE)

Hydrocarbures

L'office Militaire National pour les Industries Stratégiques a le monopole de la recherche et de l'exploitation des minerais ayant un intérêt "stratégique" (hydrocarbures, minerais radioactifs, etc.) Actuellement, au point de vue de la prospection pétrolière, trois compagnies pétrolières étrangères effectuent des opérations sur le littoral malagasy. Il n'y a donc pas encore ni production, ni vente ni exportation.

Compagnie	Permis	Situation des travaux en juin, 1983
A G I P	Majunga - onshore et offshore sur 22 400km <sup>2</sup>	Démarrage des travaux sismiques terrestres
M O B I L	Morondava - offshore sur 36 000 km <sup>2</sup>	- sismique marine 1 280km - 3 870km en cours de réalisation
A M O C O	Bemaraha onshore sur 22 500 km <sup>2</sup>	- layons ouverts dans le bloc Sud Serinam 145km - aéromagnétisme : 15 000km

Sable

A Toamasina, la SOVEMA ou Société Verrerie de Madagascar utilise le sable blanc siliceux plus ou moins grénatifère pour la fabrication des verres creux (cf. Développement industriel du littoral).

Coraux

Ces Coraux font l'objet d'une exploitation dans la région de Toliary, Toamasina, par des entreprises privées de bâtiments. Le tonnage n'est jamais évalué car aucun service public n'en fait le contrôle.

TOURISME

Madagascar est divisé en cinq régions touristiques dont quatre touchent le littoral. Ces dernières ne correspondent pas aux divisions provinciales (cf carte no 6). Elles sont réparties comme suit:

- la région II ou Côte des Iles Vierges englobant Nosy Be et les villes de Mahajanga et d'Antseranana;
- la région III ou Côte du Capricorne regroupant Morondava et Toliary;
- la région IV ou Côte des Epices avec Tolagnaro et Mananjary ainsi que Manakara;
- la région V ou Côte du Palissandre avec l'ilôt Sainte-Marie et les villes de Toamasina et de Mahavelona (Foulpointe).



Ces îles et différentes villes côtières possèdent un centre hôtelier de classe internationale et aussi du type "ravinala" c'est-à-dire des hôtels modestes classés de 1 à 3 R.

### Nombre d'hôtels sur le littoral

Il existe 37 hôtels à étoiles sur les côtes et 37 hôtels du type ravinala soit au total, 74 hôtels pour tout le littoral malgache (voir tableau no 9 de l'annexe II).

### Nombre de touristes chaque année (Source: Direction du Tourisme)

Les renseignements obtenus auprès de la Direction du tourisme ne permettent pas de classer les touristes visitant les côtes ou y séjournant ni de les répartir dans les différentes villes hôtes. Les villes les plus visitées ne sont pas non plus citées. Toutefois l'évolution du nombre des visiteurs internationaux arrivés aux frontières de 1978 à 1982 est indiquée dans le tableau no 10, de l'annexe II. Ces mêmes données se reflètent sur le graphique ci-dessous:

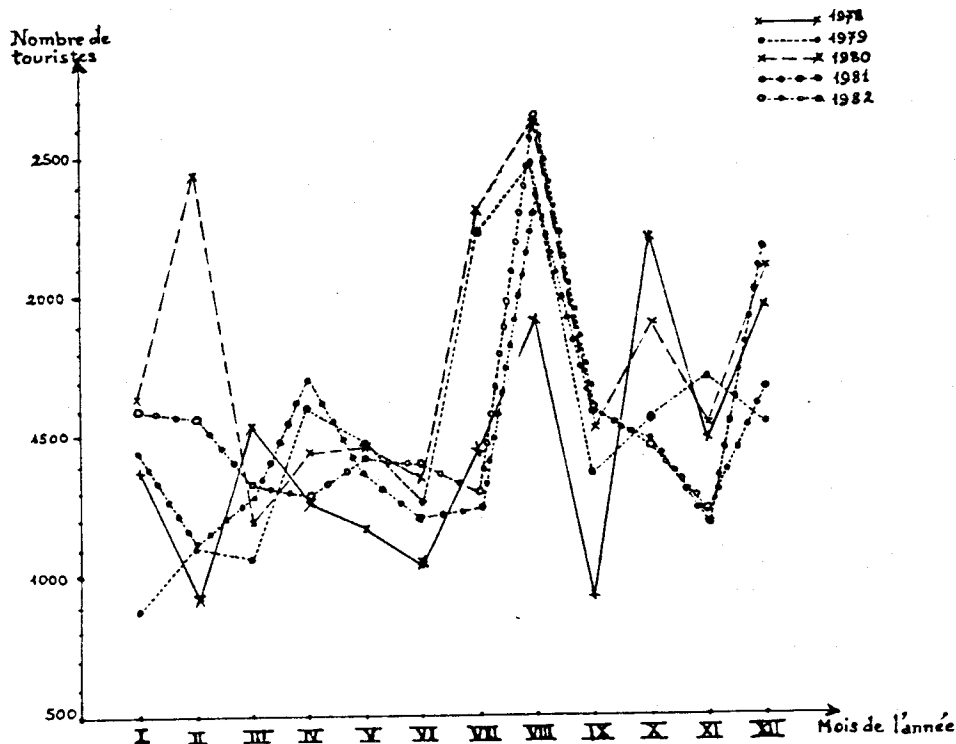

EVOLUTION DES ARRIVEES DES VISITEURS INTERNATIONAUX  
AUX FRONTIERES de 1978 à 1982

Ce tableau et ce graphique montrent que le nombre de visiteurs étrangers est encore assez faible par rapport à celui des autres pays riverains d'Afrique. Cependant, il faut noter que pendant neuf mois sur douze, le nombre de touristes varie de 1 000 à 2 000; les périodes d'affluence correspondant aux vacances se situent aux mois de juillet, août et décembre. Le tableau no 11, annexe II, montre cependant, que si l'on observe le nombre de touristes passant dans quatre hôtels de confort des quatre villes côtières, l'île de Nosy Be présente un effectif qui vaut le triple du nombre des visiteurs des trois autres régions Mahajanga, Toliary, Toamasina. Si l'on applique le tarif actuel de 12 000 Fmg en moyenne aux effectifs rencontrés en 1980 et 1981 dans chacun de ces hôtels, l'on constate pour ces quatre hôtels une rentrée de devises s'élevant à 115 millions de Fmg en 1980 et à 100 millions en 1981 (tableau no 12, annexe II).

### Recettes annuelles

A titre indicatif, les recettes en devises de tout Madagascar provenant uniquement des changes effectués par les visiteurs internationaux atteignent:

A n n é e	1976	1977	1978	1979	1980
Chiffres en millions Fmg	770	612	694	1 064	1 063

Source: Banque Centrale de la République Démocratique de Madagascar

### Incidences du tourisme sur les écosystèmes

Quelquefois, en voulant favoriser le tourisme, on s'efforce de détruire la beauté de la nature, celle d'un site par exemple, par une tentative d'innovation très artificielle (installation de bancs, de tablettes de ciment).

Le ramassage massif d'animaux dans un but lucratif (ex: coquillages, étoiles de mer, madréporaires appelés vulgairement coraux, etc) entraînerait un déséquilibre biologique de l'écosystème récifal qui peut occasionner de graves conséquences. Telle l'histoire de la destruction du Récif de la Grande Barrière d'Australie due à la prolifération de l'étoile de mer *Acanthaster planci* à la suite de la collecte excessive par l'homme du gastéropode *Charonia tritonis* prédateur de larves de cette étoile.

La disparition de certaines espèces de Poissons comme les mérous chassés par les plongeurs épris de chasse sous-marine est à craindre dans un temps à venir.

Enfin, la vente des langoustes pendant la période de frai (novembre-décembre), pour satisfaire les clients (touristes sur place ou aussi les exportations) engendrerait également des effets néfastes pour ce groupe de crustacés.

### CONCLUSIONS

Ce rapport présente beaucoup de lacunes par suite de l'insuffisance des renseignements obtenus : certaines sociétés privées n'ont pas daigné répondre, d'autres n'ont pu encore mettre à jour leurs statistiques au moment de notre demande, bien que les déplacements à travers l'île aient été effectués. Toutefois, quelques conclusions tirées des enquêtes pourraient servir de base de travail pour le développement économique du pays et la protection du capital biologique.

Grâce à sa situation sous le Tropique, ses 4 000 km de côtes, ses nombreuses lagunes, ses immenses mangroves, ses récifs d'une longueur non négligeable de plus de 1 000 km, ses biotopes côtiers variés permettant à diverses espèces d'y proliférer, Madagascar offre sur la côte des possibilités d'exploitation fort promettantes, tant au point de vue pêche, élevage, agriculture, industrie que de tourisme. Les divers tableaux donnés dans ce rapport, bien qu'incomplets, reflètent les efforts déjà déployés dans diverses branches.

En jetant un coup d'oeil sur la répartition des zones côtières (cf annexe III), nous remarquons que des cultures industrielles, sources de devises pour le pays, telles que vanille, girofle, café, canne à sucre, coton, palmier à huile, sisal, y sont comprises. Il est donc tout à fait normal que des industries de transformation

s'implantent sur place. Ceci entraîne un appel de main-d'oeuvre, c'est-à-dire une agglomération importante sur la côte, pouvant engendrer une augmentation des déchets si les installations médicales et sanitaires ne sont pas suffisantes. D'autre part, l'amélioration des cultures et leur extension, nécessitent l'utilisation des engrais et de divers pesticides. Le développement industriel sous entend le rejet d'eaux usées dans l'environnement immédiat. Les touristes, attirés par la beauté des sites côtiers, remplissent les hôtels qui déversent leurs déchets dans la mer. Tous les déchets directement déposés sur la plage ou les eaux usées véhiculées par des rivières, regagnent la mer qui va se polluer de plus en plus. Les acides, les bases, les sels (cyanures) et les métaux lourds (mercure, plomb) provenant des usines, pourraient constituer de véritables poisons qui anéantiraient des espèces sensibles à ces éléments.

La recrudescence de la population va aussi intensifier la pêche. Si cette dernière n'est pas réglementée, nous courrons le risque de perdre un capital précieux. Pour protéger la nature, il ne faut pas perdre de vue deux points très importants : la multiplication de ce capital et sa conservation.

Le premier point suppose pour les êtres aquatiques des essais de culture et d'élevage.

Le second demande différentes mesures à prendre: vis-à-vis de la population, une éducation aussi bien à l'école que dans les villages (fokontany), un enseignement plus complet sur les écosystèmes des zones côtières (littoral, récifs, mangroves, lagunes, côtes ...), une conscientisation contre le feu de brousse, contre les pollutions diverses et ceci par des moyens audio-visuels variés : panneaux au bord de la mer, au bord des forêts, émissions radiophoniques, télévisées, etc.

Des mesures de protection peuvent concerner aussi bien les espèces végétales qu'animales, côtières que franchement marines. Les décrets datant de la période coloniale méritent des révisions au sujet des périodes de pêche (ex: langoustes), des mailles de filet, des tailles limites capturables (ex: holothuries ou trépangs), etc. Des contrôles de eaux usées devraient être de temps en temps entreprises pour prévenir de fâcheuses conséquences.

Consciente de différents dangers qui menacent la nature, ainsi que la surexploitation, la Station Marine de Tuléar a pris ces dernières années des initiatives de recherche déjà commencées par Rabesandratana, sur celle des holothuries les plus exploitées (*Holothuria scabra*, *Holothuria tubulosa*, *Thelenota ananas*), sur des essais de culture d'algue du genre *Eucheuma* (déjà mis en place). Les essais de méthanisation des algues marines donnant des résultats encourageants pourraient peut-être résoudre partiellement le problème d'énergie (combustibles) et éviter ainsi les feux de brousse de la zone côtière ainsi que le déboisement des mangroves.

Dans le cadre de l'enseignement, depuis 1981, des cours d'Océanologie Appliquée sont dispensés à l'E.E.S. Sciences de Tuléar et les recherches effectuées à la Station Marine de Tuléar. Il est souhaitable que des cours de Molysmologie soient assurés par des spécialistes. Tous les travaux de recherche en cours et ceux indispensables à développer la lutte contre la pollution comme l'analyse des eaux marines et même continentales (ex: eaux usées) nécessitent obligatoirement du matériel de recherche.

Enfin le récif, particulièrement important grâce aux espèces qu'il abrite, exige avant tout des eaux claires, et un équilibre biologique bien déterminé. La proposition de la Station Marine de Tuléar de faire du grand récif de Tuléar un parc national, devrait être considéré sérieusement.

BIBLIOGRAPHIE

- Anonyme (1973) Etude portuaire sur la côte Nord-Ouest de Madagascar et à Maroantsetra vol. IX Hydrographie, Océanographie, Sédimentologie, Météorologie. IX A. Port de Majunga. Rapport du L.C.H.F. (Laboratoire Central Hydraulique de France)
- Anonyme (1980) Etude de la possibilité de la mise en place d'unités de stockage et de transformation des produits marins dans le faritany de Toamasina. Rap. Doc. Div/PM-SPA/Juil. : 18p.
- Anonyme (1980) L'Agriculture en 1980 et sa situation au seuil de 1982. Annuaire 1980. Statistiques agricoles. Suppl. au no 11 de la série. "Statistiques courantes". (See Statistique Agricole)
- Anonyme (1981) Amélioration du circuit de commercialisation des produits marins dans le faritany de Mahajanga et collecte des poissons d'accompagnement capturés par les sociétés crevettières". Doc. Div/PM/Mai : 15p.
- Battistini, R. (1964) L'extrême-Sud de Madagascar. Etude géomorphologique. Tome II : le littoral. Etudes malgaches. Lab. de géo. Univ. M/car : 636p.
- Battistini, R. (1978) Observations sur les cordons littoraux pléistocènes et holocènes de la Côte Est de Madagascar. Mad. rév. de géo. no 33 : 9-37.
- Battistini, R. (1980) Les vasques étagées, formes curieuses des estrans grésocalcaires au Sud de Madagascar". Mad. rév. de géo. no 37 : 63-86.
- Bulteau, L. (1972) La production du sucre à Madagascar/Terre malgache: 211-220.
- Collart, A. (1972) Etude socio-techno-économique de la pêche traditionnelle maritime à Madagascar. Doc. tech. MAG 15 no 18. ONU/FAO : 87p.
- Crosnier, A. (1964) Les Crevettes Pénaéides du plateau continental malgache. Etude de nos connaissances sur leur biologie et leur pêche en septembre 1964. Doc. no 271 - S.R. Océanographie. Centre ORSTOM ORSTOM de Pointe - Noire : 142p.
- Donque, G. (1974) Le climat d'une façade au vent de l'alizé: la côte Est de Madagascar. Mad. rév. de géo. no 24 : 9 - 74.
- Hubert, P. Recueil de fiches techniques d'Agriculture spéciale à l'usage des lycées agricoles de Madagascar. Tomes I & II. édit. par M.A.E.R. et B.D.P.A.
- Institut National de la Statistique et de la Recherche Economique (INSRE) (1981) La situation économique au 1er Janvier : 77p.
- Kiener, A. (1963) Poissons, pêche et pisciculture à Madagascar. Centre tech. forestier tropic. : 160p.
- Lasserre, G. (1979) Bilan de la situation des pêches aux Pangalanes-Est (Zone Tamatave Andevorante) au Lac Anony (région Fort-Dauphin). Perspective et aménagement. Rap. pour ONU/FAO pour projet MAG/76/002 : 38p.
- Rabesandratana, H.D. (1974) Gisements d'huître *Crassostrea cucullata* Born var. *cornucopiae* Chemnitz dans l'Extrême - Sud de Madagascar - Tethys, supplém. 1. Océan Indien Tropical (Stat. mar. d'Edoume): 141 - 160.

Rabesandratana, R.N. & Rabesandratana, H.D. (1970) La mangrove: fiche documentaire. Univ. de Madagascar, Tuléar. 18p. (document ronéotypé)

Ralison, A. & Auray, R. (1982) Directives pour un programme général de développement des pêches maritimes malgaches. Rap. pour projet ONU/FAO MAG/80/008: 64p.

Ranaivoarisoa, Th. (1980) Production et économies giroflières dans le fivondronana de Fénérive-Est. Mém. fin d'études Etab. Ens. Sup. Sci. agron : 138p. (ronéo.)

Rossi, G. (1974) Les divisions régionales de l'Extrême-Nord de M/car. Mad. rév. de géo., no 24, Janv.- juin : 75 - 87.

Salomon, J.N. (1980) Les récifs coralliens de Belo-sur-mer : étude géomorphologique. Mad. rév. de géo. no 37, juil. - déc : 87; 109.

Annexe I

LOCALISATION DES MANGROVES D'ESTUAIRES (à l'embouchure des fleuves et des rivières):

(a) Côte Ouest, en remontant du Sud au Nord:

Menarandra (baie de Bevoalavo), Linta, Itampolo, Onilahy (baie de Saint-Augustin), Fiherenana (N. de Toliary), baie de Lamboharana (ou baie des Assassins), Nord d'Anvadoaka et région Sud de Morombe, Bas Mangoky, Morondava, Tsiribihina, Manambolo, Mahavavy-Sud, région de Maintirano, Besalampy - Soalala, Mitsinjo: Betsiboka, Antanimasaja, Boanamaro, Katsepy, Boina, Amborovy, Mangatsa dans la région de Mahajanga; Tsianinkira, côte Nord-Ouest dans la baie de Mahajamba; Sofia, Loza; Antsampano, Ampepamena (région d'Ambanja); Andranomalaza Sambirano, Mahavavy-Nord, Port Saint-Louis dans la région d'Ambilobe.

(b) Côte Est:

Région d'Antseranana: en allant vers Ramena, Ambodivohibe; Vohimarina (Vohémar), Manompana (lieu de transbordement pour l'île Sainte-Marie), Ambodifotra (côte ouest de l'île Sainte-Marie), région de Lokaro, Sainte-Luce (région de Tolagnaro). (Gachet, G., Kiener, A. 1963, Rabesandratana, N.R. & H.E., 1970)

MANGROVES LITTORALES

Elles sont localisées dans les zones où il y a des résurgences d'eau douce: exemples: Nord de Sarodrano, Ankilibe, Ankiabe, Toliary, Songoritelo, etc.

Annexe II

Tableau 1: Population urbaine tributaire du littoral et des eaux côtières  
(Recensement de 1975) (INSRE)

Villes	Résidents (présents et absents)	Visiteur chez des ménages	Passager dans des centres d'hébergement <sup>a/</sup>	Population dans les ensembles particuliers <sup>b/</sup>
Fénérive-Est	10 823	380	65	48
Maroantsetra	11 725	173	52	261
Toamasina	77 395	1 460	520	1 179
Mahanoro	3 889	96	60	45
Vatomandry	5 136	225	44	239
Mananjary	15 134	195	72	172
Farafangana	13 652	294	114	533
Manakara	20 037	257	130	370
Vangaindrano	15 075	196	55	134
Majunga	65 864	1 557	352	1 562
Maintirano	5 387	169	68	579
Antseranana	40 443	548	94	1 355
Ambanja	11 334	134	102	290
Nosy-Be	23 396	92	80	264
Antalaha	17 029	135	106	363
Sambava	13 608	183	36	103
Vohimarina	4 635	175	18	41
Toliary	45 676	1 098	183	1 301
Morombe	5 652	98	95	492
Tolagnaro	18 270	515	95	1 084
Morondava	14 894	227	47	684

<sup>a/</sup> Centres d'hébergement: Hôtel, auberge, gîte d'étapes, maternités, hopitaux, etc.

<sup>b/</sup> Ensembles particuliers: Caserne, prison, internat, etc.

Tableau 2: Population rurale tributaire du littoral et des eaux côtières (INSRE)

Sous-préfecture rurale	Effectif de la population
Antalaha	70 636
Sambava	103 144
Vohimarina	82 298
Ambanja	49 530
Ambilobe	56 496
Diego-Suarez	38 916
Fénérive-Est	110 882
Mananara-Nord	44 851
Maroantsetra	73 513
Sainte-Marie	10 073
Soanierana-Ivongo	43 323
Vavatenina	72 665
Brickaville	72 951
Mahanoro	97 496
Toamasina	90 819
Vatomandry	81 916
Analalava	42 149
Maintirano	22 089
Besalampy	18 831
Soalala	12 279
Majunga	21 172

NB: Belo-s/Tsiribihina (urbain et rural) = 31 222

Amboasary (U et R)	= 80 813
Ambovombe (U et R)	= 72 753
Nosy-Varika (U et R)	= 102 717
Vohipeno (U et R)	= 62 030
Vangaindrano (U et R)	= 123 736



Tableau 3: Branches d'activité dans les zones côtières

Donnée: Recensement de 1975. Branche d'activité. Milieu urbain.

Source: Service Démographie. Direction de la Population.

VILLES	Secteur primaire %	Secteur secondaire %	Secteur terti- aire %	Proportion des agriculteurs par rapport à la po- pulation totale des villes (en %)	Proportion des pêcheurs par rap- port à la popu- lation totale des villes (en %)
Tamatave	1,22	6,17	20,23	0,18	0,03
Mahanoro	14,30	2,42	12,37	0,12	-
Vatomandry	6,85	2,73	18,52	0,07	0,01
Fénerive-Est	15,78	3,16	11,53	0,33	0,01
Maroantsetra	17,07	2,16	8,20	0,44	0,01
Mananjary	6,86	5,34	14,17	0,23	-
Farafangana	5,18	4,75	13,76	0,14	0,02
Manakara	3,10	7,69	14,99	0,11	0,03
Vangaindrano	37,85	1,11	4,01	1,28	-
Majunga	2,92	10,19	15,66	0,21	0,22
Maintirano	10,69	4,25	15,09	0,10	0,03
Diego-Suarez	2,56	7,48	16,70	0,21	0,01
Ambanja	12,97	5,48	11,79	0,32	-
Ambilobe	9,03	4,24	11,79	0,13	-
Nosy-Be	13,33	8,72	8,48	0,59	0,10
Antalaha	12,70	2,68	15,76	0,47	-
Sambava	25,39	2,70	11,78	0,77	-
Vohémar	3,49	4,31	15,43	0,03	-
Tuléar	2,26	4,56	17,64	0,19	0,03
Morombe	4,88	1,96	27,90	0,03	0,03
Morondava	8,41	3,43	13,03	0,23	0,04
Fort-Dauphin	2,37	6,09	16,10	0,06	0,03

NB: Les proportions par secteur sont par rapport à la population totale de la ville considérée.

- Secteur primaire : agriculture, élevage, eaux et forêts, pêche.
- Secteur secondaire: mines, diverses industries, bâtiments et travaux publics, électricité et eau.
- Secteur tertiaire : commerce, banques, assurances, transport, postes, services libéraux administratifs et privés, recherches, et restaurants.

Donnée du Ministère de la Production et de la Réforme Agraire (MPARA) - 1980

Source: Recensement général INSRE 1975. Recensement Ministère de l'Intérieur 1979

Sous-prefectures a/ ou Fivondronam -pokontany b/ côtières par Faritany	Population Insre 1975		Population Min. Inter, 1979		Population agricole 1980	Observation		
	Totale a/	Urbaine	Rurale	Totale b/ Urbaine			Rurale	
<b>F. de ANTSEANANA</b>								
Antseranana	79 359	40 443	38 916	72 498	32 453	40 045	35 995	-
Ambilobe	69 295	12 799	56 496	80 103	13 942	66 161	11 844	-
Nosy Be	23 396	23 396	0	38 718	14 429	24 289	14 116	-
Ambanja	60 864	11 334	49 530	66 591	15 619	50 972	33 063	+
Antalaha	87 665	17 029	70 636	95 831	21 819	174 012	96 789	+
Sambava	116 752	13 608	103 144	115 248	7 521	107 727	129 941	-
Vohimarina	86 933	4 635	82 298	121 130	4 135	116 995	16 507	-
<b>F. de TOAMASINA</b>								
Toamasina	168 214	77 395	90 819	176 782	76 505	100 277	164 510	-
Brickaville	72 951	-	72 951	72 733	1 878	70 855	70 909	+
Vatomandry	87 052	5 136	81 916	70 342	5 033	65 309	68 504	+
Mahanoro	101 385	3 889	97 496	102 395	5 281	97 114	108 698	+
Fénétrive-Est	121 705	10 823	110 882	120 542	10 133	110 409	122 556	-
Maroantsetra	85 238	11 725	73 513	92 592	13 149	79 443	87 781	+
Mananara Nord	44 851	-	44 851	63 885	18 163	45 722	64 135	+
Vavatenina	72 665	-	72 665	87 254	3 746	83 508	82 586	+
Soanierana-Ivongo	43 323	-	43 323	45 325	2 803	42 522	45 453	+
Ile Ste-Marie	10 073	-	10 073	10 644	7 103	3 541	10 770	+
<b>F. de FIANARANTSOA</b>								
Nosy Varika	102 717	-	102 717	130 616	20 920	109 696	-	+
Mananjary	139 059	15 134	123 925	162 326	15 307	147 019	173 491	-
Farafangana	127 640	13 652	113 988	163 539	15 633	147 906	160 521	-
Manakara	135 056	20 037	115 019	183 856	23 314	160 542	165 125	-
Vohipeno	62 030	-	62 030	62 080	3 100	58 580	60 958	+
Vangaindrano	123 736	15 075	108 661	143 165	15 678	127 487	133 680	-

Tableau no 4 (suite)

F. de TOLIARY		112 306	45 676	66 630	135 699	65 560	70 139	104 700	+
Toliary									
Morombe		48 092	5 652	42 440	47 004	6 747	40 257	44 173	-
Tolagnaro		98 509	18 270	80 239	93 684	19 108	74 576	43 947	+
Morondava		35 355	14 894	20 461	49 514	28 200	23 314	45 922	+
Beloha		30 223	-	30 223	32 825	-	-	-	
Belo-sur-Tsiribihana		31 222	-	31 222	42 700	4 200	38 500	40 146	+
Amboasary		80 813	-	80 813	87 471	3 315	84 156	-	+
Ambovombe		72 753	-	72 753	89 834	2 329	87 505	?	
Tsihombe		34 488	-	34 488	36 660	1 021	35 639		+
F. de MAHAJANGA									
Mahajanga		87 576	65 864	21 172	90 600	71 843	18 758	65 700	+
Marovoay		56 291	26 303	29 988	70 096	15 118	54 978	46 711	-
Analalava		42 149	-	42 149	59 674	5 100	54 574	62 611	+
Maintirano		27 476	5 387	22 089	46 780	9 800	36 980	37 614	+
Besalampy		18 831	-	18 831	-	2 853	-	32 541	
Soalala		12 279	-	12 279	11 577	4 011	7 566	13 627	+

a/ ancienne dénomination (recensement INSRE 1975)

b/ nouvelle appellation (recensement après 1975)

Tableau no 5: Principaux complexes industriels du littoral

Source: Ministère de l'Industrie et du Commerce

S.A. = Société Anonyme; S.A.R.L. = Société Anonyme à responsabilité limitée; S.E.M. = Société d'Economie Mixte; P = Privé  
 ET = ETAT; N = Nationaux; E = Etrangers; E.S. = Entreprise Socialisée; \* = % de la production totale du pays; B.N.I et  
 B.I.M. = Banques

Entreprises	Localisation	Forme juridique	Activités	Capacité de production en tonnes ou % *	Consommation locale	Exportation	Effectif du personnel (1981)
CONSALIMAD	Antseranana	S.A.P = 100% N et I	Exploitation des marais salants	35 000 t/an (1981)	80%	20%	157
SCIM	"	S.A.P = 100% Etrangers	Huilerie	500 t/an (1981)	100%		
SECREN	"	E.S	Savonnerie	3 200 t/an (1981)	100%		1 562
STAR	"	S.A	Construction, réparation navale		100%	Tourteaux	45
SNBCE	Brickaville	S.A : ET 72%, E 28%	Fabrique de bières, jus, sirops	11,4%	100%	10%	4 308
ABAITOIR AFNM	Mahajanga		Sucrerie - Distillerie	31 600 t/an (1981)	90%		
CIMALGA	"	S.A : ET 9,6%, N 4,5% E 85%	Ciment		100%		464
FITIM	"	E.S	Filature, Tissage		100%		896
HASYMA	"	S.A ET 70% CFDT 30%	Egrenage et commercialisation du coton fibre	81% (1981)	100%		539
SEIM	"	S.A.R.L.P 100% Etrangers	Huilerie - Savonnerie	400t (1981)	100%		129
SIB	"	S.A.P. 100% Etrangers	Savonnerie	8 000 t/an (1981)	100%		243
SOMAPECHE	"	S.A : N = 8,9%; Japon 48,7%; Franco-Malgache 42,4%	Huilerie	2 000 t/an (1981)	60%	40%	531
SOMIA	"	S.A.P 100%; N et E	Pêche industrielle (crevettes)				
SOPEBO	"	S.A: ET 50%, E 50%	Sisal-Cacao-Huiles Essentielles		80%	20%	1 079
SOTEMA	"	S.A.N 50,56%; E 46,21% Autres 3,23%	Pêches industrielles		80%	20%	150
CARTON ELGE	Toamasina	S.A.P 100% N et E	Filature - Tissage - Teinture		90%	10%	4 259
FANDROSOANA	"	S.A.P 100%; N et E	Impression		100%	0	95
MACOMA	"	S.A.P 100% Etrangers	Fabrication des emballages en cartons				
			Ondulation des tôles	8 000 t/an (1981)	100%	0	80
			Ondulation des tôles	9 000 t/an (1981)	100%	0	179
			Pointerie	1 200 t/an (1981)			

Tableau no 5 (suite)

1	"	S.A.P 100%; Etrangers	Fabricant d'emballages métalliques	3 000 t.	(1980)	90%	10%	220
MA	"	Société d'Etat	Raffinage des produits pétroliers	54,5%	(1981)	100%	-	1 190
ALVAL	"	S.A.P 100%; N et E	fabrication de lubrifiants	2 000 t/an	(1981)	95%	5%	89
APALM	"	S.E.M. : ET 66%, B.T.M 34%	Usine de peinture, vernis, diluants....	10 000 tonnes	(1981)	100%	0%	449
MAE	"	S.A.P N et E	Exploitation agro-industrielle de palmeraie	d'huile/an	(1981)	100%	0%	219
EMA	"	S.A.P 100%	Fabrication d'ustensiles de ménages en tôle émaillé	17 155 t/an	(1981)	90%	10%	247
ALU	"	N et E	Fabrication de verres creux					
	"	E.S	mécanique = Bouteille				0	130
EN	"	E.S	Fabricant d'articles de ménages en aluminium	90 000 t/an		100%	0	7
NJARA	Toliary	S.A.P 100% N et E	Fabrication d'engrais chimiques			100%	0	20
MA	"	S.A: ET 70%, CFDT 30%	Ondulation des tôles					
U	"	S.A: ET 20%; BNI 80%	Egrenage et commercialisation du coton fibre			100%		491
R	"	S.A	Huilerie - Savonnerie - Provenderie			100%		
ATEX	"	E.S	Fabrication de bières, jus, sirops	80%	(1981)	100%		1 057
Y	"	E.S	Filature, Tissage			100%		362
DTSY	"	S.A.P 100%	Fabrication de matériels agricoles	58%	(1981)	100%		17
ERBAY	Maintirano	S.A.R.L 100% P	Fabrication de capsules	250 t/an		100%		41
IAM	Morondava	Etrangers	Huilerie			100%		367
A	"	S.A : ET 34% E 66%	Savonnerie			100%		
AMA	Namakia (Mahajanga)	S.A.R.L.P 100%; Etrangers	Exploitation industrielle et agricole	29%	(1981)	100%	Tourteaux	28
CE	Nosy Be	Société d'Etat	Huilerie	15%	(1981)	70%	30%	5 172
OR	Tolagnaro	S.A. ET 72%; E 28% S.A.P 100%; Etrangers	Savonnerie Sucrierie Distillerie	60 000 t/an	(1981)	70%	30%	152
			Sucrierie Distillerie	62%	(1981)	70%	30%	
			Ficellerie					
			Corderie - Tissage - Filature					

Tableau 6: Commerce international-importation en 1981

Source: Direction de la marine marchande

Principales marchandises importées	Ports de débarquement				Poids en tonnes
	Toamasina	Mahajanga	Antseranana	Toliary	
Hydrocarbures	417 320	-	-	-	417 320
Riz	101 162	3	35 850	21 021	158 036
Ciment	43 059	50 116	9 392	15 742	118 309
Farine	23 405	16 870	1 730	4 389	46 394
Engrais	3 120	3 875	1 346	-	8 341
Huiles alimentaires	11 281	850	3	121	12 255
Produits chimiques	7 412	3 856	988	4 068	16 324
Produits pharmaceutiques	633	351	0,289	6	990,289
Autres produits	95 849	39 635	34 793	6 006	176 283
TOTAL PAR PORT	703 241	115 556	84 102,289	51 353	954 252,289
%	71,2	11,7	8,5	5,2	96,6

Tableau 7: Principales marchandises importées à Madagascar en 1980 et en 1982

Année	1 9 8 0		1 9 8 2	
	Poids en tonnes	Valeur en millions de Fmg	Poids en tonnes	Valeur en millions de Fmg
Riz	55 448	3 192	144 267	13 469
Farine de blé	23 414	1 871	26 572	29 891
Huiles alimentaires	10 010	1 976	9 785	2 600
Boissons alcooliques	265	202	37 304	42
Houille	27 114	353	19 062	462
Hydrocarbures	81 360	6 198	233 482	47 006
Ciment	66 548	1 218	47 198	1 849
Engrais	21 426	1 365	51 165	8 788
Désinfectants, insecticides, fongicides, antiparasitaires	1 167	1 350	787	1 513
Herbicides	117	115	97	191
TOTAL	286 869	17 840	569 719	105 811

Source: Direction des Douanes et des droits indirects (relevé manuel)

Tableau no 8: Principales marchandises embarquées aux quatre ports longs-courriers de Madagascar de 1980 à 1982  
(Poids exprimés en kilogrammes)

Annexe VII

MARCHANDISES	TOAHASINA			MAHAJANGA			TOLIARY			ANTSERANANA		
	1980	1981	1982	1980	1981	1982	1980	1981	1982	1980	1981	1982
Viande bovine	20 944 220	2 055 845	1 343 513	1 467 100	488 262	330 390	-	-	-	-	-	-
Arachides	-	-	-	599 088	127 234	106 222	-	-	-	-	-	-
Bois du Cap	-	-	-	-	-	-	1 311 111	330 265	1 416 204	-	-	-
Café	31 801 000	37 461 000	293 436 626	66 000	62 100	12 000	-	-	-	365 599	475 228	1 392 407
Cacao	195 000	1 373 000	-	-	-	-	-	-	-	-	-	-
Caoutchouc	-	5 000	19 000	-	-	-	-	-	-	-	-	-
Canille	3 454 000	9 287 800	9 138 400	41 900	10 800	1 100 000	-	-	-	-	-	-
Girofle	-	616 500	-	-	-	-	-	-	-	-	-	-
Graines de luxe	50 463	-	144 000	-	-	-	-	-	-	-	-	-
Graines de cacao	281 630	283 551	33 360	41 500	268 195	-	-	-	-	100 403	557 113	253 838
Graines de viande	13 400 000	16 349 700	14 655 600	-	-	-	-	-	-	-	-	-
Graines de graphite	199 690 338	88 296 522	59 060 994	-	-	-	-	-	-	-	-	-
Graines de chrome	587 301	699 396	680 726	-	-	-	-	-	-	-	-	-
Graines de girofle	31 296	697 250	586 208	-	-	-	-	-	-	-	-	-
Graines de cuir	1 272 618	3 061 975	3 169 508	-	97 792	12 874	-	-	-	-	64 777	-
Graines de coton	306 000	1 150 000	683 000	-	-	-	-	-	-	-	-	-
Graines de sapooca	-	-	-	-	-	-	-	-	-	-	-	-
TOTAL	272 014 366	161 336 839	382 950 935	2 215 588	1 054 383	1 561 486	1 311 111	330 265	1 416 204	466 002	1 097 118	1 646 245

Source: Direction des Douanes et des droits indirects (relevé manuel)

Nota: Ces chiffres représentent les 90 pourcent des exportations totales

Tableau 9: Nombre d'hôtels sur le littoral

Regions	Catégories des hotels Nom de la Ville	E t o i l e s *					Ravinala R		
		5*	4*	3*	2*	1*	3 R	2 R	1 R
II	Nosy Be	1	-	2	-	1	-	-	2
	Antseranana	-	-	2	1	3	-	-	1
	Sambava	-	-	-	-	-	2	-	-
	Mahajanga	-	-	2	2	1	3	3	1
III	Morondava	-	-	-	1	1	-	-	-
	Toliary	-	-	2	2	2	1	3	4
IV	Tolagnaro	-	-	1	1	-	1	1	1
	Mananjary	-	-	1	-	-	-	-	-
V	Tomasina	-	1	2	2	3	1	2	1
	Mahavelona	-	-	-	-	1	-	-	-
	Fénériver-Est	-	-	-	-	-	2	1	-
	Sainte-Marie	-	-	-	-	2	-	-	-
	Mananara-Nord	-	-	-	-	-	-	-	1
	Antalaha	-	-	-	-	-	2	-	1
	Ambila Lemaitso	-	-	-	-	-	1	-	1
Vatomandry	-	-	-	-	-	-	-	1	
T O T A L		1	1	12	9	14	13	10	14

Tableau 10: Nombre de touristes chaque année

Mois	1978	1979	1980	1981	1982
Janvier	1 396	885	1 621	1 444	1 584
Février	916	1 106	2 420	1 114	1 557
Mars	1 535	1 069	1 196	1 295	1 329
Avril	1 265	1 596	1 439	1 705	1 329
Mai	1 164	1 493	1 464	1 383	1 426
Juin	1 047	1 266	1 322	1 206	1 390
Juillet	1 430	2 220	2 292	1 247	1 290
Août	1 904	2 465	2 605	2 361	2 625
Septembre	910	1 359	1 519	1 582	1 589
Octobre	2 185	1 559	1 896	1 496	1 486
Novembre	1 480	1 702	1 589	1 191	1 224
Décembre	1 951	1 539	2 094	2 159	1 654
T O T A L	17 183	18 259	21 537	18 181	18 434



Tableau 11: Exemples d'arrivées dans quelques hotels côtiers de 1979 à 1982

Noms des hôtels	Année	Nombre de visiteurs internationaux non résidents	Nombre de visiteurs non résidents-nationaux / étrangers	Total
Holiday Inn (Nosy Be)	1979	3 104	1 946	5 050
	1980	3 140	2 308	5 448
	1981	2 179	1 912	4 091
Zaha-Motel à Amborovy (Mahajanga)	1979	-	-	-
	1980	383	1 470	1 853
	1981	261	1 801	2 062
	1982	-	-	-
Zaha-Motel à Ifaty (Toliary)	1979	-	-	-
	1980	917	645	1 562
	1981	880	1 155	2 035
	1982	-	-	-
Neptune (Toamasina)	1979	747	1 255	2 002
	1980	495	1 087	1 582
	1981	470	1 381	1 851
	1982	1 767	1 103	2 870

Source: Fiche mensuelle de la D.T.O.

Tableau 12: Rentrée de devises pour quatre principaux hotels en 1980 et 1981  
(en millions de Fmg)

Noms des hôtels	1980	1981
Holiday Inn (Nosy Be)	65 376	49 092
Zaha-Motel d'Amborovy (Mahajanga)	16 677	18 558
Zaha-Motel d'Ifaty (Toliary)	14 058	18 315
Neptune (Toamasina)	18 984	22 212
<b>T O T A L</b>	<b>115 095</b>	<b>108 177</b>

ANNEXE III

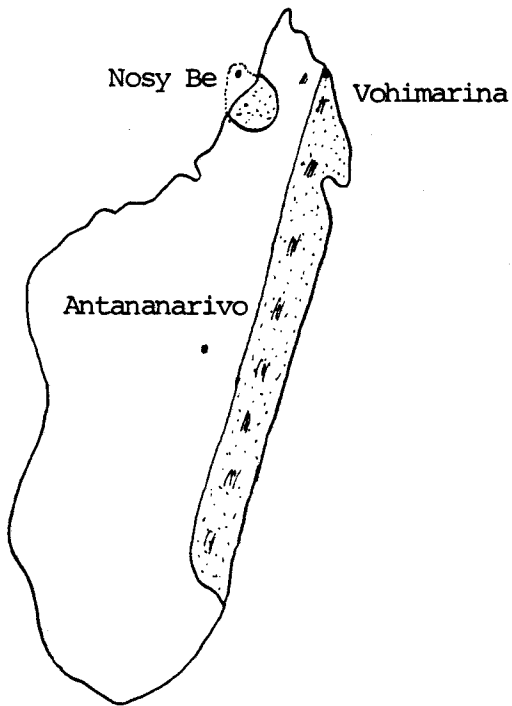

1. Caféier  
(C. robusta)

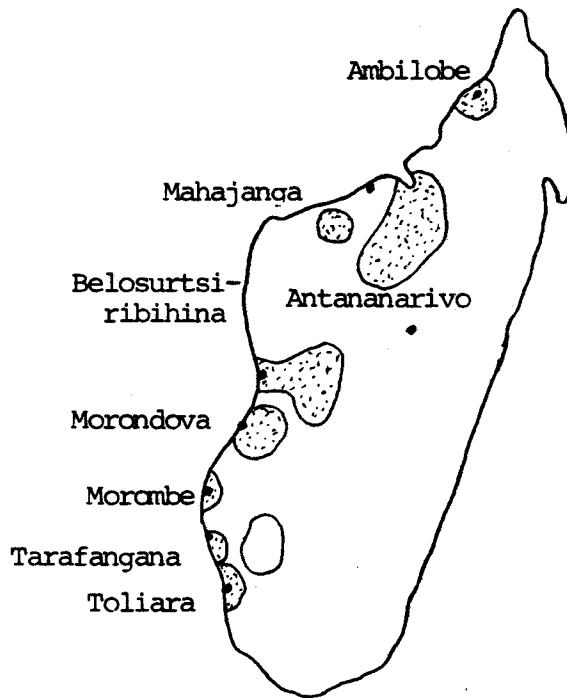

2. Cotonnier

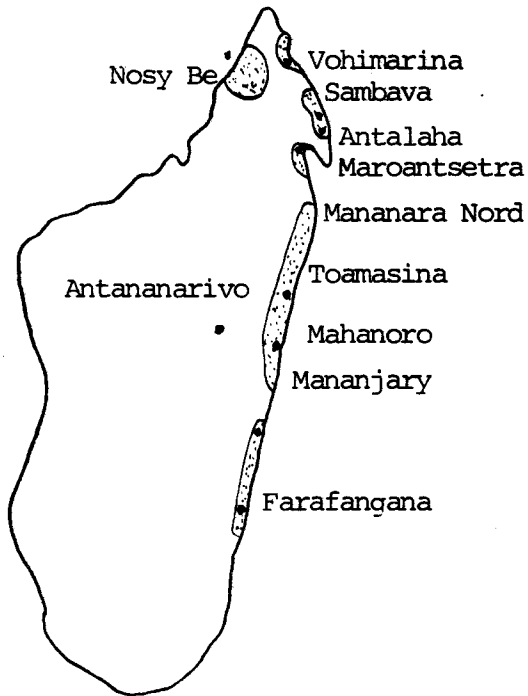

3. Poivrier

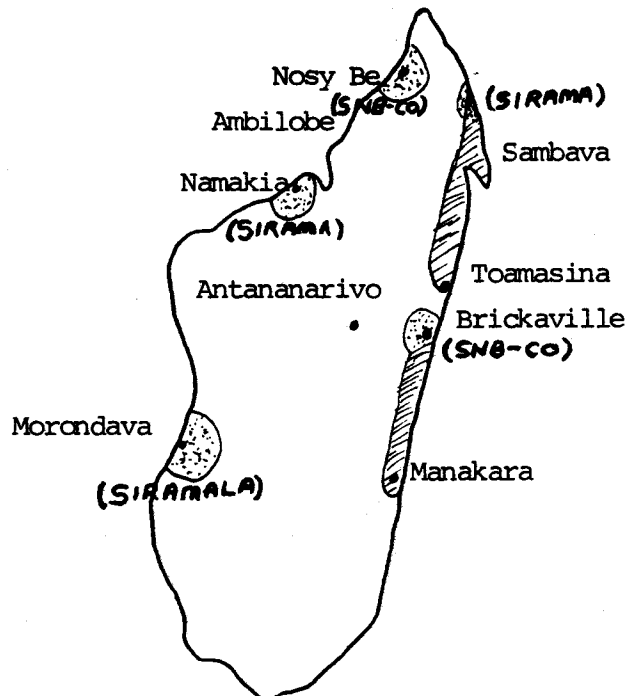

4. Canne à Sucre

 zones cultivées

ANNEXE III (suite)

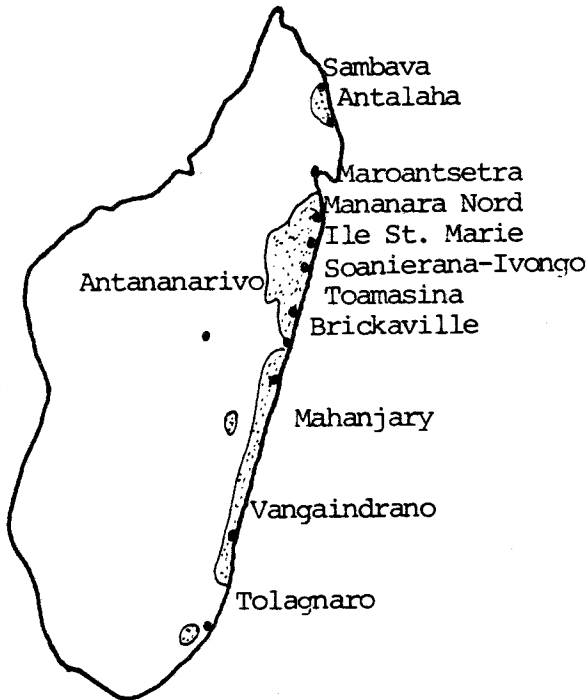

5. Giroflier

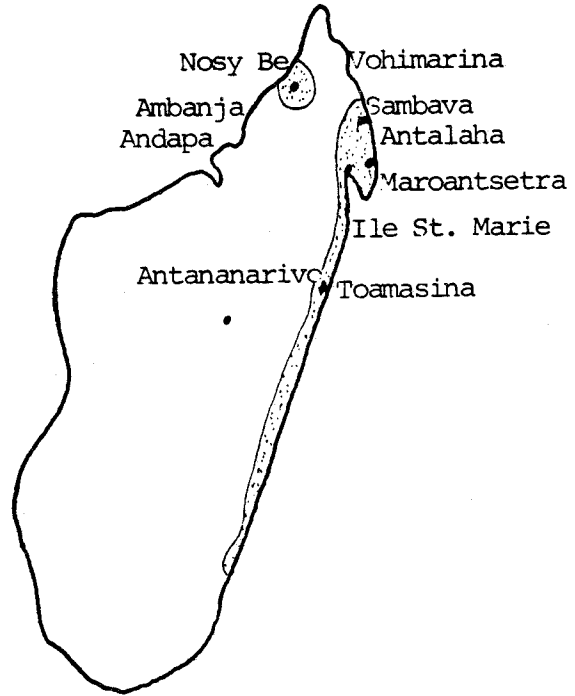

6. Vanillier

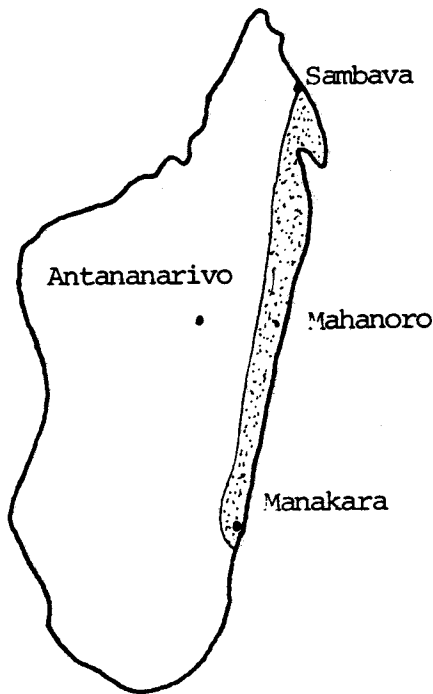

7. Palmier à huile

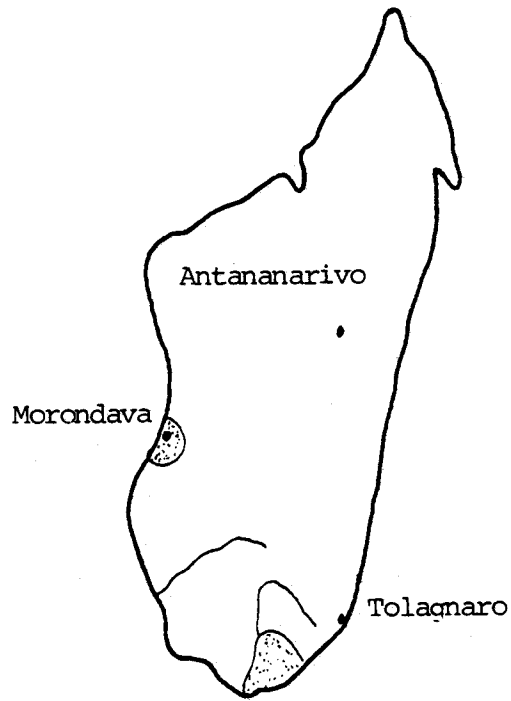

8. Sisal

 zones cultivées

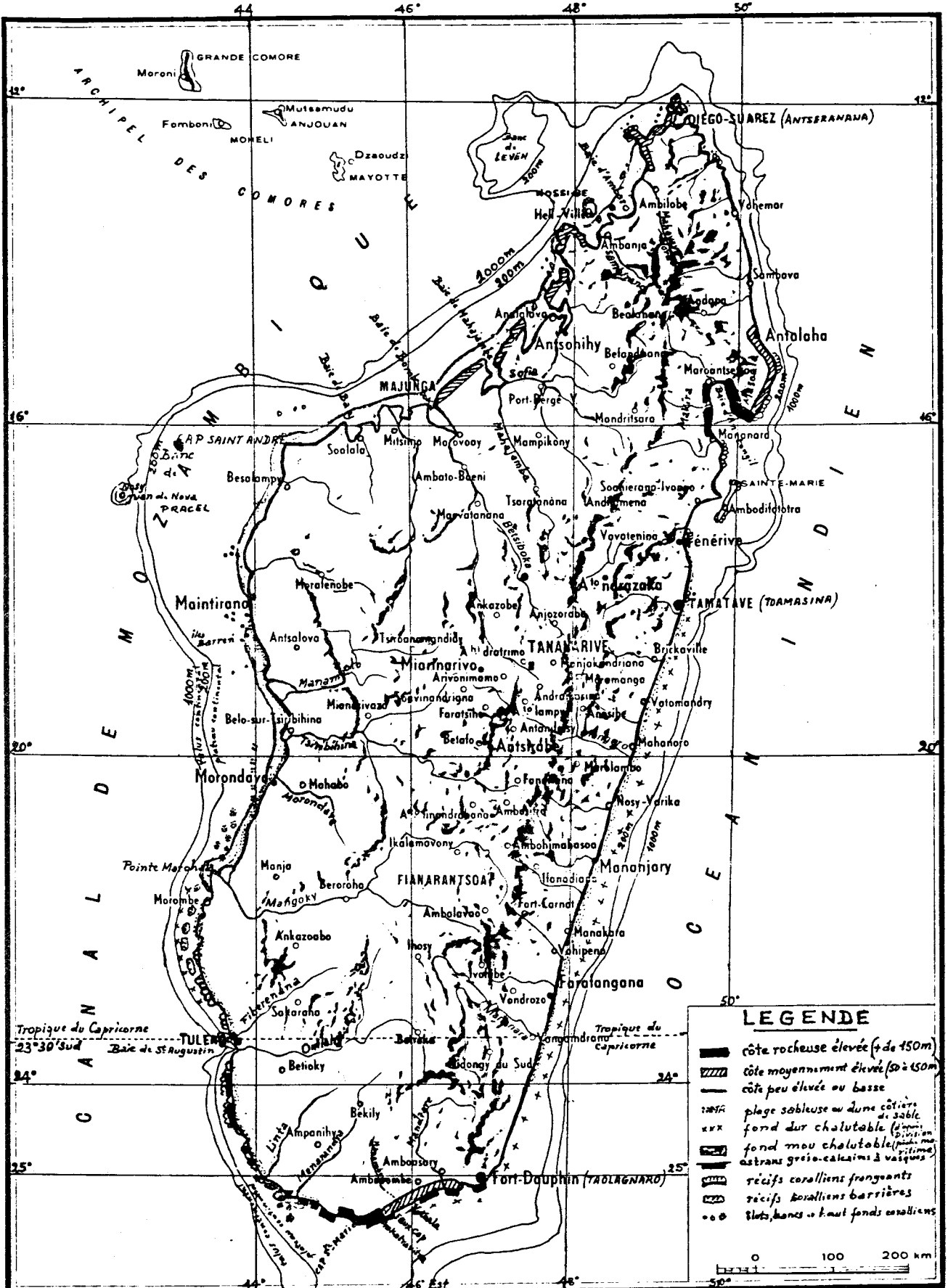

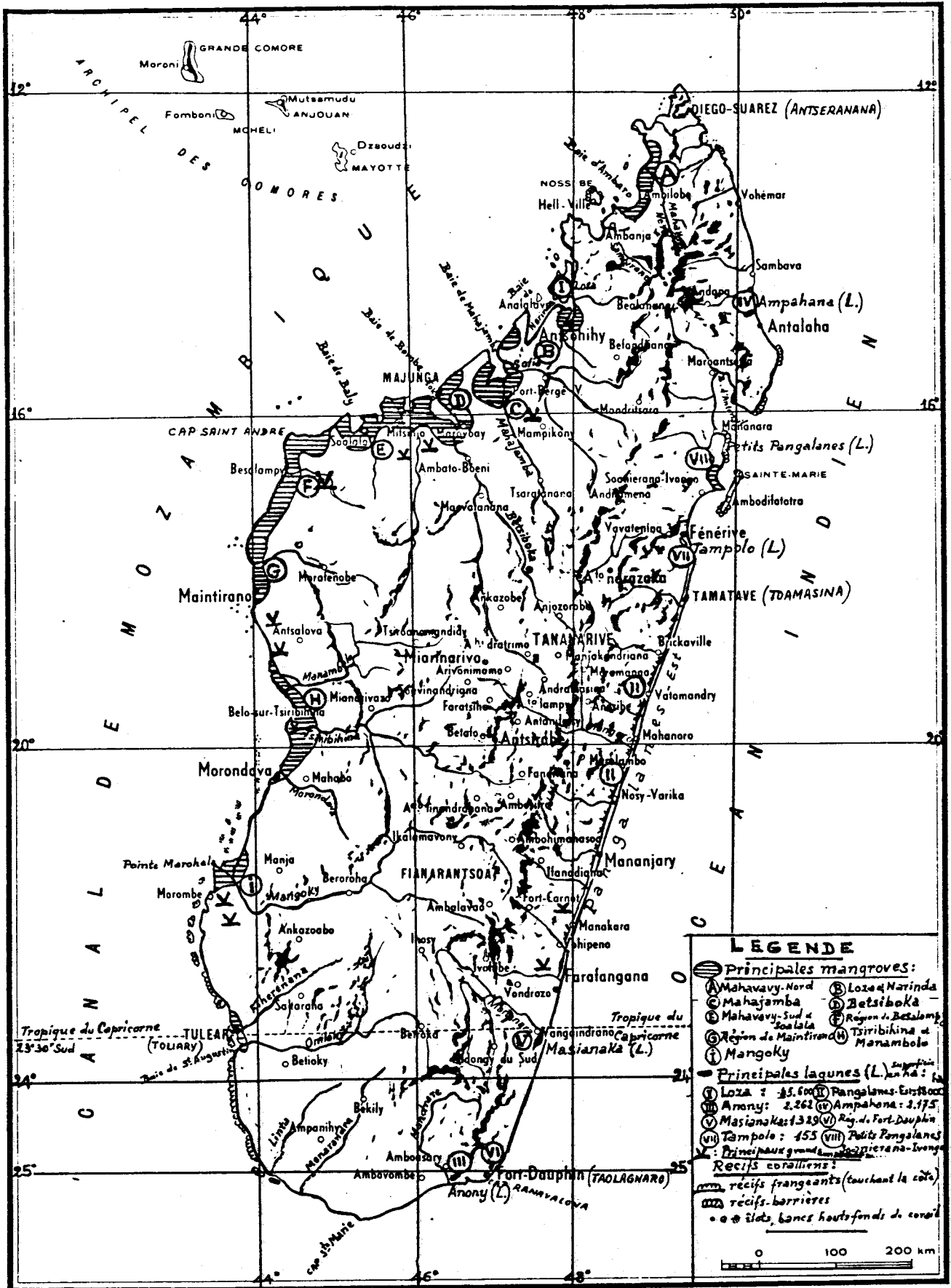

**LEGENDE**

Principales mangroves:

- (A) Mahavavy-Nord
- (B) Loza et Navinda
- (C) Mahajamba
- (D) Betsiboka
- (E) Mahavavy-Sud et Soalala
- (F) Région de Betalampy
- (G) Région de Maintirano
- (H) Tsiribihina et Marambolo
- (I) Mangoky

Principales lagunes (L.) en ha :

- (I) Loza : 85.600
- (II) Pangalanes-Est : 800
- (III) Anony : 2.262
- (IV) Ampahana : 3.175
- (V) Masianaka : 1329
- (VI) Rég. de Fort-Dauphin
- (VII) Tampolo : 455
- (VIII) Petits Pangalanes

Principales grandes lagunes (L.) en ha :

- (I) Principales grandes lagunes (L.) en ha :

Recifs coralliens :

- recifs frangeants (touchant la côte)
- recifs-barrières
- islets, bancs hauts-fonds de corail

0 100 200 km

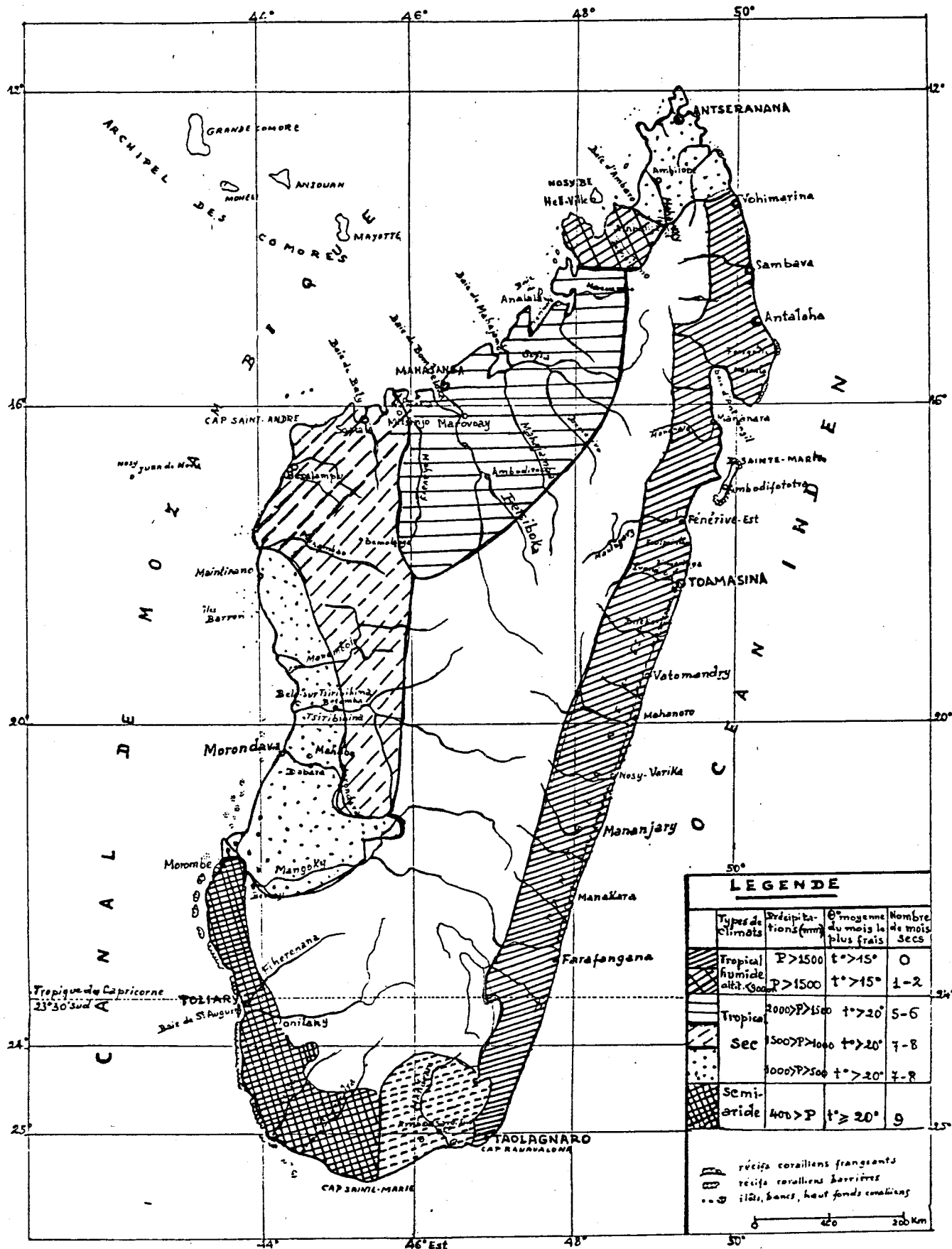

Carte 3: Régions climatiques du littoral

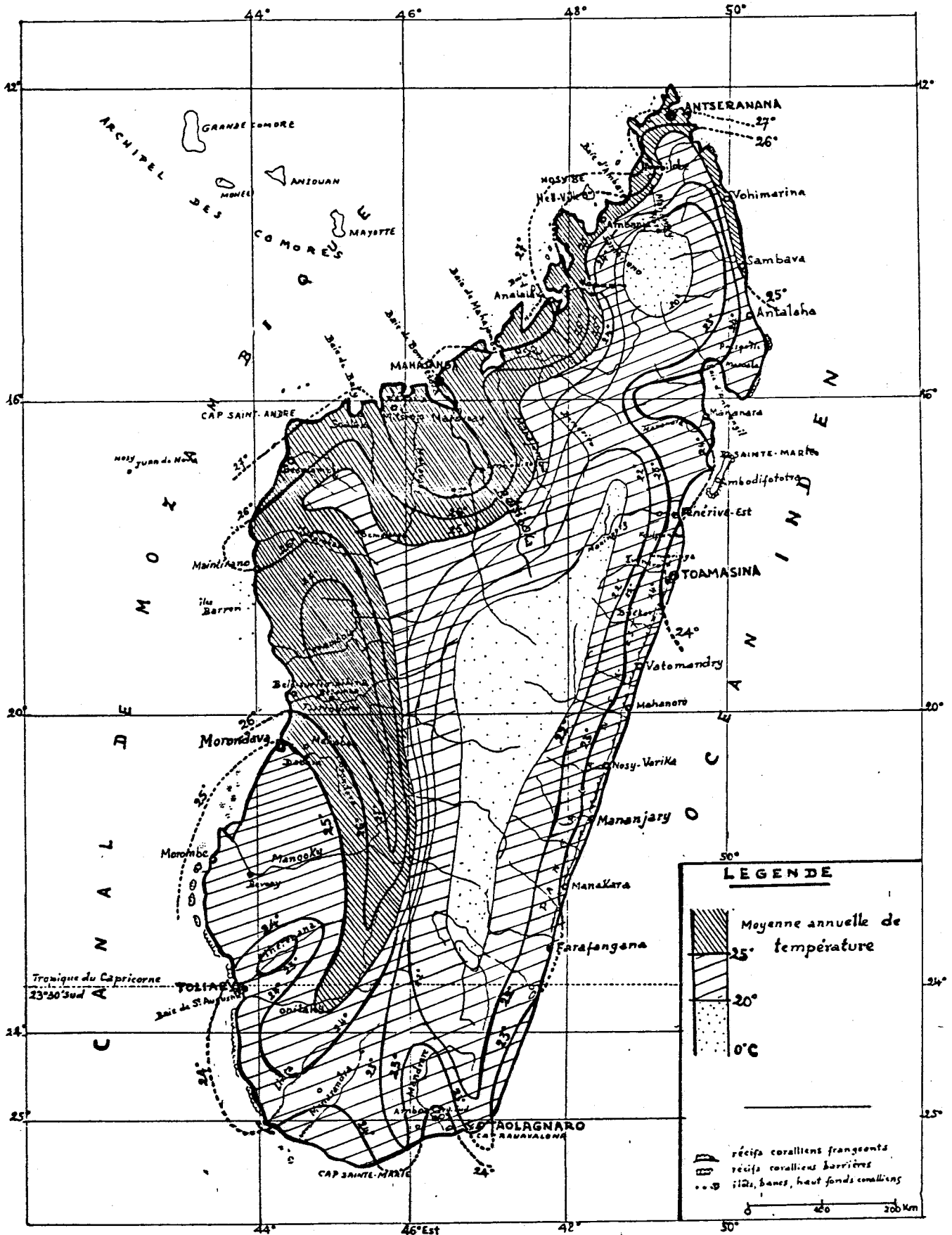

Carte 4: Isothermes annuelles des régions cotières Malgaches

d'après Atlas de Madagascar, 1969

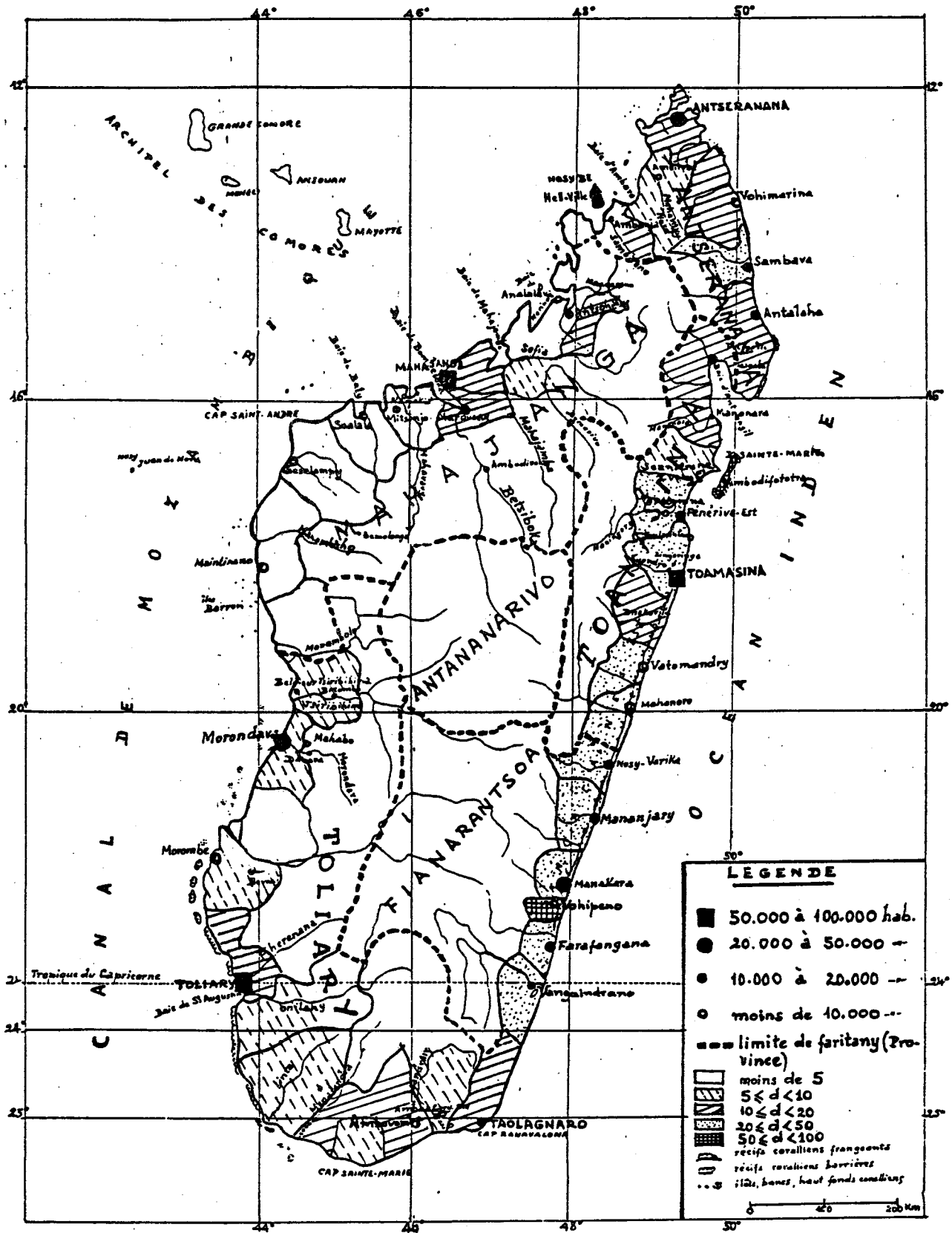

Carte 5: Les centres urbains et la densité de population du littoral (recensement général 1975)

source: INSRE



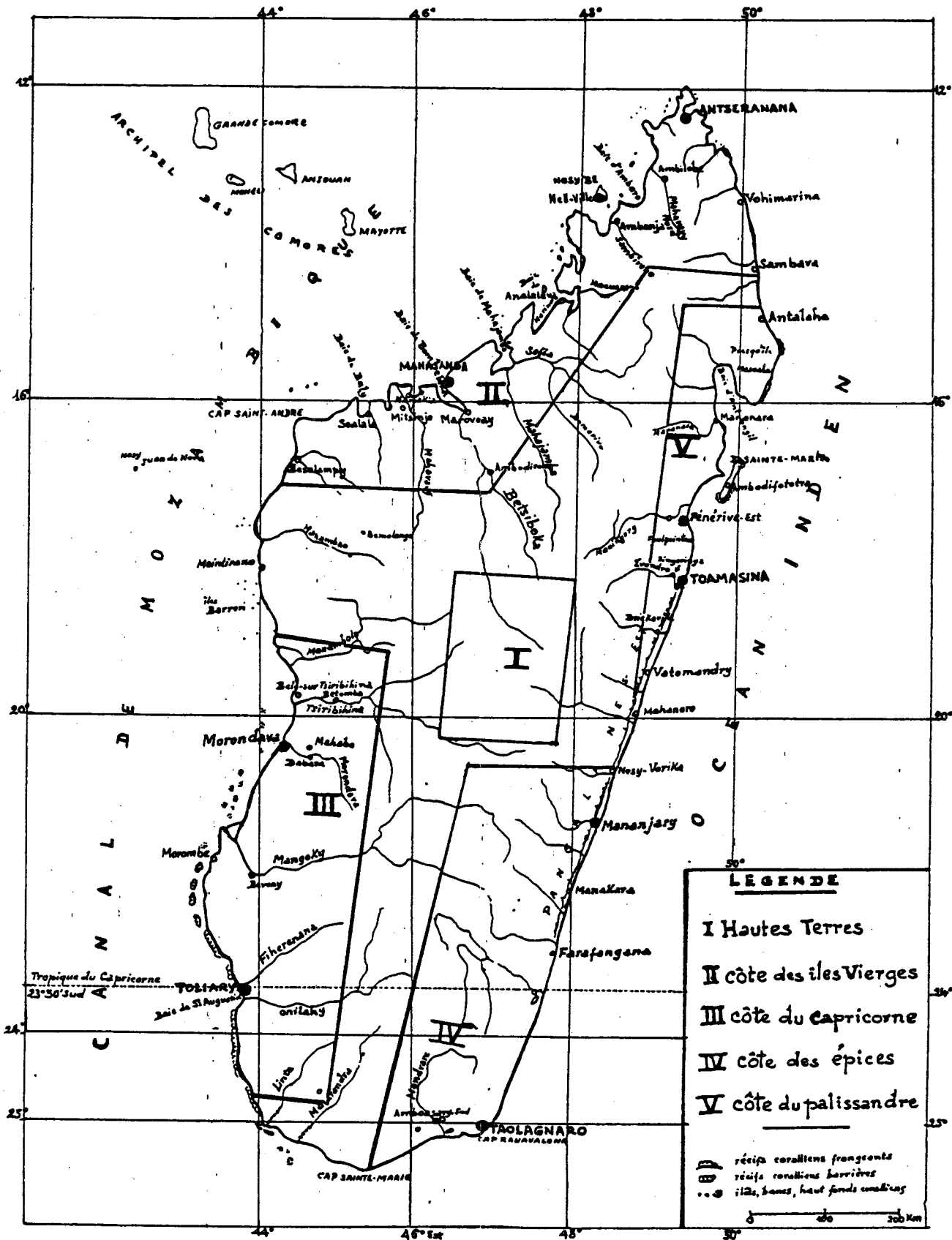

Carte 6: Les régions touristiques de Madagascar

MAURITIUS NATIONAL REPORT : by T.S. Rameyead

BACKGROUND INFORMATION

Nature of beaches, coral reefs, coastline and coastal zone waters

The island is almost totally surrounded by a peripheral fringing reef, about 150 km in total length except for frequent intervals of surge channels, narrow passages and river mouths. The total length of the coastline is about 200 km. The reef is absent on the south coast for about 15.5 km and on two stretches totalling about 10.5 km of the west coast (see map 1).

The morphology of the reef is influenced by several natural factors, such as the strength of the waves, turbidity, water quality, depth and original shape of the basaltic substratum. Faure (1975) divides the fringing reef into six different biotopes.

The external slope. This is the seaward and downward slope of the reef towards deep waters. It consists of spurs and grooves of variable density depending on wave erosion and initial shape of the volcanic substratum. This zone can again be divided into three regions:

- (a) Down to 4 m where the hydrocoral, Millepora and other branched madrepores (e.g. Acropora spp.), Styolophora mordax, Pocillopora damicornis, P. verrucosa, can be found;
- (b) An intermediate zone consisting of encrusting massive colonies (Leptonia phrygia, Platygyra daedalea, Favia speciosa, Montipora sp.) and Alcyonavia of genus Lobophytum, Similaria, Sarcophyton. In caves or overhangs occurring there, madrepores are replaced by calcareous algae, sponges, hydrozoans, byozoans, polychaetes and serpullidis;
- (c) The inferior region towards the sandy external plain where large massive forms such as Porites solida and species of genera Favia and Iuninaria can be found.

The external reef flat, which is an elevated area, also consists of different regions: the top part of the spurs and grooves are occupied by madrepores, hydrocorals and calcareous algae according to the hydrodynamical conditions prevailing. Rough regions are colonized by hardier species such as Millepora platyphylla, whereas madrepores become more numerous in calmer regions and, towards the lagoon, in smaller sizes and in association with fauna comprising numerous echinoderms (Echinometra maltaci, Diadema spp.) and algae such as Amphiroa fragilissima, Corallina polydactyla, Hypnea musciformia, Jania spp. Euchema serra, Halimoda tuna and Sargassum densifolium.

The "detrital ridge" consists of large fragments torn from the external ridge, thrown landwards by rough weather and waves and intertwined with algae.

The internal reef flat begins behind the large fragments and continues towards the lagoon where, after proliferation of living madrepores, the coverage may reach 80 per cent but where many colonies are dead. These may be secondarily covered by encrusting and branched forms of Acropora and Pocillopora. Towards the lagoon, vertical growth of corals is limited.

Map 1 Mauritius

# MAURICE

OCEAN  
INDIEN

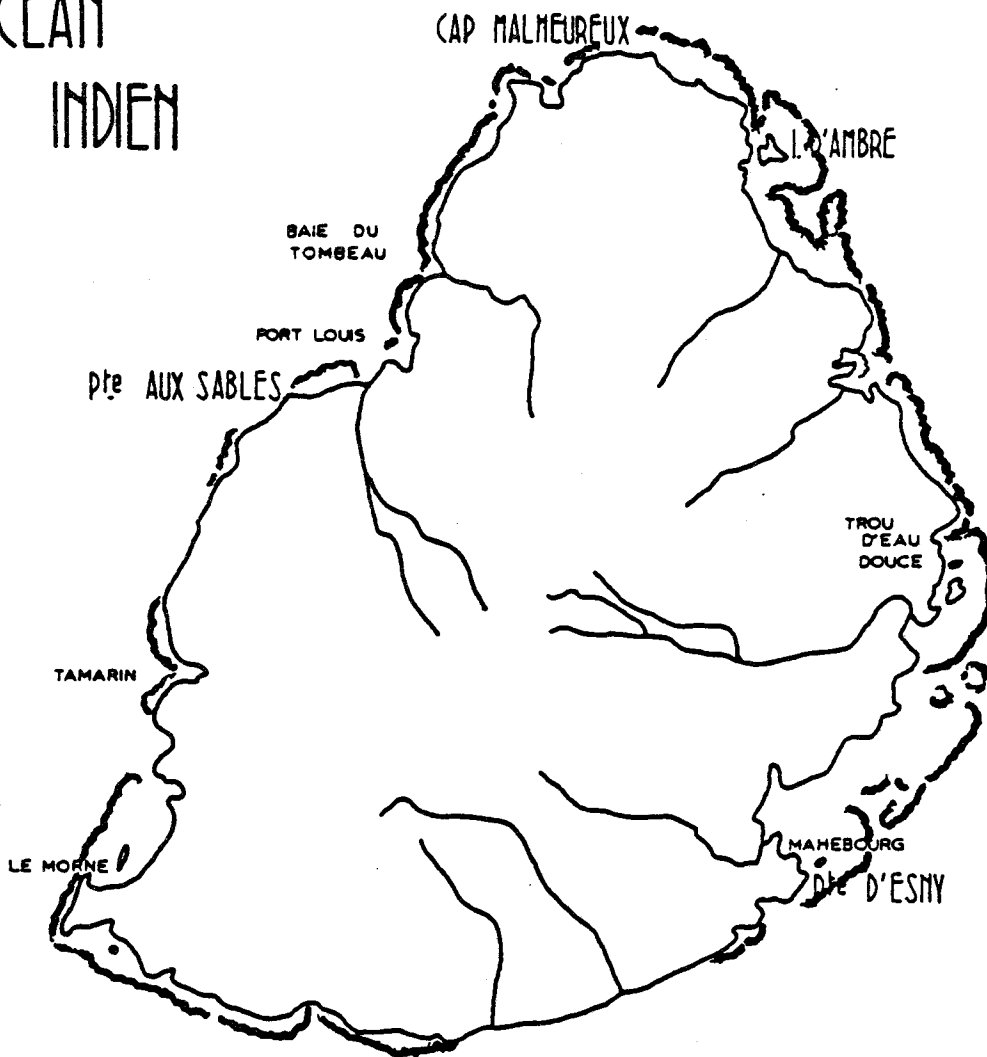

ECHELLE

0 5 10 15 20 km

LEGENDE

Lagoonal patches. The deeper zones of the lagoon are colonized by large Porites sp. and encrusting colonies of Montipora sp, Pavona variana or the branched and unhealthier colonies due to the fact that they are often exposed at low tide, or to fresh water infiltration or sediment from land. Intensive extraction of coral from these patches has contributed to the impoverishment of these colonies.

Morphological discontinuities also exist, such as passes, channels and river mouths causing openings in the reef from the lagoon to the external reef front. The upper sides are colonized by small branched corals, Alcyonaria and calcareous algae. Between 4 and 18 m depth, massive forms (Favia, Goniastrea, Platygyra), large encrusting forms (Echinopora), and smaller colonies of Acanthastrea are found together with Alcyonarians. Below 18 m, various massive and encrusting forms occur as well as the branched Dendrophyllia.

### Mangroves

There are very few mangroves in the coastal zones of Mauritius. These limited pockets of mangrove (especially along the east coast) are sustained at the mouths of rivers which provide sediment inputs, especially during heavy rainfall periods. These relatively small areas are at present not threatened by any activities. It must be noted that the mangrove bark is, to a small extent, used for medicinal purposes. It would be worth while if the various countries of the region exchanged information on this aspect.

### Sites and outflow of the rivers at the coast





There are no navigable rivers in Mauritius. Compared with important rivers discharging at the coast in other countries of the region, the outflows of the few major rivers in Mauritius are very small. In view of the topography of the island, which in general consists of a central plateau surrounded by slopes inclined towards the coasts, nearly all streams and rivers eventually find their way into the coastal lagoons. Map 2 shows the water drainage patterns over the island.

The steady, gradual deterioration of the rivers and their tributaries as a result of unchecked pollution has so far been grossly overlooked by most parties concerned though not entirely through their own fault; the polluted state of several lagoons on the coast is now visibly obvious. Over the past six years or so, various pollution complaints have been lodged at ministerial and parliamentary level. They may be broadly classified as follows:

- pollution (including thermal pollution) caused by the discharge of effluents into canals, streams and rivers from sugar factories during the harvest season;
- discharge of effluents from other industries situated along the banks of watercourses;
- the dumping of refuse into rivers by riverains;
- the release of untreated sewage into lagoons;
- siltation, sedimentation (of lagoons and coastal waters) by soil erosion.

The above-mentioned aspects of pollution are elucidated later in this report.

Map 2

- legende
-  Reservoirs existants
  -  Reservoirs potentiels
  -  Bassins versants
  -  des reservoirs potentiels
  -  Montagnes

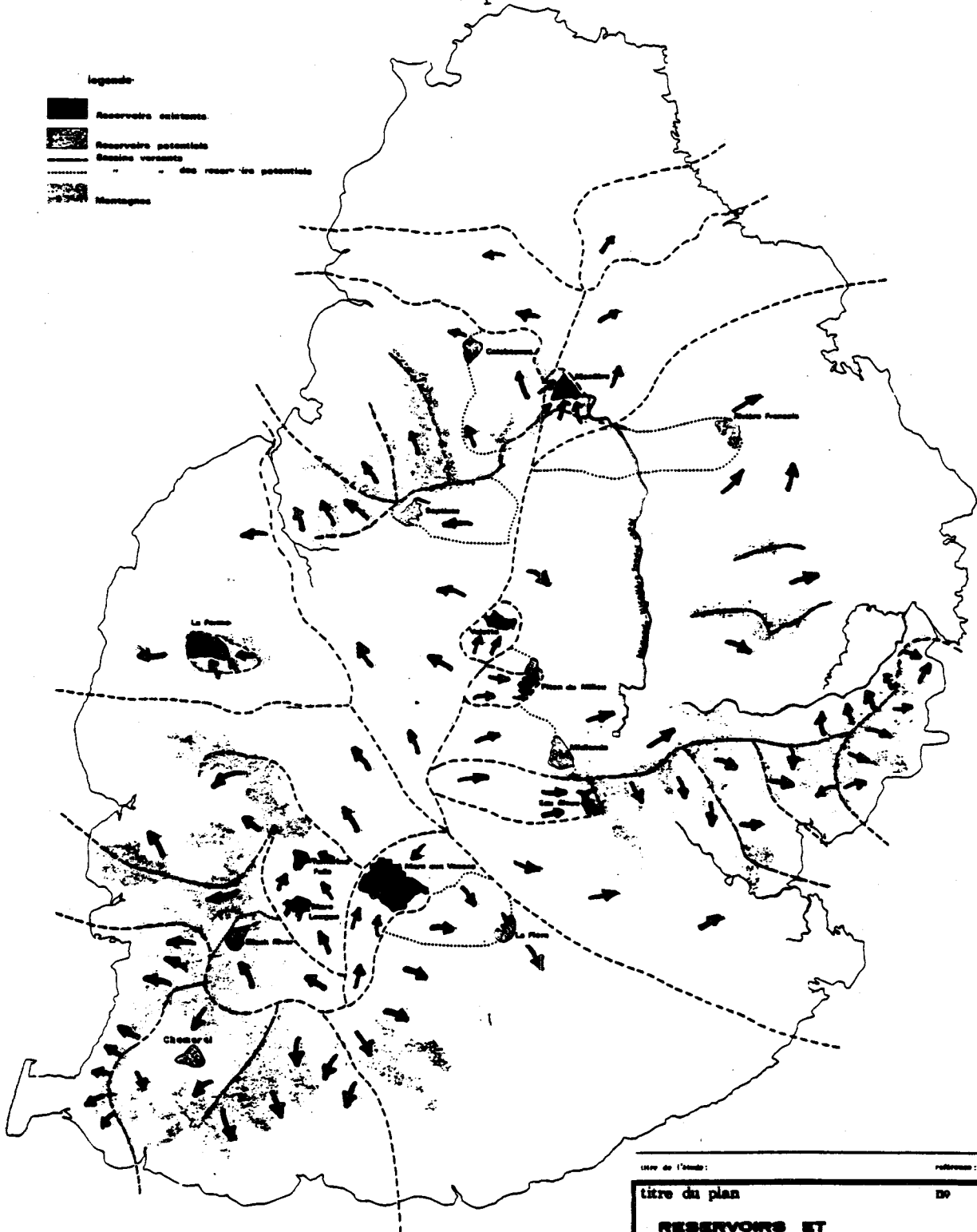

titre de l'étude:	réfèrent:
titre du plan	139
<b>RESERVOIRS ET BASSINS VERSANTS</b>	
source d'information:	échelle: 1:250 000
	date:
révisé le jour et modification:	date:



There are about ten major rivers discharging along the coast whose approximate flows are listed below.

River	Discharge (cusec) at estuary (Dry-weather flow, November)
Grande Rivière South East	134
Rivière des Créoles	127
Rivière la Chau	75
Rivière du Poste	60
Rivière Tamarin	47.5
Rivière Baie du Cap	37
Grande Rivière North West	27
Rivière des Anguilles	18
Rivière du Tombeau	17.5
Rivière du Rempart	5.5

The Grande Rivière South East basin is the largest in the island, covering 103 km<sup>2</sup>. Map 3 shows the drainage areas and river gauging stations on the island.

#### Land-based sources of pollution

The island of Mauritius (comprising Rodrigues and other small outer islets) is one of the smallest countries of the East African regional programme. Mauritius covers an area of about 1,850 square kilometers and is roughly 61 km long and 48 km wide. The total population is about one million. (Population details, including the present population census being carried out, are provided in subsequent sections of this report)

In view of the relatively small size of the island, inland pollution interacts to a significant extent with the coastal and marine environment. It would in many cases be unrealistic to draw demarcation lines between inland activity areas, onshore activity areas, and offshore activity areas; except, perhaps in cases of air pollution which generally affect downwind areas only. The centre of the roughly oval-shaped island lies between 15 to 25 km from the nearest coast.

The following are the major categories of land-based pollution sources having an impact on the coastal and marine environment:

- (a) Discharge of liquid effluents into streams and rivers from sugar factories during the harvest season which normally commences in May/June and lasts for about 200 days). There are 21 sugar factories and about half of them are within a few kilometers of the sea or on the coast itself. The locations of the sugar factories are indicated on map 4.

Sugar is the backbone of the economy. However, the number of sugar factories is definitely not expected to increase; in fact one or two sugar factories are at present appealing to the Government for permission to close down on economic grounds.

For obvious water requirements, most of the sugar factories are located close to streams and rivers and there are constant complaints of pollution from riverains and others residing nearby.

- (b) Effluents from other industries situated directly on the coast, along river banks, and inland industries releasing wastes into sewers and canals which eventually discharge into rivers and lagoons;

Map 3

MAURITIUS DRAINAGE  
AREAS  
AND  
RIVER GAUGING STATIONS

LEGEND  
 ● REGULAR GAUGING STATIONS  
 ○ OCCASIONAL GAUGING STATIONS  
 X ABANDONED GAUGING STATIONS  
 — DRAINAGE AREA BOUNDARIES

MAJOR DRAINAGE AREAS		MINOR DRAINAGE AREAS	
Name	Area in sq miles	Name	Area in sq miles
A DU REMPART (North)	16.1	AB	12.0
B FRANCOISE (North)	20.4	CD	12.2
C DU POSTE (East)	22.4	DE	2.0
D SECHE (East)	17.4	EF	14.0
E O.R.S.E	64.0	FG	1.7
F CHAMPAGNE	6.4	HI	22.0
G DES CREOLES	24.0	JL	1.7
H LA CHAUX	24.8	KL	1.8
I TABAC	6.8	LM	2.2
J DU POSTE (South)	14.3	MS	5.1
K ST AMAND	3.9	NP	6.8
L DRAGON	4.3	PO	12.0
M DES ANHUILLES	12.6	QR	12.1
N SAVANNE	12.2	RS	2.8
O DES GALETES	9.8	ST	2.1
P RIVE DU CAP	12.4	TV	12.8
Q BLACK RIVER	12.9	UV	3.2
R TAMARIN	28.8	VW	7.2
S DU REMPART (West)	22.1	XY	19.7
T BELLE ISLE	5.4	YZ	5.0
U BELLE EAU	15.7	ZA	64.7
V S.R.T.W	46.1		
X ST. LOUIS	5.3		
Y TOMBEAU	19.2		
Z CITRON (North)	12.3		

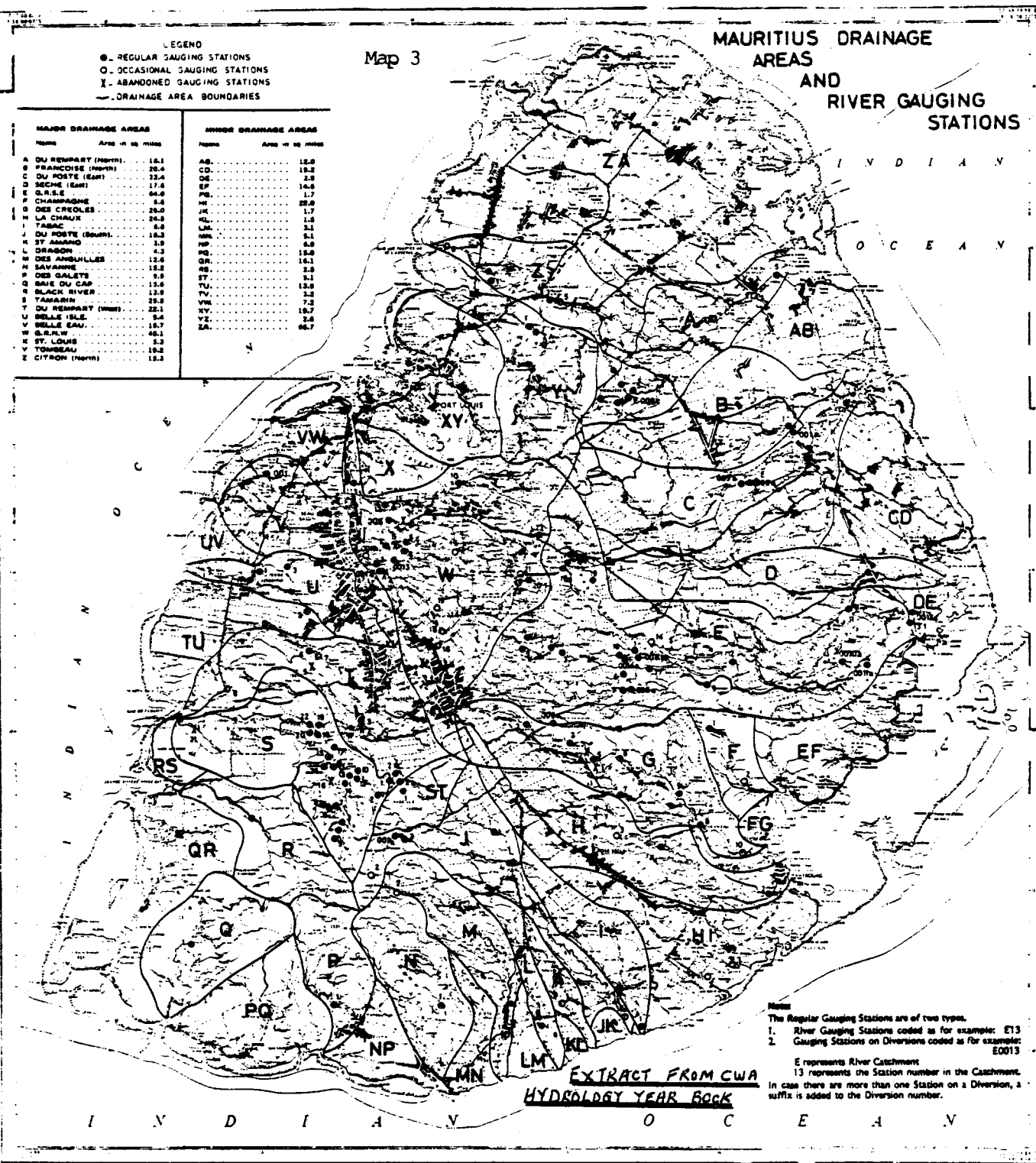

The Regular Gauging Stations are of two types:  
 1. River Gauging Stations coded as for example: E13  
 2. Gauging Stations on Diversions coded as for example: EG013  
 E represents River Catchment  
 13 represents the Station number in the Catchment.  
 In case there are more than one Station on a Diversion, a suffix is added to the Diversion number.

EXTRACT FROM CWA  
 HYDROLOGY YEAR BOOK

I N D I A N O C E A N

Map 4 Fresh water resources and location of sugar mills

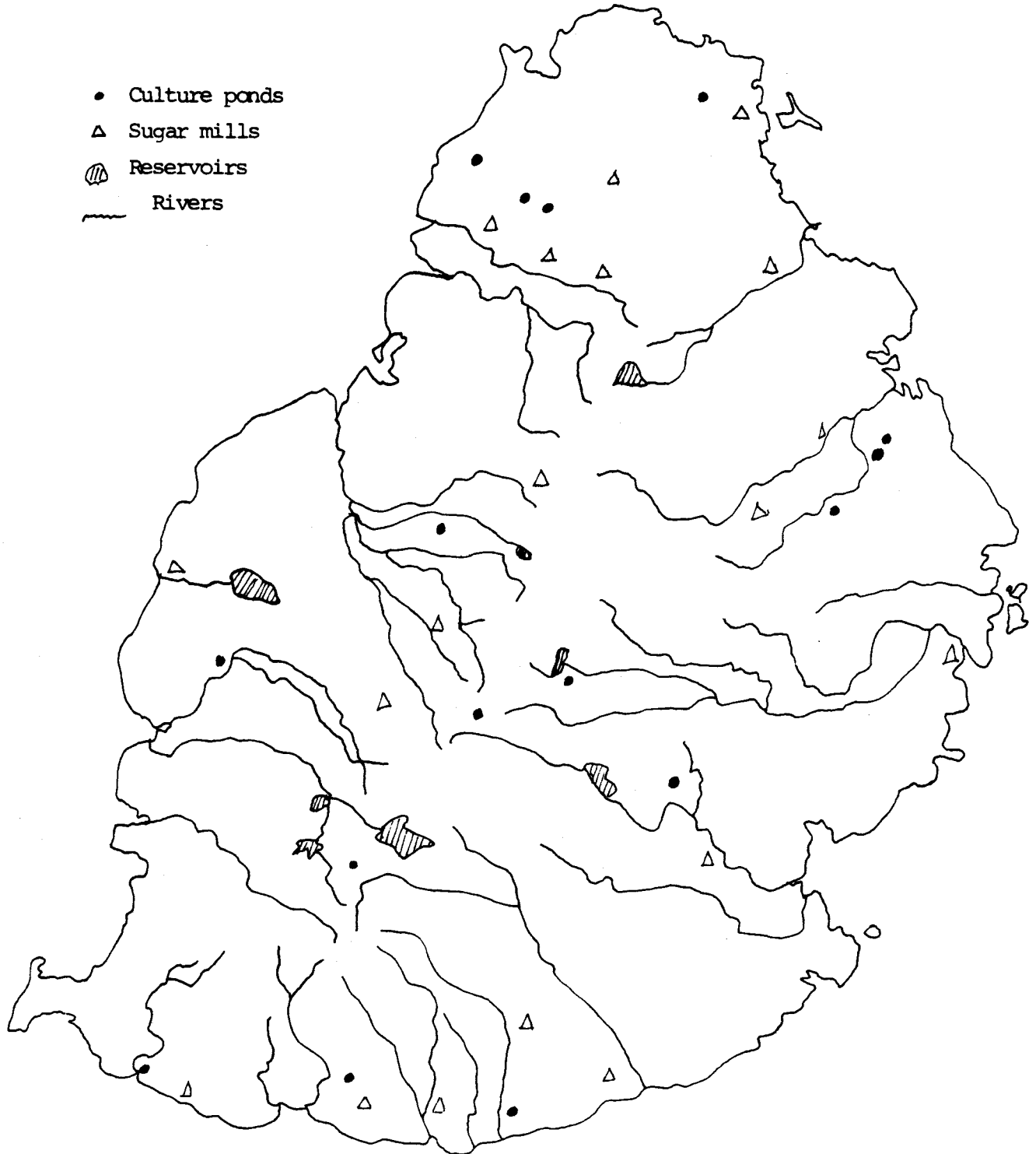



Table 1: Employment in the major groups of economic activities

Industrial group	1973	1974	1975	1976	1977	1978	1979	1980	1981	1982
Agriculture and fishing	58,919	56,847	58,157	59,459	61,348	58,410	55,612	54,014	53,456	52,388
Sugar	49,961	48,223	50,612	52,620	54,391	51,332	48,714	47,493	47,271	46,445
Tea	7,119	7,080	5,455	4,741	4,917	5,467	5,159	4,963	4,582	4,747
Tobacco	1,101	840	1,345	1,279	1,199	779	924	857	729	275
Other	738	704	745	819	877	832	815	701	874	921
Mining and quarrying	163	153	148	149	143	120	148	145	147	147
Manufacturing	13,489	18,480	21,126	26,416	30,941	31,954	35,141	36,172	36,889	37,980
Electricity and water	2,598	2,880	2,935	3,062	3,304	3,518	3,930	4,639	4,430	4,451
Construction	3,762	4,969	5,844	7,806	7,309	8,846	9,164	8,144	7,257	5,538
Wholesale, retail trade, restaurants and hotels	5,787	6,507	6,412	7,599	8,182	9,058	9,402	9,297	9,122	9,14
Transport, storage and communication	6,809	8,163	9,260	9,027	10,217	9,820	9,981	8,656	7,842	8,351
Financing, insurance, real estate and business services	2,155	2,412	2,671	2,962	3,531	4,059	4,316	4,369	4,576	4,669
Community, social and personal services	50,085	49,737	50,269	52,443	54,583	57,634	61,642	62,712	62,822	63,488
Government:										
Central	41,445	40,727	41,370	42,552	42,841	44,528	47,820	48,728	49,029	49,737
Local	3,278	3,163	3,360	3,617	4,557	4,988	5,251	5,389	5,522	5,536
Other	5,362	5,847	5,539	6,274	7,185	8,118	8,571	8,595	8,271	8,215
Activities not elsewhere specified	6,473	6,221	7,642	7,816	14,438	11,749	10,293	8,118	6,913	6,376
<b>GRAND TOTAL</b>	<b>150,240</b>	<b>156,369</b>	<b>164,464</b>	<b>176,739</b>	<b>194,032</b>	<b>195,168</b>	<b>199,629</b>	<b>196,266</b>	<b>193,454</b>	<b>192,537</b>

Table 2: Employment in specified sectors (September 1978 - September 1981)

	1978	1979	1980	1981
(a) Sugar industry				
Total employed by:				
Planters (including metayers)	7,652	7,373	6,793	7,007
Millers' estates and annexes (including factories)	46,330	45,295	44,353	43,047
<b>TOTAL</b>	<b>53,982</b>	<b>52,668</b>	<b>51,146</b>	<b>50,054</b>
(b) Manufacturing industries				
Industrial group				
Food	2,417	2,460	2,631	2,669
Beverages and tobacco	2,639	2,535	2,522	2,314
Textiles	1,994	2,309	2,136	2,215
Wearing apparel	14,759	16,337	17,434	19,765
Wood and furniture	969	1,132	1,111	1,000
Paper products	364	302	335	330
Printing and publishing	1,266	1,160	1,120	1,105
Rubber and leather products	681	601	563	639
Miscellaneous chemical products	963	974	1,050	1,048
Plastic products	123	137	128	144
Non-metallic mineral products	1,474	1,533	1,650	1,499
Iron and steel basic industries	365	489	427	359
Metal products	576	651	731	605
Machinery:				
Electrical	1,726	2,097	1,567	439
Non-electrical	768	772	758	697
Transport equipment	749	715	770	683
Watches and clocks	153	213	280	347
Jewellery and related articles	463	530	438	479
Miscellaneous manufacturing industries	628	642	709	822
<b>TOTAL</b>	<b>33,077</b>	<b>35,589</b>	<b>36,360</b>	<b>37,159</b>

National infrastructures concerned with environmental issues and management

The following Ministries, parastatal bodies and non-governmental organizations (NGOs) are institutions directly, or indirectly, and currently concerned with environmental issues, in Mauritius. Their functions, financial and human resources and trained manpower are indicated under the respective headings below. A few other NGOs concerned have not been mentioned; information regarding their official registrations (as organizations, youth clubs, movements, etc.) not being readily available.

(1) Ministry of Housing, Lands and the Environment

Responsibility for matters related to the environment (conservation and pollution aspects involved in projects of various kinds) was first given to the Ministry of Agriculture, Natural Resources and the Environment in the year 1976/77. Prior to the period of 1976 this Ministry was the Ministry of Agriculture, Natural Resources and Fisheries. Before 1976, there was no Ministry 'officially' responsible for environmental issues as such, nor did it include 'Environment' in its official title. UNEP, UNDP (United Nations Development Programme), UNESCO's MAB (United Nations Educational, Scientific and Cultural Organization, Man and the Biosphere Programme), FAO (Food and Agriculture Organization) and other international organizations have played, and are still playing, a significant role in creating environmental awareness in developing countries like Mauritius.

With a change of government in June 1982, the former ministry of Housing, Lands and Town and Country Planning became the present Ministry of Housing, Lands and the Environment. This ministry comprises a Survey Division, a Valuation Division and an Environment Division, including Town and Country Planning.

The head of the Environment Division still bears the official status of 'Chief Town and Country Planning Officer'-C.T.C.P.O.). The present objectives and functions of the Ministry of Housing, Lands and Town and Country Planning are given below. Environmental management and preservation are now fully recognized by most governmental, parastatal and non-governmental organizations. Any forthcoming government would most certainly support the views and recommendations of UNEP's present East African regional seas programme. The objectives and functions of the Ministry are as follows:

- advising the Minister on the formulation of policy in connection with matters falling within his portfolio;
- the judicious application of the relevant legislation and the introduction of new or amended legislation;
- supervising the associated divisions and ensuring co-ordination among them;
- dealing with establishment matters generally, including staff administration and staff relations;
- the proper control of expenditure voted by the Legislative Assembly;
- the collection of revenue in respect of leases of Crown lands, Pas Géométriques, sand quarries;
- the leasing of Crown lands and Pas Géométriques as building or camping sites and for cultivation, industrial hotel development and other purposes;

- the administration of Crown lands and Pas Géométriques;
- land surveying and mapping;
- the acquisition of buildings and land for public purposes;
- the exchange of Crown lands against private lands;
- the valuation of lands and buildings to be acquired or rented by the Government;
- the preparation of outline schemes and final development schemes for planning areas, taking into account all environmental considerations, including the setting up of the necessary ministerial collaborations (and collaboration among other bodies) to ensure the proper implementation of the above objectives.

The Ministry is also charged with general responsibility for the activities of the Central Housing Authority and the Town and Country Planning Board.

#### Financial resources

The expenditure voted for this Ministry (financial year 1982-83, ending 30 June 1983) was Rs. 11,244,000.00. The capital budget for physical planning and cadastral survey, land acquisition, improvement of infrastructure on housing estates, urban sector development etc. was Rs. 59,950,010.00. (This excludes external fundings, e.g. EDF, US Agency Housing Project). Revenue figures are generally significantly less than the figures quoted and have not been indicated. The Ministry's revenues include the sale of coral sand, maps and reproductions.

#### Manpower (1982-1983)

The Ministry's staff totals about 760 of whom about 50 hold professional qualifications (university degrees, diplomas, etc.).

#### (2) Ministry of Health

The functions and objectives of this Ministry are:

- to investigate the influence of social environment and domestic factors on the incidence of human disease and disability;
- to plan and carry out measures for the promotion of health;
- to institute and maintain measures for the prevention of diseases;
- to provide a quarantine service for preventing the introduction of infectious quarantinable diseases by sea or air;
- to provide facilities for treatment of disease, including mental disease, by maintenance of hospital and dispensary services;
- to make provisions for the rehabilitation of the disabled;
- to control the practice of medicine, dentistry and pharmacy;
- to provide facilities for the training of nursing officers, midwives, ancillary hospital and laboratory staff and health inspectors;

- to advise local government authorities regarding their health services and to inspect those services;
- to prepare and publish reports and statistical or other information relating to health; and
- to implement a family planning, maternal and child health programme.

The activities of the Ministry are co-ordinated by the Permanent Secretary assisted by the Principal Assistant Secretary and Administrative Officers on the administrative side, by the Chief Medical Officer, Principal Medical Officers, one Chief Hospital Administrator and a Nursing Officer-in-chief with a deputy on the technical side.

The Principal Assistant Secretary is the Head of the Administrative division. This division is concerned with the formulation of policy and handling of all establishment and personal matters, the control of expenditure, the collection of revenue, office organization and management and generally all administrative and executive matters.

#### Financial resources

Expenditure voted for 1982-83 was Rs. 241,000.00. The capital budget including population control for 1982-83 was Rs. 21,750,000.00

#### Manpower

Total staff: 3,553; professional staff (doctors, sanitary engineers, specialists in various fields of medicine) number about 1,500.

Regional, district and specialized hospitals; dispensaries, health offices, family planning centres, etc. are shown on map 5.

#### (3) Ministry of Agriculture, Fisheries and Natural Resources

The objectives and functions of this Ministry are as follows:

In virtue of the powers conferred upon the Minister by sub-section (i) of section 3 of the Ministry of Agriculture and Natural Resources (Integration) Ordinance, 1963, as subsequently amended, the powers and duties exercisable under any law in force by the Chief Agricultural Officer have been transferred to the Permanent Secretary under the Ministry of Agriculture, Fisheries and Natural Resources (Transfer of Power and Duties) Order 1972 made on 31 January 1972 and which came into force on 5 February 1972.

The Chief Agricultural Officer advises the Permanent Secretary on matters referred to him: policy, administrative and technical. He is responsible for the planning, co-ordination and execution of the work of the different divisions of the technical services of the Ministry, which except for the Forestry Service, are grouped in the Agricultural Services. He is assisted by three Principal Agricultural Officers. The first Principal Agricultural Officer is responsible for the co-ordination and implementation of the approved programme of work of divisions involved with crop production, viz. Agricultural Division, Crop Experiment Stations, Seed Production and Plant Propagation, Plant Pathology, Entomology and Agricultural Chemistry; the next Principal Agricultural Officer is responsible for the co-ordination and implementation of the programme of work of the Animal Production Division, Livestock Breeding Stations, Division of Veterinary Services,

Map 5

1. ● REGIONAL HOSPITAL
2. ⊕ DISTRICT HOSPITAL
3. ⊖ SPECIALISED HOSPITAL
4. ⊕ DISPENSARY
5. ⊙ HEALTH OFFICE
6. ⊙ MATERNAL & CHILD HEALTH & FAMILY PLANNING CLINIC
7. ⊙ FAMILY PLANNING CENTRE
8. ⊙ DENTAL CLINIC

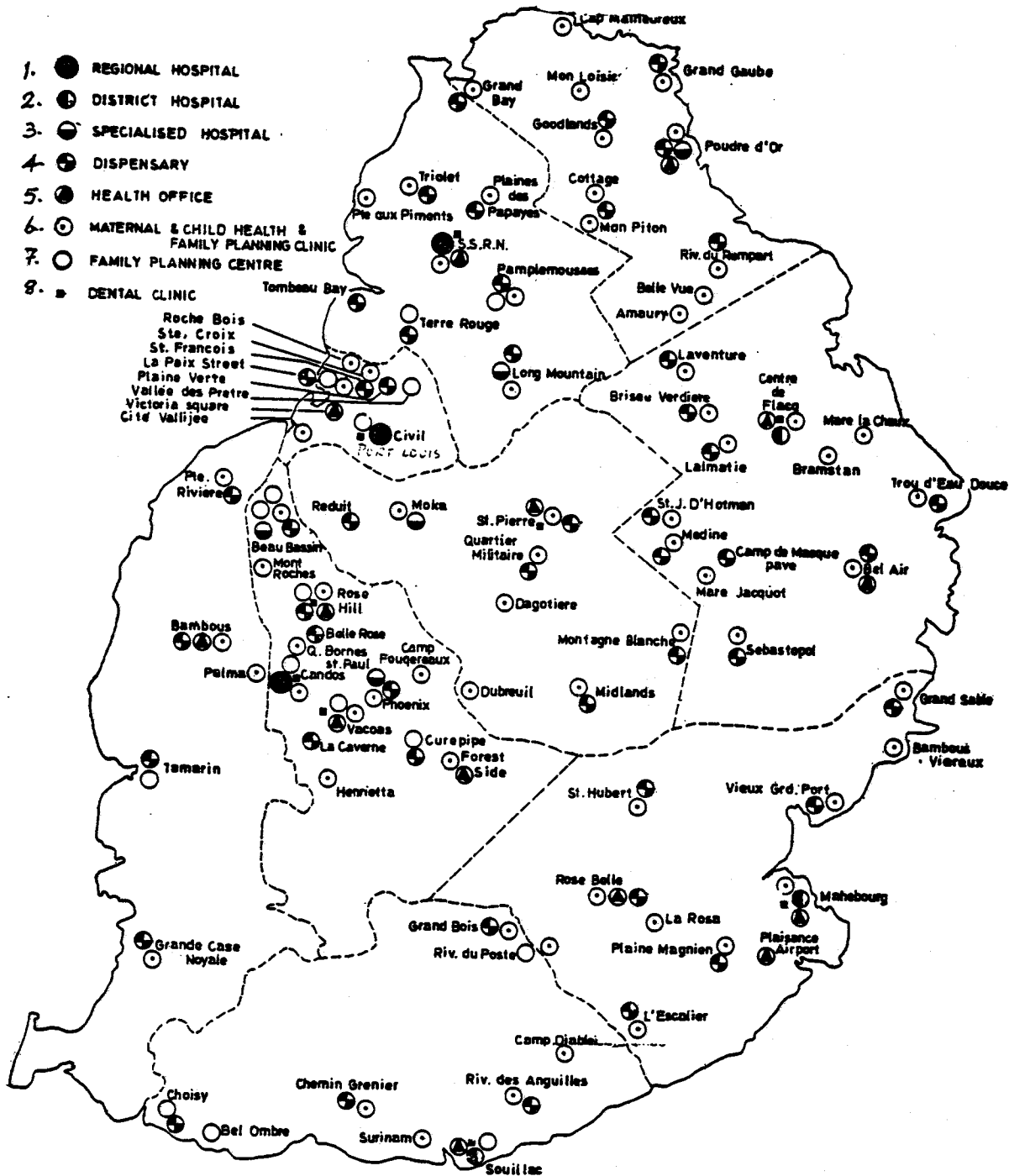

government health institutions

*Since the publication of this map, the items listed under legends 4 to 8 have been improved and increased in number. Refer to Health Services statistics*

Cartographic Section,  
Ministry of Housing, Lands and the Environment

Dairy Chemistry Division and Rodrigues Division; the third Principal Agricultural Officer is responsible for the co-ordination and implementation of the programme of work of the Extension Services Division, Land Use and Projects Division, Engineering Division and Field Services Division. The Cane Planters and Millers Arbitration and Control Board falls technically under the responsibility of the Chief Agricultural Officer.

The Chief Agricultural Officer and the Principal Agricultural Officers also serve on a number of Boards and Committees either as chairman or as members. These Boards and Committees are listed below. They fall under the responsibility of the Ministry of Agriculture, Fisheries and Natural Resources. They submit their own annual reports.

#### Boards and Committees

##### Ministry of Agriculture, Fisheries and Natural Resources

The Permanent Secretary or his representative serves on the following boards and committees:

Agalega Corporation Board  
Agricultural Marketing Board  
Board of Agriculture, Fisheries and Natural Resources  
Board of Examiners for the Registration of Agricultural Chemists  
Cane Planters and Millers Arbitration and Control Board  
Cane Release Committee  
Institute of Education Council  
Irrigation Committee  
Land Settlement Committee  
Mauritius Meat Authority  
Mauritius Sugar Industry Research Institute Executive Board  
Mauritius Sugar Industry Research Institute Advisory Board  
Pesticides Control Board  
Rose Belle Sugar Estate Board  
Sugar Industry Development Fund Committee  
Sugar Insurance Fund Committee  
Sugar Millers Development Fund Committee  
Sugar Planters Development Fund Committee  
Sugar Planters Mechanical Pool Corporation Board  
Tea Board  
Tea Development Authority  
Tobacco Board  
University of Mauritius, Senate  
University of Mauritius, Council

The transfer of the Ministry of Fisheries to the present Ministry of Agriculture, Fisheries and Natural Resources is explained under "Ministry of Housing, Lands and the Environment". The Fisheries Department operates under the administration of the Permanent Secretary and is headed by a Principal Assistant Secretary.

#### Financial resources

Expenditure voted for 1982-83 was Rs. 69,600,000.00. This includes agriculture Rs. 38,414,800.00, fisheries Rs. 8,300,000.00 and forest Rs. 12,607,880.00. The capital budget for 1982-83 was Rs. 76,630,070.00. External fundings, project values have not been indicated. Agriculture revenues for 1982-83 were Rs. 15,084,020.00, for forest Rs. 800,000.00 and for fisheries (Ministerial only which excludes total

#### Manpower

Total manpower: about 8,000; the professional staff numbers about 400.

#### (4) Ministry of Commerce, Industry, Prices and Consumer Protection

Objective and functions: This Ministry is responsible for the following activities and projects:

- processing the official formalities for the implementation of industries; development certificates; development permits for the Export Processing Zone and for industries manufacturing products for local consumption;
- constant monitoring and compilation of data on the numbers and types of industries throughout the island;
- import/export control of raw materials for industrial and commercial enterprises (in close collaboration with the Customs Department);
- collaboration with other Ministries/organizations (including the Ministries of Housing, Lands and the Environment, Local Government, Finance, the Mauritius Chamber of Commerce and Industry, Customs Department, Civil Aviation for air-cargo handling, etc.) for the implementation of the above mentioned items and feasibility studies concerning them;
- control/monitoring, price fixing, of consumer goods (this is steadily attaining good control levels);
- preparations/strategies to encourage foreign industrial investments beneficial to all parties concerned.

#### Financial resources

Expenditure voted for 1982-83 (including Prices and Consumer Protection, Mauritius Standards Bureau) was Rs. 11,136,000.00. The capital budget (not including external fundings, projects, etc.) was Rs. 4,050,020.00. This includes Trade & Industrial Promotion Rs. 4,000,000.00, Investigation and Market Research Rs. 10,000.00, Administration Block for EPZ Rs. 10,000.00 and Standards Bureau Rs. 50,000.00 (these figures are as quoted in the Government's Capital Budget). Revenues was about Rs. 300,000.00 (unconfirmed figure).

#### Manpower

Total manpower is about 500 but the setting up of sub-departments in this Ministry have probably altered this figure.

The professional staff consists of about 20 per cent of the total manpower of the Ministry.

#### (5) Ministry of Works

This Ministry has recently undergone several changes in its departmental structures, e.g. the creation of a 'National Transport Authority' under its aegis.



The Ministry comprises Departments or Divisions responsible for the following aspects:

- administration (Minister, Permanent Secretary, Principal Assistant Secretary, etc.);
- mechanical Division (engineers, architects, quantity surveyors);
- construction, maintenance of roads, bridges;
- sewerage - conveyance and disposal - national basis;
- transport and other transport-related issues;
- processing of development permits for residential buildings in rural areas (i.e. those falling under District Councils as opposed to Municipalities in the five main urban zones), development permits for such purposes as small-scale industries (rural areas) and commercial enterprises. In principle, collaboration with all other Ministries or organizations concerned is adhered to.

#### Financial resources

Expenditure voted for 1982-83 was Rs. 109,792,000.00. The capital budget (not including external fundings, projects etc.) was Rs. 101,800,100.00. This breaks down as follows: sewerage Rs. 19,000,020.00, roads Rs. 34,300,050.00 and other public works Rs. 48,500,030.00. Revenues were about 5 to 7 million rupees.

#### Manpower

Total manpower: about 10,000; the professional staff is about 200 to 300.

The financial resources and manpower of the newly set-up organization (NTA) are relatively small and would not be an important economic indicator.

#### Other organizations dealing with environmental issues

##### Ministry of Energy and Communication

This has relatively smaller financial resources and manpower compared with the Ministries mentioned previously.

The Central Electricity Board, Mauritius Marine Authority (also responsible for maintenance and operation of Port Louis harbour) and the Telecommunications Department, fall under the purview of the above Ministry.

##### Ministry of Local Government and Regional Administration

The five Municipalities (Port Louis, Beau Bassin/Rose Hill, Quatre Bornes, Curepipe, Vacoas/Phoenix) and the three District Councils (Grand Port-Savanne, Moka/Flacq, Pamplémousses/Rivière du Rempart), fall under the central administration of this Ministry. It must be noted that it is expected to undergo important changes in the near future. The Government has now set up a relatively high-level Commission (Bhuckory Commission) which aims to propose major improvements in local government.

## Meteorological Department

Considering the important role of climatology in environmental considerations, especially in the coastal zone (forecast of sea conditions, etc.), the functions, objectives and projects of this Department are hereby explained. The Department is under the purview of the Prime Minister's Office.

### Functions

The general functions of the Meteorological Department are:

- (a) Provision of meteorological services for:
  - government departments, local authorities, the press and general public and agricultural and industrial interests;
  - maritime and aeronautical navigation.
- (b) Organisation of meteorological observations in Mauritius and its Dependencies and over adjacent parts of the Indian Ocean;
- (c) Collection, distribution and publication of meteorological observations;
- (d) Provision of a tropical cyclone warning service for Mauritius and its Dependencies, for ships, aircraft and neighboring countries;
- (e) Participation in the activities of appropriate international organizations particularly the World Meteorological Organizations;
- (f) Research and investigations.

The Department also undertakes a limited amount of geophysical work. Magnetic observations are made at one station. It is of interest to note that the Meteorological Department is projecting the installation of mean sea-level recorders and improved devices to monitor sea-water temperatures and salinity.

### Departmental stations

The Department maintains the following stations:

- a meteorological station for surface and upper air observations at Vacoas, 20°18'S, 57°30'E, 425 m above mean sea-level; the administrative headquarters, main forecasting office and cyclone warning centre are also at this station;
- a first-order meteorological station, a supplementary forecasting centre and geomagnetic station at Plaisance International Airport, 20°26'S, 57°40'E, 57 m above sea-level;
- three meteorological and wireless transmitting and receiving stations in the Dependencies, namely, one at Agalega, 10°26'S, 56°45'E, at 3 m above mean sea-level, one at Rodrigues, 19°41'S, 63°25'E, at 59 m, and one at St. Brandon (Cargados Carajos) 16°27'S, 59°37'E, at 4 m. These stations also carry out measurements of upper winds by means of pilot balloons and theodolite;

- the Diego Garcia Meteorological Station which is now under the total responsibility of the United States Naval Authorities. However, the station remains in the Mauritius national network and observations from the station are received at Vacoas every three hours for global dissemination; (on behalf of the London Royal Society, a once daily radio link was maintained with the island of Aldabra for the purpose of passing meteorological observations and routine administrative messages;)
- a meteorological station for wind, rainfall, temperature and sea observations at the lookout tower in Port Louis Harbour which is also the local centre for meteorological liaison work with ships; a station for wind, barometric pressure, rainfall and sea observations at the lighthouse at Flat Island is operational, sending three-hourly observations during local cyclone periods - more frequently when the cyclones begin to interest Mauritius directly.

#### Other stations

Rainfall is measured at 245 rainfall stations maintained by government departments, sugar estates and other authorities. Duration of sunshine is recorded at 18 stations. Wind records are made at Pamplémousses, Mauritius Sugar Industry Research Institute Field Station and St. Antoine Sugar Estate in the north, at Médine Sugar Estate in the west and at Union Flacq Sugar Estate in the east. The department maintains anemometers at its stations at Plaisance, Vacoas, Port Louis Harbour and Flat Island. Anemometer records from Mon Désert Alma Sugar Estate and Bigara (H.M.S. Mauritius) are also analysed by the Department. Agro-meteorological stations are operated at Pamplémousses, Belle Rive, Union Park, Réduit and St. Antoine in Mauritius and at Le Maréchal in the south-west of Rodrigues.

#### Financial resources

Expenditure voted for 1982-83 was Rs. 5,250,000.00. The capital budget was Rs. 600,010.00.

#### Manpower

Total manpower: about 130; professional staff: about 50.

Listed below are the main (officially and 'semi-officially' recognized) organizations concerned with environmental issues:

1. University of Mauritius: parastatal body under Ministry of Education concerned to a certain extent with environmental education at primary school and secondary school level;
2. Central Water Authority: parastatal body under the Ministry of Energy and Telecommunications; its functions are as follows:
  - (a) To investigate water resources and to collect, correlate and interpret any data with regard to those resources;
  - (b) To prepare an inventory of water resources and to keep it continuously up to date;

- (c) To study and formulate policy in relation to the control and use of water resources for the following purposes:
- the provision of water resources for domestic, industrial and commercial supply and for hydro-electric power;
  - irrigation, land drainage, the reclamation of land, flood control, the development of fisheries, the protection of wild life, afforestation and the control of soil erosion;
  - the disposal of sewage and industrial waste;
  - the abatement and prevention of pollution of water resources;
  - any other purposes ancillary to the purposes specified in the sub-paragraphs above or such other purpose as the Authority may, with the approval of the Minister, determine.
- (d) To prepare plans for the conservation, utilization, control and development of water resources;
- (e) To prepare schemes for the development of river and transriver basins;
- (f) To co-ordinate and scrutinize the projects undertaken by any person relating to the conservation, utilization and development of water resources and to assess the technical possibilities, benefits and economic feasibility of the projects;
- (g) To conduct and co-ordinate research/investigation on the economic use of water;
- (h) To promote, design, construct, operate and maintain schemes and works for the purpose of conservation and development of water resources and for the purposes specified in paragraph (c);
- (i) To inspect any work carried out in relation to water development or utilization purposes;
- (j) To ensure that water supply conforms with such standards as are laid down by law;
- (k) To grant rights for the use of water and to issue permits, licences and concessions and, for this purpose, to:
- establish procedures for the recognition of existing water rights, for the re-assessment, variation and re-allocation of existing water rights and for the grant of new water rights;
  - establish procedures for the issue of permits, licences and concessions;
- (l) To supervise the enforcement of any water legislation;
- (m) To advise the Minister on any matter affecting water;

The act further purported to vest in the Authority on the appointed day:

- the Water Development branch and the Sewerage branch of the Ministry of Works;
- the Water Supply undertaking of the municipality of Port Louis;
- the undertaking of the Plaines Wilhems Sewerage Board.

3. Mauritius Institute (under the Ministry of Arts and of Cultural Affairs and Leisure): The Institute comprises a museum (the principal one on the island) and a library equipped with valuable reference material.
4. Mauritius Sugar Industry Research Institute: The Institute is of national importance and is fully concerned with research in sugar-cane and a few other crops which are of national importance in terms of local consumption and/or for export. The institute is partly financed by sugar-cane planters who contribute pro-rata according to the tonnage of sugar-cane harvested. The Government also makes a certain contribution to the Institute.

Ministry of External Affairs, Tourism and Emigration (tourism is dealt with later in the report)

#### Non-governmental organizations (NGOs)

- Mauritius Underwater Group (MUG);
- Mauritius Marine Conservation Society (MMCS);
- Rotary Club (Port Louis);
- Various Youth Movements, including The Federation of Young Farmers;
- Action Civique; one achievement of this organization has been the placing of litter bins, marked 'Keep Mauritius Clean', in strategic points in the urban areas.

### URBAN AND RURAL DEVELOPMENT

#### Major coastal cities, human settlements

##### Port Louis harbour

Port Louis harbour, the gateway to Mauritius, is the only harbour which provides terminal facilities and services to shipping. It plays a vital role in the economic and social development of Mauritius. The commercial facilities are concentrated in the city of Port Louis which is also the principal trading centre of the island. Situated in the north-west of the island it has an excellent port protected from the prevailing south-east trade winds by the mountains.

The number of vessels entering Port Louis harbour during the first and second quarter of 1982 has been estimated at about 240, the net registered tonnage (thousand tonnes) being about 1,375.

The number of vessels leaving the harbour during the same period was about 230, the net registered tonnage being estimated at 1,350.

##### (a) Port facilities

Port Louis harbour provides a wide range of cargo handling and harbour facilities and services. Since the establishment of the Mauritius Marine Authority, the port has continued to increase its capacity to cater for rising demand. The port has 672 metres of aligned deep water quays with depths ranging from 10.7 metres to 13 metres for containerized and conventional traffic. The port has also responded to worldwide technological changes in maritime transportation and cargo handling systems. The various facilities are as follows:

(b) Berthing facilities and services

1. Alongside deep water facilities

Quay	Length	Draft	Cargo handled
Quay 1	123 metres	11.00 metres	Bulk cargo/fertilizer
Quay 2	183 metres	10.70 metres	General cargo
Quay 3	183 metres	10.70 metres	General cargo
Quay 4 (Container terminal)	183 metres	10.70 metres	Containers
Quay D	150 metres	9.45 metres	Containers & liquid bulk cargo
Quay C	119 metres	5.50 metres	Inter island trade

2. Lighterage facilities

Quay	Length	Draft	Remarks
Quay A	190 metres	3.66 metres )	These quays are used for handling of cargo from lighters
Quay C	133 metres	3.04 metres )	
Quay E	134 metres	3.04 metres )	

3. Buoy berths

There are 10 buoy berths available and they are occasionally used to accommodate vessels for lighterage operation.

4. Cement berth

There is also a cement berth between Quays 1 and 2 for the bulk discharge of cement. Bulk cement is pumped at the rate of 400 tonnes per hour into silos sited near the quay.

5. Bulk sugar terminal

The bulk sugar terminal came into operation in July 1980. Sugar is loaded at a maximum rate of 1,400 tonnes per hour. Vessels up to 198 metres overall length and 11 metres draft can be accommodated. Two sheds with storage capacity of 175,000 tonnes of bulk sugar each are available.

(c) Cargo handling

The MMA is responsible for all cargo handling activities in the port. However, cargo handling operations are undertaken by Consolidated Cargo Services (Mtius) Ltd., a private company operating under the Authority's supervision and control. The Authority's transit storage areas have expanded significantly with recent developments. The total area of covered space now available for storage purposes is approximately 130,000 m<sup>2</sup>.

In addition to conventional facilities, the port has also provided specialized facilities for the handling of bulk and containerized cargo. An important fleet of sophisticated cargo handling equipment comprising heavy duty forklift trucks, auto trucks, mobile cranes, heavy duty tractors, trailers and prime movers are owned and operated by the MMA for cargo handling in the port.

(d) Pilotage

Pilotage is compulsory for all vessels over 100 NRT entering and leaving the Port. Pilotage services are provided by the Authority at any time during the day or night provided appropriate arrangements are made. The Authority owns a fleet of tugs and small craft for pilotage and associated operations.

(e) Cargo traffic

Cargo traffic at Port Louis, which is closely linked to industrial demand, has grown steadily over the past years. Port traffic increased from 1.51 million tonnes in 1971 to 1.77 million tonnes in 1973 and to approximately 2.0 million tonnes in 1980. Container traffic recorded a substantial increase during 1980; it is anticipated that with this trend, total container traffic might reach around 33,000 TEUs by 1983. The Authority is making every endeavour to promote containerization and to meet the demands of the revolutionary changes taking place in maritime transportation.

(f) Port development

The first phase of the port development culminated in the commissioning of the new deep water quays 2, 3 and 4 together with the back-up facilities. Quays No. 2 and 3 are used for unitized cargo operations. Quay No. 4, the container terminal, is used exclusively for the handling of containers. The annual throughput of the laden container park adjacent to quay No. 4 varies between 14,500 TEUs (with 2-high stacking) and 22,800 TEUs (3-high stacking).

A modern port administration building, workshop and fire station are under construction. Several other projects, including the construction of a recruitment centre, are in different stages of implementation. One of the striking features of Port Louis harbour is the availability of a vast area of land for future port development and expansion.

City of Port Louis (capital of the island)

Estimated population as at June 1982: 147,599 (no account has been taken of internal migration).

Recently, certain sections of 'suburbs' lying just outside the centre of the capital have been annexed to the city. These annexed areas now fall under the responsibility of the City Municipality. Population figures, the size (area) of the city, public health facilities, the sanitation and water supply situation, can only be indicated generally or approximately.

The present Population Census will certainly provide reliable, up-to-date figures on the actual size of the city. The Census was expected to be completed by mid-1984.

Table 3: The estimated population of Mauritius by geographical district and sex

Geographical district	Area in km <sup>2</sup>	P o p u l a t i o n											
		30 June 1980		30 June 1981		30 June 1982		30 June 1980		30 June 1981		30 June 1982	
		Both sexes	Male	Female	Both sexes	Male	Female	Both sexes	Male	Female	Both sexes	Male	Female
Port Louis	26.5	145,817	70,526	75,291	146,844	70,842	76,002	147,599	71,289	76,310	147,599	71,289	76,310
Pamplemousses	111	78,767	39,247	39,520	80,215	39,844	40,371	81,352	40,397	40,955	81,352	40,397	40,955
Rivière du Rempart	91	77,401	38,557	38,844	78,871	39,197	39,674	79,957	39,780	40,177	79,957	39,780	40,177
Flacq	185	103,781	51,496	52,285	105,706	52,348	53,358	107,209	53,095	54,114	107,209	53,095	54,114
Grand Port	162	90,918	44,971	45,947	92,192	45,449	46,743	93,318	46,032	47,286	93,318	46,032	47,286
Savanne	152	59,374	29,403	29,971	60,290	29,767	30,523	60,989	30,139	30,850	60,989	30,139	30,850
Plaines Wilhems	126	285,163	138,679	146,484	288,602	139,576	149,026	291,388	141,237	150,151	291,388	141,237	150,151
Moka	143	54,837	27,075	27,762	55,705	27,437	28,268	56,335	27,754	28,581	56,335	27,754	28,581
Black River	160	30,520	15,077	15,443	31,052	15,215	15,837	31,539	15,463	16,076	31,539	15,463	16,076
Island of Mauritius	1158	926,578	455,031	471,547	939,477	459,675	479,802	949,686	465,186	484,500	949,686	465,186	484,500
Island of Rodrigues	64	30,275	14,612	15,663	31,799	15,435	16,364	33,649	16,450	17,199	33,649	16,450	17,199
Other islands	44	350	250	100	350	250	100	350	250	100	350	250	100
Mauritius	1267	957,203	469,893	487,310	971,626	475,360	496,266	983,685	481,886	501,799	983,685	481,886	501,799



The main central market, part of which was recently burnt down, is at present in a poor state. The Municipality is still trying to raise the funds to construct a proper market place. Financial constraint is currently the major problem of the City Municipality.

UNEP, FAO and various other United Nations organizations have published ample descriptions and data on Port Louis which will not be repeated in this report.

It is worth noting that the problems of sanitation and refuse disposal are being steadily tackled by the municipal services and certain improvements have been achieved. For example, the construction of a water reservoir (recently completed) has almost solved the water supply problems of a housing estate (that forms part of the city) comprising about 2,000 inhabitants.

The two main bus termini still badly need improvement, the constraints being economic. The traffic authorities have, over the past 18 months or so, re-organized traffic flow in several parts of the city; one-way streets, no-parking zones, set hours for the delivery of goods by heavy vehicles, and additional police traffic-control during peak periods. However, in the long run, the solution to the traffic congestion problem, and other problems associated with the population concentration in and around Port Louis, will require a policy of decentralization.

On the whole, although the city still contains a few eye-sores, various marked improvements have taken place. A major problem is the need to improve the state of commercial buildings, many of which present incongruous facades along the pavements. Like many cities, Port Louis was never planned and grew into its present state since the old colonial days.

#### Sewerage facilities

The sewerage system in Port Louis is the oldest in the island. Major works have been carried out at various times - notably in the 1920s and 1980s. Major investments date from the mid-sixties, priority having been accorded to Port Louis in the light of the disposal problems of the north-east of the city and also the need to develop industrial estates.

An overview of the staging of the Port Louis development is given below:

Stage I 1965 - 1971	Construction of new northern interceptor sewer, northern works pumping station and sea outfall into the area of Fort George. A new sewer in the Fanfaron Stream Valley, new Fanfaron pumping station and sea outfall.
Stage II early seventies	Plaine Verte trunk sewer and reticulation; Plaine Lauzun reticulation system; Pouce Valley trunk sewer and reticulation system; Southern interceptor sewer; New Caudan pumping station and rising main; Southern Works: pumping station and sea outfall.
Stage III mid-seventies	To date: northern drainage zone industrial and residential estates; treatment plants.

The final phase of the Stage III development of Port Louis has just been concluded, with the completion of the MS 13 contract involving a major trunk sewer and reticulation sewers. The capacity of the Northern Sewage treatment plant has been doubled. With an additional capacity of 40,000 the new total capacity is 135,000. Tenders have been received for the improvement of infrastructural facilities including sewerage to four major C.H.C. estates in Port Louis under the Saudi-funded component of the Urban Rehabilitation Project. This project would, when implemented, improve the sewerage facilities of 2,000 families immediately and, eventually, altogether 3,000 families.

Public health facilities in Mauritius are indicated in map 5.

Table 4: Health services of Mauritius, 1977-1981 (as at 31 December)  
(Source: Statistics Digest)

	1977	1978	1979	1980	1981
<b>Hospitals</b>					
General hospitals	6	6	7	7	7
Specialized hospitals (psychiatric, leper, chest, eye and E.N.T.)	5	5	5	5	5
Prisons hospitals	2	2	1	1	2
Private hospitals on sugar estates	18	18	17	11	7
Health Centre	-	-	1	1	3
<b>Dispensaries</b>					
Public dispensaries (excluding health centres)	48	50	48	51	51
Prisons dispensaries	2	2	2	2	2
Private dispensaries on sugar estates	18	18	19	24	24
Mobile dispensaries	5	5	5	5	5
<b>Clinics</b>					
Dental	9	9	10	10	12
Social hygiene	1	1	1	1	1
Private	6	6	6	7	7
Public mobile ante-natal and family planning	1	1	1	1	1
Public mobile dental	2	2	2	2	2
Maternal and child health and family planning clinics (excluding health centres)	70	72	71	71	68
Family planning (only)					
Clinics	15	14	18	15	17
Supply centres	41	42	37	29	31
<b>Personnel (including Rodrigues)</b>					
<b>Doctors</b>					
Total government doctors	280	305	324	338	340
- of which specialists	102	102	104	104	114
Doctors in private practice	96	114	133	165	222
<b>Dentists</b>					
Government service	18	20	18	22	23
Private	27	26	35	37	46
<b>Pharmacists</b>					
Government services	8	7	7	7	6
Private	48	52	57	62	67
<b>Qualified nurses (excluding nurse-midwives)</b>					
Government service	1,130	1,269	1,309	1,440	1,458
<b>Qualified midwives/nurse-midwives</b>					
Government service	457	479	505	550	569

Mahébourg with its large concentration of population and administrative and commercial activities is the Regional Centre of the south. In view of its historic importance, and its present status as a coastal human settlement, a comprehensive study of this region has been written entitled Cahier No. 9: Monographies, by MATIM & The Ministry of Housing, Lands and Town and Country Planning (1976) which was appended to this report. Unfortunately limitations of space have precluded its reproduction here.

#### COASTAL INDUSTRIAL DEVELOPMENT

Tables 1 and 2 have listed the main industries in the island and the estimated population working in the various sectors. No information is yet available to indicate whether industries are national or foreign owned. No special complexes (OTEC, desalination etc.) exist in Mauritius.

Effluents: Salient features regarding effluents have also been given in section 1 under the headings "Sites and outflow of the rivers at the coast" and "Land-based sources of pollution".

Much additional information on both industries and effluents was appended to the study but regrettably it was too long and detailed to reproduce in this volume.

#### COASTAL AND INLAND HYDROPOWER AND WATER WORKS

There is at present only one major inland hydropower installation being carried out in the island. No such activities of any importance are to be found along the coast.

##### Champagne hydro-electric power station

The construction of this power station is well under way and expected to start operating in a year or two. The station, which will have an installed capacity of about 30 MW, will tap water from Grande Rivière South East, the flow of which will be considerably reduced (by about 50 to 75 per cent). The 3 km power tunnel will divert water to another river. The impact on the coast has not yet been formally assessed.

Public health aspects: The cavities left after the exploitation of sand quarries along the coast are generally levelled off and/or refilled to prevent the formation of pools of water which could breed malaria vectors (there has been a recrudescence of malaria in the island: over 500 cases last year).

#### TRANSPORT

The prevalent transport modes are buses, lorries, taxis and private cars. The coastal zone around the island is served by a good network of reasonably well-maintained roads. In the late 1960s, Mauritius had some 975 km of tarred roads; of these, 545 km were main roads and 430 km were tarred rural roads. By 1978, the

length of the tarred road network reached 1,770 km, made up of 545 km of main roads and some 1,225 km of urban and rural roads. This gives a road density of 0.95 km per km<sup>2</sup>, which is one of the highest in the world. As already mentioned, the relatively small size of the island makes it difficult to distinguish between coastal zone and inland zone data.

Some indications and trends of transactions in the port (Port Louis harbour) have already been given in section 2 under the heading "Major coastal cities". Additional information is to be found in table 5 below. Transport of people and goods (locally) along coastal waters is non-existent.

Table 5: Sea-borne shipping 1978 - 1982 <sup>a/</sup>

Period	Vessels entering		Vessels leaving		G o o d s	
	Number	Net registered tonnage (thousand tonnes)	Number	Net registered tonnage (thousand tonnes)	Unloaded (thousand tonnes)	Loaded <sup>b/</sup> (thousand tonnes)
1978	521	2,109	495	1,986	1,063	760
1979	520	2,320	502	2,391	1,140	853
1980	556	2,305	574	2,431	1,189	836
1981	545	2,559	530	2,609	909	546
1981: 1st Qr.	146	585	109	650	231	153
2nd Qr.	137	582	150	558	212	54
3rd Qr.	135	680	147	705	266	194
4th Qr.	127	712	124	696	200	145
1982 <sup>c/</sup> 1st Qr.	124	663	116	683	177	188
2nd Qr.	118	716	114	675	171	148

<sup>a/</sup> excluding fishing vessels berthed in Port Louis  
<sup>b/</sup> excluding bunkers  
<sup>c/</sup> provisional

Table 6: Civil Aviation Centre 1978 - 1982

P e r i o d	Number of movements		F r e i g h t	
	Landings	Take-offs	Unloaded (tonnes)	Loaded (tonnes)
1978	2,308	2,308	2,375.7	4,371.3
1979	2,816	2,816	3,749.5	4,060.4
1980	3,412	3,412	2,977.8	4,396.8
1981	3,196	3,196	3,041.1	4,200.4
1981 : 1st Qr.	753	753	637.2	739.7
2nd Qr.	782	782	1,000.7	953.2
3rd Qr.	867	867	709.7	1,198.9
4th Qr.	794	794	693.5	1,308.6
1982 : 1st Qr.	826	827	622.7	811.7
2nd Qr.	848	848	578.0	808.6

N.B The following points are relevant to this table:

- only movements of commercial aircraft are accounted for;
- each touch down or each take off is counted as a separate movement;
- freight carried by planes other than commercial is included.

#### EXPLOITATION OF TERRESTRIAL BIOLOGICAL RESOURCES

Most of the statistical breakdowns for the coastal zone only are at present not readily available. However, the "Land Resources and Agricultural Suitability Map of Mauritius" prepared by FAO and the Mauritius Sugar Industry Research Institute (May 1973), separately annexed to the present study but unfortunately too large to reproduce here, together with map 6, would serve as a rough guideline for the above assessment.

Statistics on the imports of fertilizers are provided in table 7, while statistics of harvest, sale and export of terrestrial resources, especially sugar, are amply laid out in a set of 28 tables. (Source: Annual Report of the Mauritius Chamber of Commerce, 1981-82), again, too long unfortunately to reproduce here.

#### Pesticides statistics



There is a Pesticides Management Advisory Committee in Mauritius, chaired by the Ministry of Agriculture, Fisheries and Natural Resources. It has the following terms of references:

- to ensure that pesticides entering Mauritius are those that have been tested and approved in the country of origin;
- to continually carry out national surveys on the use of pesticides;
- to organize tests of pesticide residues;
- to list and update restricted pesticides;
- to collect and compile data on pesticide imports;
- other related matters.

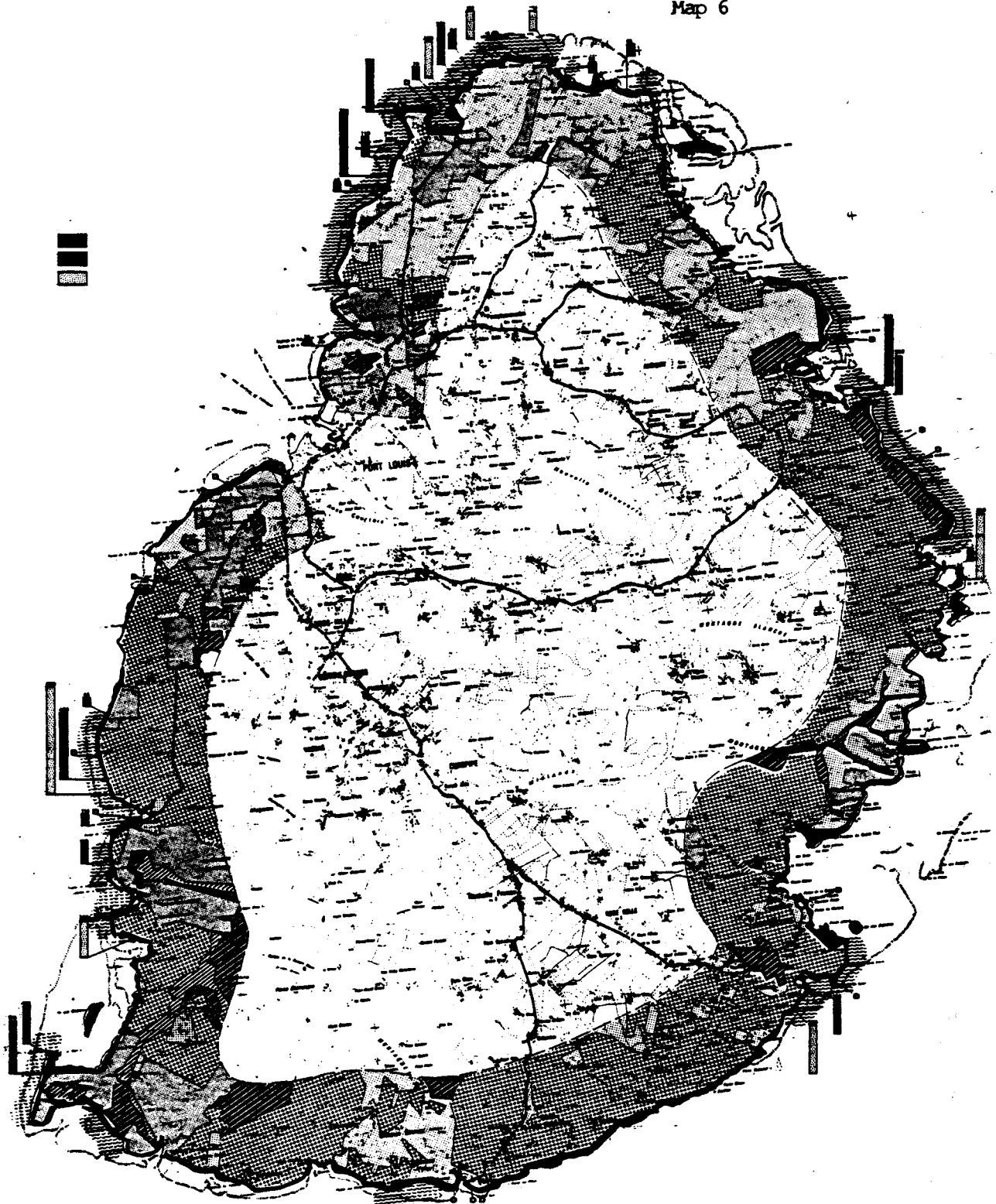



Map 6



**GOVERNMENT LANDS**

-  sea geomorphics
-  crown lands

**PRIVATE LANDS**

-  government reserves
-  sugar estates
-  planters with more than 1000 acres
-  " " less " " "

**BASE PLAN**

- lots:  1/2 of lots
- lots:  1/2 lots
- lots:  existing
- lots:  construction approved

**COAST FRONTAGE DATA :**





-  sea geomorphics sea frontage
-  private sea frontage
-  coral reef
-  good quality beaches

Table 7: Imports of fertilizers 1980 - 1982 <sup>a/</sup>

Kind of fertilizer	1	9	8	0	1	9	8	1	Jan.-Jun. 1982 <sup>c/</sup>	
	Quantity (tonnes)	Value (Rs.000)	Quantity (tonnes)	Value (Rs.000)	Quantity (tonnes)	Value (Rs.000)	Quantity (tonnes)	Value (Rs.000)	Quantity (tonnes)	Value (Rs.000)
Total imports	37,811	44,954	47,747	73,136	18,531	24,190				
Nitrogenous fertilizers										
Sulphate of ammonia	5,419	6,612	10,428	13,988	6,010	6,708				
Ammonium sulphate nitrate	5,066	5,702	10,261	13,500	6,000	6,633				
Other nitrogenous fertilizers	-	-	-	-	-	-				
Other nitrogenous fertilizers	353	910	167	488	10	75				
Potassic fertilizers										
Muriate of potash	22,702	24,971	23,198	32,010	11,262	15,722				
Sulphate of potash	22,094	23,587	22,565	30,246	10,751	14,254				
Other potassic fertilizers	600	1,287	400	1,015	500	1,430				
Other potassic fertilizers	8	97	233	749	11	38				
Phosphatic fertilizers										
Single superphosphate )	9,668	13,062	14,112	27,010	1,2501,584					
Triple superphosphate )	1,897	2,753	4,848	9,218	250	466				
Phosphatic guano	4,619	3,746	2,440	2,915	1,000	1,118				
Other	3,152	6,563	6,824	14,877	-	-				
Mixed and compound fertilizers	22	309	9	128	8	77				

a/ excluding imports from the islands of Agalega, St. Brandon and Rodrigues

b/ these two items merged in 1979

c/ provisional



Table 8: Imports (tonnes) of main pesticides in Mauritius 1970-81  
(C.I.F. value in M Rs - million Mauritian rupees)

Year	Insecticides		Fungicides		Herbicides		Total	
	Tonnes	M Rs	Tonnes	M Rs	Tonnes	M Rs	Tonnes	M Rs
1970	120.4	0.84	23.3	0.20	702.6	2.62	846.3	3.66
1971	131.9	0.88	42.9	0.38	528.8	2.92	703.6	4.18
1972	193.2	1.45	45.6	0.35	401.1	3.02	639.8	4.82
1973	150.9	1.23	60.1	0.44	463.1	4.32	674.1	5.99
1974	169.3	1.82	59.3	0.59	638.5	7.73	867.1	10.14
1975	192.8	3.29	63.9	0.96	530.5	10.08	787.1	14.33
1976	196.5	4.11	64.7	1.08	565.4	10.92	826.7	16.11
1977	398.5	5.93	55.8	0.80	591.3	9.09	1,045.5	15.82
1978	269.9	5.14	54.4	0.87	704.4	12.35	1,028.7	18.36
1979	392.0	8.94	106.3	2.18	680.7	14.14	1,179.0	25.25
1980	478.6	10.68	55.6	1.60	812.0	21.83	1,346.3	34.10
1981	251.8	7.66	94.0	2.43	635.2	22.53	980.9	32.62

Sources: Annual Report, Customs & Excise Department, Mauritius (1970 - 1978);  
Central Statistics Office (1979 - 1981).

#### FISHERIES

The information requested in the annotated outline on the fisheries situation in Mauritius is contained in the following documents;

- "Statistics - Fishing Industry" by D. Mauree and C.R. Samboo;
- "An Appraisal of the Banks Fishery in Mauritius" by C.R. Samboo;
- "Protection Service-Fisheries".

They were prepared with the collaboration of several Ministries and other organizations and appended to the report. However, limitations of space have precluded their reproduction in this volume.

An important step taken recently has been the banning of underwater spear gun fishing. A law was passed stating that all spearguns must now be surrendered to the authorities (Ministry of Agriculture, Fisheries and Natural Resources, and the police). As compensation to registered fishermen using spearguns, the Government offers Rs. 500 for every speargun handed over. So far, over 600 spearguns have been turned in. Import permits for spearguns are no longer granted.

Some general fisheries statistics (Bi-Annual Digest of Statistics, June 1982) are given below:

Source	1978	1979	1980	1981
	(tonnes)			
Lagoons & off-lagoons	2,356	2,345	1,635	1,600
Banks	2,825	1,857	1,405	1,473
Barachois & ponds	16	26	27	36

## MINERAL EXPLORATION AND EXPLOITATION

The only significant exploration and exploitation is that of coral sand along the coast. This is governed by the Removal of Sand Act which falls under the purview of the Ministry of Housing, Lands and the Environment.

The present heavy demand for building materials, including coral sand, is due to the following main aspects:

- an urgent need to repair existing infrastructures, including public and domestic buildings;
- the real and urgent need to provide housing for lower income groups, especially following extensive damage caused by recent cyclones;
- the projected housing estate developments and the necessity to set up further infrastructures so as to meet the requirements of a growing population.

The building industry is by far the main consumer of sand, although the Central Water Authority is also a significant user and requires about 10,000 tonnes annually for its filter beds at La Marie and Pailles. The present rate of use of sand in Mauritius is estimated at over 200,000 tonnes annually. Lack of records at the level of private sand quarries, the illegal removal of sand and various other problems do not allow more accurate estimates to be made. Sand is quarried from government sand quarries situated on crown lands, private sand quarries and from lagoon beds. The quarries along the coast have so far been heavily exploited. There is now a waiting list of about 50 to 60 persons who have applied for permission to remove sand from the seabed.

The Ministry of Housing, Lands and the Environment is finding it increasingly difficult to identify further suitable sites for exploitation as sand quarries (i.e. government sand quarries), and steps to stop the operation of all private sand quarries are also being contemplated. The Minister submitted a memorandum to Government on sand quarries in January 1983. The memorandum elucidated the present legal mechanism under the Sand Removal Act and the problems of control over sand quarries (and sand transportation) have also been spelled out.

Recent events have shown that, in spite of the provisions of the Act, the Ministry is unable to exercise a strict control on the unlawful removal of sand. Although the Minister of Housing is responsible for the implementation of the Act, the Conservator of Forests or police officers are also responsible for investigating the cargo of lorries and arresting, without a warrant, any driver suspected of the unlawful removal of sand. The services of the Conservator of Forests and the police have not been adequately applied in the control of illegal sand removal, especially since the Ministry has no patrolling staff under its auspices.

It is the feeling of the Ministry that the Development Works Corporation (a parastatal body) should be entrusted with the operation of sand quarries on crown land, especially to provide sand to Government and parastatal bodies. The Environment Division advises on strict conditions under which the removal should take place. Control of the quantity of sand removed is not well defined and the Ministry would co-operate in order to determine ways and means for the proper management and control of sand quarries.

With regard to private sand quarries, it is intended to withhold applications for the designation of sites and to consider the withdrawal of previous designations. However, all the legal implications of such a course of action are being looked into thoroughly before a decision is taken.

The possibility of the Development Works Corporation undertaking the removal, processing and distribution of sand to Government and parastatal bodies, bearing in mind the special requirements of the Central Water Authority (CWA) for a special grade of sand at a particular time, has been studied. The CWA and the Development Works Corporation have submitted joint reports.

Pending confirmation from the Development Works Corporation that it would be possible to process sand for CWA and a final decision on the question of sand in general, the following actions have been recommended:

- to allow CWA, on its own or through its successful tenderers for 1982-83, to remove 4,000 tonnes of badly needed sand from a site at Le Morne (south-west coast of the island);
- to request the Police and Forestry Service to control lorries carrying sand more often, with a view to detecting illegal removal, and to submit monthly reports for the Ministry's information;
- to request the Solicitor-General's Office to investigate whether, under the present legislation, private sand quarries can be controlled and to advise on amendments thereto if needed; and
- to set up a committee of officials under the aegis of the Ministry of Works in order to consider the use of substitutes for sand in the building industry and the financial implications of such a measures on the final costs of a building.

#### Removal of Sand Act

The Removal of Sand Act came into force on 15 October 1975. The Act provides for the designation of an area as a sand quarry as well as for sand landing places and regulates the transport and trade of sand. Some recommendations for the updating of the Act are now being considered and amongst other parties concerned, the Ministry of Housing, Lands and the Environment will also seek the views and advice of the Crown Law Office in this connection.

#### Government sand quarries

Under the Act, the Ministry has approved the designation of 21 sand quarries for the years 1975 to 1980, allocated on crown land. They are listed below. The total quantity of sand removed from these areas is 727,840 tonnes, and Rs. 7,669,802 have been collected (see table 9).

Table 9: Sale of sand at government sand quarries, 1975-1983

Sand quarry delivered (tonnes)	Quantity of sand (Rupees)	Amount collected
Beau Champ	197,907	1,979,070
Cap Malheureux	23,900	239,000
Belle Mare	175,396	1,996,705
Riambel	18,535	201,692
Palmar	279,639	2,796,390
Le Morne	10,000	150,000
Pomponette	20,463	306,945
<b>TOTAL</b>	<b>727,840</b>	<b>7,669,802</b>

List of government sand quarries designated for the period 1975-1980 (A = Arpent, roughly an acre)

A. Belle Mare (south-east coast)

No. 1 - 1A16 - October 1975  
 No. 2 - 1A04 - November 1975  
 No. 3 - 1A52 - January 1976  
 No. 4 - 0A79 -  
 No. 5 - 1A50 - April 1976  
 No. 6 - 2A00 - June 1980  
 No. 7 - 3A71 - September 1980

B. Palmar (south-east coast)

No. 1 - 1A94 - July 1976  
 No. 2 - 1A36 - October 1976  
 No. 3 - 1A08 - December 1976  
 No. 4 - 2A05 - February 1977  
 No. 5 - 2A00 - March 1977  
 No. 6 - 1A98 - August 1977  
 No. 7 - 3A90 - February 1979

C. Cap Malheureux (north coast)

- 1A70 - October 1975

D. Riambel (south coast)

- 1A51 - October 1975 (for supply to CWA only)

E. Beau Champ (Savanne) (south coast)

No.1 - 3A72 - March 1976  
 No.2 - 3A41 - July 1976  
 No.3 - 3A87 - February 1977  
 No.4 - 2A50 - May 1977  
 No.5 - 1A50 - August 1977

N.B: Out of the total island-wide annual consumption of about 200,000 tonnes, about 95,000 tonnes are removed from the seabed. No sand is exported.

### Private sand quarries

With regard to private sand quarries, a list of sites designated on the application of the interested parties is given in table 10. Of these, three sites are still in operation.

Table 10: Private sand quarries

Sites	Extent	Licence paid up to	Remarks
1. Wolmar		16 10 83	Undeclared sand quarry.
2. Pte. d'Esny	2A00	1 2 83	Designated sand quarry; still in operation.
3. St. Felix	22A84	25 10 83	Designated sand quarry; still in operation.
4. Roches Noires	5A00	4 6 83	Designated sand quarry is exhausted; 2nd site applied for not declared. Both sites now levelled and put to canes.
5. Pereybere	1A09	9 6 83	Designated sand quarry. Nearing completion.
6. Pereybere	4A17	18 3 80	Designated sand quarry is exhausted. Licence not been renewed. Site not refilled.
7. Pereybere		29 3 82	Undeclared sand quarry. Licence not renewed.
8. Beau Manguier	0A50	18 5 82	Sand quarry exhausted. Site being refilled. Licence not renewed.

### Illegal removal of sand

It is not possible to patrol the coastline of Mauritius on a 24-hour basis and for this reason the transport of sand is authorized only during the day. Police officers and forest officers who generally wear uniform should be in a position to control the transport of sand and arrest any driver suspected of illegal removal.

The requirements of the public will still be met by sand removed from the seabed in private sand quarries. With regard to the removal of sand from the seabed a first experiment by mechanical means has been a failure. In this respect a request has been made to the Ministry of Economic Planning and Development under a UNDP Scheme for a study to be undertaken to investigate, inter alia, the impact of removal of sand by mechanical means from lagoons and the seabed.

## TOURISM

The rapid growth of tourism in the last decade has made it the third largest foreign exchange earner for Mauritius. The Mauritian Government is constantly encouraging this sector through the provision of appropriate infrastructure, fiscal concessions and credit facilities. The tourism industry has steadily expanded from the 1970s and tourist arrivals have increased by an average of about 15 to 18 per cent annually, although there has been a slight levelling off during the past two or three years.

The total foreign exchange revenue from tourism last year was about three hundred million rupees. The number of hotels (luxury and semi-luxury) now stands at about 45, and the number of hotel rooms would be about 2,500. The total direct employment in the whole tourist sector is at present about 6,000. The staff employed in hotels and restaurants is about 3,000. Tables 11 and 12 provide further details on tourist arrivals.

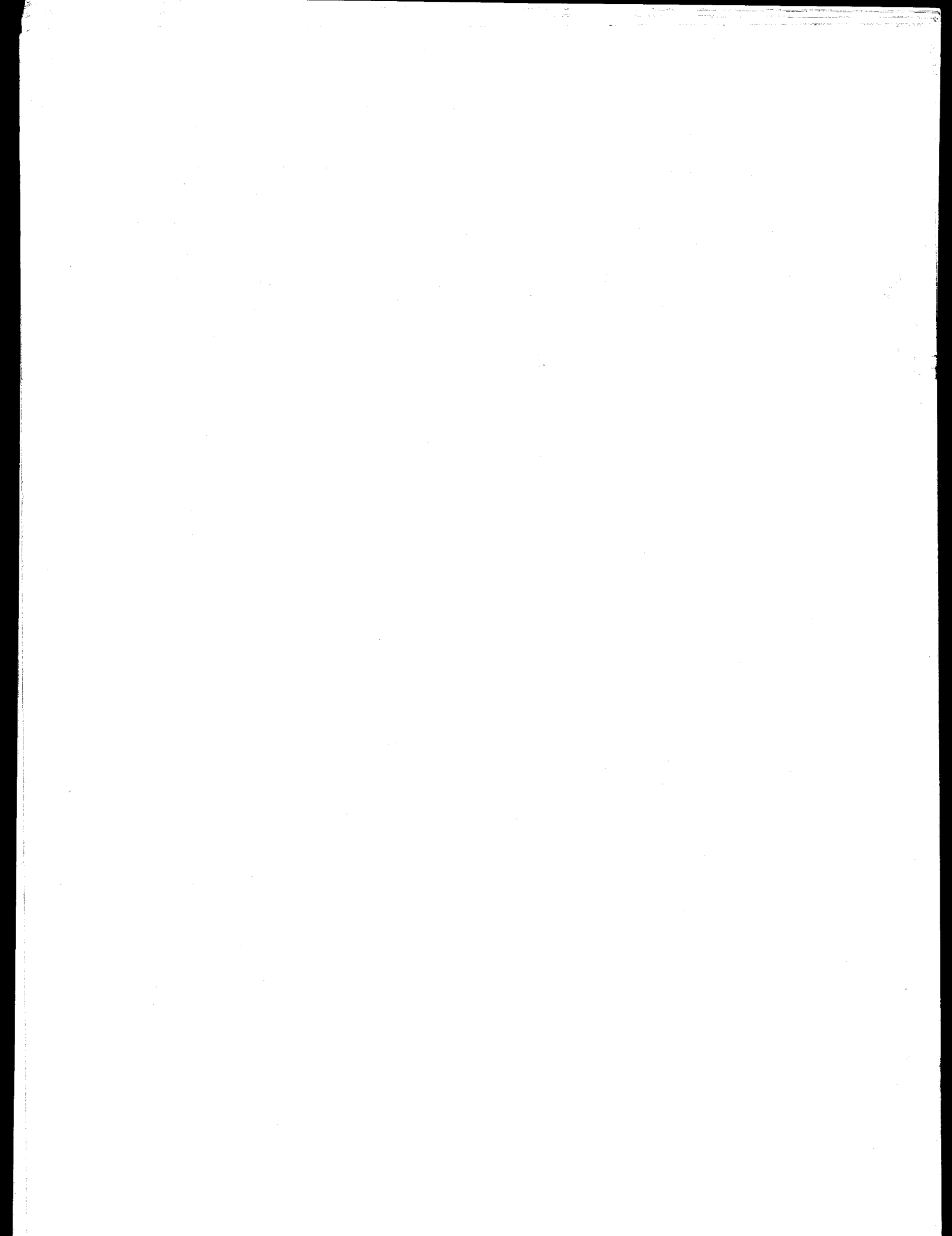

Table 11: Tourist arrivals and tourist nights by country of residence - Island of Mauritius, January - June 1982

Country of residence	Tourist arrivals	Tourist nights <sup>a/</sup>
Australia	1,250	13,150
France	8,460	100,640
Germany, Fed. Rep. of	3,520	60,080
India	1,110	15,090
Italy	3,340	38,190
Kenya	310	3,470
Malagasy Republic	3,050	21,040
Reunion	13,860	123,870
Zimbabwe	310	4,530
Seychelles	280	1,740
South Africa, Rep. of	11,150	105,350
Switzerland	600	11,320
Tanzania, United Republic of	290	1,750
United Kingdom	2,660	52,890
United States	490	8,650
Zambia	540	7,120
Other countries	3,260	38,500
All countries	54,480	607,380

<sup>a/</sup> Provisional: includes nights spent during January-June 1982 by tourists arriving prior to this period.

Table 12: Tourist <sup>a/</sup> arrivals by mode of transport and tourist nights spend during period 1965 - June 1982.

Period	Tourists arriving during period			Tourist nights spent during period <sup>b/</sup>	% change of	
	Sea	Air	Total		Tourist arrivals	Tourist nights
1965	746	9,312	10,058	144,900	+ 0.2	+ 0.2
1966	1,328	11,712	13,040	162,300	+ 29.6	+ 12.0
1967	937	13,877	14,814	172,000	+ 13.6	+ 6.0
1968	647	14,906	15,553	149,500	+ 5.0	- 13.1
1969	455	20,132	20,587	220,600	+ 32.4	+ 47.6
1970	365	27,285	27,650	287,600	+ 34.3	+ 30.4
1971	168	36,230	36,398	399,700	+ 31.6	+ 39.0
1972	143	48,654	48,797	454,300	+ 34.1	+ 13.7
1973	1,293 <sup>c/</sup>	66,701	67,994	733,100	+ 39.3	+ 61.4
1974	472	72,443	72,915	772,200	+ 7.2	+ 5.3
1975	554	74,043	74,597	746,900	+ 2.3	- 3.3
1976	778	91,783	92,561	892,200	+ 24.1	+ 19.4
1977	1,035	101,475	102,510	994,800	+ 10.7	+ 11.5
1978	696	107,626	108,322	1,051,600	+ 5.7	+ 5.7
1979	510	127,850	128,360	1,419,600	+ 18.5	+ 35.0
1980	470	114,610	115,080	1,301,700	- 10.4	- 8.3
1981	590	121,030	121,620	1,361,200	+ 5.7	+ 4.6
Jan-June 1982	270	54,210	54,480	607,400 <sup>d/</sup>	Not applicable	Not applicable

<sup>a/</sup> tourist is defined as a non-resident staying in the island for about a year  
<sup>b/</sup> include nights spent during reference period by tourists arriving prior to 1965  
<sup>c/</sup> include about 700 persons who came for a religious conference  
<sup>d/</sup> provisional



REFERENCES

Annuaire de l'Industrie Sucrière (1979-1980).

Annual Reports of the Central Electricity Board, Mauritius (1981) Annual Report and Accounts.

Annual Reports of the various Ministries in Mauritius.

Bi-annual Digest of Statistics (1982) - Vol.17, No.1, Ministry of Economic Planning & Development, Mauritius, Central Statistics Office.

Cahiers MATIM (1976-1977) Mission d'Aménagement du Territoire à l'Ile Maurice (Cahiers No. 1-15).

Central Water Authority - Hydrology Section (1978; 1979; 1980) Hydrology Year Book Published by the Authority of the Ministry of Fuel, Power and Energy.

FAO (1978) Land and Water Resources Survey Volumes 1 - VI (FAO/SF: 78/MAR6).

FAO/UNEP: Marine pollution in the East African region. UNEP Regional Seas Reports and Studies No. 8. UNEP 1982.

IMO/UNEP: Oil pollution control in the East African region. UNEP Regional Seas Reports and Studies No. 10. UNEP 1982.

International Mauritian Directory (1983) P.P.L. Editions.

IUCN/UNEP: Conservation of coastal and marine ecosystems and living resources of the East African region. UNEP Regional Seas Reports and Studies No. 11. UNEP 1982.

Mauritius Capital Budget (1982-83) with Memorandum as passed by the Legislative Assembly on 20 August 1982 and Draft Estimates with Memorandum.

Meteorological Services - Climate of Mauritius.

The Mauritius Institute Bulletins (1975,1976) Vol. VIII, Part 1 (1975) Part 2 (1976)

Two Year Plan (1980-82) for Economic and Social Development, Ministry of Economic Planning and Development.

UNEP: Environmental Problems of the East African Region. UNEP Regional Seas Reports and Studies No. 12. UNEP 1982.

UNEP: Report of the Workshop on the Protection and Development of the Marine and Coastal Environment of the East African Region, Mahé, 27 - 30 September 1982 (UNEP/WG/77/4).

UNIDO/UNEP: Industrial sources of marine and coastal pollution in the East African region. UNEP Regional Seas Reports and Studies No. 7. UNEP 1982.

UN/UNESCO/UNEP: Marine and coastal area development in the East African region. UNEP Regional Seas Reports and Studies No. 6. UNEP 1982.

UNEP: Public health problems in the coastal zone of the East African region. UNEP Regional Seas Reports and Studies No. 9. UNEP 1982.

DOCUMENTATION PROVIDED WITH REPORT

Annual Report of the Mauritius, Chamber of Agriculture (1981-1982) The President's report (pp. vi-xxxii).

Carte Touristique et Routière de l'Ile Maurice.

Domun, M.V.D. (1982) Soil Erosion in Mauritius - Investigations and Recommendations. Ministry of Agriculture, Natural Resources and the Environment.

FAO and Mauritius Sugar Industry Research Institute (1973) Land Resources and Agricultural Suitability Map of Mauritius.

Faure, G. (1981) Séminaire: Ressources Aquatiques - Préservation des Zones Côtières, Développement de la Pêche Côtière et de l'Aquaculture, Seychelles 11-16 mai. Centre Universitaire de la Réunion.

Jehangeer, M.I. (1978) The State of Aquatic Pollution in Mauritius, Sixth FAO/SIDA Workshop on Aquatic Pollution in Relation to Protection of Living Resources (FIR: TPLR/78/INF.28).

Lagoon Resource Exploration and Pollution.

Land Resources and Agricultural Suitability Map of Mauritius (1976)

List of Industries (upto 1983) Ministry of Commerce, Industry, Prices and Consumer Protection, Mauritius.

Mauree, D. and Samboo, C.R. (1981) Statistics - Fishing Industry.

Mauritius Marine Authority (1979) Cargo Statistics 1975-1978 (Appendix 1).

Memorandum on Drift of Herbicides.

Michel, C. (1974) Notes on Marine Biology. Mauritius Institute Bulletin, Vol.VII, Part II.

Ministry of Health - Memorandum.

Mission d'Aménagement du Territoire à l'Ile Maurice (1976) Mahébourg. Ministry of Housing, Lands and the Environment, Mauritius (Cahier No.9: Monographs 9.2.).

National Survey on the Perception and Management of Pests and Pesticides in Mauritius.

Padaruth, R.P. Projet de Mise au Point du Système Naturel d'Épuration des Eaux par Marais Reconstitué à l'Ile Maurice. Adaptation de cette Technologie aux Pays Tropicaux.

Patten, N. (1983) National Physical Development Planning, Ministry of Housing, Lands and the Environment, Mauritius.

Patten, N. (1983) Town and Country Planning: The Legal and Administrative Framework, Ministry of Housing, Lands and the Environment, Mauritius.

Population Census for Mauritius (1983) Night of 2 - 3 July.

Protection Service - Fishermen.

Ramyeed, T.S. (1980) Environmental Impact Statement, Ministry of Agriculture, National Resources and The Environment, Land Use and Environment Division (Parts I & II).

Ramyeed, T.S. (1980) Industrial Survey - Industries in Plaine Lazun, Ministry of Agriculture & Natural Resources and Environment, Land Use and Environment Division.

Ramyeed, T.S. (1981) Environmental Impact Assessment in Mauritius, Ministry of Agriculture and Natural Resources and the Environment, Land Use and Environment Division.

Ramyeed, T.S. (1981) Pollution by Industries: St Louis River (Case Study) Ministry of Housing, Lands and the Environment, Mauritius.

Ramyeed, T.S. (1982) Environmental Survey - Sugar Factory (Case Study) Ministry of Housing, Lands and the Environment, Mauritius.

Ramyeed, T.S. (1983) Preservation of the Environment. Ministry of Housing, Lands and the Environment, Mauritius.

Removal of Sand Act (1975) Arrangement of sections.

Samboo, C.R. (1983) An Appraisal of the Banks Fisheries. Ministry of Agriculture, Fisheries and Natural Resources (Report No.1 RD(F)/SU/83/1).

Towards Increasing Self-Reliance (1983) A Development Strategy Paper, Ministry of Economic Planning and Development, Mauritius.

United States Navy (1976) Marine climatic atlas of the world. Vol II. Indian Ocean.

Walker, H.J. (1962) Coral and the Lime Industry of Mauritius. The Geographical Review, Vol. LII, November 3.

Map 7

LEGEND

- cord reef
  - ⊙ existing fisheries control posts
  - ⊕ projected additional fisheries control posts
  - ⊙ fish landing stations where statistics are affected
  - ⊙ ponds for carps (government)
  - ⊙ ponds for carps (private)
  - ⊙ camaron hatchery (government)
  - ⊙ camaron hatchery (private)
  - ⊙ barachois (A) government  
(B) government leased out to private  
(C) private
  - ⊙ projected public aquarium
  - ▭ projected marine parks
  - ▨ fish reserves
  - ▩ salt pans
- SCALE: 1 : 100 000

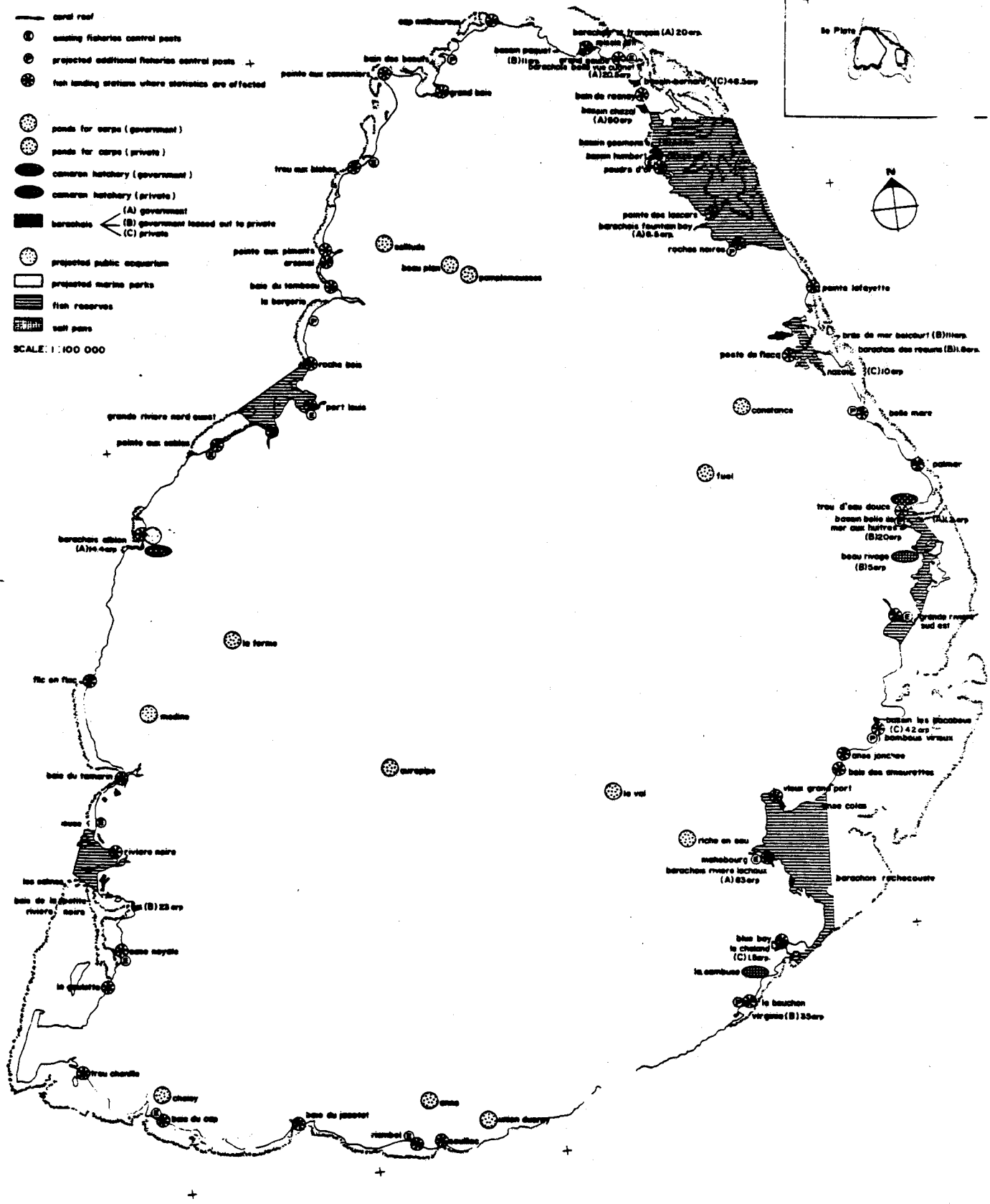
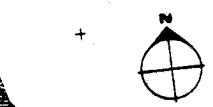
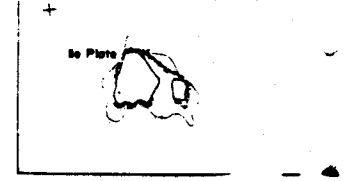

Map 8

**boreholes**

1. bois mangue
2. belle vue mauricia
3. plaines des papayes
4. st. andré
5. moulin à poudre
6. fond du sac
7. poudre d'or hamlet
8. poudre d'or
9. petite retraite
10. l'aventure
11. marre carree
12. bel air
13. belle rose
14. palmyre
15. beard
16. holyrood
17. st. paul
18. clairfonds
19. solferino
20. palma
21. le bosquet

**WATER SUPPLY**

- 1 mare aux vacoas system
- 2 districts system
- 3 port-louis system

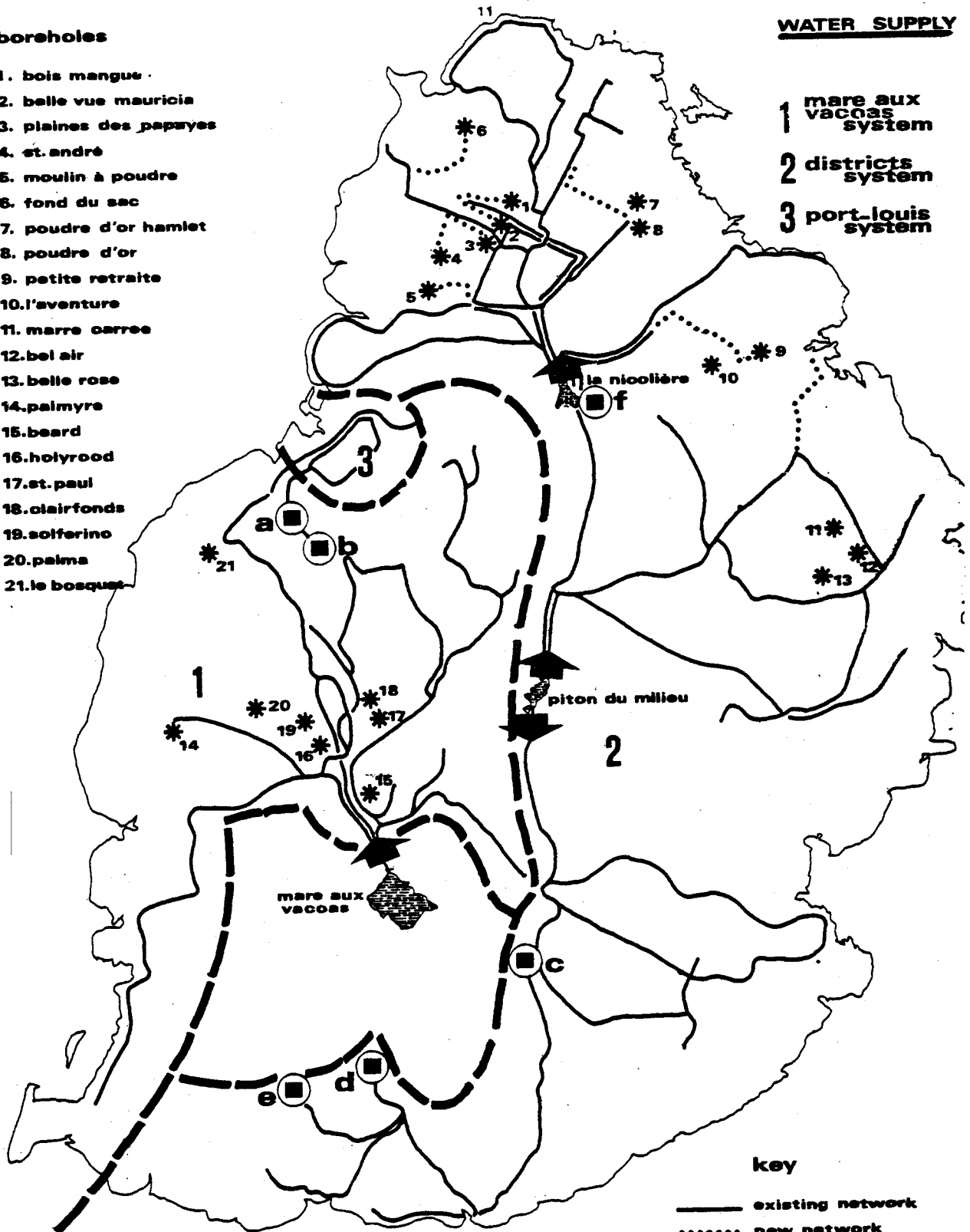

**river intake**

- a** g.r.n.w.
- b** rivière moka
- c** rivière du poste
- d** mont blanc
- e** rivière des galets

**key**

- existing network
- ..... new network
- \* boreholes
- ◻ river intake
- ◻ reservoir intake

1. The first part of the document is a list of names and addresses.

2. The second part of the document is a list of names and addresses.

3. The third part of the document is a list of names and addresses.

4. The fourth part of the document is a list of names and addresses.

5. The fifth part of the document is a list of names and addresses.

6. The sixth part of the document is a list of names and addresses.

7. The seventh part of the document is a list of names and addresses.

8. The eighth part of the document is a list of names and addresses.

9. The ninth part of the document is a list of names and addresses.

10. The tenth part of the document is a list of names and addresses.

11. The eleventh part of the document is a list of names and addresses.

12. The twelfth part of the document is a list of names and addresses.

13. The thirteenth part of the document is a list of names and addresses.

14. The fourteenth part of the document is a list of names and addresses.

15. The fifteenth part of the document is a list of names and addresses.

16. The sixteenth part of the document is a list of names and addresses.

17. The seventeenth part of the document is a list of names and addresses.

18. The eighteenth part of the document is a list of names and addresses.

19. The nineteenth part of the document is a list of names and addresses.

20. The twentieth part of the document is a list of names and addresses.

21. The twenty-first part of the document is a list of names and addresses.

22. The twenty-second part of the document is a list of names and addresses.

23. The twenty-third part of the document is a list of names and addresses.

24. The twenty-fourth part of the document is a list of names and addresses.

25. The twenty-fifth part of the document is a list of names and addresses.

26. The twenty-sixth part of the document is a list of names and addresses.

27. The twenty-seventh part of the document is a list of names and addresses.

28. The twenty-eighth part of the document is a list of names and addresses.

29. The twenty-ninth part of the document is a list of names and addresses.

30. The thirtieth part of the document is a list of names and addresses.

31. The thirty-first part of the document is a list of names and addresses.

32. The thirty-second part of the document is a list of names and addresses.

PUBLICATIONS DE LA SERIE DES RAPPORTS ET ETUDES DU PNUE  
SUR LES MERS REGIONALES

- No. 1 PNUE: Réalisations et projets d'extension du programme du PNUE pour les mers régionales et des programmes comparables relevant d'autres organismes. (1982)
- No. 2 ONUDI/PNUE: Etudes de polluants marins provenant de sources industrielles dans la région de l'Afrique de l'Ouest et du Centre. (1982)
- No. 3 UNESCO/PNUE: Les apports de polluants par les fleuves dans les eaux côtières de l'Afrique de l'Ouest et du Centre. (1982)
- No. 4 OMCI/PNUE: La pollution par les hydrocarbures dans la région de l'Afrique de l'Ouest et du Centre : état actuel et mesures à prendre. (1982)
- No. 5 IAEA/UNEP: Survey of tar, oil, chlorinated hydrocarbons and trace metal pollution in coastal waters of the Sultanate of Oman. (1982) (anglais seulement)
- No. 6 ONU/UNESCO/PNUE: Mise en valeur du milieu marin et des zones côtières dans la région de l'Afrique de l'Est. (1982)
- No. 7 ONUDI/PNUE: Sources industrielles de pollution des mers et des côtes dans la région de l'Afrique de l'Est. (1982)
- No. 8 FAO/PNUE: La pollution des mers dans la région de l'Afrique de l'Est. (1982)
- No. 9 OMS/PNUE: Problèmes de santé publique dans la zone côtière de la région de l'Afrique de l'Est. (1982)
- No. 10 OMI/PNUE: Lutte contre la pollution par les hydrocarbures dans la région de l'Afrique de l'Est. (1982)
- No. 11 UICN/PNUE: Conservation des écosystèmes et des ressources biologiques des mers et des côtes dans la région de l'Afrique de l'Est. (1982)
- No. 12 PNUE: Problèmes de l'environnement qui se posent dans la région de l'Afrique de l'Est. (1982)
- No. 13 UNEP: Pollution and the marine environment in the Indian Ocean. (1982) (anglais seulement)
- No. 14 PNUE/CEPAL: Développement et environnement dans la région des Caraïbes: une synthèse. (1982)
- No. 15 UNEP: Guidelines and principles for the preparation and implementation of comprehensive action plans for the protection and development of marine and coastal areas of regional seas. (1982) (anglais seulement)
- No. 16 GESAMP: The health of the oceans. (1982) (anglais seulement)
- No. 17 UNEP: Regional Seas Programme: Legislative authority. (1985) (anglais seulement)

- No. 18 UNEP: Regional Seas Programme: Workplan. (1982) (anglais seulement)
- No. 19 Rev. 2. UNEP: UNEP Oceans Programme: Compendium of projects. (1985) (anglais seulement)
- No. 20 CPPS/UNEP: Action Plan for the protection of the marine environment and coastal areas of the South-East Pacific. (1982) (anglais et espagnol seulement)
- No. 21 CPPS/PNUMA: Fuentes, niveles y efectos de la contaminación marina en el Pacífico Sudeste. (1982) (espagnol seulement)
- No. 22 Rev. 2. PNUE: Programme pour les mers régionales en Amérique Latine et dans la région des Caraïbes. (1985)
- No. 23 FAO/UNESCO/IOC/WHO/WMO/IAEA/UNEP: Co-ordinated Mediterranean Pollution Monitoring and Research Programme (MED POL) - Phase I: Programme Description. (1983) (anglais seulement)
- No. 24 UNEP: Action Plan for the protection and development of the marine and coastal areas of the East Asian Region. (1983) (anglais seulement)
- No. 25 PNUE: Pollution marine. (1984)
- No. 26 PNUE: Plan d'action pour le programme d'environnement des Caraïbes. (1983)
- No. 27 PNUE: Plan d'action pour la protection et la mise en valeur du milieu marin et des zones côtières de la Région de l'Afrique de l'Ouest et du Centre. (1983)
- No. 28 PNUE: Programme à long terme de surveillance continue et de recherche relatif au Plan d'action pour la Méditerranée (MED POL - Phase II). (1983)
- No. 29 CPS/SPEC/CESAP/PNUE: Plan d'action pour la gestion des ressources naturelles et de l'environnement du Pacifique Sud. (1983)
- No. 30 ONU-DAESI/PNUE: Potentiel énergétique de l'océan dans la région de l'Afrique de l'Ouest et du Centre. (1983)
- No. 31 A. L. Dahl et I. L. Baumgart: L'état de l'environnement dans le Pacifique Sud. (1983)
- No. 32 PNUE/CEE/ONUDI/FAO/UNESCO/OMS/AIEA: Les polluants d'origine tellurique en Méditerranée. (1984)
- No. 33 ONU-DAESI/PNUE: L'impact côtier des opérations d'exploitation du pétrole et du gaz en mer dans la région de l'Afrique de l'Ouest et du Centre. (1984)
- No. 34 PNUE: Plan d'action pour la protection et le développement de la région Méditerranéenne. (1984)
- No. 35 UNEP: Action Plan for the protection of the marine environment and the coastal areas of Bahrain, Iran, Iraq, Kuwait, Oman, Qatar, Saudi Arabia and the United Arab Emirates. (1983) (anglais seulement)
- No. 36 PNUE/CEPAL: L'état de la pollution marine dans la région des Caraïbes. (1984)



- No. 37 ONU-DAESI/PNUE: Problèmes de gestion de l'environnement liés à l'utilisation des ressources et inventaire des ressources de la région de l'Afrique de l'Ouest et du Centre. (1984)
- No. 38 FAO/PNUE: Aspects juridiques de la protection et de la gestion du milieu marin et côtier de la région de l'Afrique de l'Est. (1983)
- No. 39 PNUE: Conservation marine et côtière dans la région de l'Afrique de l'Est. (1984)
- No. 40 CPS/SPEC/CESAP/PNUE: Radioactivité dans le Pacifique du Sud. (1984)
- No. 41 PNUE: L'impact potentiel des activités socio-économiques sur l'environnement marin et côtier de la région de l'Afrique de l'Est. (1984)
- No. 42 GESAMP: Principles for developing coastal water quality criteria. (1984) (anglais seulement)
- No. 43 CPPS/UNEP: Contingency plan to combat oil pollution in the South-East Pacific in cases of emergency. (1984) (anglais et espagnol seulement)
- No. 44 IMO/ROPME/UNEP: Combating oil pollution in the Kuwait Action Plan region. (1984) (anglais seulement)
- No. 45 GESAMP: Thermal discharges in the marine environment. (1984) (anglais seulement)
- No. 46 UNEP: The marine and coastal environment of the West and Central African region and its state of pollution. (1984) (anglais seulement)
- No. 47 UNEP: Prospects for global ocean pollution monitoring. (1984) (anglais seulement)
- No. 48 CPS/SPEC/CESAP/PNUE: Le stockage et l'élimination des déchets dangereux dans le Pacifique Sud. (1984)
- No. 48/ Appendices SPC/SPEC/ESCAP/UNEP: Hazardous waste storage and disposal in the South Pacific. (1984) (anglais seulement)
- No. 49 FAO/PNUE: Aspects juridiques de la protection et de la gestion du milieu marin et côtier de la région de l'Afrique de l'Est : Rapports nationaux. (1984) (en langues originales, anglais et français)
- No. 50 UICN/PNUE: Conservation marine et côtière dans la région de l'Afrique de l'Est : Rapports nationaux. (1984) (en langues originales, anglais et français)
- No. 51 PNUE: L'impact potentiel des activités socio-économiques sur l'environnement marin et côtier de la région de l'Afrique de l'Est : Rapports nationaux. (1984) (en langues originales, anglais et français)
- No. 52 UNEP: Arab co-operation for the protection and development of the marine environment and coastal areas resources of the Mediterranean. (1984) (anglais seulement)

- No. 53 PNUE: Programme pour les mers régionales du PNUE : le cas de l'Afrique Orientale. (1984)
- No. 54 ONUDI/PNUE: Plans d'intervention en cas d'accidents industriels dans la région de l'Afrique de l'Ouest et du Centre. (1985)
- No. 55 FAO/PNUE: Mammifères marins: plan d'action mondial. (1985)
- No. 55/ Annex FAO/IUCN/IWC/UNEP: Marine mammals: global plan of action. (1985) (anglais seulement)
- No. 56 GESAMP: Cadmium, lead and tin in the marine environment. (1985) (anglais seulement)
- No. 57 OMI/PNUE: Pollution par pétrole et nettoyage du littoral des côtes de l'Afrique orientale. (1985)
- No. 58 UNEP: Co-operative programmes sponsored by UNEP for the protection of the marine and coastal environment in the wider Indian Ocean region. (anglais seulement) (1985)
- No. 59 UNEP: Environmental problems of the marine and coastal area of India: National Report. (1985) (anglais seulement)
- No. 60 UICN/PNUE: Gestion et conservation des ressources marines renouvelables dans la région de l'Océan Indien. (1985)
- No. 61 PNUE: Plan d'action pour la protection, la gestion et la mise en valeur du milieu marin et des zones côtières de la région de l'Afrique orientale. (1985)
- No. 62 UICN/PNUE: Management and conservation of renewable marine resources in the South Asian Seas region. (1985) (anglais seulement)
- No. 63 IUCN/UNEP: Management and conservation of renewable marine resources in the Kuwait Action Plan region. (1985) (anglais seulement)
- No. 64 IUCN/UNEP: Management and conservation of renewable marine resources in the Red Sea and Gulf of Aden region. (1985) (anglais seulement)
- No. 65 IUCN/UNEP: Management and conservation of renewable marine resources in the East Asian Seas region. (1985) (anglais seulement)
- No. 66 UICN/PNUE: Gestion et conservation des ressources marines renouvelables dans la région de l'Afrique Orientale. (1985)
- No. 67 ONU/PNUE: Erosion côtière en Afrique de l'Ouest et du Centre. (1985)
- No. 68 GESAMP: Atmospheric transport of contaminants into the Mediterranean region. (1985) (anglais seulement)
- No. 69 UNEP: Environment and resources in the Pacific. (1985) (anglais seulement)
- No. 70 UNESCO/ROPME/UPM: Proceedings of the Symposium/Workshop on oceanographic modelling of the Kuwait Action Plan (KAP) region. (1985) (anglais seulement)

- No. 71 IUCN/ROPME/UNEP: An ecological study of the rocky shores on the southern coast of Oman. (1985) (anglais seulement)
- No. 72 IUCN/ROPME/UNEP: An ecological study of sites on the coast of Bahrain. (1985) (anglais seulement)
- No. 73 SPC/SPEC/ESCAP/UNEP: Ecological interactions between tropical coastal ecosystems. (1985) (anglais seulement)

