

REDUCING MERCURY EXPOSURES AND TRANSITIONING MINERS AWAY FROM MERCURY USE

*Anglophone West Africa Regional Awareness-raising
Workshop On Mercury In Artisanal & Small Scale
Mining (ASGM)-Lagos, Nigeria, June 2011*

Haji Rehani



AGENDA
For **Environment** and Responsible Development

Presentation Outline

- **Part I: Reducing Mercury Emissions From Small Scale Gold Refining Facilities In Tanzania**
- **Part II: Transitioning Miners Away From Mercury Use**

Reducing Mercury Emissions From Small Scale Gold Refining Facilities In Tanzania

INTRODUCTION

- AGENDA is currently implementing a project **“Reducing Mercury Emissions From Small Scale Gold Refining Facilities In Tanzania”**
- The goal is to contribute into to reducing environmental pollution from mercury pollution by artisanal and small scale gold miners in Tanzania and hence associated health problems
- The objective is to create awareness on fume hood technology that reduces release into the environment and re-use of the mercury that is used to recover fine gold from artisanal and small scale gold miners

Introduction.....

The project is implemented by:

- Conducting training of trainers to small scale miners, gold brokers, Mining Officers and key Government Officials on fume hood technology;
- Awareness raising to gold shop owners, small scale miners and general public on impacts of mercury to human health and the environment through media;



FUME HOOD CONDENSER TECHNOLOGY

- Minimising mercury release on the environment and exposure risks by encourage brokers install fume hood and encourage miners to burn their amalgam at brokers place/shops

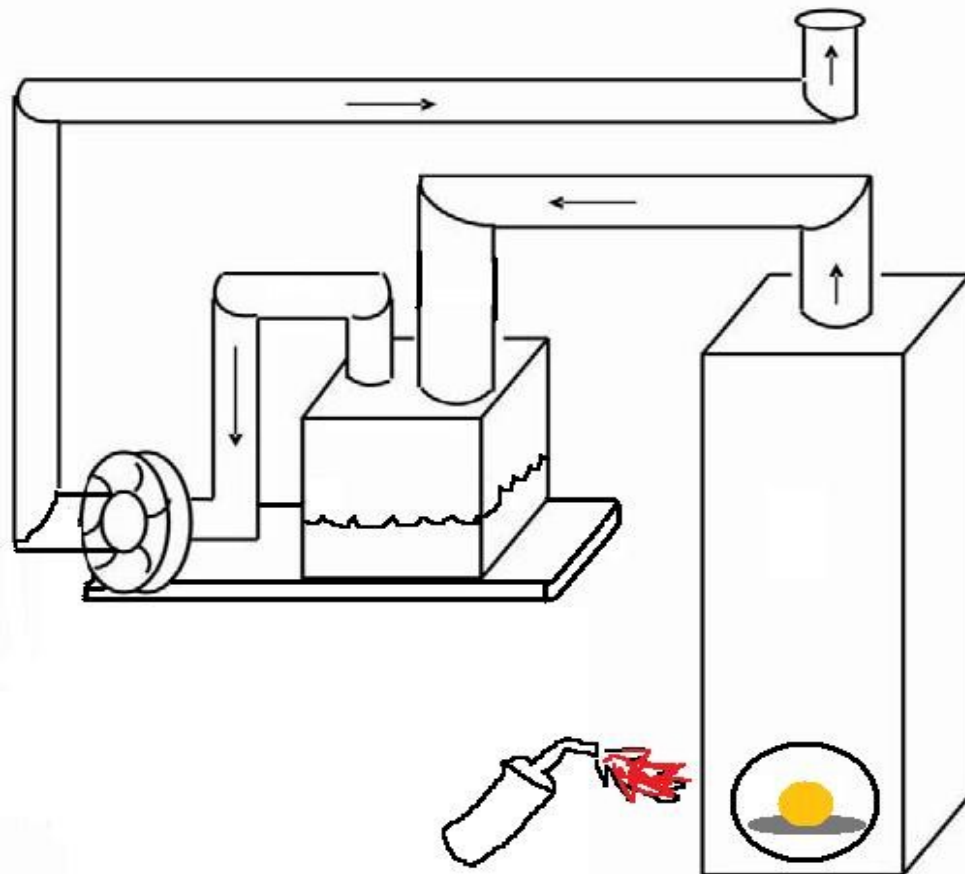

Mercury-Gold
Amalgam
(approx Au: Hg =
1: 1.4)



FUME HOOD

The Water Trap Condenser

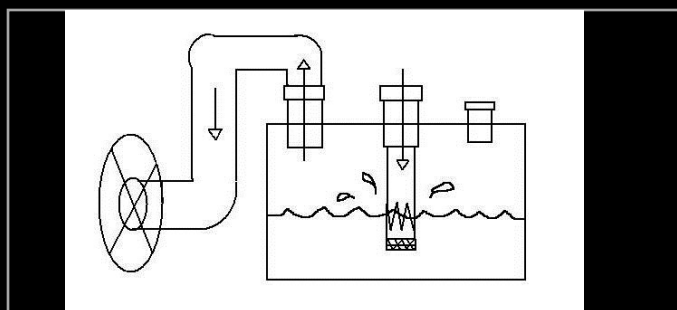
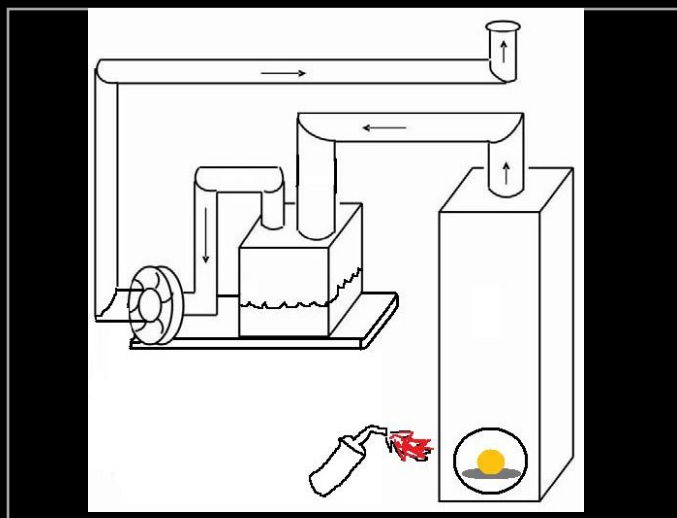

The design arose from the UNIDO Global Mercury Project, implemented in Kalimantan with the help of Yayasan Tambuhak Sinta (YTS), and direct involvement of local operators (Courtesy of Artisanal Gold Council)

FUME HOOD

THE TUPPERWARE FUMEHOOD *operating in "air sucking mode" - detail*

APPROXIMATE
DIMENSIONS SHOWN

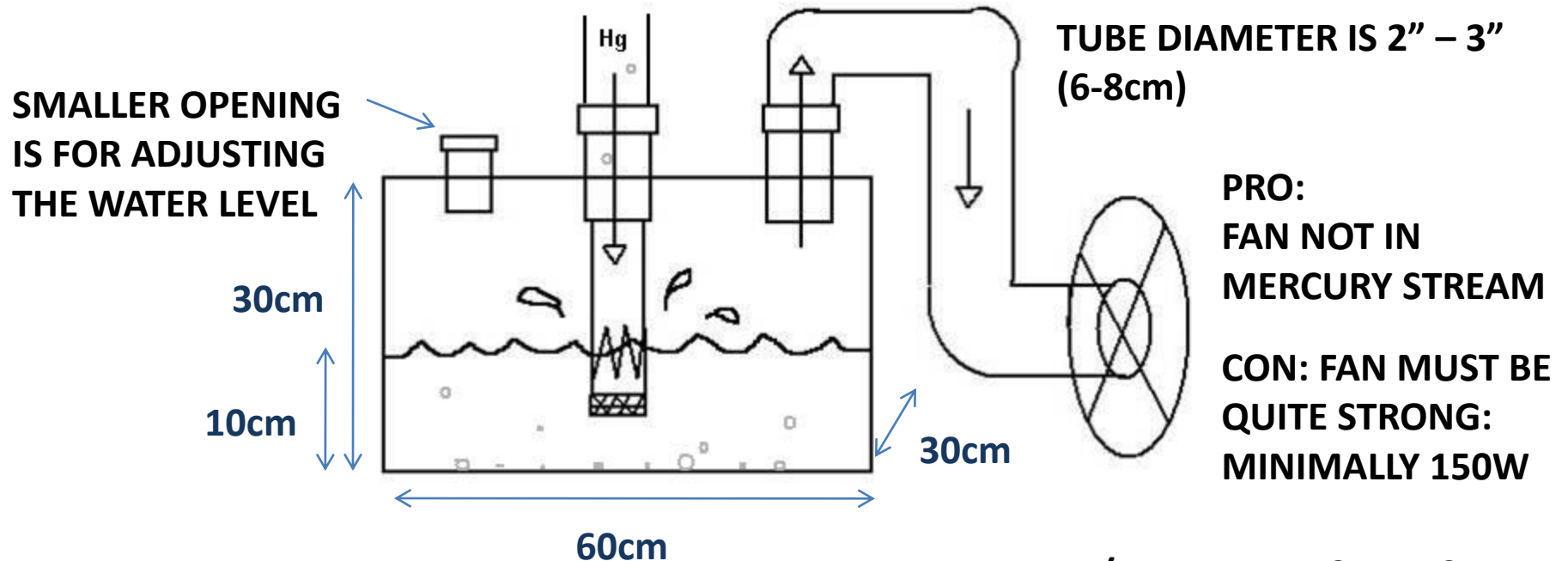

SMALLER OPENING
IS FOR ADJUSTING
THE WATER LEVEL

30cm

10cm

60cm

30cm

TUBE DIAMETER IS 2" - 3"
(6-8cm)

PRO:
FAN NOT IN
MERCURY STREAM

CON: FAN MUST BE
QUITE STRONG:
MINIMALLY 150W

CLEAR PLASTIC TUPPERWARE IS USED FOR BOX; LID MUST BE WELL SEALED. WIRE MESH IS USED AROUND TEETH (MESH SHOWN BELOW TEETH IN PICTURE) TO INCREASE BUBBLING.

TEETH AT WATER/AIR INTERFACE MUST ALLOW SOME AIR THROUGH . FUMEHOODS IN KALIMANTAN ARE RUNNING SUCCESSFULLY IN THIS MODE; FANS ARE 150W (1Amp) or 260W (1.6Amp). URLs for ELECTRIC BLOWER FAN DISTRIBUTORS ON SLIDE #5.

FUME HOOD

Empirical 'Hg vapor phase in air' saturation equilibrium data

Recall $1\text{mg} = 1,000,000\text{ng} = 0.001\text{grams}$.

This relationship implies that in a gold shop $6\text{m} \times 8\text{m} \times 3\text{m}$ (150m^3) at 30C , 3.9 grams of diffuse elemental mercury (vapor) is present if equilibrium is reached with available mercury. At 40C , 8.6 grams of mercury may be present.

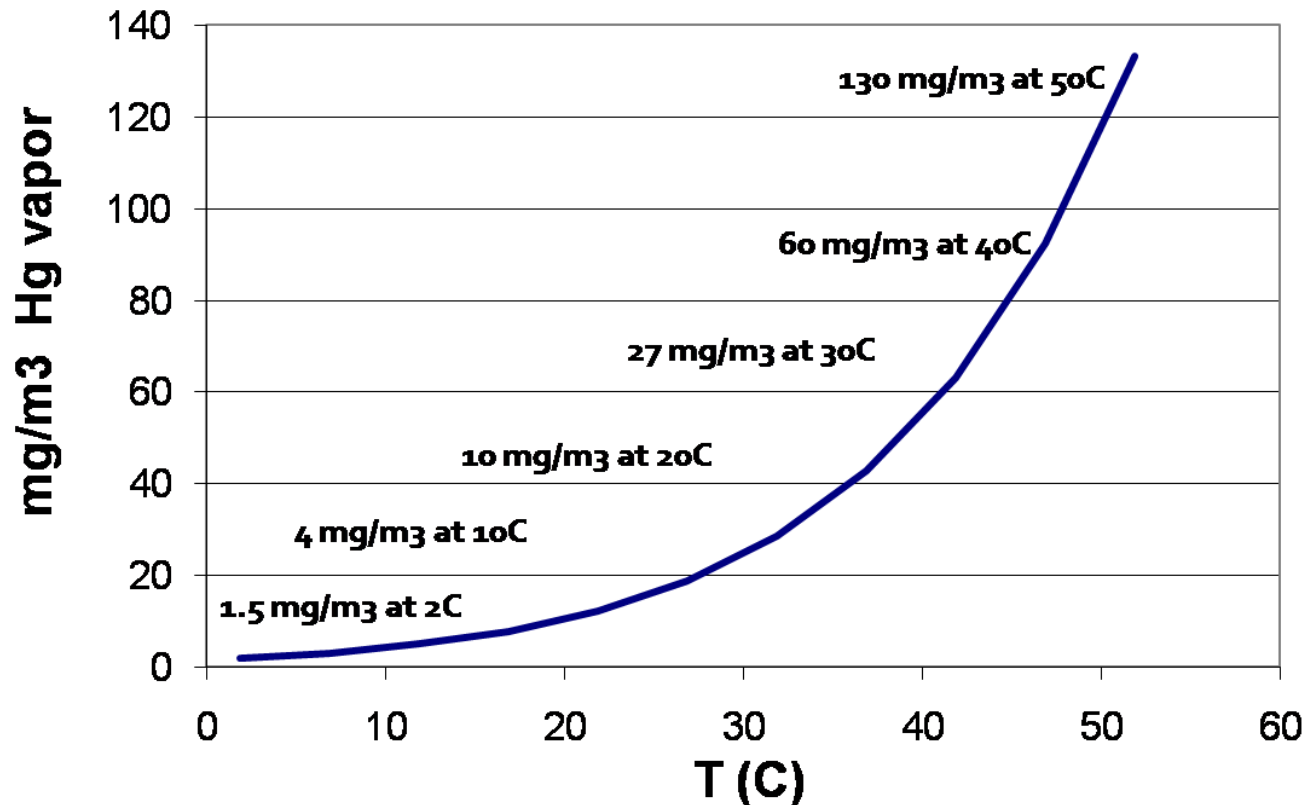

Testing the Water-Trap Condenser





OLD ORIGINAL
24/7/6
MONEY FOR NOTHING
FREE DELIVERY
FREE RETURN
7/7/6
THIS SIDE DOWN
EST. 1988
MONTREAL
MONTREAL
MONTREAL
MONTREAL

FUME HOOD

- Capable of capturing at least 62% of mercury emitted from burning amalgam (gold shop trials suggest more like 75% capture)
- A busy gold shop can recover up to 1kg of mercury per month
- Potential to prevent the release of at least 5 tons of mercury to the atmosphere on an annual basis
- More attention is needed to spread this and other mercury recovery technologies to ASGM



Accomplishment

- Interaction and consultations with Ministry of Energy and Minerals:
 - Introduced the project to ASGM Commissioner and ministry staff;
 - Received permit to involve Ministry supporting staff at Lake Victoria Zone and residents mines offices;
 - Zone and residents mines offices supported the project and appointed staff to accompany the project team

Accomplishment.....

- Interaction and relationship building with gold shop owners and small scale miners in Geita - Mwanza Region, and Ushirombo - Shinyanga Region:
 - Introduced the project idea to zone and resident mines office staff as well as gold shop owners and small scale miners;
 - Shared experiences on ASGM on opportunities and hindrances as well as modifications of the designs of the hoods to suit local conditions and affordability to many;
 - Analysed of mercury losses in amalgamation process activities in Geita and Ushirombo;

Accomplishment.....

- Installed fume hood condensers in Geita - Mwanza Region, and Ushirombo - Shinyanga Region:
 - Geita: Installed 2 fume hoods in two gold shops and Installed 2 fume hoods in two mining licensed sites
 - Ushirombo: Installed 2 fume hoods in one miners association owned mining site
- Planned to start in June - monitoring the deployment status of the technologies and technology design enhancement to suit local conditions and affordability to many





PRELIMINARY RESULTS

- **Mercury losses on amalgamation process**
 - It was observed that to every 4 gm of gold obtained there is a loss of mercury of about 0.75 to 1.5gm of mercury lost in the process of amalgamation.
 - Mercury losses in amalgamation process are attributed to:
 1. Mercury sticking on coarse particles of sand that contain AU (embedded on sand that contain gold);
 2. mercury dropping during panning processes and contained on the amalgamation ponds; and
- **Mercury capturing by using fume hood water condenser**



Transitioning Miners Away From Mercury Use

INTRODUCTION

- AGENDA implemented a project “Training of Trainers on Alternatives of Mercury and Best Available Techniques (BATs) and Best Environmental Practices (BEPs) in Artisanal and Small Scale Mining in Tanzania”
- Based on awareness raising on alternative technologies on recovering gold in central and lake zone by using Borax (Sodium Tetraborate)
- Similar project had been implemented in southern part of Tanzania by the Ministry of Energy and Minerals in collaboration with Department of Geography and Geology University of Copenhagen.

Introduction.....

The project is the outcome of:

- Study on Impact of Mercury Use by Artisanal Gold Miners in Tanzania, 2007; and
- National Mercury Forum, 2008 – organized a forum for different stakeholders in Tanzania;



Key Study Findings

- Borax seemed more expensive to use by local miners (Cost effectiveness i.e. selectivity, mass and heating requirement comparing to mercury);
- Mixture heating needs to be in well ventilated area



2010/07/21



Key Study Findings.....

- Retorts not used by miners as they require more heat (economically viable for large amount of amalgam)
- Cultural and belief reasons (visibility of transformations)

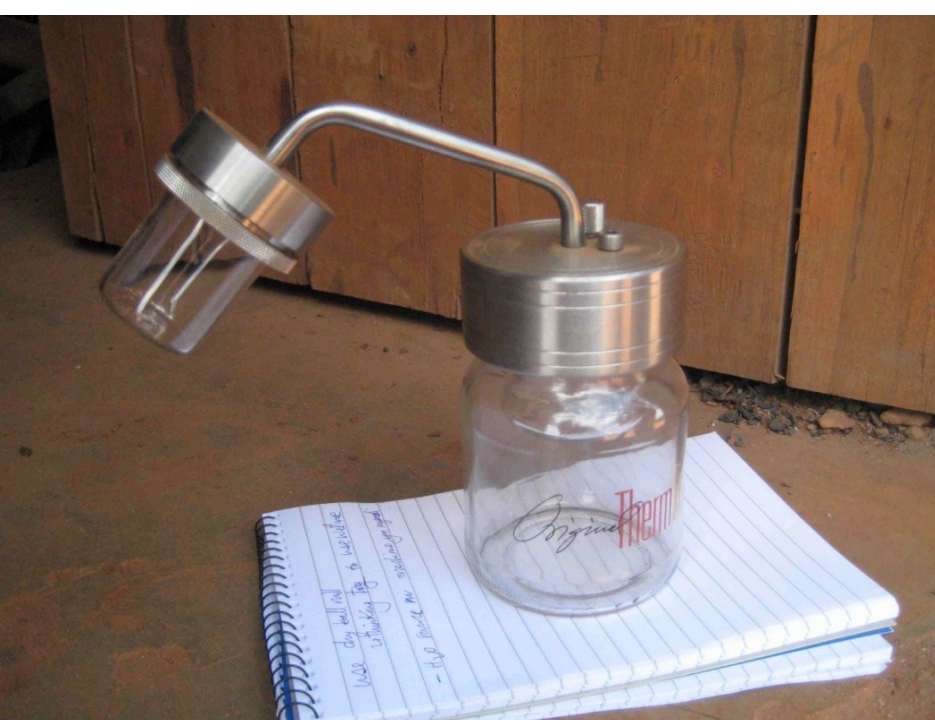

RECOMMENDATIONS FROM THE STUDY

- Alternative technologies should be thoroughly researched so that they will not turn out to be hazardous
- Explore locally available solution like the used of local equipments such as “Mkuba” for heating which is efficient and affordable as well as it can achieve to heat the materials to high temperature with locally available resources i.e charcoal;



HOW TO REDUCE MERCURY EXPOSURES AND TURNING AWAY FROM MERCURY USE

- More awareness raising on alternatives is needed to miners
- Facilitate and support (Technical and Financial) miners to form groups that can employ medium scale technologies (e.g. Cyanide)
- Reduce illegal mining by re-licensing to ASGM those large scale mining licences that are not developed for more than 20 years (e.g. STAMICO licensed areas such as Tembo Mine-Geita);



**Thanks for your
attention**

