



Liquefied Petroleum Gas (LPG)

Demand, Supply and Future Perspectives
for Sudan

Synthesis report of a workshop held
in Khartoum, 12-13 December 2010





The workshop was funded by UKaid from the Department for International Development

Cover image: © UNAMID / Albert Gonzalez Farran

This report is available online at: www.unep.org/sudan

Disclaimer

The material in this report does not necessarily represent the views of any of the organisations involved in the preparation and hosting of the workshop. It must be noted that some time has passed between the workshop and the dissemination of this report, during which some important changes have taken place, not least of which is the independence of South Sudan, a fact which greatly affects the national energy context. Critically, following the independence, the rate of deforestation in the Republic of Sudan has risen from 0.7% per year to 2.2% per year, making many of the discussions within this document all the more relevant. Whilst not directly affecting the production of LPG, which is largely derived from oil supplies north of the border with South Sudan, the wider context of the economics of the energy sector, and the economy as a whole, have changed. These changes are not reflected in this document. This being said, it is strongly asserted that this document still represents a useful contribution to the energy sector, particularly given its contribution to charting the breadth of perspectives on LPG in the Republic of Sudan.

Liquefied Petroleum Gas (LPG)

Demand, Supply and Future Perspectives for Sudan

Synthesis report of a workshop held in Khartoum,
12-13 December 2010

A joint publication by:

Ministry of Environment, Forestry and Physical Development – Sudan, Ministry of Petroleum – Sudan,
United Kingdom Department for International Development, United Nations Development Programme
and United Nations Environment Programme

Table of contents

Acronyms and abbreviations	4
Preface	5
Vision statement for LPG in Sudan	6
Workshop Programme	9
LPG Production, Consumption and Future Perspectives – Synthesis	11
Rationale	11
Sudan’s Energy Balance	13
LPG Trends	14
LPG Production: Eng. Mutamen (Khartoum Refinery Company)	21
LPG Supply in Sudan – Summary: Ian Thomson (Adam Smith International).	28
LPG supply	28
Significance of the Khartoum Refinery	29
Potential from Sudanese gas	29
LPG from Sudanese refineries	30
LPG supply and demand balance	31
LPG distribution	32
Potential for scale-up of LPG	34
Policy issues	34
LPG Demand in Sudan – Summary: Ahmed Hood (UNEP)	36
Recent history	36
Previous energy policies	37
Barriers	38
Recommendations	38
LPG Use in Khartoum: Margie Buchanan-Smith (UNEP)	40
LPG Supply	40
LPG Demand	41
LPG Governance	41
Conclusions	42
Microfinance for LPG – Demand Increase: Maja Bott (UNDP)	43
Forecast for LPG in Sudan (2000-20): Mohamed Salih Farah (Ministry of Petroleum)	49
Introduction	49
Energy Consumption Patterns and Trends	51
Energy Demand Forecast	52
Analysis and Comparison of Sectoral Final Energy Demand	54
Conclusions and Recommendations	57
Subsidy on LPG Production: Isam Eldeen Ahmed Kambal; Musa Hamid Mohamed (Ministry of Petroleum)	58
Introduction	58
Deficit in the nationally produced LPG	58
Deficit in the imported LPG	58
Conclusion	59
Increasing pressure on Forest Products – Gap Between Demand and Supply: Abdalla Gaafar Mohammed; Bulgies M. ElHassan Osman; Esmat Hassan Abdalla (Forests National Corporation)	60
The process of woodfuel substitution for LPG in the Sahel – a study of nine countries: Paul Kerkhof (UNEP)	62
Introduction	62
Senegal and Cape Verde: the early innovators	63
The case of Tchad, Niger, Burkina Faso and Mali	65
The case of Guinea Bissau and Gambia	66
Cross-cutting issues	66
Review of Previous LPG Disseminations Initiatives – The Gabat Gas Project Osama Tagelsir Gasim Elsaid (Forests National Corporation)	68
The Gabat Gas Project	68

Acronyms and abbreviations

Bpd	Barrels per Day
CDM	Clean Development Mechanism
CSB	Cement Stabilized Blocks
DFID	United Kingdom Department for International Development
FAO	Food and Agricultural Organisation
FNC	Forests National Corporation
GNESD	Global Network on Energy for Sustainable Development
GoNU	Government of National Unity
LPG	Liquefied Petroleum Gas
MEM	Ministry of Energy and Mining
MEFPD	Ministry of Environment, Forestry and Physical Development, Sudan
MtOE	Million Tonnes of Oil Equivalent
MoP	Ministry of Petroleum
NEC	National Electricity Corporation
SPC	Sudan Petroleum Corporation
SSB	Soil Stabilized Blocks
UNDP	United Nations Development Programme
UNEP	United Nations Environment Programme
UN-REDD	United Nations Collaborative initiative on Reducing Emissions from Deforestation and forest Degradation
WHO	World Health Organisation

Preface

This document summarises the proceedings of a workshop entitled *Liquefied Petroleum Gas (LPG): Demand, Supply and Future Perspectives for Sudan*, which was held in Khartoum on 12-13 December 2010.

The workshop was hosted by the Ministry of Petroleum under a joint initiative led by the Ministry of Environment, Forestry and Physical Development (MEFPD). The Under-Secretary of MEFPD chaired a steering group comprising MEFPD, the Ministry of Petroleum, the Forestry National Corporation, DFID, the United Nations Development Programme (UNDP), and the United Nations Environment Programme (UNEP).

The workshop brought together a diverse group of stakeholders to explore the use of LPG as an alternative source of energy to displace the reliance on wood fuel in Sudan.

It therefore reflects a number of different concerns relating to the use of LPG including:

- **Replacement of demand for energy from woodfuel** – to reduce the rate of deforestation in Sudan;
- **Poverty alleviation** – particularly with reference to how microfinance for LPG can enable poor communities to access fuel; and
- **Health** – to reduce the impacts on health from indoor air pollution.

This publication contains a compilation of the working papers presented during the workshop and is preceded by a joint statement that was drafted during the workshop.



Vision statement for LPG in Sudan

The following statement was drafted during the workshop – LPG Demand, Supply and Future Perspectives – which took place in Khartoum, from 12-13 December 2010.

Rationale

Sudan faces high rates of deforestation with Northern central states having lost 70% of their forest cover since independence. Woodfuel is now being brought in to these central areas over several hundred kilometers from areas such as Blue Nile and South Kordofan. This is exacerbating problems of deforestation and desertification across Northern Sudan.

In order to reduce this deforestation, LPG provides a clean and cost effective alternative for use, particularly in urban areas. In addition to these environmental advantages, scaling up LPG use has potential benefits with regard to health, poverty alleviation and the lives of women. These come from reduced indoor air pollution, and reduced time and money spent foraging or collecting woodfuel. The use of LPG also provides potential reduction of national carbon emissions due to the reduced loss of forestry.

Process

The workshop programme started with presentations on four major themes:

- LPG Production
- LPG Supply
- LPG Policy in Sudan
- Potential Woodfuel Displacement

Following this the workshop broke into four working groups to discuss the following themes:

- LPG – Context
- LPG – Projects
- LPG – Finance
- LPG – Supply

The outputs from the working groups on these themes were then reviewed during a gallery walk at the end of the first day, allowing for dialogue between the working groups. Records from the groups and the

comments made during the gallery walk provided the basis of a draft workshop summary document outlining a vision and practical next steps.

On the second day, a panel discussion in plenary allowed for more substantial dialogue between the different working groups, particularly a synthesis in the analysis between the LPG demand and supply sides with voices representing the environment, poverty alleviation, health and other concerns. Following this the working groups reconvened to review the draft workshop summary. Modifications have been made according to their feedback. The final version (edited for clarity, but not content) is presented below.

Vision

The following components of a vision for the way forward on LPG in Sudan were articulated. Sudan should:

- 1) Scale-up the use of LPG and other more sustainable energy sources;
- 2) Decrease demand for wood and woodfuels;
- 3) Promote energy efficiency;
- 4) Increase conservation efforts across the country;
- 5) Promote research, development and dissemination of alternative energy technologies;
- 6) Support low-income households to access alternatives to the use of woodfuels;
- 7) Launch awareness campaigns to raise awareness of the in this document.

Priorities for action

Policy

Undertake a comprehensive policy review in partnership amongst all LPG stakeholder agencies. This should lead to:

- Cross-sectoral policy alignment on energy, forestry, finance, transport, poverty reduction and safety (horizontal alignment). Highlight the

role of private sector and NGOs in addition to line ministries and agencies.

- Alignment of federal and state-level policy and regulations on LPG and other more sustainable energy sources (vertical alignment). Highlight the role of state level ministries and agencies in this process.
- Standardize data collection and analysis across the energy sector to promote improved energy planning.

LPG production

- Increase Sudan's refinery production capacity for LPG.

The Ministry of Petroleum announced during the workshop that it is planning to double the capacity of the Khartoum refinery by 2014, and the El Obeid refinery by 2013.

LPG pricing and subsidies

- Review subsidies and taxation so that benefits are better targeted for low-income households.
- Target strategies to help making refilling more competitive with woodfuels.
- Include consideration of transportation costs when setting pricing strategy to reduce variation in prices across the country.

Research findings from the World Bank, UNDP and lessons learned from other countries (Senegal, Brazil, India, etc.) on the pit falls of gas-related subsidies should be considered when deciding on new subsidy policies, for example for cylinders, appliances and direct subsidies for poor households.

Microfinance initiatives

- Develop financing packages that are designed for a group of households or a community, rather than just for individuals. A greater involvement of women's groups is has potential to enhance the impact of this initiative.
- Investigate and disseminate information on Clean Development Mechanism (CDM) and carbon credit funds could be used to support the scale up LPG use, given the overall benefits in reducing forest loss.

- Promote the participation of LPG suppliers in partnerships with microfinance specialist organizations, for scale up of LPG and other alternative energy sources.

This could be done by reactivating Ministry of Petroleum's risk share guarantee fund and broaden its use beyond solar energy. A special fund could be created to insure money lenders' losses incurred due to pay-back fall-out.

Public awareness

Launch national awareness programmes through media and schools to promote understanding of:

- Health risks of indoor air pollution from use of woodfuel;
- Environmental harm caused by deforestation;
- Availability of LPG and other environmental alternatives;
- Safety of LPG appliances.

Fuel-efficient stoves

- Promote major scale up of the use of fuel-efficient stoves. This should form part of a wider programme on fuel efficiency.

Forest management

- Promote security of Sudan's forests as they are a valuable national asset.
- Conduct feasibility studies on co-financing through REDD, CDM and / or carbon trading.

An emphasis is needed on supporting forest-based livelihoods such as woodlots, honey, gum Arabic, wild fruits, etc. in order to promote community management of forested areas. Tree-planting is a useful contributing activity provided it is accompanied by improved forestry management.

Poverty alleviation

- Support income-generation of very poor households to enable them to benefit from energy initiatives.

These activities should be done in a manner that is complementary to pricing reforms and provision of microfinance as discussed above.

Distribution

- Review the experience of use of small cylinders targeted to enable poor households unable to afford refilling larger cylinders. Identify lessons from earlier initiatives and provide support accordingly.
- Establish minimum technical standards for appliances to prevent additional costs for consumers when switching from one gas company to the other.
- Promote local manufacturing of cylinders and appliances.

Transportation

- Consider subsidy of transportation of LPG (rather than only the LPG product itself), so that nationwide distribution is secured at regional price variability can be reduced.
- Assess potential for investments in the railway network and depots to contribute to LPG distribution.

Safety

- Promote good practice through development, dissemination and training on safety standards

Alternative technologies

- Assess and scale up use of alternative energies subject to assessment. Address energy contexts of households and small and medium enterprises. Include:
 - Solar;
 - Biogas;
 - Biofuels.
- Promote integrated cooking technologies.
- Conduct feasibility studies and pilot energy technologies for LPG-fired brick, lime and gypsum kilns as well as bakeries.
- Develop a strategy for natural gas in addition to LPG.
- Assess the feasibility and potential for localized distribution networks for natural gas and LPG.



Workshop programme

Day One: Sunday 12 December 2010

8.00 – 8.30: Registration and Coffee Holy Quran	Ingaz Hall
8.45 – 9.30: Opening Speeches of Excellencies Chairperson: Ahmed Hood (UNEP) Brendan Bromwich (UNEP) Hamad Alneel Abdulgadir – Deputy Under Secretary (Ministry of Petroleum) H.E. Fadwa Ashai – State Minister (Ministry of Environment, Forestry and Physical Development)	Ingaz Hall
9.45 – 11.00: Plenary Sessions (Main Presentations) Chairperson: Dr. Babikir Abdella Ibrahim LPG Production (Eng. Mutamen, KRC/MoP) LPG Supply (Ian Thomson, DFID) LPG Policy in Sudan (Ahmed Hood, UNEP) Wooduel Displacement (Esmat Hassan, FNC)	Ingaz Hall
11.00 – 11:45: Breakfast & Coffee	Ingaz Hall
11:45 – 12:45: Working Group Sessions <i>Presentations & Discussion: Presenters first explain their paper to each sub-group</i>	Oil House
Group A: LPG – Context Moderator: Brendan Bromwich (UNEP) LPG Demand in Khartoum (Ahmed Hood, UNEP)	
Group B: LPG – Projects Moderators: Nagla Magoub (FNC), Corinna Bothe (UNEP) LPG Past Experiences: GabatGas Project (Osama Tagelsir, FNC) Fuel-efficient Stoves in El Fasher (Eng. Shebeika, Practical Action)	
Group C: LPG – Finance Moderator: John Wearing (DFID) LPG Subsidies (Isam Eldeen Ahmed, MoP) LPG Microfinance (Maja Bott, UNDP)	
Group D: LPG – Supply Moderator: Ian Thomson (DFID) No presentations – Review Plenary Presentations on LPG Supply (KRC, DFID)	
12:45 – 13:45: Lunch, Praying	
13:45 – 14:45: Gallery Walk – Group Findings	Oil House
14:45 – 15:15: Closing Session	Ingaz Hall

Day Two: Monday 13 December 2010

8:30 – 8:45 Registration and Coffee	Oil House
9:00 – 9:20: LPG Experiences across the Sahel (UNEP) Fabian Kreuzer (UNEP)	Oil House
9:20 – 11:00: Synthesis & Panel Discussion Chairperson: Brendan Bromwich (UNEP)	Oil House
11:00 – 11:45: Breakfast & Coffee	
11:45 – 12:45: Working Groups: Draft Workshop Summary Group A: Context Group B: Projects Group C: Finance Group D: Supply	Oil House
12:45 – 13:45: Lunch, Praying	
13:45 – 14:45: Plenary Review of Workshop Summary Working Groups A, B, C, D present their suggestions	Oil House
15:00 – 15.30: Closing Session Chairperson: Robin Bovey (UNEP)	Oil House
Holy Quran	

LPG Production, Consumption and Future Perspectives – Synthesis: Ulrich Mans (UNEP Consultant)

Rationale

This document reflects the work of key stakeholders who were present during the workshop “Sudan – LPG Production, Consumption and Future Perspectives”. This event was hosted by the Ministry of Petroleum in Khartoum, on 12-13 December 2010, in cooperation with the Ministry of Environment, Forestry and Physical Development, DFID, the United Nations Development Programme and the United Nations Environment Programme.

The objective of the workshop was to identify how best to scale-up the use of Liquefied Petroleum Gas (LPG) as a cleaner source of energy. This is key to securing the country’s future energy needs. Today’s unsustainable use of natural resources for energy is a major concern and needs to be addressed. It has led to great environmental damage, is a barrier to poverty alleviation and presents a significant challenge to public health.

Because of Sudan’s rapid population growth and economic development of the last decades, the impact on the **environment** is much greater today than it was in the past. Natural resources are becoming increasingly scarce at an unprecedented rate, and Sudan faces alarming rates of deforestation. In many regions, current demand for forest resources outstrips the available woodlands, and reports indicate that 70% of north-central Sudan’s forest cover was lost since 1956. The most important driver of deforestation, despite a recent decline, is household energy consumption followed by wood-based construction techniques, agricultural schemes and overgrazing.

In 2009, the demand for woodfuel and charcoal still represented 63% of Sudan’s energy balance. Studies from 2010 also indicate that the related woodfuel and charcoal trade contribute to the conflict dynamic across the Kordofan region. Woodfuel and charcoal are traded across long distances, mainly from the South and South-East states to the centre of North Sudan as a woodfuel mapping shows. Furthermore, following the secession of South Sudan the rate of deforestation in the Republic of Sudan has risen from 0.7% per year to 2.2% per year. This represents an alarming annual rate of deforestation which much be addressed.

The massive use of woodfuel has greatly affected the livelihoods of the poorest in the country. Because many rural households have no means to switch to cheaper energy sources, they have to rely on wood-fuel for daily cooking needs in the absence of finance institution to enable them to change. This way, the widely available woodfuel acts as a barrier for **poverty alleviation**. Poor households have no alternative to time consuming open-fire cooking. The major reason for rural households not to switch to LPG is the involved costs. Woodfuel is available in small quantities and affordable on a day-to-day basis, cheaper and cleaner energy sources with high upfront costs are not. This gap between woodfuel and LPG is particularly high in remote areas, where LPG prices are much higher than in central Sudan: a 12.5kg cylinder in Khartoum costs 12-15 SGD, and 31-42 SDG in Nyala, El Fasher and El Geneina.

Figure 1. East Africa – Woodfuel Integrated Supply/Demand Overview Mapping (WISDOM) Methodology

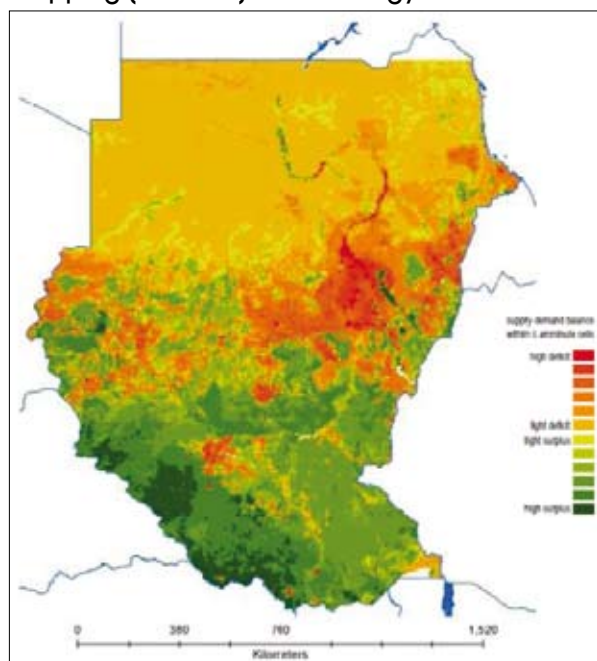

Spatial woodfuel production and consumption analysis of selected African countries. Prepared by R. Drigo for the FAO Forestry Department – Wood Energy www.fao.org/docrep/009/j8227e/j8227e00.HTM

Figure 2. Prices in Sudan for refilling a 12.5kg LPG cylinder

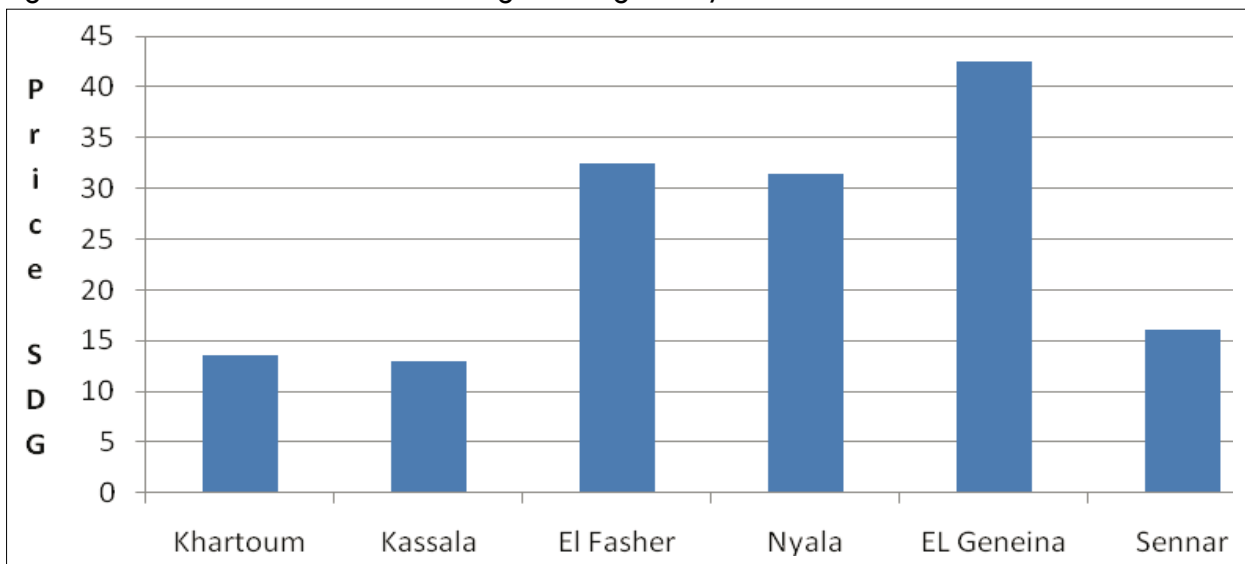

Source: Practical Action (2008), Proposal for dissemination of LPG use in El Fasher

Figure 3. Pollution and emission levels of household energy sources

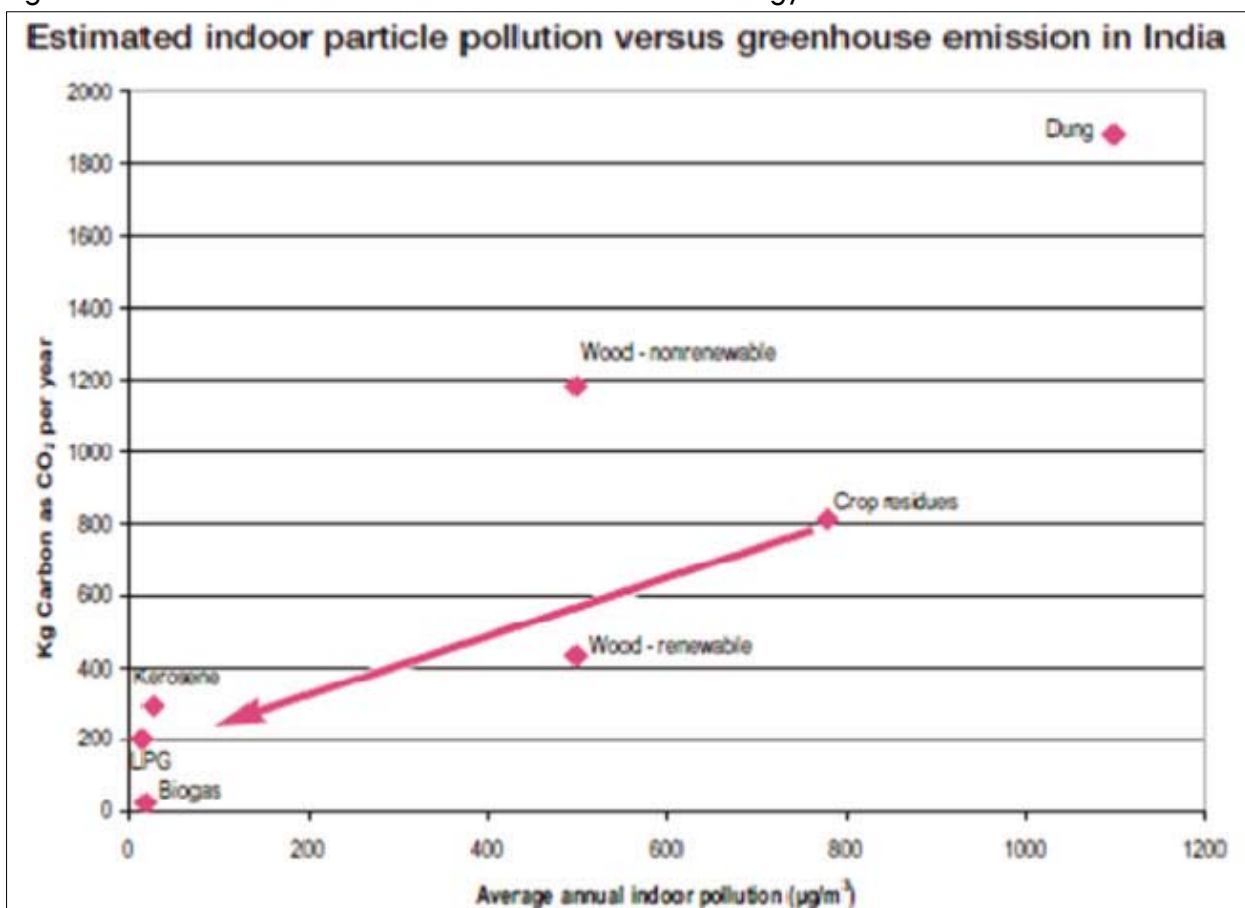

Source: Kirk R. Smith et al. (2005), Household Fuels and Ill-Health in Developing Countries: What improvements can be brought by LP Gas, World LP Gas Association

Figure 4. Sudan's energy balance 2009

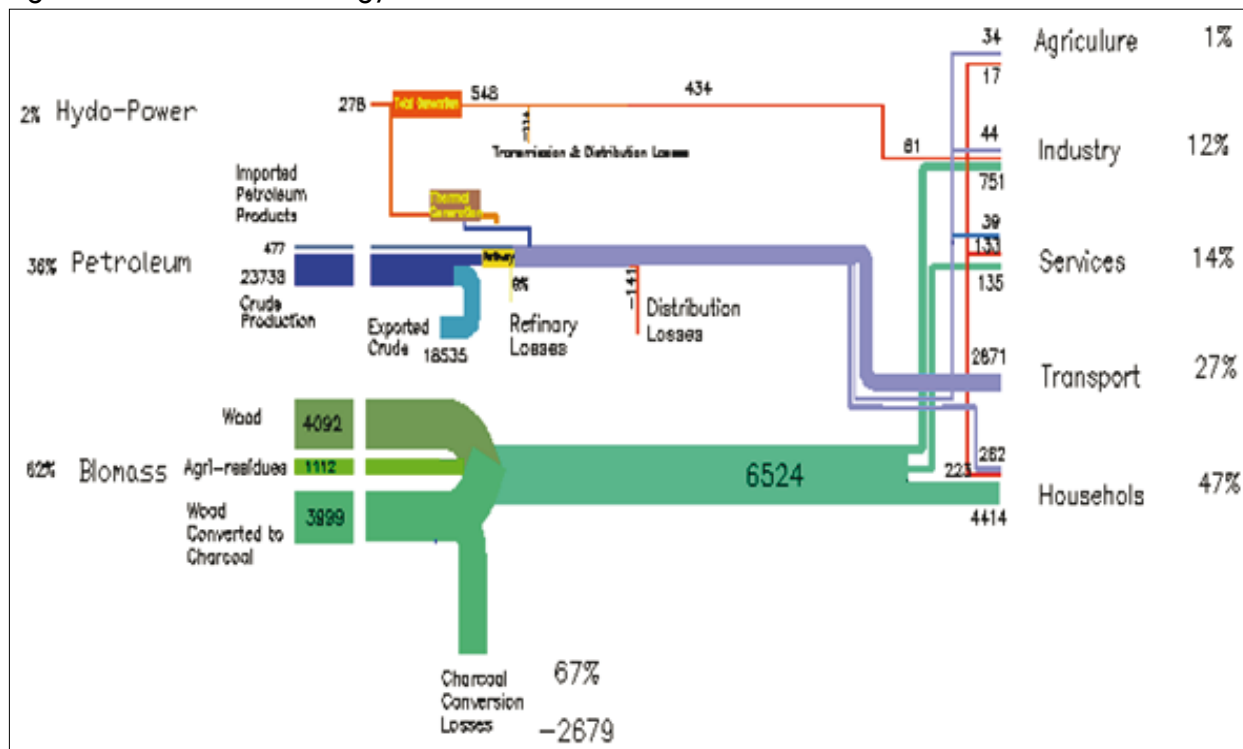

Source: Ministry of Energy and Mining (2009), Sudan Energy Handbook

Many people suffer from the direct consequences of wood-fuel based cooking, making LPG scale-up an important **public health** issue. WHO warns that acute lower respiratory infections caused by in-door air pollution are wide-spread and responsible for nearly half of the deaths among children under five years.¹ Tests in Kassala show that carbon monoxide concentrations are 20 times higher than international standards.² Public health can be significantly improved if households switch from biomass fuels to LPG.

The most appropriate way to match the current levels of energy demand with available energy sources lies in LPG usage. If LPG was available to those consumers that represent 63% of the country's energy needs, it could lessen the negative effects on environment, poverty alleviation and public health. This is an opportunity for the government of Sudan and the international com-

munity should support national efforts to reach this goal.

Sudan's Energy Balance

The challenge to Sudanese energy management lies in balancing the interests of economic growth, poverty alleviation and environmental protection. Energy demand has increased significantly starting with oil production in 1999, and with the resulting economic growth. Since then, the share of biomass in the overall energy balance has gradually shifted from an estimated 82% in 1999 to 65% in 2007 and 63% in 2009. This splits into wood fuel, charcoal (44% each) and agricultural residues (12%). The share of petroleum products has increased dramatically since 1999, to 36% in 2009, mainly due to transportation and power generation. Hydropower provides another 2% to the national energy supply. Transmission losses are very high, given Sudan's dependence on biomass: 67% energy losses occur when turning wood into charcoal. In 2008, this amounted to an estimated one third of all energy supply lost: 14.9 million tonnes oil equivalent (mTOE) total energy produced compared to 9.8 mTOE available to consumers. Minor transmission losses occur through refining and the distribution of petroleum and hydropower.

1) World Health Organization (2004) *Indoor Air Pollution, Household Energy and the Millennium Development Goals – Indoor Air Thematic Briefing*, <http://www.who.int/indoorair/info/iabriefing1rev.pdf>

2) Practical Action (2006), *Smoke Project Progress Reports and publications* http://www.dfid.gov.uk/R4D/PDF/Outputs/EngKar/R8345_Vol2_Annex04.pdf

The overall energy demand is still relatively low for international standards. Sudan ranks among the least-polluting economies worldwide in terms of emissions, and as a result of the post-1999 period of growth, Sudan only recently experienced the negative effects of industrialisation. The country has a CO₂ emission rate of 0.3 million tonnes (Mt) per capita, which is 44 times lower than high-income OECD countries and 15 times lower than the average for Arab states. Instead, environmental degradation is manifested through deforestation, desertification and pollution.

On the demand side, consumers of the available energy divide into five main groups: households (47%), transport (27%), services (14%), industry (11%) and agriculture (1%). The majority of biomass goes to households, and to a much lesser extent to industry and services. Out of the petroleum products that are not exported (22%) the greatest share goes to the transport sector. The small amounts of hydropower distribute evenly across all five groups (see figure 4).

The challenge to Sudan's energy balance is three-fold:

- The high level of wood-fuel in the overall equation is unsustainable and its share needs to be offset by alternative energy sources. Hydropower alone is insufficient and – despite current plans to expand the national grid to provide up to 90% of the country with electricity - this will not offset the increasing energy demand entirely.
- Bulk solutions are not likely to have much effect. The major gains lie in reducing the household share of current energy needs. It is the single most important issue that needs to be addressed, and the most difficult target group to reach.
- The increasing demand for LPG has to be matched with sufficient supply. Biomass has already been over-used as a source of energy. National petroleum production might soon decrease, and without major new findings many expect shortages of petroleum. Imports are an expensive option and would require significant adjustments in terms of oil-related subsidies.

Urbanisation, population growth and higher living standards drive the rise of the country's energy demand. If nothing is done in the very short term, energy needs across Sudan will culminate in major energy shortages, or an increasingly serious environmental crisis, which would affect livelihoods across all regions of the country.

LPG Trends

This section is based on the content of studies or presentations by key stakeholders in energy programming in Sudan that were presented during the LPG workshop "Liquefied Petroleum Gas (LPG): Demand, Supply and Future Perspectives for Sudan" on 12-13 December 2010.

1) Policy

Key stakeholders in North Sudan's energy sector include the Ministries for Petroleum, Finance, Ministry of Environment, Forestry and Physical Planning, Civil Defence, Mining and Electricity respectively. The Ministry of Petroleum is in the lead to formulate and implement energy policies, in close consultation with the other ministries. The Ministry of Finance is involved due to the subsidy schemes for petroleum products and electricity introduced in the early 2000s, and Civil Defence plays a role as it is responsible for the safety (standards) of petroleum production, transport and distribution. In addition to these ministries, there are three public corporations that are at the centre of Sudan's energy sector. First, the National Electricity Corporation (NEC) is responsible for generation, transmission and distribution of electricity. Second, the Forests National Corporation (FNC) is in charge of the wood resources' protection and management and runs state offices with the task of supervising the supply and demand of firewood and charcoal. Third, the Sudan Petroleum Corporation (SPC) runs all aspects of the petroleum industry, from first exploration to final end use. Closely related to the SPC, the Nile Petroleum Company controls 52% of the petroleum products distribution, and is also the main handling agent for LPG.

The issue of LPG should be seen in the context of national energy management. Production was scaled up in conjunction with petroleum production in the Khartoum refinery, and a large-scale subsidy scheme ensured that traders could purchase LPG

Figure 5. LPG Demand by Sector (kTOE)

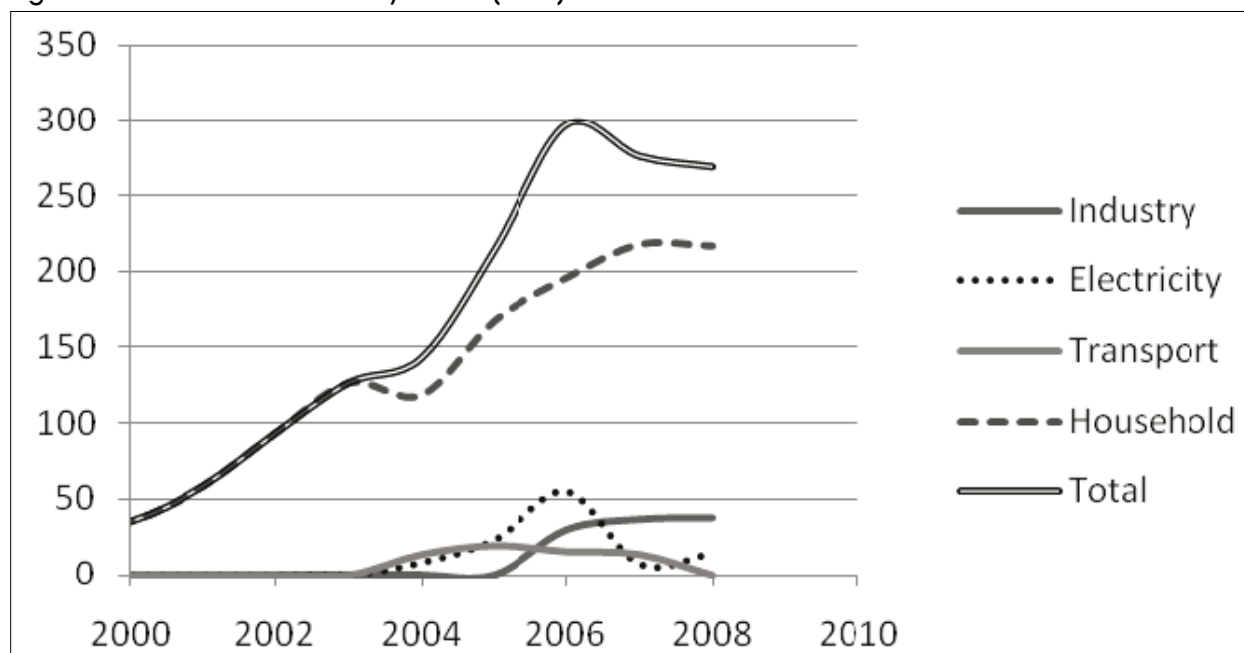

Source: Graph produced by Dr. Ahmed Hood (UNEP Consultant) based on: Ministry of Energy and Mining / Sudan Petroleum Corporation (Statistical Book, no date), Available online at: <http://www.spc.sd/pdf/Oil%20Statistics-Version1.pdf>

for 50% of the international market price. Existing subsidies on fuel further encourage the distribution of LPG by trucks across the country. In addition, many taxes had been introduced to make wood trading less competitive, and LPG-related appliances were exempted from custom duties. As a result, LPG consumption witnessed a massive increase over the last decade, particular in urban centres in Khartoum, Gezira and Central Sudan. Growth has now stabilized at around 5% per year. A major change occurred in January 2011, when the Sudanese government decided to cut back on petroleum-related subsidies. This led to a price increase of approximately 30% on fuel. LPG subsidies are not affected, however as transportation costs increase, LPG prices are expected to rise relative to the distance from major supply centres.

In order to further increase the use of LPG, attention has focused on displacement of wood-fuel. Many do not see the immediate benefits from changing the energy source. LPG-related policies can facilitate consumers to overcome these concerns. This requires policies towards specific target groups and needs to be coordinated among the many different public entities that are responsible. Thus far, these efforts have a mixed track record, especially the policy coherence between the federal and state level. In order to achieve a higher

level of LPG penetration among the main biomass consumers, policies need to be coherent and have to be followed-through rigidly – from national to local levels.

2) Supply and distribution

Sudan's petroleum industry has an annual LPG output of approximately 350,000 tonnes. This comes exclusively from the Al Jalli refinery north of Khartoum. While the maximum capacity of the refinery stands somewhat higher at 420,000 tonnes, this would require very high levels of utilisation (100%). With current demand at around 310,000 tonnes per year, the limits of current production levels are already in plain view: with an assumed annual increase of 5%, demand will outstrip supply in 2013/14.

Other potential sources of LPG are unlikely to be available before this limit is reached. Potential gas reserves in the Red Sea and Sinnar State not been proven and depend on successful exploration and on the economic viability to transport it further inland to major consumption centres. Another option, which would catch gas that would otherwise be flared by oil companies, is even less attractive. This technique is relatively expensive, and would not contribute much given the scale of the supply

Figure 6. LPG production and demand 2000-2020

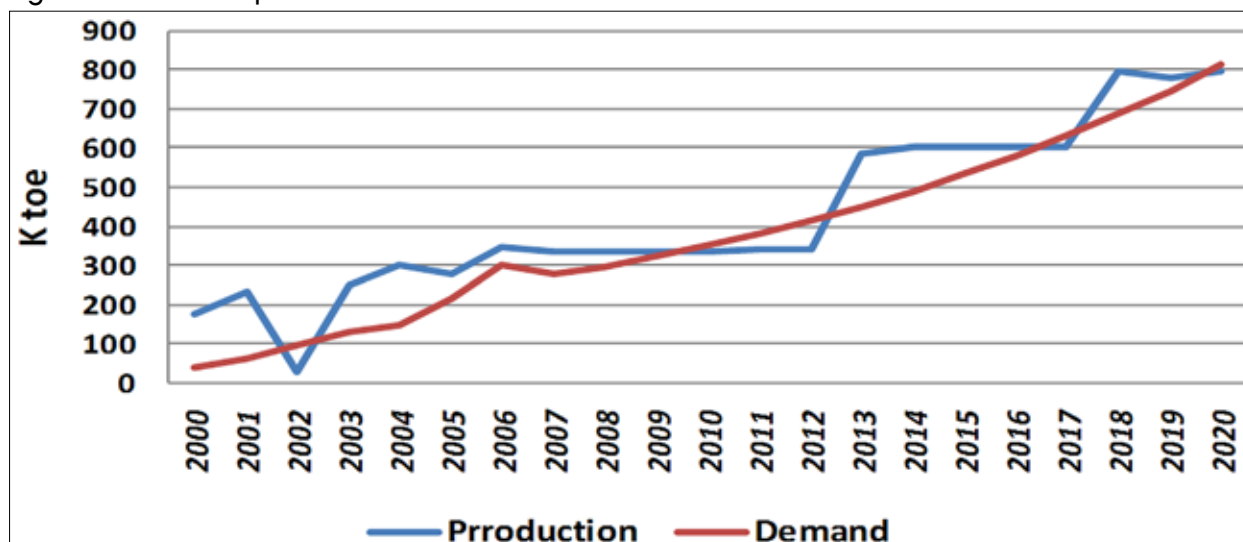

Source: Graph produced by Dr. Ahmed Hood (UNEP Consultant) based on: Ministry of Energy and Mining / Sudan Petroleum Corporation (Statistical Book, no date), Available online at: <http://www.spc.sd/pdf/Oil%20Statistics-Version1.pdf>

problem. Imports might be a last resort in order to increase supply. This remains a very costly choice however, given that imported LPG would have to be bought by international market prices. This, in turn, would be much higher than the subsidised LPG produced in Sudan. The only short-term alternative is to expand current refinery capacity, and to ensure that Sudan's oil reserves are being used to maximise LPG production in the coming years.

The Ministry of Petroleum announced plans to expand the Al Jaili refinery by 2014. If this is finalised on time and oil production continues accordingly, the level of LPG supply would be sufficient in order to follow-through with plans to scale-up LPG consumption across the country. An alternative is to cut back on all subsidies, and in turn import additional LPG for international market prices or under a favourable bilateral agreement with a LPG-supplying country.

In 2011, the LPG distribution network was underdeveloped. Whereas additional supplies are a prerequisite for LPG scale-up, the distribution facilities across the country are at least as important. However, most remote areas have not yet benefited from a stable supply. As a result, they have far lower levels of LPG consumption. This is mainly due to the limited appetite by major distributors to risk investing in additional, more remote LPG depots. There are seven companies involved in the LPG business, which collectively manage an estimated three million 12.5kg cylinders.

Khartoum is key to their business: two thirds of their sales go to households in the capital. The further away the location, the lower the business prospects. As a result, the largest facilities are currently located in Al Jaili, Al-Shajara, Port Sudan and Wad Medani. Regional depots exist in every Northern state. These numbers have thus far not provided a stable supply to remote locations, and supply problems have frequently surfaced even in Khartoum.

3) Household & health benefit

Energy use of households is the biggest challenge for LPG policy in Sudan, and would result in the greatest gains if a policy proved successful. An estimated 67% of the total woodfuel was being used in households in 2009, and 84% of the total charcoal consumption. This was reflected in the share of households in today's LPG business: bulk consumption for industrial use only accounted for 5% of the total LPG market, the remaining supply was sold to residential customers.

There are clear benefits to households when switching to LPG. One of the most significant gains for family life in rural areas comes from improved air quality in their homes. Biomass results for in-door air quality show that carbon-monoxide levels are 20 times higher than World Health Organisation (WHO) standards and in today's Sudan, half of the children who die under the age of five die from acute lower

Figure 7. Distribution of energy sources for Sudanese households in 2001

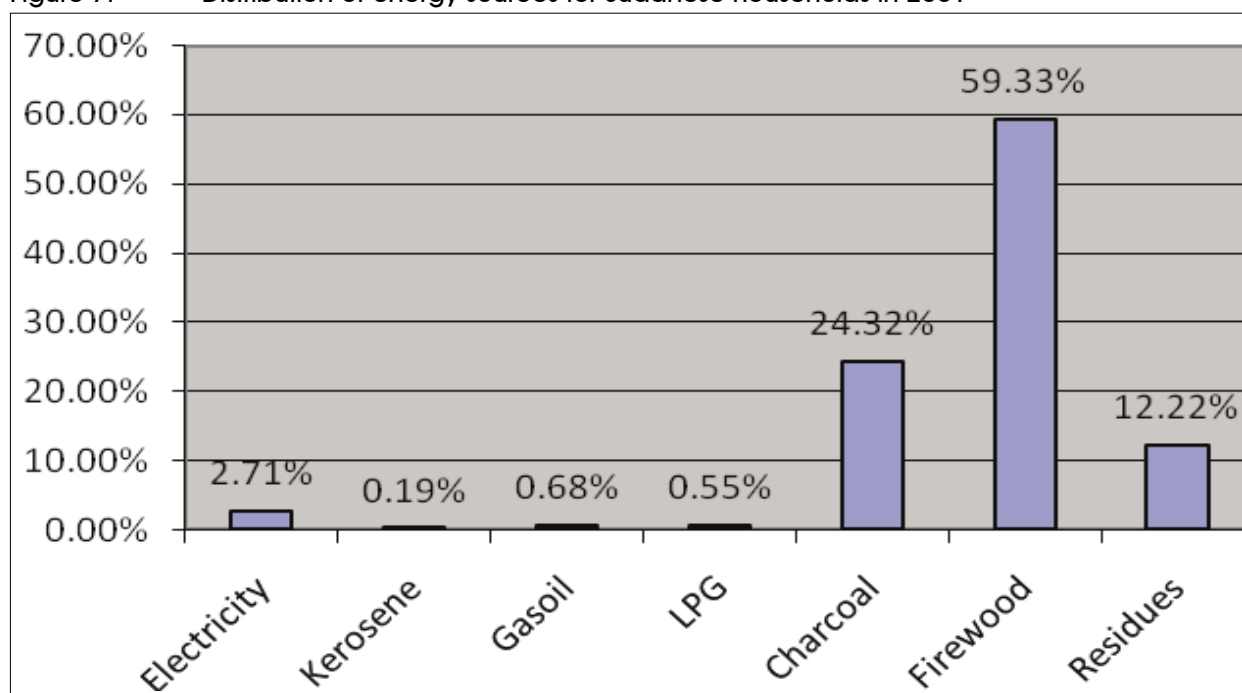

Source: Ministry of Energy and Mining (2001). Second National Energy Assessment. Khartoum, Sudan

respiratory infections. The positive effect on family economics is evident on the long-term, potentially freeing up funds for other expenses. Environmental benefits related to lower levels of deforestation, such as more arable and grazing land, speak for themselves but are less visible for the average person in the village.

Many barriers to LPG uptake remain, and prevent most households from embracing LPG as an alternative source of energy. These barriers include four major issues:

- The high up-front costs are prohibitive to many. The deposit for the cylinder and the payments for a refill are much higher than the required expenses for daily purchase of wood fuel. This is particularly important for rural families with little dispensable income. They prefer to buy wood fuel, as it is available in small day-to-day quantities. Microfinance programmes in El Fasher and Kassala have proved that with local commitment and managerial skills from people in the communities (particularly women organisations), it is possible to maintain high levels of payback, and to create a sustainable footing for LPG use.
- Woodfuel still offers a competitive price in comparison to LPG in much of the country.

Whereas the urban populations in Khartoum – where refilling a cylinder costs between 12 and 15 SDG – have found LPG to be much cheaper than woodfuel, refill prices in remote areas can be up to four times of what is paid in the capital. This is due to fees and taxes that are added in the course of LPG transport. In order for households in more remote areas to adopt LPG, refilling prices must be as competitive as they are in Khartoum.

- Providing regular supply is difficult. The LPG storage and distribution networks could be expanded so that they can cover the local demand until supplies with individual agents can be replenished.
- Many are still reluctant to accept LPG due to socio-cultural practices within the household sector. Many families are hesitant to change their lifestyles, particularly in the context of unpredictable prices and local supply. In addition, there is a lack of awareness around the benefits of LPG. Many do not know about the health risks and likely impacts of environmental degradation on their livelihoods caused by wood fuels, and are convinced that LPG is unsafe and more expensive than wood fuel.

Figure 8. Regional annual wood fuel usage by bakeries in selected years

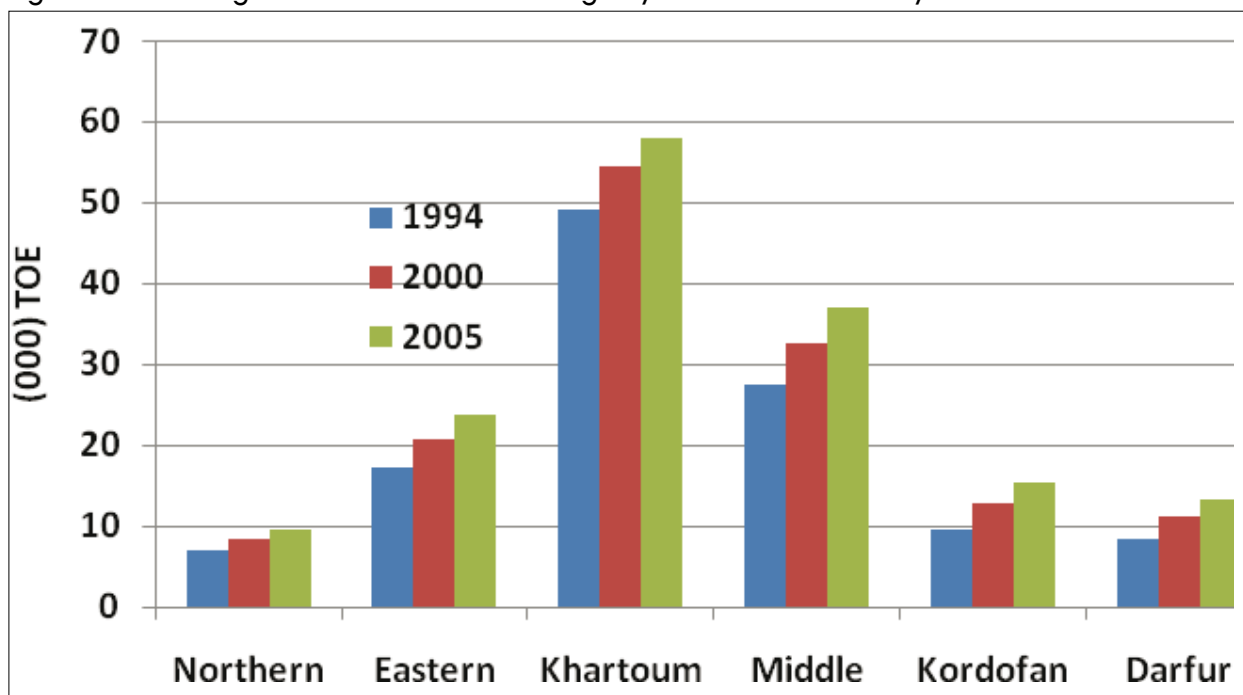

Source: Ministry of Council of Ministers (2005), Firewood Consumption and Possible Alternatives in Sudan

4) Urban Service Sector

Urbanisation features as a major driver of energy demand increase, and pushes its unsustainable character. Of the total charcoal supply, 89% is sold in urban centres (compared to 81% woodfuel popularity in rural areas).³ A large percentage of this charcoal is being used by informal tea makers. Past experience shows that it is difficult to target tea makers as possible LPG clients. Their informal status dictates a high level of flexibility for their business, and prevents most from investing in more sustainable business practices.

By contrast, restaurants could be facilitated in switching to LPG. Many of the larger ones have already started using LPG, and smaller ones could be given incentives to do so. Bakeries, which are significant users of charcoal, would be another potential target for reducing woodfuel use for urban energy. There are some 7000 bakeries across Sudan, of which 10% have made the switch to LPG. LPG-fired bakeries are particularly numerous in Khartoum, Wad Medani and Gedaref, where firewood is expensive and where they can rely on a stable LPG supply. This is different in areas such as Sennar

and El Obeid for example, where LPG prices are much less competitive.

5) Industries

The most important customers of woodfuel in urban centres are the brick kilns, and (to a lesser degree) pottery makers. The greatest amounts of bricks are being produced in central Sudan, Kordofan and, particularly since the conflict-related rural-urban migration, in Darfur. Thus far, pilot programmes with LPG-fired brick kilns have had little effect and there is limited interest by brick owners in experimenting with new technologies. One reason behind this reluctance is an economic calculation: the brick kilns industry in Khartoum faces major decline due to the increasing use of new building materials such as mud bricks, Soil Stabilized Blocks (SSB) and Cement Stabilized Blocks (CSB). Another factor lies in the irregular LPG supply. Nonetheless, the kilns' relatively high share of overall firewood consumption carries the potential to significantly reduce the brick industry's ecological footprint.

Khartoum is by far the largest city and therefore is an exceptional case. It alone consumed only 10% of the country's biomass energy in 2009. At the same time, Khartoum is the unchallenged frontrunner in LPG uptake, and charcoal and woodfuel trade is in steady

3) Ministry of Energy and Mining (2001). *Second National Energy Assessment*. Khartoum, Sudan

decline. Firewood prices have increased at least fourfold over the last decade, and LPG consumption has been on the rise since 1999. Two thirds of LPG within the city is sold to individual households (through agents), bakeries, restaurants and industries. Khar-

toum’s LPG consumption increased steadily since 2000 and now accounts for 60-65% of Sudan’s total LPG sales. In 2011, growth in the capital stands at 10% per year, if this trend continues, much of the available LPG supply would be required in the capital.

Figure 9. Brick production levels and firewood consumption in 1994

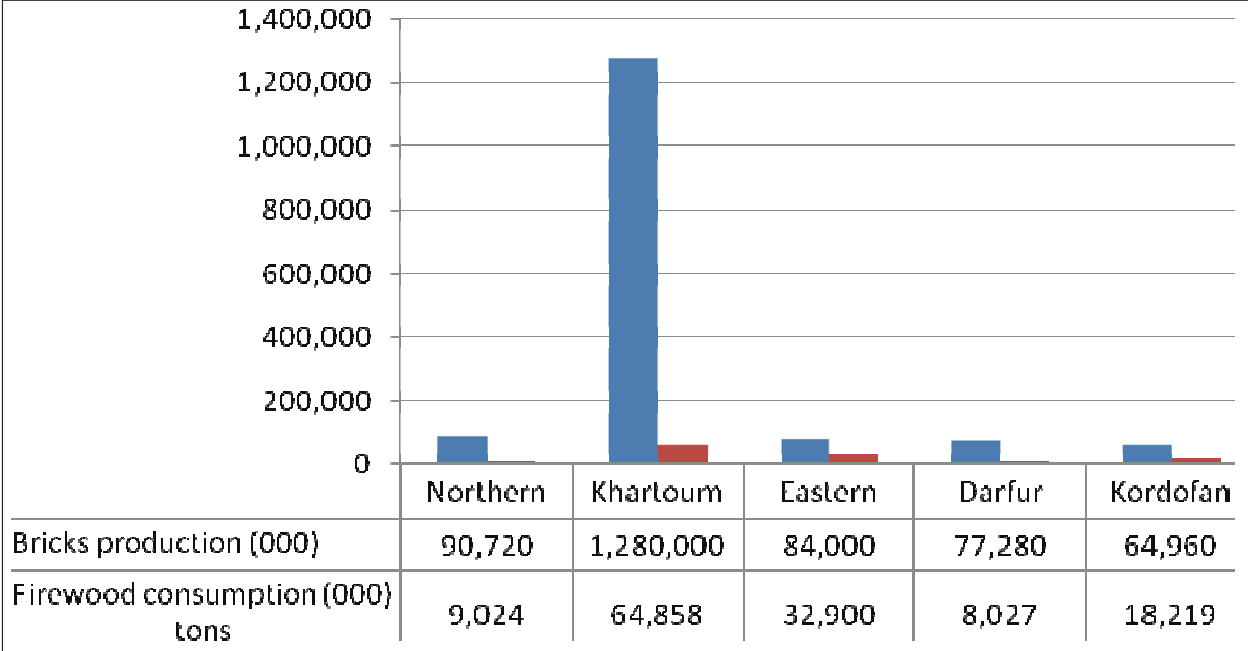

Source: Mohamed Hussein (1994), Firewood consumption by the Brickmaking Industry in Sudan. Food and Agriculture Organization, Forest National Corporation

Figure 10. Annual wood fuel usage by traditional industries and cleared forest area in 1994

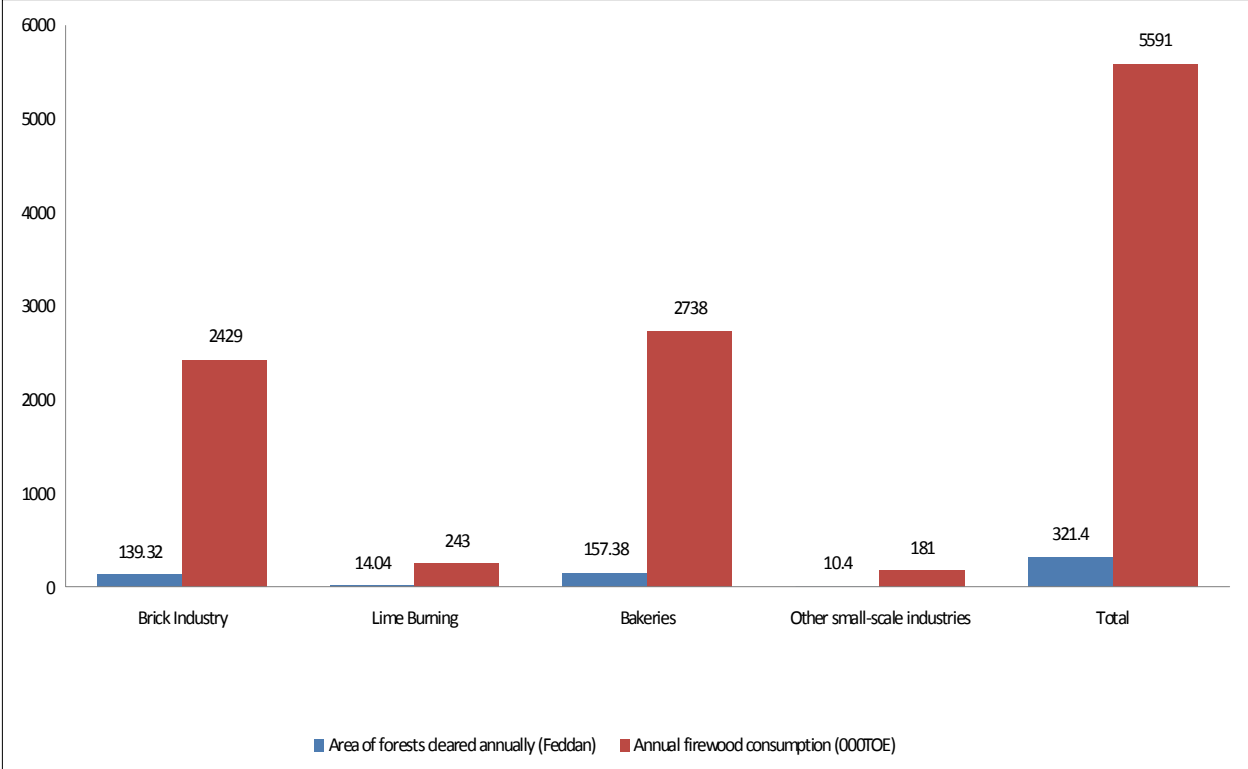

Conclusion

This section summarizes the recommendations established during the LPG workshop.

Enhance Awareness

Households are the largest and most important target group for LPG uptake, particular those living outside central Sudan. However, many potential LPG consumers have little knowledge of the dangers of wood fuel, and often do not see the benefits of LPG. Awareness campaigns are needed to explain the benefits of LPG to health, environment and safety.

Prioritise Poverty Alleviation

For many, the competitiveness of woodfuel comes from its availability in small quantities. Many households do not have the means to spend money in advance on larger quantities. Microfinance programmes and other credit schemes are key to facilitating this change. Numerous credit schemes have been launched in the past, but few have resulted in high levels of pay-back. Experience shows that microcredit to individual households can be effective if rooted within the community, with active involvement of women. Similarly, banks and LPG businesses can play an important role in breaking the financial bottlenecks that consumers face when transferring to LPG.

Regulate LPG Pricing

LPG needs to be affordable to consumers. Current prices include a significant component of transportation and taxes. In order to scale-up LPG consumption across the country, Sudan's LPG policy should be designed to provide LPG at similar prices in every region of the country. LPG is only attractive as an alternative if prices are competitive to local firewood. Flat-rate subsidies are unsustainable and should be kept to an absolute minimum. Incentives should therefore come in form of stimulus packages channelled through state authorities, targeted transport subsidies or business incentives to cater for the needs of more remote regions. Local entrepreneurs should be encouraged to become involved in local solutions where this is can enhance LPG access.

Improve Distribution

In order to make a difference, LPG supply must be guaranteed, and accessible to those who want to buy

it. In this, energy businesses again should be facilitated where possible. The federal government has a role to play in ensuring an even spread of depots across the country, and could provide co-financing for LPG companies to expand their current infrastructure. Similarly, the consumer appliances would benefit from additional investments. Firstly, safety standards for cylinders should be rigidly monitored so that old appliances are not given out to customers. Secondly, locally manufactured LPG cylinders could further increase the overall benefits from LPG uptake in each province.

Reduce Industry Footprint

The industrial use of woodfuel still stands for a significant share of overall energy needs. Brick kilns in particular are key to decreasing the biomass share of national energy consumption. Initiatives to develop appropriate technologies should be stimulated and brick kiln owners should be encouraged to engage in pilot projects. This can be done through both the state or federal ministries. UN agencies can also play a role in facilitating pilot projects in this regard.

Stimulate New Technologies

There is much more to energy policy than replacing firewood for cooking with LPG. Alternative LPG use such as lighting and electricity might – if applied effectively – offer new ways of using LPG to meet Sudan's growing energy demand. Developments in biofuels, for example or solar energy could play a complementary role in the country's off-grid energy solutions. In addition, measures should be undertaken to subsidise lead technologies. Research and studies on LPG and other alternative energy sources should therefore be supported. [Centres of Excellence such as the Energy Research Centre can assist in developing state-of-the-art solutions for sustainable energy.]

Align LPG-related Policies

Sudan's energy landscape is still fragmented. It is crucial for the coming years for the involved stakeholders to work on a policy review on how to tackle the challenges of energy demand and supply.

Improve Data Collection

Without reliable data, energy management will not succeed. Baseline data today is sketchy, and it is difficult to identify the best entry points for LPG policy. In order to do so, central coordination is important.

LPG Production: Eng. Mutamen (Khartoum Refinery Company)

KRC IN BRIEF (1)



Khartoum Refinery {KRC} is a modern refinery essentially processes Sudanese origin crude {Nile Blend} and {Fula Crude} aiming to fulfill the petroleum products demand of Sudan. It has been commissioned in May 2000.

KRC originally designed to process 2.5 M t/a of Nile Blend crude while the processing capacity was increased to 5 M t/a in two phases through processing different quality and difficult to process Fula crude.

KRC IN BRIEF (2)



The main processing units of KRC are:

- ▶ 1. Atmospheric Crude Distillation {CDU}.
- ▶ 2. Diesel Hydro Treating {DHT}.
- ▶ 3. Residue Fluid Catalytic Cracking {RFCC}.
- ▶ 4. Delayed Coking {DCU}.
- ▶ 5. Gasoline Diesel Hydro Treating {GDHT}.
- ▶ 6. Continuous Catalytic Reforming {CCR}.
- ▶ 7. Jet Refining.
- ▶ Semi Regenerative Catalytic Reforming (not in operation).

ABOUT LPG (1)



Liquefied Petroleum Gas {LPG} can be defined as a blend of Propane (C3's) and Butane (C4's) readily liquefied under moderate pressure or is the over head of the gasoline stabilizer and used as fuel in heating appliances and vehicles as well as refrigerants and at the same time provided the petro-chemicals industries with different feed stocks .

ABOUT LPG (2)



LPG is heavier than air and will flow along floors and tend to settle in low lying places which can cause suffocation or ignition hazards

LPG evaporates at normal ambient temperature and pressure and the ratio between the volume of the vaporized gas and the liquefied gas varies depending on the composition, pressure and temperature but typically around 250:1.

ABOUT LPG (3)



LPG burn cleanly with no soot and very few sulphur emissions and no ground or water pollution hazards and has been a popular choice of fuel for over 60 years due to its flexibility, convenience and environment advantages.

LPG is recognized by governments around the world for the contribution it can make towards improved indoor and outdoor air quality and reduce green house gas emission.

USES OF LPG (1)



LPG is used in the following areas:

1. **Fuels:** As Heating, Power generation, Coking...
2. **Source of Petro chemicals feed stocks:** LPG precisely that produced by the RFCC unit provides significant source of olefins particularly propylene and butylene.

USES OF LPG (2)



Propylene is a demanded feed stock for Polypropylene.

Butylene can be upgraded through:

- Polymerization.
- Alkylation.
- MTBE \ ETBE Production.

KRC CURRENT LPG PRODUCTION (1)

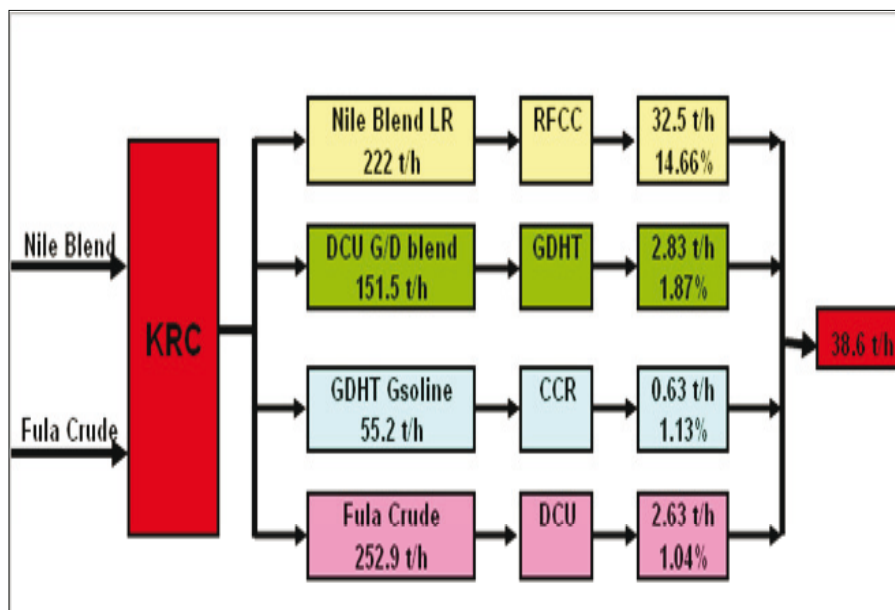

KRC CURRENT LPG PRODUCTION (2)

The daily average LPG production rate is 930 to 1000 ton. According to KRC units configuration, the RFCC unit is regarded as the main LPG producer as it produces about 32.5 ton/hr equivalent to 84% of the total refinery LPG production and can be increased to 38 ton/hr and the gain mainly depends on the feed quality, operating parameters and base octane as well as the unit limitations.

KRC is the **only** LPG producer in SUDAN.

KRC LPG PRODUCTION TREND SINCE 2000

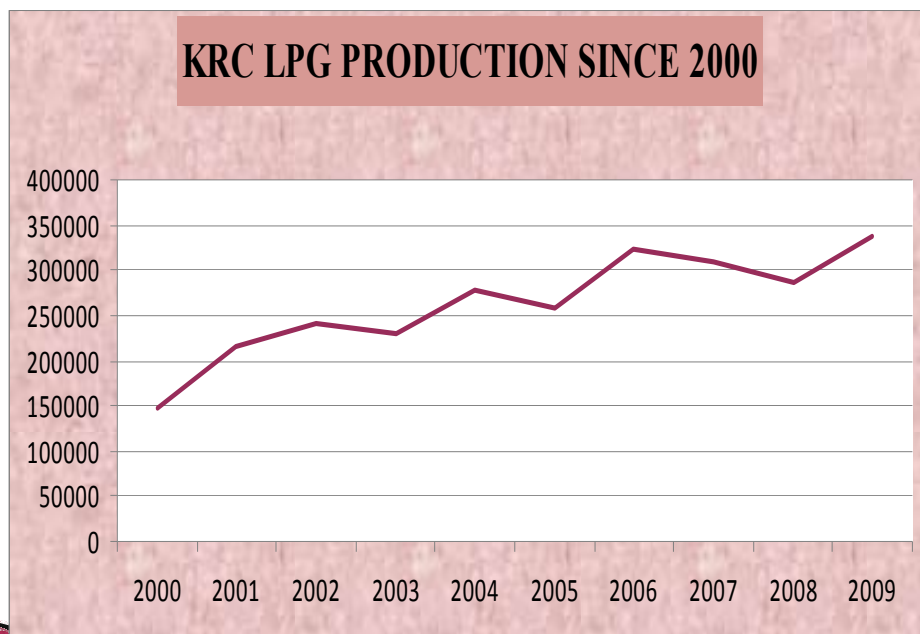

%w LPG OF THE TOTAL YEARLY CRUDE PROCESSED

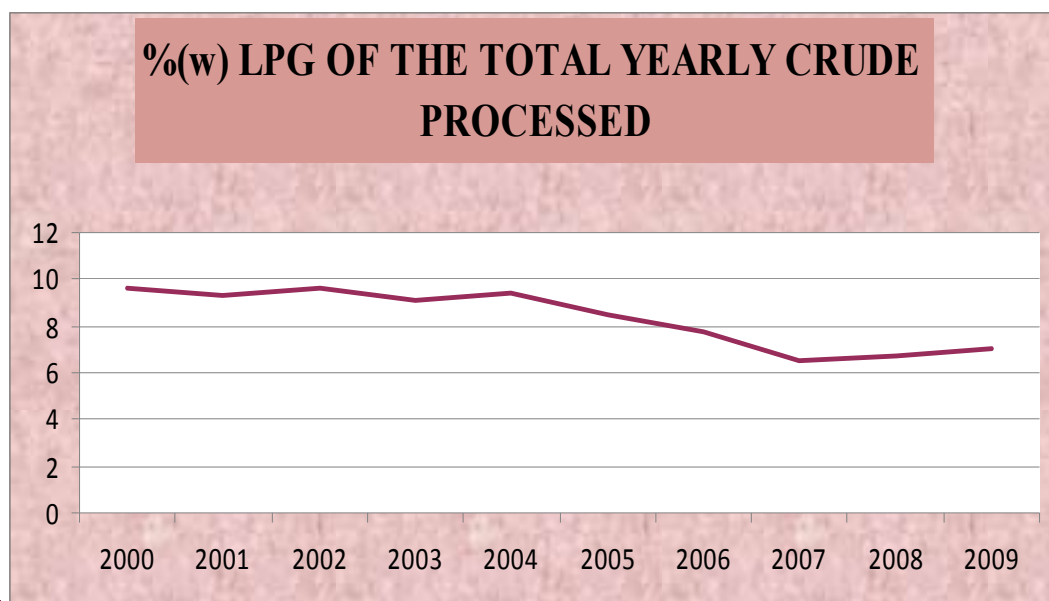

KRC LPG FUTURE PRODUCTION PLAN

(1)

For KRC, the LPG is a resultant product as maximizing the Diesel production is the priority.

KRC is planning to expand the refinery and the decision is yet to be taken and accordingly the LPG production will be increased but the increment will depend on the following:

1. Type or blend of crude to be processed.
2. Units configuration.
3. The required types of products.

KRC LPG FUTURE PRODUCTION PLAN

(2)

Studies were made for expanding KRC resulted in many options that depending on the crude and blends and at the same time the existing RFCC to be revamped to increase the LPG production. At least **277.2** K ton/a LPG would be produced above the current production rate.

LPG Supply in Sudan – Summary: Ian Thomson (Adam Smith International)

LPG supply

In the absence of any large natural gas project, indigenous LPG production ultimately derives from the oil produced in Sudan. Sudanese acreage is largely unexplored and could have very significant potential in excess of the current 6.7 billion or so barrels that BP reports as proven. In addition, there are a number of projects in all operating companies but especially in the areas operated by the Great Nile Operating Company and Petrodar to increase recovery factors, which by world norms are low.

We reviewed current plans for future oil production in Sudan but were not able to look at subsurface data or any reservoir modelling, nor has this work been based on official forecasts or data from the Oil exploration & production authority / Ministry of Energy & Mining (OEPA/MEM). It does, however, reflect the latest figures from various government sources, Sudanese oil companies and our own analysis.

For the next five or ten years, and in the absence of a major discovery elsewhere, it is assumed that production in Sudan will continue to come from four principal sources (see also figure 1 below):

- 1) "Nile Blend", a sweet but waxy crude, from Blocks 1, 2 and 4 (Greater Nile);
- 2) A heavy oil from Block 5A that is commingled with Nile Blend;
- 3) "Dar Blend", a heavy but sweet crude, from Blocks 3 and 7 (Petrodar); and
- 4) A mixture of very heavy Fula oil and some Nile-type crude from Block 6, called Fula Blend.

The LPG contained in the crude production can be calculated from known compositional assays and the predicted production volumes (see table 1).

Figure 1. Consolidated Sudanese oil production forecasts

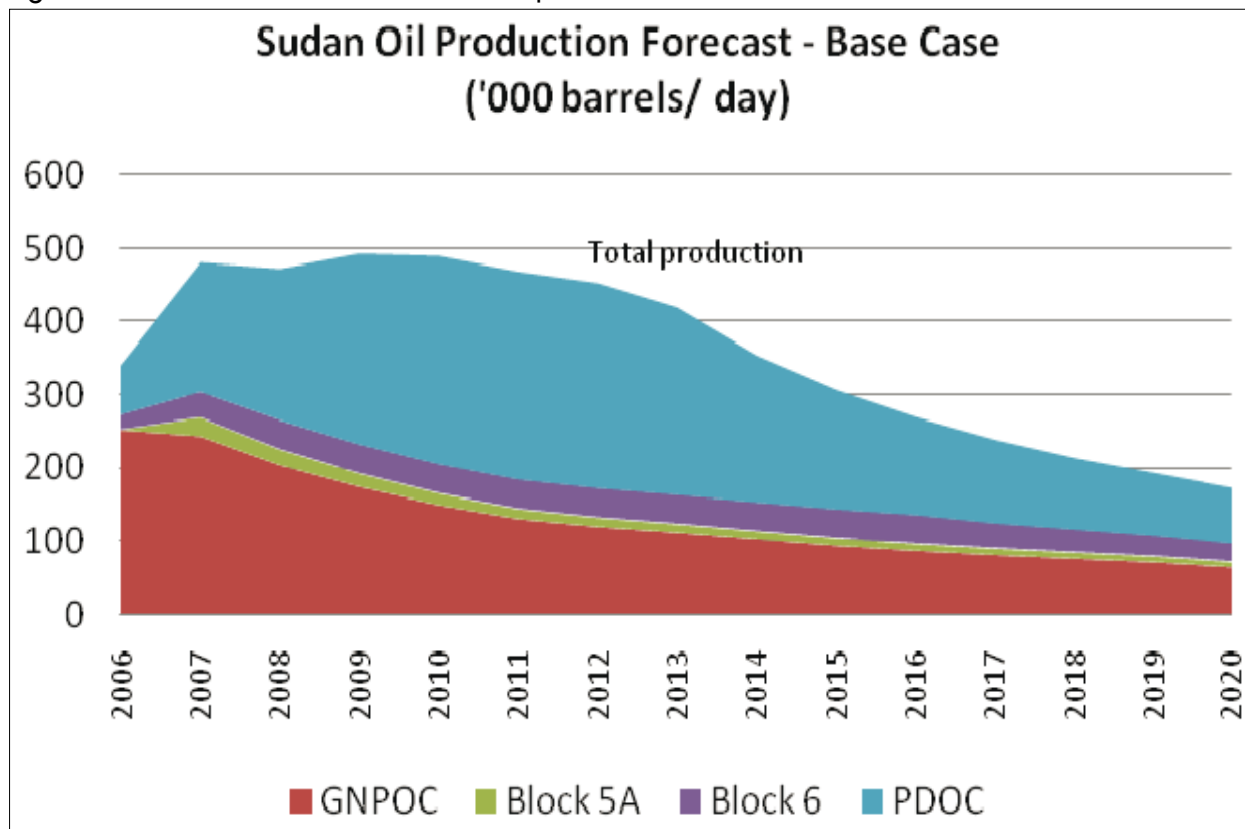

Source: ASI and Coffey Analysis

Table 1. Calculated annual LPG in crude oil and location ('000 Tons/ year)

Area	2006	2007	2008	2009	2010	2011	2012	2013	2014	2015	Location
Nile	514	496	415	355	306	267	245	229	211	192	Mainly in South
Block 5A	0	41	34	29	24	21	20	18	16	15	South
Block 6	40	70	80	80	80	80	80	80	80	80	North
TOTAL	554	607	529	464	410	368	345	327	307	287	
Dar	97	253	297	373	407	407	402	367	288	233	South

Source: ASI and Coffey analysis

Figure 2. Oil flows in Sudan (2009)

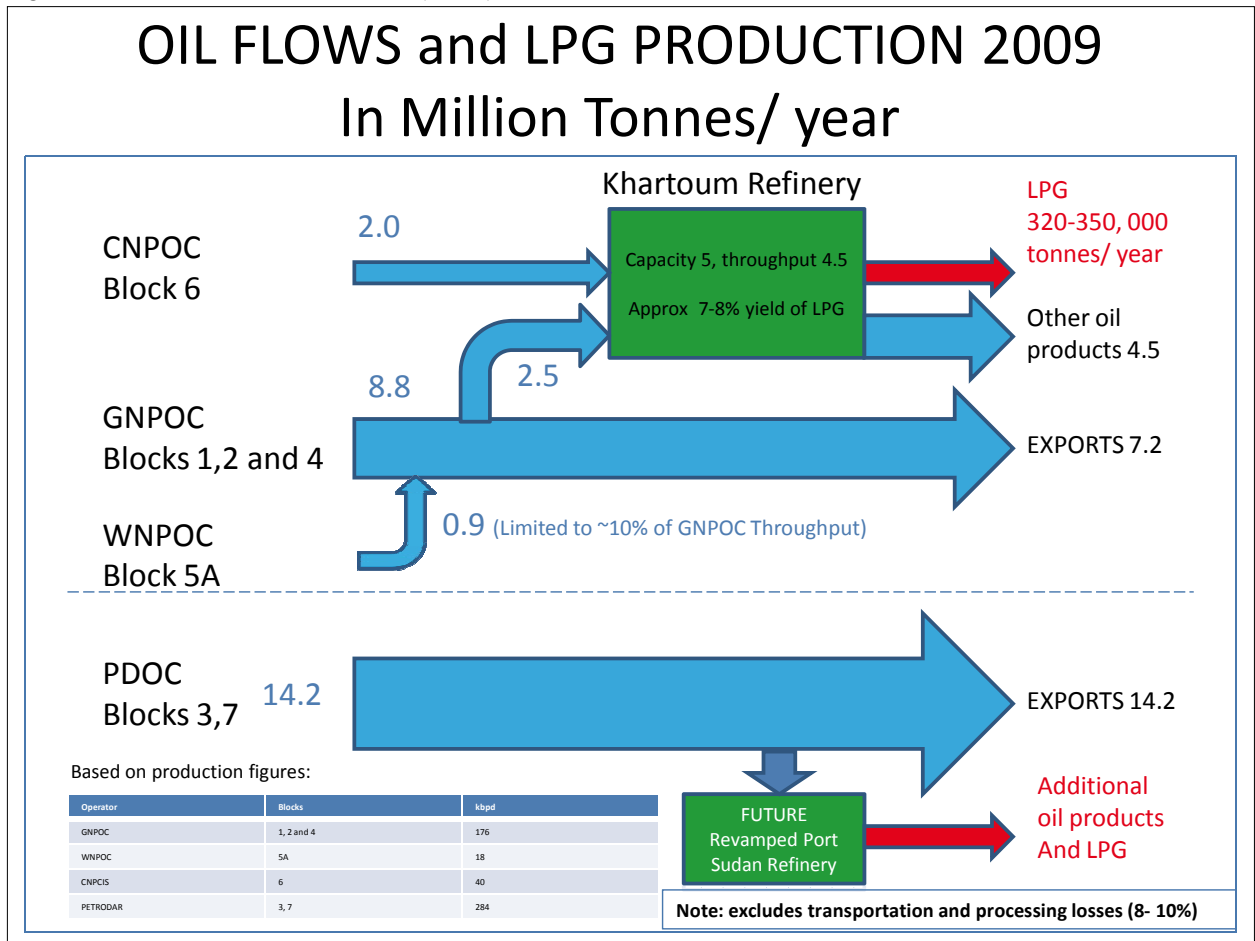

Source: ASI and Coffee analysis

Significance of the Khartoum Refinery

All of the oil from Block 6 and as much as possible of the Nile / Block 5A blend, up to a maximum of 100,000 bpd combined through-put, is sent to Khartoum refinery for processing. This oil is approximately 60/40 owned by the North and South. The refinery is understood to buy the crude it processes, so the LPG sold at the refinery rack would all be owned by the North unless post Comprehensive Peace

Agreement sharing arrangements were to apply to the refinery, or the refinery were to move to a tolling basis with risk and property in the processed hydrocarbons remaining with the original owners.

Potential from Sudanese gas

If there are significant recoverable deposits of non-associated natural gas, say 2 to 3 Tcf, as suggested by BP, this could potentially support a substantial gas project with production of the order of 200 to 300

MMSCFD; over 3 Tcf of commercially recoverable reserves near the sea might even support a single train Liquid Natural Gas (LNG) plant.

The availability of natural gas would greatly increase the flexibility of Sudan's energy supply options. A 300,000 MMSCFD gas or an LNG project (all LPG would need to be removed from the gas stream prior to chilling) might typically generate 200,000+ tons of LPG a year. The volumes of C3/C4 and C5+ would of course depend on the composition and reserves of the gas, which are not known at the moment.

The Kyoto Protocol encourages countries to offer projects that meet the challenges of applying clean development mechanism (CDM) and joint implementation (JI) eligibility criteria, including the reduction of gas flaring. However, gas gathering systems can be very expensive, especially for low GOR (gas:oil ratio) oil, as is the case for most oil in Sudan. It may also be possible to collect some LPG that would otherwise be flared via skid mounted equipment that can be moved from site to site. However, this would not capture the valuable C1/C2 stream.

The volume of LPG that could be produced depends on the specific scheme as well as the composition of the flared gas, but could be several thousand tons per year. This could greatly assist with the supply of LPG in the South. A pre-feasibility study should be undertaken by MEM and GOSS MEM as soon as possible.

LPG from Sudanese refineries

Khartoum (Al Jaili) Refinery

First commissioned in mid-2000 with a capacity of about 50,000 bpd, this refinery was built and is operated by China National Petroleum Company (CNPC). The capacity of the refinery was increased to about 60,000 bpd in 2004 and to 100,000 bpd by the autumn of 2006. The new cracker allows the refinery to produce a greater proportion of higher value lighter products, including LPG. Actual production of LPG appears to have been in the range 320,000 to 350,000 tons per year since 2007, although CNPC sources say that the capacity for LPG production is now 420,000 tons per year. The reason for this apparent discrepancy is that utilisation factor at the refinery is of the order of 80 to

90%, which is high by African norms (75-80% would be more typical).

The LPG produced by the refinery comes from three main sources:

- in the crude oil, less than approximately 4% by mass;
- from the Residue Cat Cracker (RCC), perhaps amounting to 2-5% of total refinery feed, so maybe 6 to 15% of the RCC feed;
- there may also be some from the reformer, but likely to be very little.

This would give around 7-8% yield of LPG from the crude, or about 350-400,000 tons per year of LPG production potential. This is double the percentage of LPG yield if Khartoum were a simple straight run refinery.

CNPC has developed a polypropylene plant at the El Jaili complex, with a nominal 15,000 ton production capacity and a plastics factory with annual production capacity of 20 million plastic bags and 16 million square metres of plastic films. In addition some LPG is used for a back-up fuel for some power stations. In total these uses may remove up to 15,000 tons per year of LPG from the local market supply. In summary, approximately 325,000 to 350,000 tons of LPG annually is available for the Sudanese market from the Khartoum refinery complex.

El Obeid and Port Sudan refineries

El Obeid and the remaining operational facilities at Port Sudan produce virtually no LPG. If Port Sudan is upgraded to improve the value of Dar blend oil, a new modern 50,000 bpd refinery might produce up to 100,000 tons of LPG a year.

Port facilities

Sudan has two main oil export terminals on the Red Sea, Bashair-1 and Bashair-2, both south of Port Sudan. The first serves GNPOC exports from Blocks 1, 2 and 4 together with production from Block 5A. The second port handles PDOC production from Blocks 3 and 7. Bashair-1 port can import or export LPG and is connected by pipeline to the Khartoum refinery.

LPG supply and demand balance

LPG demand range

The Demand Team will be preparing forecasts of total LPG demand and demand by market sector. In the absence of such forecasts, we rely on SPC's official forecasts (supplied by one of the LPG companies), which are as follows (see table 2). The SPC's LPG demand forecasts are evidently based on 5% year on year increase. This can be compared with the 10 to 15% annual growth in the period 2001 to 2010. With approximately 50% subsidies on LPG prices likely to continue, the SPC's forecasts are probably on the pessimistic side unless and until there are real LPG supply constraints from the refinery or the downstream infrastructure.

LPG supply scenarios

The present indigenous LPG supply is limited to that which can be produced at the Khartoum refinery minus whatever is used in the polypropylene plant and for power generation back up use. Provided that more than 100,000 bpd of production can be maintained from Blocks 1, 2 and 4, 5A and 6, which is likely to be the case for at least 25 years, and as pointed out elsewhere, the supply of LPG available to the local market net of plastics and power use will continue at around 325,000 to 350,000 tons per year (although the nameplate refinery LPG capacity appears to be around 420,000 tons per year).

LPG imports and exports

The balance between total net supply and total net demand is achieved by means of exports or imports. There are some imports of LPG into the south from Kenya and Uganda, and very limited exports in cylinders to Ethiopia by Nile Petroleum under licence.

NPC supplies export customers through the Al Jailli depot on an FOB basis so no specific facility is designated for exports. The export customers use their own road tankers to transport it to Ethiopia. Aman Petroleum does the same. The bulk of the country's LPG exports have been handled by the Gas Export Company, GECO. The government re-nationalised the majority of the export facilities from companies like NPC and Aman Petroleum in the early 2000s, so as to concentrate on the LPG export business in the hands of the State.

LPG supply and demand balance

Even with only 5% growth, local LPG demand will outstrip supply by 2013 or 2014 and from that point onwards, LPG will need to be imported to make up the shortfall. This LPG will need to be paid for at international market prices. Unless LPG prices continue to be subsidised, this could impede further demand growth rates. Whether SPC should continue to act as the channel for such indirect subsidies is another matter.

Table 2. SPC official demand forecasts for white oils and LPG (tons)

Year \ Product	LPG	Gasoline	Jet	Gas Oil	Fuel Oil
2009	280,574	606,299	247,163	2,876,858	496,068
2010	294,603	636,614	254,578	3,164,544	520,871
2011	309,333	668,445	262,215	3,480,999	546,915
2012	324,800	701,867	270,082	3,655,049	574,260
2013	341,040	736,960	278,184	3,837,801	602,973
2014	358,092	773,808	286,530	4,029,691	633,122
2015	375,996	812,499	295,126	4,231,176	664,778
2016	394,796	853,123	303,980	4,442,735	698,017
2017	414,536	895,780	313,099	4,664,871	732,918
2018	435,263	940,569	322,492	4,898,115	769,564
2019	457,026	987,597	332,167	5,143,021	808,042
2020	479,877	1,036,977	342,132	5,400,172	848,444

Source: Aman Petroleum

LPG distribution

Main players

There are seven main companies operating in the Sudanese LPG market. All of them buy LPG from Khartoum refinery at regulated and subsidised prices. As LPG supplies to date have been in surplus, there has been no need for long term supply contracts. The principal LPG companies are: Aman Petroleum, Nile Petroleum Company and Abbarci Gas. AGIP, Shell and Total all exited in the 1990s.

Aman Petroleum took over Shell's LPG business in 1996, including all depots and cylinders.

The *Nile Petroleum Company* (NPC) was established in 1954, and was known then as the Egyptian French Company for Petroleum. It passed through a number of trade names as a branch of Caltex Company, then as a branch for Total International Company, and known later as the Nile Company for Oil Import and Trade (1978), in partnership with the Government of Sudan. At that point the Government owned 75% of the company's shares. In 2003 NPC became 100% government owned and is considered to be the sole arm for the Ministry of Energy and Mining (MEM) in distributing and marketing petroleum products. It provides this service to all sectors through an integrated storage and delivery system from its main depots in Al-Jaili, Al-Shajara and Port Sudan.

Abbarci Gas started its business in 1993. Abbarci's website (www.abbarci-sd.com) says that it was the first Sudanese company in LPG. It is privately owned and reportedly pursuing aggressive marketing tactics to build market share. At present its market share is equal to and will shortly exceed that of NPC and Aman.

Regulatory system

MEM licenses and regulates the operation of all the main LPG companies. Any exports require special licences from MEM, which are provided on a case by case basis. Prices are set throughout the country by the SPC but actual end user prices include a high transportation element and the amount of economic rent in the supply chain varies throughout the country. SPC also regulates all technical matters in the industry.

Market structure

The bulk market is about 5% of the total market mainly for industrial and commercial customers, although some domestic customers have tanks. Customer bulk LPG tanks are usually 0.5 to 5m³ capacity. The remainder of the LPG business is by means of cylinders, mainly 12.5kg and 25kg but with some 2.5kg, 4kg and 6kg.

Infrastructure

NPC provides its LPG services to consumers through the major depots in Al-Jaili, Al-Shajara, Port Sudan and Wad Medani, in addition to regional depots across all northern Sudanese State, at Port Sudan, Medani, Atbara, Sennar, Kassala, Gedarif, Rabak, Al-Fasher, Nyala, Dongola and Al-Obeid. NPC has a mobile filling station and four mobile units used by accredited agents who distribute and markets LPG to the various regions. NPC has over 1,500 agents.

The other companies have a similar spread of depots and logistical networks. For example Abbarci started with two filling depots at Shagara and Port Sudan but it now has more than 20 depots in the North. There is a plant to refill cylinders (used jointly by Aman and NPC) in the South. GOSS sees an urgent need for a LPG supply pipeline as in Egypt and elsewhere but the economics are likely to be very disappointing given the high costs of such a scheme and the low volumes, leading to high unit costs.

Cylinder availability and management

Aman has about 500,000 cylinders; NPC told us that it has approximately 620,000 12.5 kg cylinders. Abbarci say that they have 1,000,000 12.5 kg, 12,000 25 kg and 3,000 50 kg cylinders. We therefore estimate that there are probably about 2.5 to 3 million cylinders in circulation in Sudan. Many cylinders are ex Shell, AGIP or Total and are old. Abbarci is building a factory to make cylinders and up to 3,000 domestic tanks a year.

Cylinders can only be filled at approved bottling plants – there are regulations in force that prevent cross-filling except by special written agreement. This significantly improves safety. The bottling plants also check the cylinders for wear and age and remove them from circulation if they are not safe.

Consumers pay approximately 125 SDG as a “deposit” the first time they purchase a cylinder (this figure comes from NPC – Abbarci is understood to be under-cutting this price). The deposit on cylinders is of course one of the main deterrents for the uptake of LPG.

Pricing

LPG is purchased by licensed LPG companies from Khartoum refinery at approximately 10 SDG per 12.5kg cylinder, irrespective of international prices. This figure is regulated by SPC. 10 SDG per 12.5kg works out at US\$341.6 per ton, compared with current international prices of around US\$720 per ton (1 SDG = US\$0.427 as at June 2010). The subsidy is over 50%. We understand that LPG in 12.5kg cylinders is priced at between 12 and 15 SDG in the Khartoum area, usually around 13 SDG. LPG in Darfur is priced between 31 and 42 SDG for a 12.5kg cylinder: Nyala, El Fasher and El Geneina. Prices at Sennar could be as low as 16 SDG.

Distribution from Khartoum to outlying districts is very costly due to poor road transport conditions. Rails cars are not used for LPG in Sudan. LPG selling for 12 to 15 SDG in the North was on sale at 60 to 70 SDG in the South (according to GOSS), so although the basic price is supposed to be regulated across the country, the end user price of LPG is much higher in the South than the North.

In 2006, the UN Joint Logistic Centre identified the transportation cost from Khartoum to Sennar as US\$26 to US\$46 per ton with an average of US\$36.28. Adding say 15% for inflation since 2006, this gives an average price of approximately US\$54 per ton, which, assuming the margins for same storage, bottling and marketing margins as in the Khartoum area, fits with the analysis that LPG prices are essentially set by cost of supply considerations. This estimate needs to be revisited after the workshop, as transportation in cylinders rather than bulk to outlying areas needs to be adjusted for the costs of transporting the steel.

Looking at the Darfur region, the transportation costs from Khartoum to Nyala as US\$156 - 158 per ton, to El Fasher as US\$158 - 173 and to El Geneina, in the far west of Darfur, as US\$291 to 301 per ton. Again, allowing 15% for inflation, the average transportation costs would be US\$180, 191 and 340 per ton respectively. Even allowing for a further 20% for additional storage and distribution costs, for example,

this means that the LPG prices in these locations are substantially in excess of the costs of supply. We were told unofficially that there are serious issues in outlying districts such as Darfur where the state and local authorities charge additional levies / taxes on LPG transportation and on the refilling depots. There are also concerns over physical risks for shipments. Our team was unable to visit Nyala, for example, because of raised security concerns.

Currently very little or no bulk supply reaches the South due to extended journey times and the lengthy journey (two weeks), which is usually done by barge. The costs of transportation to the south are very difficult to quantify and we need additional data. For years, the River Nile was the only North-South route open year round, although a relatively reliable but poorly paved road connection was established in 2008. Barges can carry large loads, between 200 and 500 tons, or the equivalent of between 10 and 25 tanker trucks and the route exists and is free of the effects of the rainy season.

However, the lack of barges, the poor state of the pushers, the need to transfer loads at Kosti where there is a cataract and the inadequacy of the river ports will continue to severely limit the attractiveness of this corridor. In principle there is no reason now for the actual costs from Khartoum to Juba to be more than about [US\$350 to 400 per ton] even by road given the relative distances to Darfur. So again, the very high costs of LPG in the South cannot be explained in the pure cost of supply.

Our provisional view is that the marginal cost of LPG supply in the South is being set by imported LPG from Kenya. In partial support of this, we note that a draft review on energy access for urban poor in Kenya for Global Network on Energy for Sustainable Development (GNESD) dated May 2008, gives the cost of refilling a 6kg cylinder as US\$13. If this is the case, then the *pro rata* costs of filling a 12.5kg cylinder would be $13 \text{ SDG} * (12.5 / 6) * 2.24$ at present exchange rates = 60 SDG.

Transportation and other margins would increase the price a little. This is close to the price we were told by GOSS MEM that LPG is selling at in the South. Companies like Aman, NPC and Abbarci need to be persuaded that the rewards outweigh the market risks of doing business in some of these districts.

Potential for scale-up of LPG

Scaling up indigenous supply of LPG

The main obstacle to expanding the supply of LPG in Sudan is that the refinery cannot produce more than 420,000 tons of LPG per year; and depending on the crude runs the actual production figure is considerably less. Ultimately any shortfall in supply can be made up by importing LPG.

Four possible ways of increasing indigenous supply are:

- Possible further expansion at the Khartoum refinery;
- revamping Port Sudan refinery;
- a major natural gas development; or
- collecting LPG from gas that would otherwise be flared.

Further downstream, the ability to expand and reinforce the LPG supply system will depend greatly on the availability of storage and filling depots in the right places, transportation such as bulk vehicles and the cylinder stock. Since 2005, depots have been established across all northern states, although much of the storage is still concentrated in the largest depots at Al-Jaili, Al-Shajara, Port Sudan and Wad Medani. The main LPG companies have separate depots at these locations.

There is no reason to doubt that the major LPG companies have sufficient financial strength to consolidate and further extend their markets in the North, although NPC may in practice have certain constraints imposed on its investment strategy due to its government ownership. A significant scale-up of LPG use would require expansion of the capacity of storage depots, bottling capacity, logistics and geographic coverage, particularly to provide improved LPG access to regions in the south and west. More depots may need to be built closer to the end markets.

The second main impediment to the development of the LPG market away from Khartoum is the high end user costs of LPG, particularly in Darfur and the South. Abbarci appears to have made major progress in supplying LPG up country in the North. However, the volumes in Darfur and the South are

relatively small and there appears to be no great incentive for the LPG companies to concentrate on developing markets in those areas.

There is very little storage and bottling capacity in the South and LPG prices appear to be inordinately high, which will act as a major inhibitor to further demand growth, the more so as the income per capita in the South is considerably less than in the North. Steps need to be taken to reduce the huge price differential of LPG between the South and the North and to increase availability and reliability of supply. The price differential is not easily explained in terms of the additional logistical costs.

Policy issues

There are a number of policy issues that cut across different government departments, state level agencies and provincial and local government bodies.

- Lessons from pilot studies: Some of the detailed policy issues and lessons from pilot studies have already been identified by the demand team. The recommendations of other pilot schemes e.g. Nyala brick works need to be taken on board by policy-makers. Practical "action interventions" recommended for Eastern Sudan and Darfur should also be adopted in the South as well.
- Prioritising and facilitating use in households including promotional policies involving education. LPG scale up activities should directly address women, as cooking fuel procurement and use are largely the responsibility of women in the Sudanese households. There needs to be greater public awareness of the health and environmental benefits of conversion to LPG (indoor smoke inhalation can lead to serious illnesses).
- Fiscal issues: Federal level taxes have been removed from domestic appliances but at state level taxes are still levied on the transport of LPG. There is also a more general issue of managing the taxation and licensing costs imposed on depots by state governments.
- Subsidies: There are subsidies of around 50% on the basic price of LPG bought from Khartoum refinery. This costs around US\$100 million a year

(ASI estimate). When LPG supply is no longer in surplus, LPG will need to be purchased on the open market and imported to make up any shortfall. The LPG will need to be purchased for hard currency. How these subsidies will be channelled (possibly through SPC) needs careful thought. Subsidies on transport fuels and LPG (unless offset by higher taxes) mean less government spending on other services – like schools, hospitals, roads etc. To the extent that real activity multiplier effects exist, they are likely to be significantly larger for more schools and hospitals – and larger still for more teachers and nurses. If the subsidies are financed by higher debt, it imposes costs on future Sudanese e.g. by raising interest rates. Large net subsidies will also threaten higher (general) inflation depreciation of the exchange rate.

- The “microfinance” / “microcredit” systems are effective and facilitate households to access to LPG appliances and cylinders. The schemes need to be based on full cost recovery. Cylinder refilling shops within the residential areas will further encourage households to switch to modern fuel use.
- LPG Companies, agencies, retailers must be given training regarding LPG safety procedures and regulations. Public institutions like the Nile Petroleum Company, FNC, and Ministry of Health and Civil Defence must assume key roles in project implementation.
- Monitoring LPG sale prices is necessary to ensure the LPG agents are not imposing exces-

sive retail prices and that transportation costs are properly understood.

- Regarding supply, there are a number of key policy areas and decisions that need to be addressed to ensure the availability of adequate volume of cheap LPG and the sustained expansion of LPG distribution network, depots, transportation and retail / refilling shops.
- For the foreseeable future, the principal source of indigenous LPG will be Khartoum refinery (some LPG is imported in the South). While further upgrading of the refinery would increase LPG supply and stave off the need to import significant quantities of LPG to make up any shortfall in supplies, any upgrading depends on a number of factors that are outside the control of the LPG industry. Normally such an investment decision would flow from the transport fuels market but in the case of Sudan, the decision almost certainly hinges on the need or otherwise to process more Block 6 crude and this in turn is driven by Chinese investment strategies.
- The issue of whether a refinery is needed in the South is charged with political considerations as well as questions over access to market and is beyond the scope of this report.
- Sudan should set up an LPG Association to consolidate the various initiatives at an industry level and also to act as the repository of industry standards to minimise safety risks, including the regulation of gas installations.

LPG Demand in Sudan – Summary:

Ahmed Hood (UNEP Consultant)

Forest cover in Sudan has decreased by nearly 50% since 1973. High dependence on biomass energy, agricultural expansion and desertification are major reasons for this development. In some parts of the country the problem is often exacerbated by the long-running conflicts resulting in high population density around urban areas and the resulting shift in livelihood strategies (from agriculture to firewood collecting for example).

LPG is a much cleaner and more efficient energy resource, and can play a crucial role in sparing forests from being cut for firewood usage. LPG use in Sudan therefore carries the potential to fight the alarming trend of deforestation and should be considered in Sudan's future energy policy.

Even though LPG should not be considered a silver bullet, it offers part of a short-term solution to Sudan's energy challenges in the coming years. This paper gives an overview of the issues related to wood based energy use in Sudan and looks at the policy options for LPG substitution and its potential scale-up.

Recent history

The recent history of overall energy consumption in Sudan is characterized by the start of domestic petroleum production in 2000. This led to an increase in the usage of petroleum products from 20% to 36% of overall energy consumption between 2001 and 2009, and additional major investments in electricity production through hydro-power. As a consequence, biomass use for overall energy needs decreased from 78% in 2001 to 63% in 2009. Yet, this amount still has a significant impact on the natural resources in Sudan, as all firewood related trade is unsustainable.

Forest resources are being cut much faster than they can grow back, and some 50% of the country is under different stages of desertification at the time of writing. In addition, Sudan's energy balance suffers from major losses due to refining processes, distribution losses and biomass conversion losses (mainly regarding charcoal production). In 2008,

Sudan's final energy consumption accounted only 9.8 mTOE, while energy supply stood at 14.9 mTOE. This represents a loss of more than one third of overall resources.

The distribution of biomass energy consumption splits between the three main sectors households, industry and services. Data shows that the household sector has long been the dominant consumer of biomass. It accounts for 68% of the total in 1999, while the services and industry sectors are good for 21% and 11% respectively. Since then, little has changed. The 2008 data shows a similar distribution between the sectors.

Overall, wood tops the list of type fuels (63% of total energy consumption in 2009), followed by charcoal (20%) and residue (17%). While in general, it can be said that charcoal consumptions is highest in urban centers (89% of households) and firewood is most popular in rural areas (more than 81%), many households use a combination of energy resources for their daily needs (but for example electricity only accounts for less than 3% of total household consumption). In contrast, the industry sector uses residues in the sugar industry, and firewood is needed for the rural oil/soap factories across many rural towns in the country.

Brick kilns are also booming, due to economic development, rural-urban migration, and the presence of the international community (in the three Darfur capitals and Khartoum). Khartoum is by far the most dominant consumer of brick. It should be noted here that brick production from Khartoum and central Sudan accounted for 62.7% of the total of 182,962 tons of wood that were consumed in 1994.

Other major industries include bread-making and lime-burning, which are both particularly strong in and around Khartoum. The services sector generally splits into formal and informal businesses, using a total of nearly three million tons of charcoal and firewood in 1999.

Due to widespread biomass use, Sudan faces serious environmental and health issues. Sudan's

forest resources have long been over-harvested for energy needs, and annual depletion by far outpaces cutting quotas. This unsustainable use of biomass energy is most alarming in Northern Darfur and Northern Kordofan, where desert encroachment has long been a heavy burden for people's livelihood strategies. Industry (mainly brickmaking and bakeries) consumption of biomass requires massive amounts of wood resources, a major driver of deforestation in central Sudan.

This is exacerbated by the fact that firewood and charcoal are transported over long distances, decreasing the net energy value even further. The resulting greenhouse gas emissions also represent a serious pollution of Sudan's atmosphere. Nearly all biomass burning technologies used in Sudan have low burning efficiency and therefore lead to much greater levels of CO₂ emissions from the much more polluting gases methane and nitrous oxide.

Regarding challenges to public health, Sudan faces a major challenge in poor indoor air quality and the associated health risks. Any indoor biomass use for cooking results in a 20 times higher level of air pollution than recommended by international WHO standards. Statistics show that poor indoor air quality is responsible for nearly half the death of under 5-year olds; and lead to many related deaths among older children and adults.⁴ In contrast, the use of LPG (high energy density) has much better combustion characteristics and high efficiency and leads to negligible levels of indoor air pollution.

Sudan's policy makers have been trying to amend the negative consequences of today's energy balance. After some reorganization among the different agencies over the last 10 years, in 2010 key stakeholders in the North Sudanese energy sector include the three Ministries for Petroleum, Mining and Electricity respectively.

The Ministry of Petroleum is in the lead to formulate and implement energy policies, in close consultation with the other ministries. The Ministry of Finance is involved due to the significant subsidy schemes for petroleum products and electricity introduced in

the early 2000s, and Civil Defense plays a role as it is responsible for the safety (standards) of petroleum production, transport and distribution. In addition to these ministries, there are three public corporations that are at the centre of Sudan's energy sector.

First, the National Electricity Corporation (NEC) is responsible for generation, transmission and distribution of electricity. Second, the Forest National Corporation (FNC) is in charge of the wood resources' protection and management and runs state offices with the task of supervising the supply and demand of firewood and charcoal. Third, the Sudan Petroleum Corporation (SPC) runs all aspects of the petroleum industry, from first exploration to final end use. Closely related to the SPC, the Nile Petroleum Company controls 52% of the petroleum products distribution, and is also the main handling agent for LPG.

Also, various civil society organizations – both national and international – have been increasingly engaged in the energy sector, working on the promotion of LPG usage.

Previous energy policies

Reviewing Sudan's past energy policies, it is possible to distinguish two major phases. The first National Energy Assessment (NEA) was done in 1981, which focused on increased efficiency of biomass resources to counter what was already perceived as an environmental crisis. The second NEA energy assessment in 1999-2001 incorporated the new petroleum resources into the energy mix and included a number of key priorities: reliability of supply, environmental conservation, cost efficiency, promoting of new technologies and capacity building within the energy sector.

As part of the second NEA's energy policy, major efforts have been undertaken to substitute LPG for biomass fuels with a particular focus on the household sector.

The advantages of LPG for family homes are numerous, and include economic benefits, greater diversity of modern appliances, easier storage, time efficiency, additional opportunities for service industries, improved indoor air quality and lower levels of green house gas emissions.

4) World Health Organization (2009). *Global Health Risks: mortality and burden of disease attributable to selected major risks*, WHO. Geneva, Switzerland

Sudan's LPG scale-up policy thus far has led to:

- 1) 50% subsidy on the price of LPG, set at the refinery gate;
- 2) tax exemption for import of LPG appliances (VAT still applied);
- 3) political commitment to safeguard reliable supply; and
- 4) price stability.

The greatest impact has been seen in Khartoum (about 70% of LPG is consumed in the capital) and Gezira State. At the same time, other areas in Sudan have until 2010 remained far behind in terms of LPG usage. Two other problems of this policy rest in the fact that there are major differences between final end use prices of LPG between different localities, and that local state taxes often counter the federal subsidy and tax exemption policy. Also, there remains a major bottleneck as far as LPG supply is concerned. Due to limitations in LPG production, the government in 2008 banned LPG use in the industry (excluding bakeries) and automotive sectors.

Over the years, many initiatives have been deployed in order to enhance LPG use, with varying results. In 2002, for example, the FNC, and Sudagas launched a LPG cylinder distribution scheme, which eventually came to standstill due to logistical, distribution network and technical problems.

In 2005, the international NGO Practical Action started a household indoor air pollution project in Kassala. The project beneficiaries opted for LPG and the significant reduction or elimination of indoor air pollution. The project, working with women groups, introduced microfinance as an effective means to facilitate households' access to LPG appliances. The project collected valuable lessons regarding the importance of the local context and resulting bottlenecks to LPG scale-up.

Khartoum state promoted the service sector to switch to LPG in a relatively successful campaign which led to a major boost in LPG usage in the city. A much less positive project aimed to distribute LPG appliances to tea-makers in the capital. Due to the fact that state authorities continued to consider the tea-making business as illegitimate, lending schemes for LPG-related financing proved unattractive to most potential beneficiaries - women.

Benefiting from its Kassala experience, Practical Action started a more recent project in 2008 in El Fasher, and was aimed at helping households to stop using woodfuel by introducing a microcredit scheme. This project has, until 2010 reached nearly 3000 beneficiaries and has achieved payback rates around 95%. Another initiative supported by OXFAM America included two IDP camps in El Fasher, led to increased awareness among residents but ran into problems regarding the availability of LPG supply.

Some initial projects trying to introduce LPG use for brick kilns in Khartoum and Kassala did not result in significant savings for the kiln owners, but provided some lessons learned in how to use LPG in clamp kiln firing. A different type of project, the Green Bakery project by Sayga Mills, is more marketing-oriented and links financial support for LPG appliances to bakery owners to purchase guarantees for the Sayga Company.

Barriers

Despite these various efforts, major barriers to widespread use of LPG remain. On the supply side, the LPG production in the existing refineries is much lower than needed in case of a significant rise in demand. Imports would be needed in the short- and medium term. On the demand side, the most important reasons for not switching to LPG can be found in the fact that economic considerations often work against the choice for LPG. First and foremost, the high upfront costs are prohibitive to many (a cylinder costs ten times as much as filling it) and seem a too high risk to take for potential new LPG users. Second, firewood is still competitive for daily consumption and is available in small quantities, a very important consideration for poor households.

Additional reasons not to switch to LPG in Sudan's more remote regions include the poor distribution infrastructure (and therefore higher prices), lack of public awareness on LPG usage, and a general reluctance to adopt new technologies.

Recommendations

Learning from international examples such as Brazil, India, or Senegal, Sudan would greatly benefit from

widespread introduction of LPG on the household level, including economic, health, environmental and lifestyle benefits for the individual families. It would also contribute to achieving the Millennium Development Goals.

In order to scale-up the use of LPG in Sudan, a range of demand-side interventions towards the household could lead to significant results. Importantly, these efforts should be informed by the local context, and should be organized through microfinance schemes for women as the key counterpart in each household.

It is therefore recommended that the national government focuses on demand-side interventions. Appropriate measures to consider would include:

- 1) Removing VAT for and introducing quality standards of LPG appliances;
- 2) Increasing access for poor households to credit schemes;
- 3) A public awareness campaign on health and environmental dangers of woodfuel usage;
- 4) Initiating educational efforts to handle LPG for cooking indoors;
- 5) Introducing regulatory incentives for local LPG appliance manufacturers/importers;
- 6) Encouraging non-state actors to promote LPG use;
- 7) Reviewing the current subsidy scheme to ensure that poor households benefit from the policy; and
- 8) Increasing LPG availability and supply.

LPG Use in Khartoum: Margie Buchanan-Smith (UNEP Consultant)

The Ministry of Energy (MoE) estimates that biomass currently meets about 65% of Sudan's energy needs (compared to 78% in 2001⁵). Much of this is consumed in the household sector, particularly due to firewood usage. In the city, the situation is different. Within central Khartoum and most of the older parts of the three cities, LPG has replaced firewood as the major source of energy. However, Khartoum still consumes around 10% of Sudan's biomass energy (Hood 2009), mainly due to charcoal usage. According to the Second National Energy Assessment, Khartoum in 2001 had the lowest per capita consumption of firewood in the country, but the highest per capita consumption of charcoal.

Domestic households are the main consumers of LPG in Khartoum, followed by bakeries, restaurants and factories (especially the food industry, for example Coca Cola, and the ceramic industry). Aman Gas, a major distributor of LPG in the capital, estimates that two-thirds of the LPG they sell goes to domestic households, mostly within Khartoum. Similarly, Iran Gas estimates that their LPG sales to domestic households account for twice as much as to bakeries, their second major client. The other main energy consumers in Khartoum – the brick kilns and roadside tea-makers – are not using LPG, despite periodic attempts by the municipality to encourage them to do so.

Energy use in Khartoum is not illustrative for the rest of the country. LPG sales have witnessed a major boost in the early 2000s and led to a significant decrease in the use of wood fuel in the city. According to two major gas distributors – Nile Petroleum Company (NPC) and Iran Gas – 60 to 65% of their total LPG sales are now in the Khartoum area. Figures from the Ministry of Energy and Mining confirm this trend: Khartoum officially accounted for 70% of Sudan's total LPG consumption in 2002. Other urban areas in Central Sudan are gradually moving in the same direction.

The surge in demand for LPG in Khartoum took place between 2000/01 and 2006/07 as Sudan's

oil production increased and with the inauguration of Khartoum's Al Jalli Refinery. In 2001 the government introduced a 50% price subsidy for domestic LPG usage and also exempted domestic LPG appliances from import duties. At the same time, increasing firewood prices accelerated the substitution.

According to NPC, Sudan's LPG consumption accounted for 60,000 metric tons (Mt) in 2000; by 2006 this figure had increased to more than threefold to 220,000 Mt, much of which due to demand from within Khartoum. The gas distribution companies report that demand has since stabilised since VAT on LPG has been reintroduced. According to Aman Gas, demand is now growing at a rate of approximately 10% per annum. Firewood and charcoal traders in Khartoum confirm this shift from woodfuel to LPG usage. Their market share of the energy trade has been steadily declining over the last decade.

LPG Supply

In the 1970s, Agip and Total were the main suppliers of LPG. When oil was discovered in Sudan from the 1990s onwards, new companies entered the market, including NPC (in which the Sudanese government is the majority shareholder, taking over Total's position), Abbarci, Aman Gas, Iran Gas, Bee Petroleum, GapCo (which took over Agip's business) and Sudagas. Abbarci and Aman Gas today are two of the main suppliers for LPG in Sudan. In terms of production, the Al Jalli refinery is the main source of LPG supply.

Over the past ten years, the LPG distribution network expanded significantly, parallel to greater domestic LPG production and increasing demand in Khartoum (and some other urban areas). The total number of LPG agents in Khartoum rose from some 250 in 2000 to 1,300 in 2009.⁶ Also, LPG agents report declining profit margins, a clear indication of the fact that LPG has become a more competitive market. Marketing

5) Second National Energy Assessment of the Ministry of Energy and Mining (2001). See Hood (2009).

6) Data provided by the Secretary General of the Gas Agents Union

strategies therefore play a key role in the LPG supply business. The gas companies, for example, provide incentives to commercial enterprises to switch to LPG, usually by freely installing a tank⁷ in return for a procurement contract with that company. While the availability of LPG has become more and more reliable over the last ten years, it remains a major issue for potential customers to make the decision to switch to LPG.

Today's distribution network is still heavily concentrated in urban areas in central Sudan, and access to LPG supply is much less reliable in most remote towns and rural areas.

Even though supply of LPG within Khartoum has become increasingly reliable many stakeholders interviewed for this study expect major shortages in the future.⁸ As demand for LPG continues to rise and domestic supply is not keeping pace, the government plans to expand the capacity of the Al Jailya Refinery from producing 100 Mt of LPG per day to 200 Mt. This, however, might take up to three years to achieve.⁹

Related to this shortage of supply, there are two electricity-generating stations built some years ago next to the Al Jailya Refinery which use LPG as their main source of energy. In order to fuel these stations, the government effectively takes LPG away from the domestic market. Independent of these policies, LPG supply is increasingly outpaced by demand.

LPG Demand

In the last ten years there has been a widespread shift to LPG by domestic households and by bakeries in Khartoum – traditionally two of the main consumers of charcoal and firewood – supported by the economic benefits associated with the transition from woodfuel to LPG.¹⁰ Approximately 70% of households in the main urban areas, and three-quarters of traditional bakeries have shifted to LPG

7) The provided tanks vary in size depending on the client, from 0.5 to 2 Mt for bakeries, and 20 to 40 Mt for industrial enterprises e.g. a 40 Mt tank was installed for Coca Cola.

8) Reportedly Sudan produced a LPG surplus between 2001 and 2005. At that time, LPG exports were common. When demand increased, exports stopped. At the time of writing, LPG is only imported when Al Jailya refinery closes for renovation.

9) Interviews with UNEP staff, 2010.

10) Costs of cooking or baking with LPG are half (or less) of the monthly costs of cooking or baking with charcoal and firewood.

(in peripheral areas the percentage of households using LPG is lower, but may still be around 50%.

These percentages are higher than in most other towns in Sudan, but indicate the potential for switching from firewood to LPG elsewhere in the country if the LPG distribution network were stronger and transport costs lower. Some LPG distributors expect that LPG demand from Khartoum bakeries will continue to grow in the future. Even if the substantial subsidy on LPG (of around 50%) were to be lifted by Sudan's government, it would still be marginally cheaper to use LPG instead of woodfuel in Khartoum.

Today, the brick kilns in and around Khartoum are the major consumers of firewood (although there is some evidence that this is an industry in decline). This sector seems an interesting entry point for potential scale-up for LPG use in Khartoum: however, it is not (yet) clear how to best use LPG technology for brick-making – best practices and dissemination thereof are lacking.

Also, it is crucial for brick kiln owners that current supply-side constraints on LPG are taken away to guarantee a reliable LPG supply. Tea-makers also make for a significant share of charcoal demand, and therefore could be considered another potential market for LPG scale-up. Data collected for this study indicates that there may be sufficient interest amongst tea-makers to make the shift from charcoal to LPG, but not under current conditions. A major bottleneck for tea-makers to invest in LPG appliances lies in the informal character of their trade.

Although large quantities of firewood and charcoal are still sold in Khartoum, the overall trend in the capital's woodfuel trade in the capital is a declining one. This seems to be influenced as much by the wider policy context as by changing preferences towards cleaner sources of energy. Retail prices of both firewood and charcoal in Khartoum have doubled in the last five to ten years, mainly because of the range of taxes that are applied at state level between the source of supply and the market place in Khartoum.

LPG Governance

At federal level there are a large number of different government departments with an interest in LPG-related policy issues. In addition to the Ministry of

Energy, there is the State Petroleum Administration, Civil Defence, the Ministry of Finance and the FNC which all have an stake in the extent to which LPG replaces woodfuel as a source of energy, pricing levels, and whether LPG imports are permitted in response to rising demand. A preliminary review of federal policy relating to LPG in Northern Sudan indicates that policy choices have not been consistent. There seems to be little movement towards making a stable LPG supply a priority.

State level policies have also had an impact on the use and take-up of LPG, particularly through fees and taxes. Firewood traders in Khartoum for example attribute a large part of the rise in firewood prices to increasing taxes imposed at the state level. This directly affects the economics in favour of LPG. In the absence of a clear policy direction on LPG there are cases of contradictory measures being taken at federal and at state levels. For example, at federal level taxes were removed from domestic appliances to use LPG but some state governments (e.g. the Northern State) have then taken their own initiative in levying taxes on the transport of LPG.

As demand for LPG has started to outstrip supply in Northern Sudan (and Khartoum in particular) this has led to one clear policy decision. The government has prioritised certain users of LPG – households, restaurants and bakeries – over others. This has resulted in limits to policies aimed at further scale-up of LPG, i.e. for vehicles (now banned) and brick kilns (not promoted). Despite these measures, many stakeholders in the LPG industry believe that imports will be necessary to keep pace with rising demand. However, this may not be a popular policy choice with government ministries because of the foreign exchange implications.

When looking at the costs, the Sudan Petroleum Company (SPC) is in charge of the basic pricing levels. SPC determines the price at the refinery gate, applying a subsidy of approximately 50%. For example, in July 2009 the price of LPG in Sudan was \$250 per metric ton compared with the average world price of around US\$530 per metric ton.

The government is also in charge – in theory – of determining the transportation costs from the refinery to the various distribution points around Sudan. In practice, however, there are some significant local differences between LPG distributors. Further research would help to gain a more complete picture of LPG pricing policy and practice in Sudan.

Conclusions

This study has identified three issues that can be identified as key aspects for a potential up-scaling of LPG use in Sudan:

- 1) Analysis of the policy context:** there is a wide range of stakeholders in the Government of National Unity (GoNU) involved in policy-making on LPG (and the choice for energy sources more generally). Government policy is perhaps the most critical factor determining future LPG supply vis-à-vis rising demand (for example through imports or other supply-related measures). Mapping stakeholders, financial possibilities and current policy priorities would help build understanding in the current policy context.
- 2) Capturing lessons on how to promote LPG scale-up:** over the past few decades, there have been a number of projects aimed at increasing the use of LPG, mostly targeted at energy use by domestic households. They have had a mixed record. A workshop to capture the lessons learned and what has worked would be useful to inform any future programming on promoting the uptake of LPG, especially amongst poorer households.
- 3) Developing the technology for brick kilns to use LPG:** although experimentation with LPG in the brick kilns in Khartoum has had limited success, successful experiences in some Nyala brick kilns could provide interesting insights to Khartoum brick kiln owners. This deserves further investigation and follow-up.

In Sudan, microfinance is...?



- A means of poverty alleviation?
- Small loans to informal businesses?
- Social transfers paid by government?
- Different financial services to micro entrepreneurs?
- Directed lending making a loss for banks?
- Income generation activities that NGOs should do?
- All of the above?
- None of the above.....?

Microfinance Supply in General



- Very, very unreliable data from all providers
- Reasonable bank *infrastructure*; *broad range* of products and *lots of funding*
- Demand for Islamic [and conventional] finance much higher than supply
- Current estimate: still far less than 100.000 MF-clients across N.Sudan (Examples: 10/2009: < 7000 Kassala & Gedaref, 03/2010: <4000 Darfur)
- Broad range of products and services
 - But predominance of Murabaha (e.g. 76% in Kassala and 57% in Gedaref)
 - Little familiarity with alternatives (none with MF)
 - Many insurance products
- Formal suppliers and NGOs not well equipped to provide MF services
- Huge debt collection problems (e.g. 27% Gedaref, 14% Kassala)
 - Little risk, no ownership (equity in KRT), no know-how
 - Contract enforcement marred by political interference
- Very limited documentation, and data of questionable quality

Formal Microfinance Supply



- Decentralized authority in bank branches very limited:
 - Large govt-subsidized credit lines for MF ‘implementation’
 - Incentive systems not conducive to innovation, market-orientation
- No demand-orientation/KYC:
 - Statistically calculated allocations from KRT for implementation by the bank branches (see also above)
- No trickle-down of innovations from bank HQs
 - Very little appetite for MF
- Level of technical banking capacity extremely low;
 - Most banks appear un- and ill informed about the poor, MF as a financial service and international standard reporting requirements in general (for banking and MF alike);
 - Most banks in MF partnerships with CBOS lack basic technical capacity to implement microfinance, so limited outreach and high delinquency rates
- Only direct, operational break-even tracked – no ratios
- Almost no adaptation to micro-market (design, collateral, processing)

Microfinance NGO/donor projects



- **Few and small ‘projects’**
 - Donor-determined areas/populations (coverage) – no growth considered
 - Many “Revolving Funds” have not revolved – one off transfers
 - Grants-based contracts, reporting formats and implementation
- **Programme models not set up to be sustainable**
 - Relief/“Service delivery” approach – no commercial orientation
 - Managerial capacity low and transient, non-specialized staff - little training
 - Operational costs not covered (annual top-up)
 - Supply-drive: Pre-set coverage targets – adding adverse risk (UNHCR)
 - Centralized and inefficient decision-making causes delays
 - No appropriate LTS/MIS (expense reporting vs. financial management)
 - Performance targets if exist mostly not appropriate (outreach over quality)
 - No / little leverage of achievements through documentation/linkages
 - No specialized technical service providers on the ground

Distorted Financial Sector



- **Financial services confused with social transfers**
 - Lack of clear definition and delineation of microfinance;
 - Micro-credit used to increase sustainability of social transfers;
 - Micro-credit incorporated in community development and social mobilization interventions without adequate expertise;
 - Non-cost covering price setting encouraged for political ends
- **Credit through government-affiliated structures tend to politicize decisions and discard sound financial management principles**
- **Distortions may prevent sustainable operations and lead to decapitalization and low repayment rates**
- **Successful inclusive finance requires acknowledgement of “3S” approach: Separate; Specialised and Sustainable**
- **Additional funding will not ensure increased A2F, but may damage the market for MF in the longer run.**

SME energy situation in Eastern Sudan



In the urban commercial sector, bakeries (estimated > 90%) and restaurants (est. > 70%) have shifted to LPG.

<- State government legislation prohibits the use of firewood and charcoal in the city center (with very few exceptions for cooking beans and coffee making).

Investment for restaurants and coffee-makers in LPG-use is low.

Investment for bakeries was high, but financed by flour and gas industry joint ventures.

Issues still to be solved:

- No contractual agreement protecting bakeries against gas shortage.
- State government is promoting the shift to LPG, but has no influence regarding LPG policies.
- In the semi-urban and rural areas, bakeries and restaurants are still totally dependent on firewood.

Household energy situation in Eastern Sudan



- Firewood/charcoal is the predominant cooking fuel used by households.
- Biomass fuels might be available locally, but not closer to villages and towns.
- Areas around villages and towns are completely deforested.
- Presently the households use inefficient three-stone fire place and the traditional charcoal metal stove.
- Open fire places (3-stone fire place) generates excessive amounts of particulate matter and Carbon Oxides (CO), polluting the indoor environment, which are harmful to health of women and children, particularly under age of 5 years.
- Presently most poor households resort to the use of agricultural residues, animal dung and almost green shrubs which generate more smoke leading to more health hazards for women and children.

LPG-Promotion via Microfinance The Pilot by Practical Action in Eastern Sudan



Model: households buy a package (cylinder, gas burner, and kiswa plate) using a revolving fund

Package cost: approx. \$58 plus a \$4 down payment for the revolving fund from each member. Training was provided for free.

Since LPG costs less than biomass in urban and peri-urban settings, the households were able to repay the cost of LPG appliances in a period of six to twelve months.

In 2005, an apex association for all supported women's groups was established, the Kassala Women's Development Network (13 branches) to take over the management of the system, offering training (in food processing and business skills) for free, and providing up to 90% of budgeted start-up costs for branch-members' enterprises. Usually, a 2% margin is applied to the budget and the repayment term is 3-6 months.

The repayment discipline is very good, but the system has too little capital and profit-rates to facilitate a sustainable expansion.

Solar Energy-Promotion via MF

The Photovoltaic Guarantee Fund Pilot

by the Ministry of Energy and Mining and UNDP



Model: Households buy solar energy products on credit using a risk-share guarantee fund

Finance-Provider: Social Savings and Development Bank

The repayment discipline was excellent, but the fund was frozen by the Ministry of Energy and Mining at the end of the project period and is since waiting for the permission to start functioning again.

If unfrozen, the fund could be broadened to include LPG and other sources of more sustainable energy.

Open Questions for Discussion



- Do we need to look at LPG only, or also at other more sustainable energy sources?
- What Microfinance Models have the potential provide for sustainable, rapid expansion of LPG-use and other more sustainable energy sources in Sudan?
- What additional support can be provided by the government / by gas suppliers to increase MF for LPG-use and other more sustainable energy sources ?
- What complementary support mechanisms besides MF are needed to increase sustainable energy demand?

Proposed Strategy



1. Policy:

Support development of LPG (& other sustainable energy policies) and appropriate mechanisms for enforcement regarding supply, distribution, logistics and standardization.

2. Awareness & Market Access:

- a) Support to the creation & dissemination of a business directory for sustainable energy-based products services, including LPG
- b) Facilitation of linking Women Development Groups with LPG and other energy suppliers for larger scale collective bargaining.
- c) Provide capacity development support for household LPG & other sustainable energy use
- d) Awareness raising campaign

Proposed Strategy



3. Microfinance:

- a) Advocate for microfinance policies change at federal level
- b) Centre for Inclusive Finance for Eastern Sudan (CIFES): A 'Centre of Excellence' for market-led, demand-driven, responsive and flexible capacity development support to microfinance providers;
- c) Microfinance Risk Share Guarantee Fund for alternative energy-based products and services (based on the experience gained from the UNDP Photovoltaics Guarantee Fund in Sudan) in order to mainstream financing alternative energy consumption (including LPG) into existing Microfinance services provision, including peri-urban, rural & refugee & IDP-communities

4. Mitigation:

Mitigate negative external effects on the Ultra-Poor via alternative livelihoods opportunities support to charcoal / fuelwood making households as well as other climate change adaptation interventions

Forecast for LPG in Sudan (2000-2020): Mohamed Salih Farah (Ministry of Petroleum)

Introduction

Sudan Background

Sudan is a vast country and the largest in the African continent with an area of 2.51 million square kilometres. Geographically, the country lies between latitudes 3° and 23°N and longitudes 21° and 39°E. It has varying rainfall zones ranging from 200 mm and 1500 mm and increasing from North to South.

As the annual rain increases southwards, the vegetation changes from desert through Acacia desert scrub, Acacia woodland and broad-leafed Savannah to tropical rain forest.

Sudan's climate is very hot. Every part of the country experiences average maximum temperatures of over 38°C during several months of the year. Also, Sudan has a tropical continental climate in a narrow fringe along the Red Sea coast and borders

nine countries. Figure 1 overleaf shows the various ecological zones in Sudan.

These geographical, natural characteristics have important implications for Sudan's energy resources. As it covers a vast geographical area with varying climatic conditions, the country is endowed with diverse energy resources such as oil, natural gas, biomass and hydro.

Most importantly, the country's energy potential also includes renewable energy sources (solar, wind and geothermal), which are abundant and well distributed across the country. These could secure Sudan's long term strategic energy supplies.

Sudan Energy Demand Drivers

Drivers of energy demand are demographic, social, as well as economic and environmental. Table 1 lists the main factors pushing energy demand increase in today's Sudan.

The last national census (2008) estimated the total population of Sudan to be around 40 million inhabitants. Securing adequate energy services across vast areas to all of the population is a challenge.

This last census also shows that the urban population represents about 30% of the total population compared to 70% in the rural areas. Urbanization continues to increase and therefore urban energy demand is on the rise. The total population in Khartoum, Sudan's capital accounts for an estimated 15% of the total population.

Rural areas are usually remote and the infrastructure service these areas is inadequate to support the extension of centrally managed services. The energy demand drivers listed above emphasize the need to diversify the country's energy supply mix by:

- Tapping renewable sources;
- Fuel substitution, and
- Improving energy use efficiency in order to secure low-cost energy supply in both urban and rural areas.

Figure 1. Ecological zones in Sudan



Table 1. Main factors affecting energy demand

Category	Factors
1. Macro-economic	Total GDP
	GDP structure by economic sector
2. Demography	Total population
	Distribution of rural / urban / large city
	Total labour force
	Household size (inhabitants / household)
3. Consumption	
3.1 Industry (Agriculture, Construction, Mining and Manufacturing)	Specific energy intensity for each category of end-use. Electricity penetration into heat market.
3.2 Transportation	Volume of freight and passenger transportation
	Distribution of freight and passenger transportation
	Specific energy consumption and load factor of each mode of transport
3.3 Service	Labour force in the sector
	Specific energy consumption by end-use category:
	- Space and water heating;
	- Electric appliances;
	- Air conditioning.
3.4 Households	Type, size and share of dwellings in urban and rural areas:
	- Single family house, apartment, room, villa;
	- Demolition rates;
	- Share of dwellings with hot water facilities;
	- Share of dwellings with air conditioning;
	- Improvement of insulation;
	- Electric appliances

Table 2. GDP Growth Rates 2001 – 2008

Years	2001	2002	2003	2004	2005	2006	2007	2008*
Growth rate in %	10.8	6.003	6.292	5.14	5.647	9.87	8.068	7.764

Source: Central Bureau of Statistics / National Accounts Administration

In doing so, the major challenge is to secure the rising demand for energy due to economic growth, which is continuing at an unprecedented rate in Sudan. The GDP growth rate per annum between 1990 and 1999 increased significantly to more than 6.5% and continued to rise at annual rates ranging between 10.8% and 5.7% until 2008. This was mainly due to the sizeable increase in the share of oil production and metal mining exploration. After oil production started in 1999, Sudan's economy witnessed a major boost to economic development, which in turn led to greater energy needs in the productive sectors.

Table 2 shows the growth rate of the economy during the years 2001 to 2008. Sudan's economic sectors are expected to shift significantly in terms of national GDP share, and the needed energy will also witness a major change (i.e. cooking with

LPG instead of wood fuels) as a result. In order to manage this transition, an adequate energy policy is critical to put national economic development on a sustainable footing.

Economic growth aside, poverty reduction and environmental policies also need to consider future energy demand. Sudan is committed to the Millennium Development Goals (MDGs), signed at the UN Framework Convention on Climate Change in Rio de Janeiro in 1992 (ratified in November 1993) and also ratified the Kyoto Protocol in 2004. Sudan has a low per capita CO₂ emission rate of 0.3 Mt (compared to 13.2 Mt per capita in high-income OECD countries and 4.5 Mt for Arab states).

However, Sudan already suffers from environmental degradation and climate change consequences.

This is due to the fact that most of the people's livelihood is natural resource based, which is highly sensitive to changes in temperature and precipitation. Low and intermittent rain fall leads to reduced crop production, and poor grazing conditions and resulting food insecurity and often to local conflicts.

A national energy agenda therefore needs to balance the interests of economic growth, while at the same time integrate policy objectives regarding poverty reduction and environmental protection.

Energy Consumption Patterns and Trends

Sudan's energy consumption is overwhelmingly dominated by biomass, of which wood and charcoal are the most widely used. Table 3 shows that total energy consumption was 6.6, 8.2 and 9.8 mTOE for the years 1980, 1999 and 2007. Out of this total figure, biomass consumption accounted for 85.2%, 81.7% and 65.3% respectively for the same years. Households are the major consumers of biomass. It is used in traditional and often inefficient forms, mainly for cooking and lighting.

On a positive note, the biomass share in household energy has decreased slightly in terms of the percentage of total energy consumed, from 98.6% of total energy consumption in 1980 to 91.8% in 1999, with that figure unchanged in 2007.

For the years 1980, 1999 and 2007, energy consumers in the agriculture, industry, service, transport and household sectors for accounted for 13%, 16.8% and 31.4% respectively in terms of the consumption of petroleum products. Electric power provided the rest of the energy demand.

The main consumers of petroleum products can be found in the transport sector, representing 66.2, 77.9 and 82.3% of end-use consumption.

Figure 2 shows the energy balance for the year 2009. Renewable energy supply represented by hydro power accounted for only 2% of the total primary energy supplied, while biomass (mainly wood) took the lead providing 62% of primary energy supply. This is followed by petroleum products accounting for 36%. Wood conversion to charcoal shows energy losses of 67% due to traditional and inefficient conversion technologies. The 2009 energy balance also indicates increased oil production of which more than 70% is exported overseas. Only 30% is refined and consumed domestically.

Table 4 on next page shows the national sector-specific biomass consumption and trends during 2000-2009. Household consumption represents 67% of wood consumption both in 2000 and 2009. Households also consumed respectively 80% and 84% of charcoal production during the same years. The data illustrates that the introduction of LPG at the household level has thus far not led to major decreases in wood fuel consumption.

Table 3. Final Energy Consumption by Sector and Fuel type nothing has changed between 1999 and 2007

Sector	Fuel	1980			1999			2007		
		(000) toe	Share %	% From Total	(000) toe	Share %	% From Total	(000) toe	Share %	% From Total
Agriculture	Elect.	6.8	6.7	1.5	2.5	9.8	1.4	10	9.8	1.0
	Oil	94.5	93.3		111.6	90.2		92	90.2	
		101.3	100		114.1	100		102.0	100	
Industry	Elect	20.9	7.8	4.0	28.5	5.2	12.9	52	5.2	10.1
	Oil	151.5	56.8		152.7	22.8		227	22.8	
	Biomass	94.5	35.4		867.8	71.9		715	71.9	
		266.9	100		1049.0	100		994	100	
Service	Elect	9.4	17.8	0.8	36.2	7.2	15.8	103	7.2	14.6
	Biomass	43.5	82.2		1249.0	92.8		1328	92.8	
		52.9	100		1285.2	100		1431	100	
Transport	Oil	570	100	8.6	1066.2	100	13.1	2536	100	25.8
H-Holds	Elect.	22.5	0.4	85.0	58.1	3.4	56.9	164	3.4	48.5
	Oil	54.2	1.0		37.5	4.7		226	4.7	
	Biomass	5536	98.6		4542.0	91.8		4370	91.8	
		5613	100		4637.6	100		4760	100	
Grand Total		6604		100	8152		100	9823		100

Note: The distribution between sectors has not changed between 1999 and 2007

Figure 2. Sudan's Energy Balance (2009)

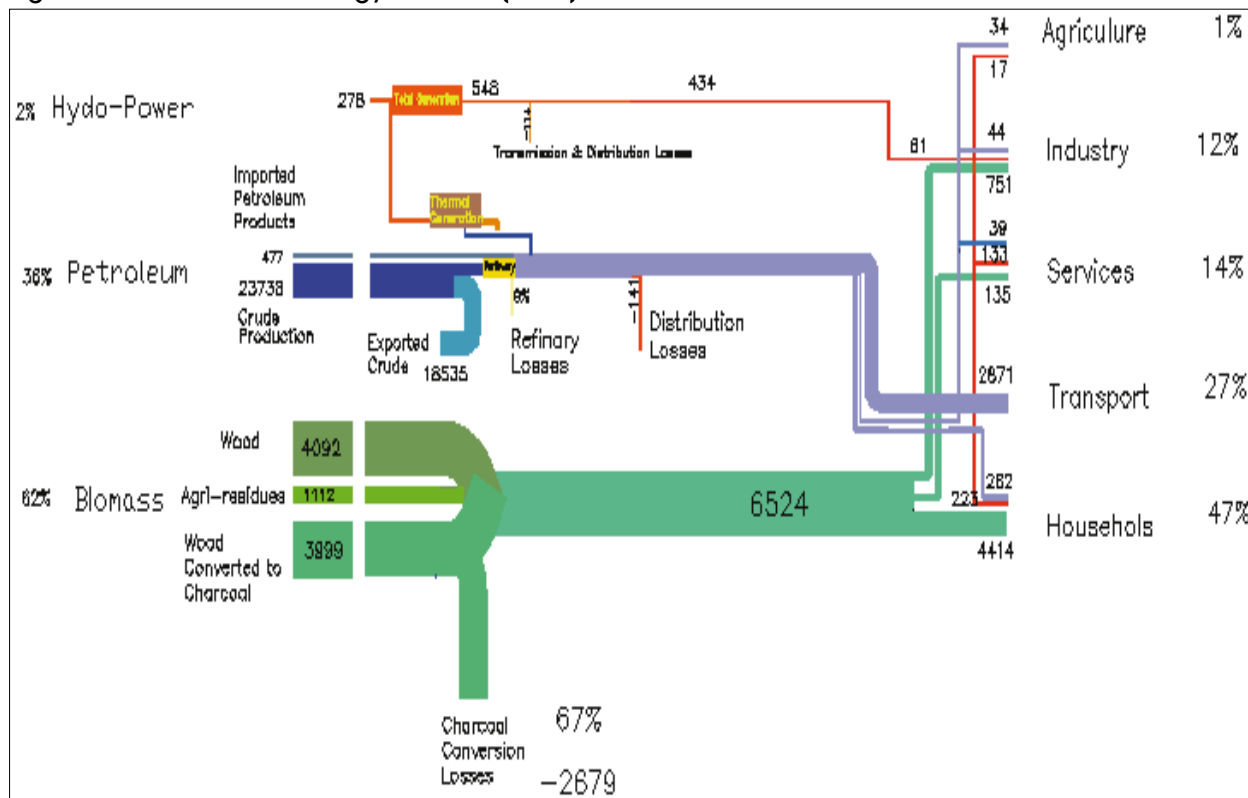

Table 4. Biomass Consumption (kTOEs)

Fuel / Sector	2000	2001	2002	2003	2004	2005	2006	2007	2008	2009
1. Wood	8.96	8.99	9.08	9.15	9.21	9.16	9.30	9.39	9.45	9.96
Manufacturing	1.06	1.05	1.05	1.04	1.02	1.01	0.93	0.94	0.95	1.00
Households	6.00	6.02	6.07	6.13	6.16	6.21	6.28	6.34	6.38	6.72
Services	1.89	1.92	1.97	1.99	2.04	1.94	2.09	2.11	2.13	2.24
2. Charcoal	1.28	1.28	1.28	1.28	1.26	1.26	1.22	1.22	1.22	1.22
Manufacturing	0.07	0.07	0.07	0.07	0.05	0.04	0.00	0.00	0.00	0.00
Households	1.03	1.03	1.03	1.03	1.03	1.03	1.03	1.03	1.03	1.03
Services	0.18	0.18	0.18	0.18	0.18	0.18	0.18	0.18	0.18	0.18
3. Residues	3.85	3.85	4.01	4.03	4.05	4.06	4.10	4.01	3.93	3.87
Manufacturing	1.29	1.28	1.27	1.25	1.24	1.23	1.22	1.21	1.20	1.19
Households	1.81	1.82	1.97	1.97	1.97	1.97	2.14	2.16	2.19	2.21
Services	0.76	0.76	0.78	0.80	0.83	0.85	0.74	0.63	0.55	0.47
Total Biomass	14.09	14.13	14.38	14.46	14.52	14.48	14.61	14.61	14.60	15.05
Residues	3.85	3.85	4.01	4.03	4.05	4.06	4.10	4.01	3.93	3.87
Wood	8.96	8.99	9.08	9.15	9.21	9.16	9.30	9.39	9.45	9.96
Charcoal	1.28	1.28	1.28	1.28	1.26	1.26	1.22	1.22	1.22	1.22

Energy Demand Forecast

In 1999, the Ministry of Energy and Mining (Policies and Energy Planning Dept, formerly known as the General Directorate for Energy Affairs) and the National Electricity Corporation commissioned a comprehensive energy planning study for the year 2030. This was done as a joint effort between the Government of

Sudan and the International Atomic Energy Agency (IAEA). The study was based on the IAEA's so-called 'MAED module' for modelling and analysis in order to determine medium and long-term developments in the country. The Reference Scenario that was developed as part of this study based Sudan's future energy demand on a number of macro-economic assumptions (see table 5 and figure 3).

Table 5. Gross Domestic Product Evolution for the Reference Scenarios, 2005 Constant Prices

Year	GDP (10 ⁹ USD)	Growth Rate (% p.a.)
2005	30.115	–
5015	58.660	6.590
2030	141.307	5.730

Figure 3. Expected GDP development for the Reference Scenario

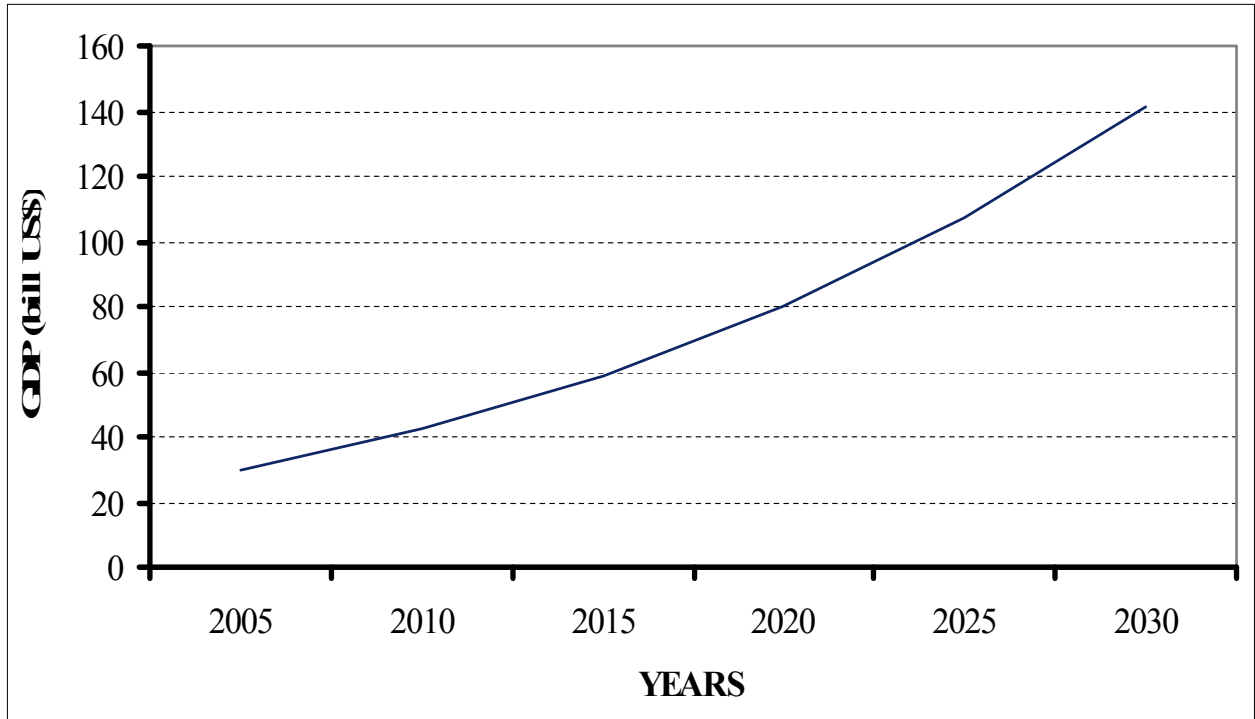

Figure 4. Total Final Energy Demand Growth in the Reference Scenario

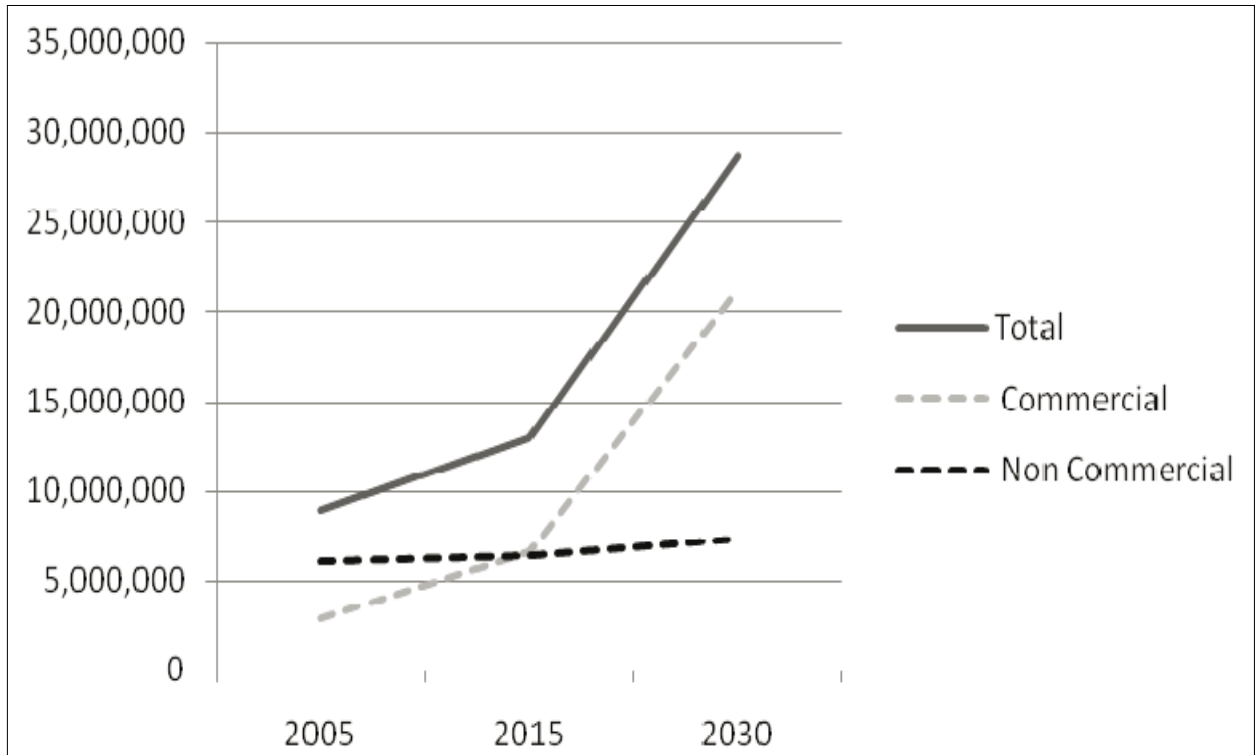
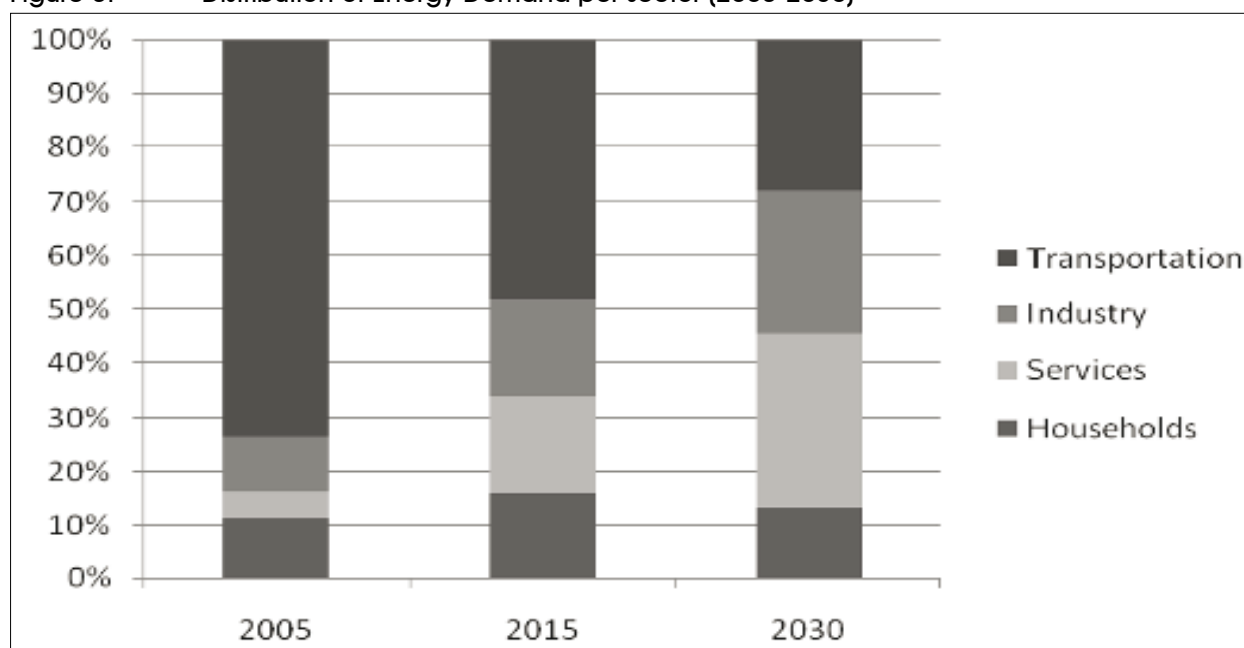

Table 6. Selected data as used for the Reference Scenario

	2005	2015	2030
Population (Million)	35.4	44.5	62.2
GDP/ Cap (US\$/Cap)	850.7	1318.1	2269.7
Population Growth Rate (% p.a.)	2.31	2.31	2.31
GDP/Capita Growth Rate (% p.a.)	2.23	2.23	2.23
Total Final Energy / Capita (TOE)	0.254	0.292	0.460
Commercial Final Energy / Capita (TOE)	0.083	0.149	0.342
Final Energy Growth Rate / Capita (% p.a.)	0.0	1.4	4.65
Commercial Energy Growth Rate / Capita (% p.a.)	0.0	6.03	8.66

Figure 5. Distribution of Energy Demand per sector (2005-2030)



Using the MAED modelling technique, this data resulted in the following set of expected consequences for Sudan's final energy demand in the commercial and non-commercial sectors between 2005 and 2030. Note that this analysis assumes a significant decrease of non-commercial fuel due to increased domestic oil and LPG production.

Figure 4 shows that the total final demand is projected to increase from 8.975 kTOE in 2005 to 28.650 kTOE in 2030. The corresponding demand increases in the commercial sector are up to seven times higher than in 2005.

Table 6 overleaf shows an overview of selected data as it was defined for the Reference Scenario, such as the population and GDP per capita values, related growth rates and the corresponding evolution of final energy growth per capita.

Analysis and Comparison of Sectoral Final Energy Demand

Figure 5 below shows the distribution of commercial final energy demand in 2005, 2015 and 2030 in the Reference Scenario between the industry, transport, household and services sectors.

In 2005, the household and the services sector accounted for only 11.2% and 5.0% of commercial final energy consumption in 2005. This is set to increase to 16.0% and 18.0% in 2015 and to 13.1% and 32.4% in 2030 respectively.

The share of the industry sector will increase from 10.2% in 2005 to about 26.8% by 2030 in this Reference Scenario. The share of the transportation sector will decrease markedly in the Reference Scenario from 73.5% in 2005 to 48.3% in 2015 and to 27.8% in 2030.

Table 7. Total energy demand in kTOE(2000 - 2020)

Years	Petroleum Products	Electricity	Biomass	Total
2000	2569	221	6103	8893
2005	4124	355	6332	10811
2010	22820	1963	7553	32336
2015	34162	2938	7725	44825
2020	47007	4043	7881	58931

Table 8. Biomass demand in kTOE (2000 - 2020)

Years	Residues	Charcoal	Wood	Total
2000	1031	1222	3850	6103
2005	1078	1266	3988	6332
2010	1007	3910	3643	7553
2015	1030	3999	3726	7725
2020	1051	4080	3801	7881

Figure 6. LPG Demand 2000-2020 compared to other petroleum products (kTOE)

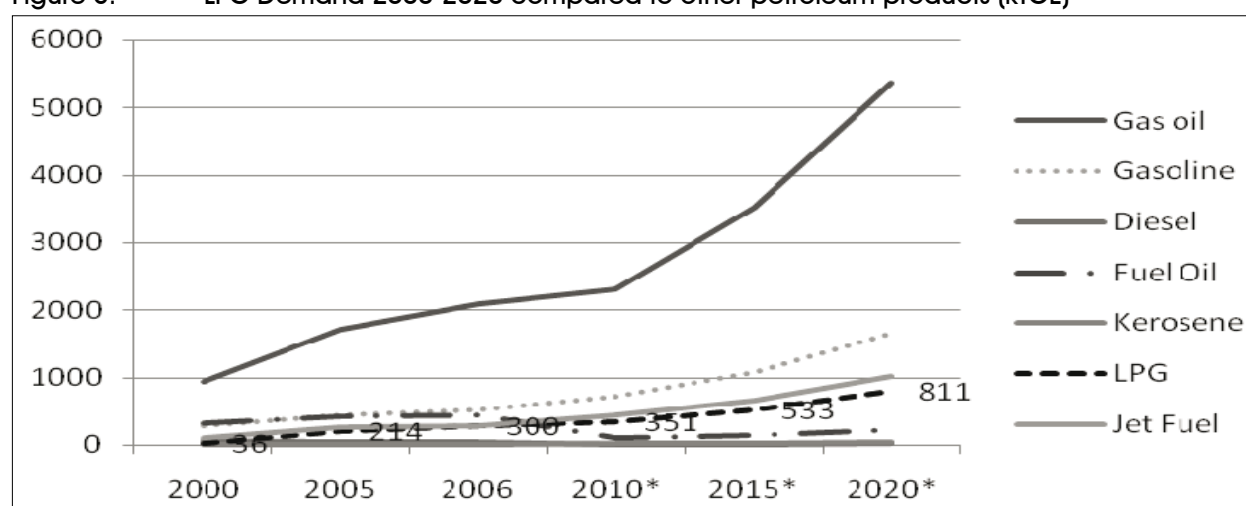

Figure 7. LPG Demand by Sector (kTOE)

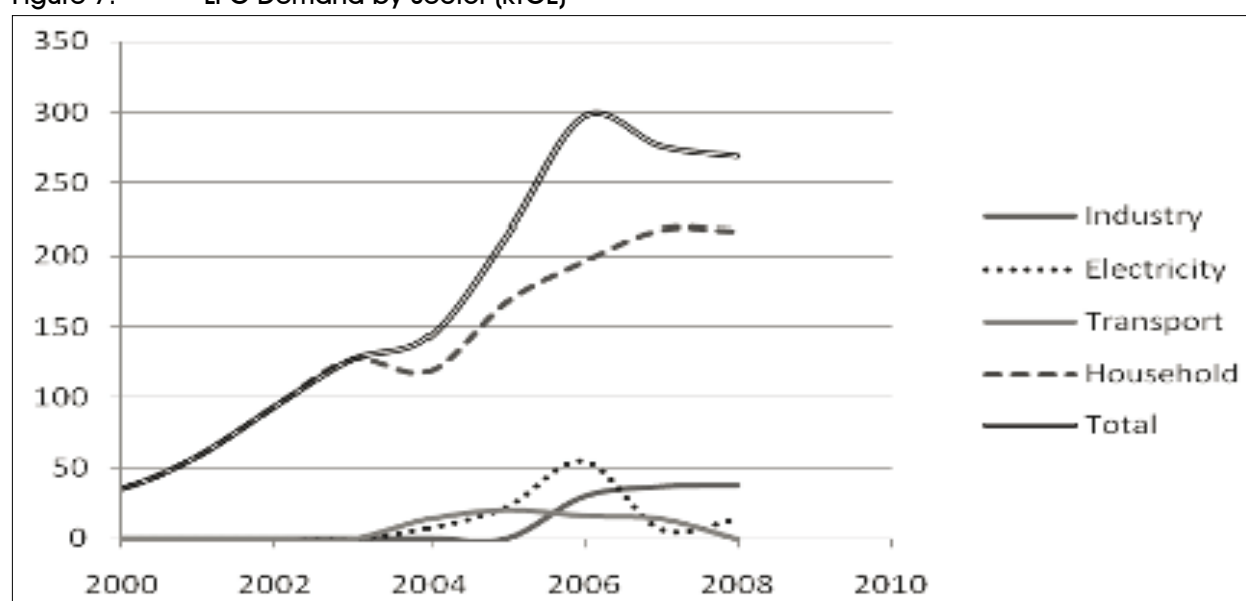

Table 9. Existing and planned refinery capacity in Sudan (000 bbl/day)

Location	Construction	Extension Year	Capacity
Khartoum	2000		50
		2006	Up to 100
El Obeid	1996		10
		2002	Up to 15
		2020	Up to 50
Port Sudan	2013	-	150-175

Figure 8. Domestic Production, Import and Export of LPG (kTOE)

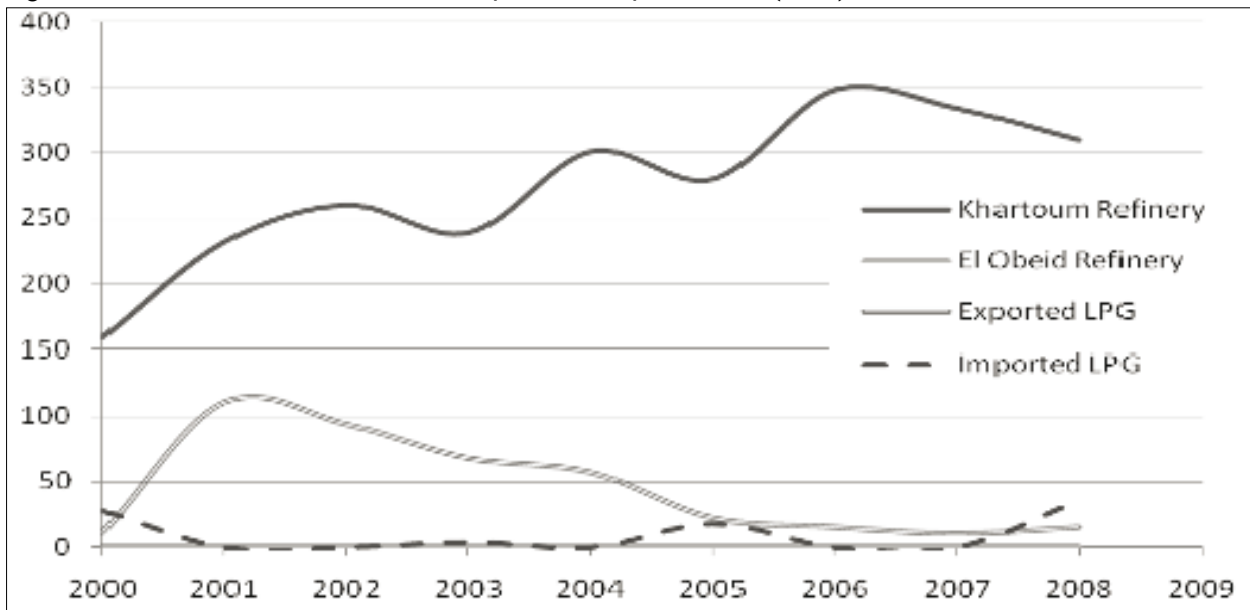
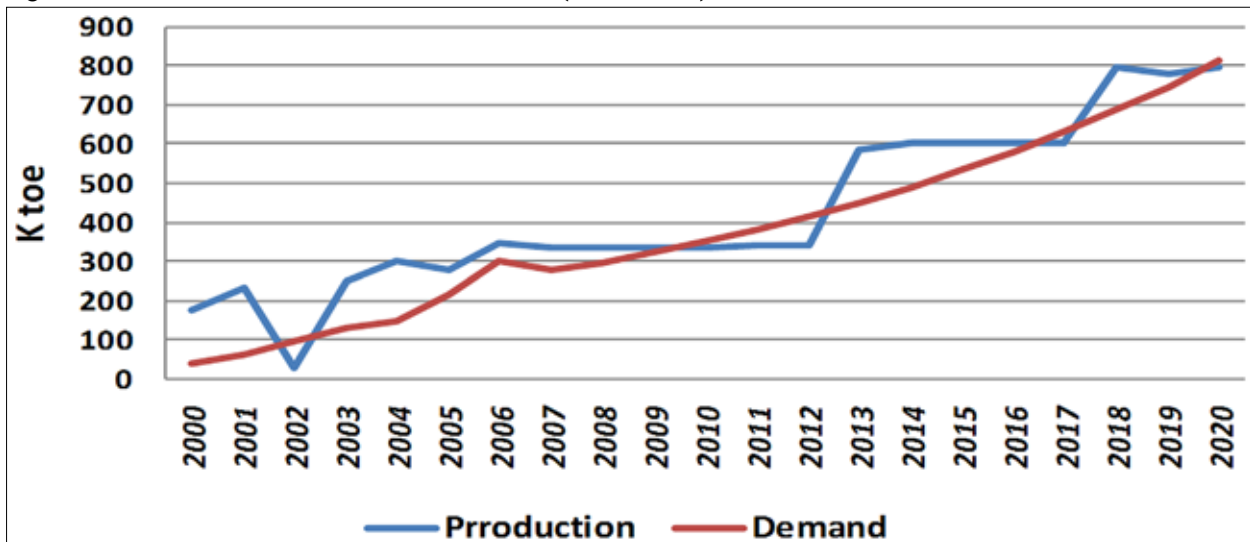

Figure 9. LPG Production and Demand (2000-2020)



Tables 7 and 8 show the details of the expected energy demand by type of fuels in the period 2000-2020.

Figure 6 presents the expected share of energy demand per petroleum product. Figure 7 overleaf provides an overview of LPG demand compared to other petroleum products between 2000 and 2020.

On the supply side, the current production will be insufficient to cover the expected increase in demand. Table 9 gives an overview of Sudan's refinery capacity. Future plans include a scale-up of refinery capacity in Port Sudan in 2013.

Figure 8 reflects the existing situation of domestic production, as well as the import and export figures for LPG. The existing refinery capacities include both Khartoum and El Obeid refineries. Future capacity will depend on the additional refinery capacity in Port Sudan.

Figure 9 brings together LPG demand and supply in Sudan in the period 2000-2020. With the expected additional refinery capacity in Port Sudan from 2013 onwards, the overall supply can offset the increase in demand until the year 2017. By that time, new LPG supplies are needed to satisfy rising demand.

Conclusions and Recommendations

Conclusions

- 1) LPG demand is increasing due to the:
 - Expected increase in overall and urban populations;
 - Expected increase in consumption of LPG in the services sector.
- 2) LPG supply is expected to increase due to the up-scaling of the existing refinery capacity in Sudan.

Recommendations

- Encourage the use of gas and kerosene as an alternative to coal and firewood in order to reduce the residential sector's impact on the environment, along with legislation and policies that support this trend, and the work of education programs where necessary. Promote alternatives to the use of firewood and coal (gas and kerosene) in institutions and residential complexes;
- Rationalize the use of firewood and charcoal using improved stoves programs and do the necessary guidance and programs for the provision and ownership of stoves for families. Conduct a study to compare the current cost of production of different production areas;
- Coordinate with the energy planning institutions in the development of plans for production and supply of fuelwood and by taking into account fuel supplies from other sources;
- Rationalize the use of improved stoves in the domestic and services sectors, and raise the efficiency of combustion in traditional industries (charcoal, bakeries and other industries). Promote the use of solar and other renewable energy (i.e. biogas) for the purposes of thermal cooking of food and water, and heating;
- Amend the *Forest Act of 1989* and develop and activate forest policy in line with local, regional and global environmental policies;
- Work on the replacement of petroleum products (kerosene and gas) instead of firewood and coal in the traditional industries (bakeries, kilns, lime kilns) and improve the efficiency of burning industries; and
- Promote energy efficiency in general across Sudan.

Subsidy on LPG Production: Isam Eldeen Ahmed Kambal; Musa Hamid Mohamed (Ministry of Petroleum)

Introduction

In the past, the nation's overall requirements from petroleum derivatives in Sudan were provided through importing by petroleum marketing companies. After the Arabs-Israel war in October 1973, when the Arab League used the oil as a political leverage, world oil prices quickly quadrupled, the foreign exchange costs for oil imports increased spectacularly, the companies working on the petroleum marketing failed to meet the country's needs because of their limited financial resources. The State had intervened then and a body named the General Directorate for Petroleum was formed as a part of the Ministry of Industry, its main task is to ensure that country's needs from petroleum productions are met while the oil companies working in the country would only sell the petroleum products locally according to prices dictated by the State.

The State continued to provide for country's petroleum product needs through the General Directorate for Petroleum then the General Corporation for Petroleum and finally the Sudanese Petroleum Corporation until the Sudanese oil exploration and production began and El Obeid Oil Refinery went into operation, followed by the Khartoum refinery which started production on May 2000. Since the Ministry of Finance and National Economy had held the ownership of the Sudanese crude oil, an agreement was signed between them and the Ministry of Energy and Mining for supplying the refinery plant with the required crude to meet the domestic demands and export the surplus.

Represented by the Ministry of Finance and National Economy, the State decides on the crude oil price for refinery, and the sale price for domestic consumption, it consequently bears any deficit as a result of the petroleum products sale price being less than its cost price whether this product is locally produced

or imported, it also collects any surplus as a result of a sale which its revenue exceeds its cost.

Deficit in the nationally produced LPG

According to the average price of the Nile blend crude (FOB) Port Sudan in the period of January – October 2010 which was 76.12 USD per barrel; the cost of production and marketing of a LPG metric ton is 2096 SDG while the cost according to the detailed price of the Nile blend crude is 49 USD per barrel. According to the agreement between the Ministry of Finance and National Economy and Ministry of Petroleum the cost of the LPG metric ton is 1564. The subsidy by the State can be seen on the table below.

Based on the table above the subsidy from the state on the LPG for domestic use is 1136 SDG per ton, i.e. 14.20 SDG for each 12.5 kg cylinder; 604 SDG per ton of this (7.55 SDG per cylinder) is a direct subsidy according to the detailed price of the crude, while the remaining 532 SDG per ton (6.65 SDG per cylinder) is an indirect subsidy through the financial backing on the locally refined crude oil, which is sold less than its standard exporting price by 26.12 USD, <36%.

Deficit in the imported LPG

The locally produced LPG does not always cover the country's increasing demands, large amounts recurrently imported to fill in the deficit in the local consumption. Upon calculating the average of LPG imported through Port Sudan in the first half of this year 2010, 785 USD per ton (C&F) Port Sudan, the cost of delivering the product to Khartoum is 2975 SDG. By subtracting the sale's revenue, the imported LPG will have a deficit of 2015 SDG per ton (i.e. 25.19 SDG

Table 1. Oil and LPG prices, LPG revenues and subsidies

Crude oil price in USD	Cost of LPG metric ton in SDG	Revenue on LPG sale in SDG	Subsidy on metric ton	Subsidy on cylinder 25 kg
76.12	2096	960	1136	14.20
49.00	1564	960	604	7.55

per 12.5 kg cylinder) which is direct subsidy from the Ministry of Finance and National Economy deducted from the general budget of the State.

Conclusion

Based on the facts mentioned above, it is concluded that the State sells the LPG for domestic

use with a price which is less than half its cost in the case of the local production, and one third of the imported LPG cost, that means the State's subsidy on the consumed product is more than its sale price for the locally produced LPG and twice its sale price when it is imported, this is to encourage its use placing its significant benefits on environment and economy first.

Increasing pressure on Forest Products – Gap Between Demand and Supply: Abdalla Gaafar Mohammed; Bulgies M. El Hassan Osman; Esmat Hassan Abdalla (Forests National Corporation)

Sudan's natural resources are vast and include water, soil, seven different types of vegetation, and wildlife. The management of these resources and related data collection is divided among a number of agencies, such as the Meteorological Department, Ministry of Irrigation, the Rural and Central Water Corporation, the Ministry of Agriculture, and the Forests National Corporation (FNC) – in turn these institutions fall under the Ministry of Environment, Forestry and Physical Development. Wildlife management is the responsibility of the General Administration of Wildlife, a sub-division within the Ministry of Interior.

Even though natural resources management requires these agencies to work closely together, this is generally not the case. As a consequence, policies often are inconsistent and poorly coordinated, particularly regarding land use issues (agriculture versus forestry). An additional problem lies in the fact that traditional land use (grazing or agriculture) often remains outside the control of governmental agencies.

Today, Sudan faces alarming rates of land degradation, with some 500,000 ha of annual forest lands lost to unsustainable practices. As a response to these concerns, the Comprehensive National Strategy (CNS) (1992-2002) and the Quarter-Century Strategy for Socio-Economic Development (2003 – 2027) stipulate that 25% of the country should be allocated to forestry, range and pasture, and wildlife. It also stresses the importance of environmental assessments and of the role of local communities in the planning process.

However, data remains scarce. Sudan has never had a complete national forest inventory. The state of natural forests can therefore only be extrapolated from a number of ad-hoc surveys, and from existing UN Food and Agricultural Organization (FAO) reports. According to those sources, the forest area in Sudan decreased by nearly 10%, from 76.4 million hectares in 1990 to 69.9 million hectares by the

end of 2009. Until now, reforestation initiatives are limited to the country's forest reserves, which are under public management.

The exploitation of natural resources is nothing new in Sudan. Forest management plans were first developed in 1927 as a response to major forest cover decline. Conservation policies followed in 1932 and 1948, which aimed to introduce sustainable land use across the country. However, these efforts only targeted a small number of forest areas. In general, the history of Sudan is one of massive overexploitation, and has led to serious environmental change, in particular around the savannah regions.

Looking at the demand side, it is no surprise that forest resources are in rapid decline. Major drivers include rapid population growth, wood-based construction techniques, agricultural schemes and overgrazing. Energy consumption is the dominant factor in this equation: in 1996 Sudan consumed energy equal to 5 mTOE, of which 77.8% was in the form of woodfuel (firewood and charcoal). At current exchange rates, this represents an import value of energy consumption of US\$282.8 million.

Also, forest products have to be transported over long distances, as the availability of resources does not relate to the population density. The South has 75% of all forests and 25% of the population, while the North has 25% of forests and 75% of the population. As a result, forest cutting in the North goes well beyond what is set as the adequate cutting quota (particularly in central Sudan and Khartoum). If no action is taken to promote alternatives to woodfuels in the immediate future, Sudan will face an even more serious environmental crisis in the coming years.

In the future, demand for forest products will shift, but will remain a major problem if not addressed now. (Note: these calculations were done in 1994). In the so-called 'Dream' scenario, households in urban areas are expected to decrease their woodfuel

demand by 2.5% each year (50% by 2020). Rural households are expected to have a slower start in switching to non-biofuel energy. Services and industry would not need any woodfuel in this scenario.

The 'Accommodate the Predictable' scenario is more conservative. Households could decrease their consumption by 10% by 2020, and the service and industry sectors would slowly decline further vis-à-vis the 1994 baseline data.

In anticipation of this future demand scenario, the FNC has long since started to undertake various measures to curb the demand on forest products. Past initiatives included a social forestry programme, aimed at enhancing awareness and supporting sustainable forest use in local communities. Energy conservation programmes were also implemented, such as an alternative energy project promoting the use of molass-bagasse blocks and a project facilitating the scale-up of fuel-efficient stoves.

Today, FNC strategies also attempt to increase the level of forest supply in Sudan. This is done through a comprehensive portfolio of activities, including

- 1) The scaling-up the national afforestation programme (from 10,000 to 130,000 feddans);
- 2) Increasing the forest reserve area (from 1.7m ha to 12.6m ha);
- 3) Improving land tenure regulation to encourage farmers to plan sustainable forest use;
- 4) By promoting environmental education at the federal level.

Based on these experiences, the FNC recommends a number of issues to be addressed as part of a future policy:

- 1) Start a national programme for bio-fuel production;

- 2) Request the Ministry of Agriculture to allocate a specific percentage of agricultural land to forestry (estimated as 20% of the future consumption of fuelwood);
- 3) Secure local and international support for afforestation programmes;
- 4) Mobilize the local population to participate in forest protection, reforestation and management processes;
- 5) Promote energy conservation techniques, alternative energy sources and energy-efficient devices;
- 6) Facilitate environmental awareness among decision-makers;
- 7) Find alternatives to current practices that are detrimental to the environment;
- 8) Enhance synergy between different agencies;
- 9) Develop adequate work plans for individual forest reserves;
- 10) Define tasks and responsibilities between local, state and federal levels;
- 11) Encourage private sector involvement;
- 12) Support research programmes in forestry and conservation;
- 13) Work on capacity-building for forest resource management;
- 14) Scale-up activities aimed at disseminating fuel-efficient stoves;
- 15) Increase governmental budgets on forestry;
- 16) Synchronise forestry programmes with other development programmes such as poverty reduction efforts; and
- 17) Align forest policy with investment strategies.

The process of woodfuel substitution for LPG in the Sahel – a study of nine countries: Paul Kerkhof (UNEP Consultant)

Introduction

This presentation is based on an exhaustive external evaluation of household energy initiatives in the so-called CILSS countries – or *Comité permanent inter-État de lutte contre la sécheresse au Sahel* – which comprise nine countries ranging from Chad to the Cap Verde archipelago in the Atlantic Ocean.

This evaluation was carried out from May to September 2010 for the European Union and the CILSS headquarters. A database of some 3,000 documents originating from the nine countries was the starting point of the analysis, which was followed up by an in-depth analysis through interviews lasting one week in each of the countries.

Throughout the region, woodfuel substitution for LPG is a key issue in the household energy sub-sector. However, the situation varies between the various countries, with some of them having adopted pro-LPG policies quite some time ago, while others are more recently engaged, or not yet ready for it.

This paper draws on the regional experience and proposes a number of issues which may be of interest to the LPG conference in Khartoum.

The study results show that the nine countries can be classified according to the woodfuel/LPG dynamics phase. Clearly, all of them are different in some ways, yet similarities can be drawn out.

Figure 1. Study area - the Sahel to the west of Sudan



For practical purposes, three different categories will be presented here:

- 1) The early innovators
- 2) Countries which are at present engaged in pro LPG measures, and
- 3) Countries which have chosen not to engage in pro-LPG policies as yet.

Some issues can be identified which might be of interest to different situations in Sudan.

Senegal and Cape Verde: the early innovators

Senegal and Cape Verde are similar in terms of economic development, being well-off compared to the other Sahelian countries and, in those terms, being similar to Sudan. Senegal and Cape Verde are also similar in household energy terms, having had an active LPG support policy which has boosted woodfuel substitution over the last 10-15 years from 60,000t in 1995 to 140,000t in 2005 in the case of Senegal.

The share of LPG in the household energy budget is now much greater than most other countries in this study. Dakar is a major city comparable to Khartoum, where LPG now constitutes about 90% of the overall cooking fuel budget (though charcoal is still the principal fuel in all other urban areas).

In Cape Verde, LPG is the major cooking fuel for all urban areas. Direct LPG subsidies were the major regulatory tool in both countries.

Both countries depend entirely on import for fossil fuel consumption. The steep price hike around 2005 seriously burdened the government budget so that subsidies were gradually phased out. This has not resulted in a reversal of household fuel consumption patterns. The LPG consumers in Dakar, and those of urban Cape Verde, mostly held onto their new habits in spite of much higher LPG prices.

However, the trend of increasing woodfuel substitution for LPG has been interrupted, and the sales volume has become static. This is particularly problematic in the long-term for Senegal, which has a significant population increase (2.1%), but less so for Cape Verde (0.5%).

Figure 2. Distribution of the woodfuel resource in relation to Dakar

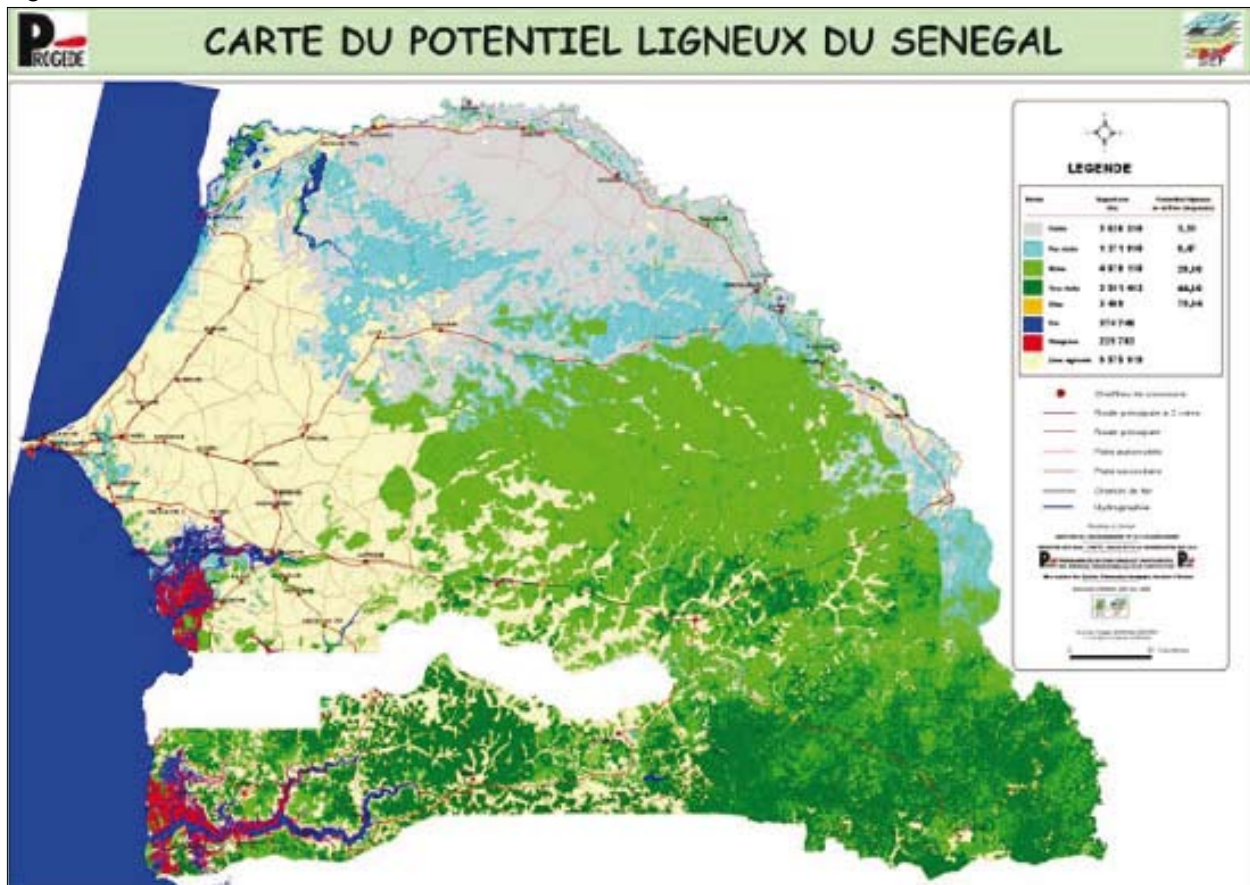
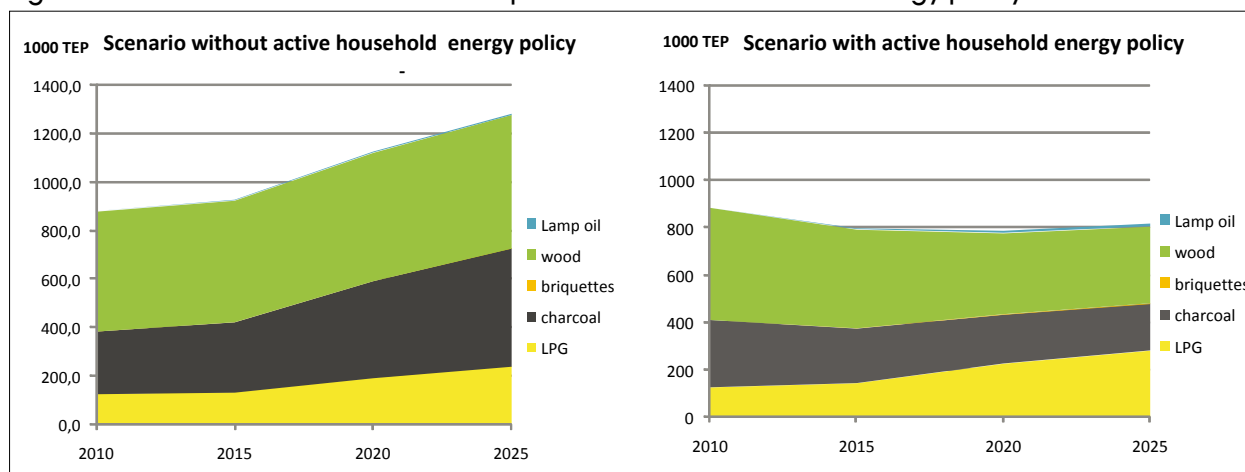

Figure 3. Wood versus LPG consumption and active household energy policy



On the other hand, Senegal has significant surplus wood-fuel resources, which Cape Verde does not have.

The map on the preceding page illustrates the distribution of the woodfuel resource in relation to Dakar (in the centre, at the Atlantic Ocean). It shows the South and east of Senegal are still well endowed in woodfuel resources, but a sustainable long-term energy balance depends on a cohesive energy policy.

The potential time bomb in the household energy balance is Senegal’s demographic growth. Without an active household energy policy, woodfuel consumption will increase more or less exponentially. Senegal’s population will grow by more than 50% over the next 15 years.

The graph in figure 3 above, (left) shows how woodfuel consumption will increase in the absence of an active household energy policy, in spite of an increase in LPG consumption from 2010 to 2025. An active energy policy (graph on right) will contribute to increased LPG consumption (from about 200,000t to 320,000t/yr), but only up to a point: direct LPG subsidies are hardly feasible.

The biggest effort to be undertaken is clearly in the area of energy economy: improved stove efficiency, improved charcoal production efficiency, to a lesser extent the use of waste such as charcoal dust and agricultural residues (briquettes, etc.).

Similarly in Cape Verde, woodfuel consumption in urban areas, which is very low at present, will

Figure 4. Wood versus LPG consumption and active energy policy in Senegal

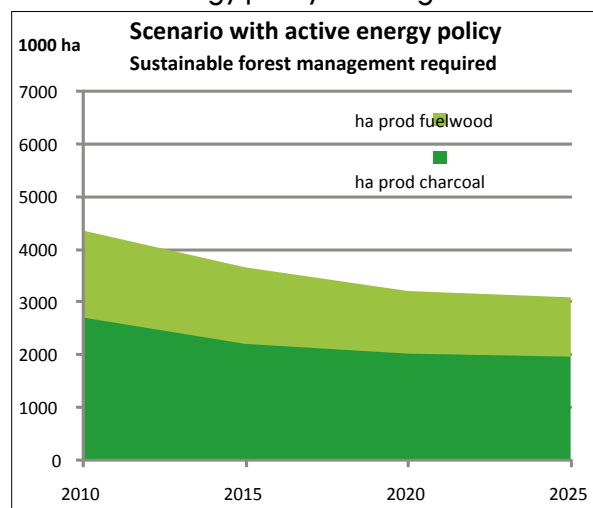

increase steeply unless energy economy policies are deployed in general, and energy efficient stove promotion in particular.

In the case of Senegal, the graph in figure 4, above, demonstrates the effects anticipated from an active policy in terms of the pressure on the forest resource: instead of a steeply rising demand for sustainable woodfuel production areas, the need for such areas will actually decrease if an active household energy policy is pursued.

Natural resources will thus be available for other environmental and economic needs (pasture, agriculture, biodiversity, etc.).

The case of Chad, Niger, Burkina Faso and Mali

Apart from Senegal, the region has four other major countries in population terms, all of which are characterised by low GNP per capita figures in comparison to Senegal and Cape Verde. They have variable, but still considerable, resources in the southern perimeter where the major urban areas are situated.

All of them are seriously concerned about the sustainability of the woodfuel resources feeding the major urban centres, and have engaged in pro-LPG measures over the past five years or so, including direct subsidies. We will look at the case of Burkina Faso as an example of this group of countries.

Burkina Faso still has some considerable forest resources in the southern half of the country, but it is the most densely populated of the four countries.

Since the early 1990s, it has set aside forests as fuelwood resources managed by local communities, yet supervised by small teams of technicians paid from overheads on fuelwood sales to urban areas.

Officially, charcoal has been banned much of the time. This system has proved to be economically and environmentally sustainable, but is slow to put in place.

Much of the country's forest resources are not covered by the scheme and degradation is widespread, especially due to clearing for agricultural expansion. For this reason, an alternative household energy policy has been developed, revolving around substitution.

LPG has been promoted in various ways, in particular though:

- Direct subsidies paid principally from special 'LPG levies' on diesel and gas;
- (Micro) credit to new users, especially to reduce initial cost to new LPG consumers;
- Publicity campaigns.

The LPG consumption has increased from around 2,000 tons annually to about 17,500 tons per year at present. In the case of Mali, a level of 20,000 tons has been reached, while Tchad and Niger are at about 3,000t/yr at present, but showing a strong increase.

In Burkina Faso and Mali, the more significant levels of subsidised LPG consumption have begun to hurt the national budget. In the case of Mali, the backlog of subsidy payments by government to distributors has led distributors to temporarily stop LPG distribution. In both Burkina and Mali, interruptions in LPG supplies (except for larger, unsubsidised bottles) has led to fierce public reactions.

The example of the 'early innovators' (Senegal and Cape Verde) as well as Burkina and Mali show that direct subsidies may work as an initial incentive, but will soon become a victim of its own success. Chad and Niger are hoping to avoid the trap by becoming fossil fuel producers themselves. Chad will start to produce LPG in 2011 and hopes to produce 36,000t/yr – but negotiations with the Chinese operator have not yet been concluded.

Neighbouring north Nigeria and others may want to buy LPG and have more purchasing power than local Chadian consumers. This highlights the problem that LPG subsidies support the better-off, contrary to poverty reduction objectives. In any case, 36,000t/yr of LPG would be a major relief for

Figure 5. Forest resources in Burkina Faso

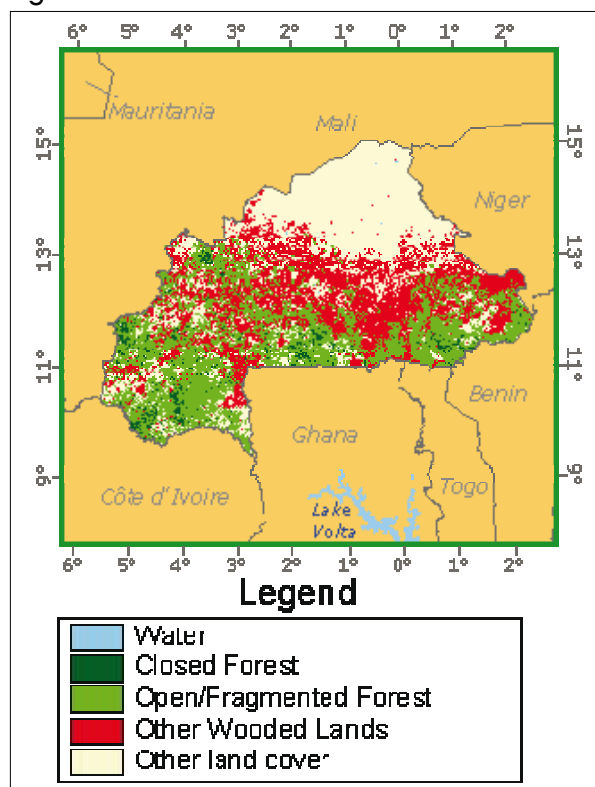
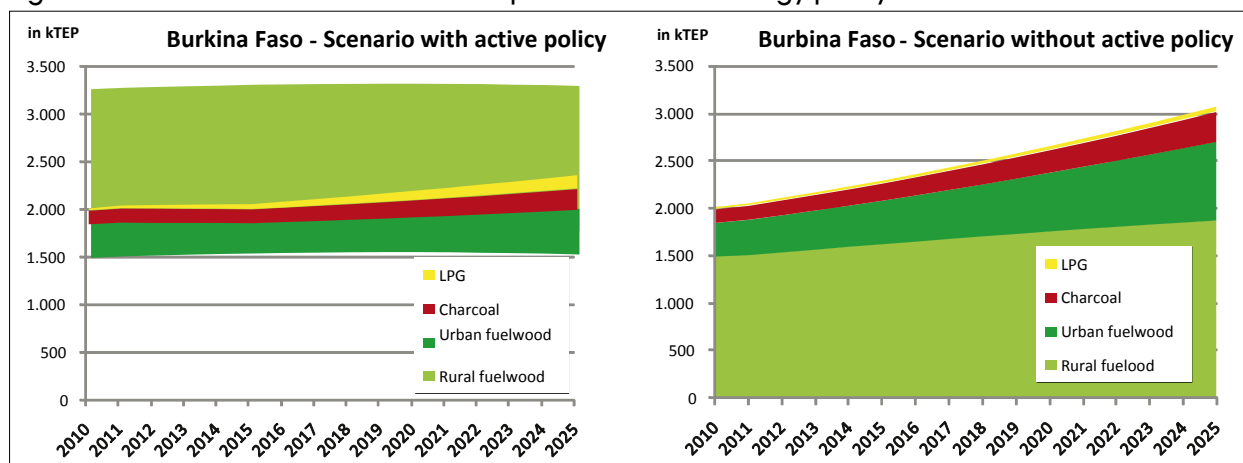

Figure 6. Wood versus LPG consumption and active energy policy in Burkina Faso



N'Djamena at present, but not in the longer term, and in any case, not at all for the country at large. The country's population increase alone would quickly absorb that amount of LPG.

In countries such as Burkina and Mali, but probably also Chad and Niger (if the volume of effectively locally available LPG is disappointing), an active, broad household energy policy is clearly needed. While LPG plays an increasingly important role in major urban areas, the national energy balance is at present so reliant on woodfuel, that energy economy measures should be at the heart of the regulatory mechanism.

This is illustrated for Burkina Faso in the two graphs in figure 6 above.

It is not much different for the other three countries. Massive demographic growth over the next 15 years in all four countries make it unlikely that LPG can take the lion's share of household energy supply, unless major sources are found and made available to local consumers at lower than international market rates. This is an unlikely scenario. Energy economy should probably be the major pillar for a successful energy policy.

The case of Guinea Bissau and Gambia

The Gambia, and in particular Guinea Bissau, are situated in areas well endowed with woodfuel resources, somewhat comparable to forested parts of South Sudan. The share of LPG so far is minor

and governments have not actively intervened to increase its role.

Guinea Bissau is by far the poorest of all CILSS countries but clearly the richest in woodfuel terms. The energy policy includes priorities other than woodfuel development (such as electrification).

The case of The Gambia is somewhat different: the tourism industry and numerous expatriates are among the key LPG consumers – direct LPG subsidies would benefit them, which can hardly be the objective of a national energy policy in a poor country.

Nevertheless, these countries may run into a woodfuel deficit because of rapidly expanding populations and due to cross-border woodfuel commerce.

Given the wasteful use of woodfuel at present, more economic use of this resource should be a major element of a new household energy policy.

Cross-cutting issues

In order to highlight some key issues arising from the country studies, the following tables have been drawn up. They should be helpful to clarify the transition between wood, charcoal and LPG, and the role of energy economy measures within reach of Sahelian actors.

The first table reminds us that in terms of mass, the energy value of charcoal is twice as high as air-dried fuelwood, and that of LPG is three times as high.

Table 1. Energy values for different household energies

	Calorific value in GJ/ton	Equivalent in tons air dried fuelwood
Fuelwood	15	1
Charcoal	29	1,93
LPG	46	3,07
1 TEP	41,8	2,79

Table 2. Conversion figures for LPG-woodfuel substitution in the west African Sahel

	Overall	LPG cooker	3-stone fire	normal stove	improved stove
LPG	1 kg LPG = 46 MJ	→ 46*45% = 20,7 MJ effective			
↓	1 kg of LPG replaces :				
Fuelwood			20,7/12%= 172,5 MJ > 11.5kg wood	103,5 MJ= 6.9kg wood	69 MJ= 4.6kg wood
Charcoal				3.6kg charcoal	59,1 MJ= 2.04kg charcoal
Charcoal consumption expressed in wood equivalent :					
Traditional kiln	Efficiency 16%			22.5kg wood	12.8kg wood
Improved kiln (*)	Efficiency 25%			14.4kg wood	9.6kg wood

(*) In west Africa, the Casamance kiln provides a standard for improved kilns

Table 2 shows that LPG replaces fuelwood by 4.6 to 22.5 kg of wood per kilogram of LPG, depending on the type of fuelwood, type of charcoal production and the type of cooking stove used.

This picture is further complicated by the fact that the physical distance between producer and consumer modifies conversion rates. Great distances reduce net energy efficiency of fuelwood use and of the overall energy economy, while this applies to a much lesser extent to LPG (1/3). Charcoal (1/2) is situated in between these two fuels. It helps explain why fuelwood is, and is likely to remain, the major fuel type for rural consumers but not for urban users.

We can then estimate the amount of forest, in terms of fuelwood production, replaced by LPG. In the southern Sahel (e.g. south of Nyala) the average annual sustainable fuelwood production would be up to 1 ton per hectare.

In the typical wasteful charcoal scenario (traditional kiln, wasteful stoves), one hectare of sustainable wood production is equivalent to 45kg of LPG. On the opposite end of the scale, (fuelwood produced from nearby sources, used in improved stoves) 217

kg of LPG would be needed to replace one hectare of sustainable fuelwood production.

We can then proceed with an economic evaluation, comparing the cost of putting in place a sustainable LPG commodity chain with a sustainable woodfuel commodity chain. The results will be different from area to area, depending on the variables.

Finally, the West African experience demonstrates that new energy technologies begin to play a role and should be envisaged in long-term energy scenarios.

Biodiesel begins to play a role in Burkina Faso, and Mali intends to follow suit.

The new generation cellulose-based biodiesel is expected to be developed by about 2020, and may have a significant impact on traditional household energy patterns.

New energies must therefore be considered in an energy scenario and related policy development. The CO₂ balance is another issue of increasing importance in the medium- and long-term, justifying or undermining certain policy options. Energy policy development is thus a major challenge.

Review of Previous LPG Disseminations Initiatives – The Gabat Gas Project

**Osama Tagelsir Gasim Elsaid,
Forests National Corporation**

Fuelwood consumption is a major source of deforestation in Sudan. Firewood and charcoal accounted for 80% of the energy consumed in households in the Sudan by 1994, when the country consumed energy equal to seven million tons of oil equivalent (TOE), petroleum products. (hydropower accounted for 1.5% and 3% respectively).

In 1994, the national survey on demand for forest products indicated that the 16 states of Northern Sudan consumed 13.8 million cubic metres (m³) of round wood equivalent of firewood and charcoal in 1994. The table below shows the m³ round wood equivalent for wood fuel (charcoal and firewood) as consumed by all sectors of the economy of the Sudan in 1994.

In the coming years, these pressures on the Sudanese forest resources are expected to increase further. Uncontrolled land clearing for agriculture, grazing, bush burning and fuelwood gathering have become a great threat to the environment and hinder sustainable forest management. As a consequence, non timber forest products such as gum Arabic have become more problematic. In order to combat environmental degradation and deforestation, there is an urgent need to enhance the national capacity for forest and environmental management strategies.

Over the years, the Forests National Corporation (FNC) has initiated various projects targeting the energy sector, in a bid to support sustainable forest management and community-based natural

resource management. One such initiative is the Gabat Gas Project.

The Gabat Gas Project

The project aimed to reduce energy consumption from biomass by 50% within a period of 3-5 years. It encouraged the use of LPG gas as a substitute for charcoal and firewood, first in the household sector, and then in the industrial and service sectors. This was done by:

- 1) Awareness campaigns to inform the public about environmental risks resulting from reliance on biomass as a source of energy and the advantages and benefits of using LPG in homes;
- 2) Coordinating with state agencies to reduce gas prices and the prices of its own consumption;
- 3) Forcing distribution companies to supply gas cylinders to citizens at low prices and smooth instalments to be attractive to the workers and local communities;
- 4) Facilitating companies willing to participate in FNC activities around this project; and
- 5) Distributing LPG through the FNC office network.

Major Challenges in the Implementation

The FNC consulted a number of companies (NPC, Apresee, Aman Gas, Iran Gas, etc.) with the request to adopt this project. In turn, companies wanted the FNC to provide financial guarantees and did not agree with a devaluation of the cylinders and LPG accessories.

Table 1. Sudan 1994 fuel consumption, m³ round wood equivalent

Sector	Charcoal	Firewood*	Total	%
Household	6,070,208	6m148,379	12,218,587	88 %
Industry	11,673	1,050,174	1,061,847	8 %
Commercial and Services	283,899	10,736	294,635	2%
Quran Schools	0	209,044	209,044	2%
Total	6,365,780	7,418,333	13,784,113	100%
National per capita	0.30 m3	0.35 m3	0.64 m3	

These efforts coincided with the arrival of the investor from Amarat (the owner of the company Sodagaz Alamarty), where he was introduced to the FNC by the General Manager of the Sudan Railways, who had agreed to support the Gabat Gas Project through supplying the project with 12.5kg cylinders and accessories (stove, regulator and hose).

The price was set at 80 SDG, to be paid in four instalments for state employees or individuals, and six instalments for the agents hired as proxy distributors. The first contract, signed with the company on 7 February 2001, provided for a system to deal with cash sales to agents and sales with instalments to individuals.

However, this method was unacceptable to the gas agents who argued that all other gas companies dealt with them through instalments (12-15 instalments). This was solved by an agreement between the company and FNC to set up a system that allowed instalments for dealers.

As part of the project, the FNC received a total of 88 521 gas cylinders as detailed in the table below.

The main reasons for households not to switch to LPG were:

- The initial cost of gas appliances is high;
- There is a safety problem with regard to the cylinders' adapters; and
- The refilling network is not well developed.

Table 2. Gas cylinders received by FNC

No.	State	Used Cylinders
1	Blue Nile	3.100
2	Red Sea	4.700
3	Sennar	4.900
4	Nile River	13.200
5	Gedarif	13.739
6	South Darfur	1.650
7	White Nile	3.150
8	Gazira	1.800
9	Northern	3.050
10	Kassala	3.600
11	North Darfur	1.000
12	West Darfur	1.000
13	South Kordofan	3.000
14	North Kordofan	6.345
15	West Kordofan	1.387
16	Khartoum	22.900
Total		88.521

Lessons Learned from the Gabat Gas Project

- 1) Stakeholder participation:** The Ministry of Oil should share these policies with stakeholders. Stakeholders have participated in the sugar debate, the mineral debate and in the water debate. Why not in the energy debate?
- 2) Poor institutional arrangements:** The present institutional arrangements are not adequate to facilitate the sustainable development of biomass energy. The information for planning and policy formulation, and for human resources and institutional capacity, were inadequate.
- 3) Environmental benefits:** If biomass energy is used efficiently, then our woodlands and forests will not be under threat. Carbon sinks will not be destroyed.
- 4) Biomass Energy Technologies:** Biomass energy technologies available in Sudan include improved household stoves, improved institutional stoves, efficient charcoal-making kilns and efficient bakeries. We should pay attention to new biomass energy technologies and give it more prominence and more funding.

Where is our attention?

Our current energy policy pays more attention to petroleum and electricity than to any other sources of energy because these two are seen as energy sources that will drive the country to industrialization.

Who should control biomass?

Most of our biomass energy comes from forests and woodlands in the form of wood or charcoal. *The Forests and Renewable Natural Resources Act 2002* acknowledges that "forests are the main source of domestic fuelwood for the Sudan people".

Supporting policy

In order to scale-up LPG services, the government should subsidize the purchase and refilling of the cylinders, increase the number of instalments and intensify the scale-up of the distribution network.

LPG policy should include:

- increasing the LPG production;
- improving the supply chain;
- supporting public education on safe use and handling of LPG, and
- facilitating the domestic manufacturing of LPG infrastructure and accessories.

