

INTERNATIONAL MARITIME  
ORGANIZATION



UNITED NATIONS  
ENVIRONMENT PROGRAMME



MISSION REPORT

of the IMO/UNEP Consultant to the  
First MEMAC Task Team Meeting  
Bahrain, 25-29 June 1983

The present Report is submitted under the sole responsibility of the Consultant, and does not commit the United Nations or IMO, which do not necessarily endorse the opinions set forth.

INTERNATIONAL MARITIME  
ORGANIZATION



UNITED NATIONS  
ENVIRONMENT PROGRAMME



MISSION REPORT

of the IMO/UNEP Consultant to the  
First MEMAC Task Team Meeting  
Bahrain, 25-29 June 1983



The present Report is submitted under the sole responsibility of the Consultant, and does not commit the United Nations or IMO, which do not necessarily endorse the opinions set forth.

## CONTENTS

	<u>Pages</u>
Report	1
Annex A	7
Annex B	9
Annex C	11
Attachment I: Final report on the First MEMAC Task Team meeting, Bahrain 25-29 June 1983 (with 5 annexes and 2 attachments)	
Attachment II: Technical Information Papers Nos 1 - 5.	

## INTRODUCTION

Discussions by telephone related to a possible requirement for a consultant to attend the First MEMAC Task Team Meeting took place between Dr. Wonham of IMO, Mr. Elder of UNEP and Captain Garnett of ITOPF\* over the period 17-20 June. Since the requirement was not entirely clear, with the agreement of Dr. Wonham, Captain Garnett telephoned Mr. Khalid Fakhro, Director of MEMAC, on the morning of 20th June. The outcome of this conversation was reported to all parties concerned in the Federation's telex dated 20th June 1983, (Annex A). After a further exchange of telexes and telephone calls the invitation for Capt. Garnett to attend this meeting was finally confirmed in Mr. Fakhro's telex of 27th June, (Annex A).

Both Mr. J.A. Nichols and Capt. M.J. Garnett had visited the Gulf area in April and at the request of various authorities and oil companies had provided advice as to the response requirements related to the Nowruz spill. In addition, Mr. Nichols had completed a theoretical evaluation of the threat (Annex B), this had been sent to various officials in the countries concerned. Although not agreed by all the recipients it is considered that this evaluation is indicative of the probable situation facing the countries in the Gulf. This latter view was supported by a letter from Dr. Cormack who had been an IMO Consultant at a previous MEMAC Technical Meeting. In the view of the Federation it is certainly the most worthwhile piece of work we have seen relating to the threat and reports from the area would appear to confirm the resultant evaluation is of the right order.

The views of this Federation on both surveillance and response over and on the sea are succinctly explained in Technical Information Papers Nos. 1-5 ( Attachment II ). Since the very start of this incident the Federation had been continuously invited to give advice and assistance to various authorities in the area and elsewhere. Similar advice has been give on all occasions and is as follows:

1. The threat generated by this spill could not be accurately evaluated without over flying the source and following the slick as it moves down wind and water to its limit.

---

\* International Tanker Owners Pollution Federation



2. It is expected that most of slick would disperse and dissipate in the first 100 miles leaving a limited amount of tar balls and small rafts of viscous oil on the surface.
3. Since these patches would most likely be widely spread over the surface of the Gulf, unless they were concentrated naturally their containment and collection would be inpracticable if not virtually impossible.
4. Containment and collection would only be worth trying in the immediate vicinity of the source. In addition on such occasions collection and containment is virtually impossible at night and, except in constant and light wind conditions, extremely difficult during daylight. The expected success rate could be as low as 5% of the oil spilt.
5. Dispersant treatment of the slick at source could prove a practical and effective means to increase the rate of natural dispersion.
6. Since such response close to the source was presently not possible, the only sensible steps to take were to concentrate all efforts on defending those facilities most at risk and with the highest priority for defence. Such a response would be based on deflecting oil away from such facilities with collection being the second priority. It is expected that most of the oil would have to be recovered from the foreshore.

## MISSION ACTIVITIES

On arrival in Bahrain on Tuesday 28th June the consultant met Mr. Khalid Fakhro and was immediately asked to attend the MEMAC Task Team Meeting.

### Sub-committee on Surveillance

The consultant was initially invited to join the sub-committee examining the proposed surveillance plan under the very able leadership of Mr. Khalid Fakhro. They had already gone a long way to arriving at a final plan for the actual surveillance, the details of this plan are shown in Annex 3 of the Final Report attached.\* The area to be covered by surveillance is detailed in paragraph 2 of this Annex, being divided along the Geneva Line into two sections. Surveillance in the eastern section is to be implemented by the Iranian authorities and in the western section by the Saudi authorities. The committee had previously agreed that surveillance of this designated zone, adjacent to the war zone was the best option available to them. When requested by the chairman of the sub-committee to give his views the consultant recommended the following:

1. Surveillance of this area, in excess of 4,500 sq miles should be carried out by a fixed-wing aircraft using visual observation. They should fly at between 1,000 and 1,500 feet at about 120 miles per hour. He was immediately informed by the group that fixed-wing reconnaissance was not acceptable to the Iranian authorities and it had been agreed that all surveillance was to be carried out by helicopter.
2. Accepting this, that more than one helicopter should be employed to carry out the surveillance to ensure it was both continuous and effective. It was pointed out that there were difficulties in carrying out surveillance of such a large area resulting from the limitations of helicopter endurance and speed. These limitations are compounded by the relatively small swath width of any aircraft flying at the height required to see patches of weathered oil on the surface, many of them being very small. The optimum height

---

\* Attachment I to this report



would be in the region of 1500' giving a swath width of 5 miles as a maximum. That you cannot see oil up-sun is another limiting factor.

3. That surveillance should be visual and that SLR should not be fitted since it would not be sufficiently effective to be worthwhile. In addition the consultant added his personal doubts as to the viability of SLR if the oil patches were widely spread over the sea, particularly as a proportion of them might be just under the surface.

#### Sub-committee on Combating

The consultant was then invited to join the sub-committee studying combating, very ably led by Mr. Naizar Tawfiq. Shortly thereafter a proposed plan was tabled by one of the members (see Annex C). This paper was discussed at very considerable length there being a divergence of views amongst members. Sufficient to say that it did not meet with universal approval and alternative proposals were put forward and discussed. Some hours later the consultant was asked to draft a new paper pulling together the stated views of the members for further consideration by the sub-committee. This was completed shortly after midnight and accepted as a basis for further discussion. At 1.30 the meeting was closed for the night. The consultant included amendments and additions in a redraft. The plan was typed and presented to the sub-committee at the opening of their morning meeting and in the main is as written in Annex 2 of the Final Report attached.

The discussions ranged widely but invariably returned to one of two topics:-

1. To evaluate and decide upon the most likely amount of oil present and entering the designated area.
2. The best method of combating (providing required response) to the oil present.

Although many related topics were discussed in some detail, it was these two points that proved most difficult to get a unanimous view.

Undoubtedly the excellent presentation given by the representatives of the Mexican Government of the problems and a number of the tried solutions at the Ixtoc Well spill were of considerable assistance to the group. That recovery of oil very close to the source of the spill had cost the Mexican authorities some 60 dollars/barrel concentrated the mind wonderfully well.

It was finally agreed that some 25 tonnes of oil would, in all probability, enter the area daily. In addition that by the time the oil got there it would consist of a heavily weathered tarry material and be spread over a wide front. As can be seen in Annex 2 of the Final Report, it was considered most likely that in such conditions a shingle ship system would probably collect as little as 2-3 barrels/day and it follows at very considerable expense. The need for positive helicopter control throughout the operation was agreed and it was appreciated that this alone would greatly increase the cost of the operation.

In addition the members agreed that by the time the oil reached the designated zone, being a heavily weathered tarry material, it would be extremely difficult to pump. The combination of uncertainty as to whether there would be a sufficient concentration of oil to collect, the inherent difficulties in successfully concentrating, collecting and pumping such material together with the extortionate cost of such an operation caused the members of the group very considerable concern. As can be seen in the recommendations in Annex 2 of the Final Report, it was finally decided that the optimum plan of action was to carry out a limited trial as detailed.

The aims of the trial are two-fold, firstly to satisfy the team that a single ship system would be effective in concentrating oil under the conditions prevailing in the designated zone. Secondly that a pumping system could be made available which would pump any oil that was concentrated into a temporary storage tank.



The consultant was thoroughly involved in all these deliberations and his advice was requested on a number of occasions.

During the group's discussions the Saudi Arabian delegate had reported that they had successfully concentrated oil using a single ship recovery system (Hydrovac Sweeping Arm) but had been unable to recover the oil itself using the associated pump. Bearing this in mind the consultant recommended that trials should be carried out using two different types of single ship systems, both of which were available in Saudi Arabia. One trial would use the Hydrovac Sweeping Arm as before but combined with a Terling screw pump GT185 which is available in Bahrain, the second trial would use one of the new Spring Sweep systems which are now available in Jubail. The main advantage being that the associated pump works on the vacuum principle. Between them these two trials would substantiate whether the oil could be pumped using any equipment that was available presently in the Gulf area.

Undoubtedly if neither system proved effective it was the view of the consultant that there was little else worth trying. It was appreciated that if successful in collecting oil, the vacuum system would also collect a considerable quantity of water which would increase the requirement for temporary storage. It was further recommended that should either system prove effective the material recovered should be pumped into a container with a large opening at the top and not pumped into the ship's tanks from where it would be impossible to shift it.

#### Action Team, financial and other requirements for surveillance

The consultant was not greatly involved in the preparations of that part of the Report covering financial, personnel and material requirements at the MEMAC Headquarters. He stated his view that it would be impossible to recruit the right sort of man at the salary offered unless the recruiting could be done through IMO. In addition that should a 'marine man' be recruited as the coordinator then the operations man should be an 'offshore man' and visa versa.



28877A UNEP CH  
887514 TOYLOP G

ATTN DR WONHAM

C.C. MR KHALID FAKHRO  
C.C. MR KESKES, MR ELDER - FOR INFORMATION

AS AGREED HAVE TALKED WITH KHALID FAKHRO, DIRECTOR OF MEMAC  
IN SAHRAIN. WE DISCUSSED THE FOLLOWING:

THAT THE FUNDAMENTAL REQUIREMENT IS FOR AN IN-DEPTH AND  
KNOWLEDGEABLE EVALUATION OF THE TECHNICAL PROBLEMS RESULTING  
FROM THE NOWRUZ FIELD SPILL, AS FOLLOWS:

1. PRESENT PROBLEMS
2. PROBLEMS UNTIL WORK ON WELLS COMMENCED
3. NEW PROBLEMS GENERATED DURING THE CAPPING AND DRILLING OPERATIONS

ON COMPLETION OF THIS EVALUATION A SERIES OF ALTERNATIVE RESPONSE  
ARRANGEMENTS COULD BE EXAMINED AND AN ESTIMATE OF THE CHANCES OF  
SUCCESS OF EACH ALTERNATIVE GIVEN. I HAVE RECOMMENDED HE PUTS  
THIS FORWARD AS THE BEST APPROACH AND THAT IT IS CARRIED OUT BY  
A SMALL WORKING GROUP (ONE PERSON FROM EACH MEMBER STATE MOST  
VERSED IN OIL SPILL RESPONSE WORK) WHO WOULD REPORT TO THE MEMAC  
COMMITTEE. AS I UNDERSTAND IT HE WILL RECOMMEND THIS TO THE  
COMMITTEE ON SATURDAY OR SUNDAY OF THIS WEEK WITH THE VIEW TO  
THE WORKING PARTY MEETING ON MONDAY SHOULD THE GROUP AGREE.

MY TELEPHONE NUMBER ON SATURDAY AND SUNDAY IS AS FOLLOWS:  
(3647) 3102 AND IF IT BE ACCEPTED THAT WE SHOULD PARTICIPATE TO  
GIVE ADVICE AND ASSISTANCE THEN I WILL GO TO SAHRAIN IMMEDIATELY.

FOR INFORMATION, OUR VIEW ON FUNDING IS THAT THIS FIRST VISIT  
(NO MORE THAN SEVEN DAYS) SHOULD BE CARRIED OUT ON IMO RATES TO  
INCLUDE FULL HOTEL AND AIR TRAVEL. SHOULD WE THEN BE REQUIRED  
TO CARRY OUT FURTHER ADVISORY WORK WE WOULD ASK FOR 225 POUNDS  
A DAY, OUR NORMAL FEE.

BEST REGARDS

MIKE GARNETT

20.6.83

28877A UNEP CH  
887514 TOYLOP G

837514 TOYLOP G

- 8 -

ANNEX A

890 MEMAC BN

REF:ME  
837514 TOYLOP G

9990 MEMAC BN

REF:MEM-223

27.6.83

ATTN: CAPT MIKE GARNETT

FROM: KHALID FAKHRO  
DIRECTOR OF MEMAC, BAHRAIN.

VERY URGENT  
-----

TASK TEAM WORKING ON DETAILED CONTINGENCY PLAN WLD FINISH THIS PLAN BY TUESDAY EVENING , IT WLD BE ADVANTAGEOUS TO HAVE YOU TUESDAY EVENING IF POSSIBLE TO REVIEW THE PLAN WITH TASK T TEAM ON WEDNESDAY MORNING.

PLANNING TO HAVE GENERAL DISCUSSION WITH THE MEXICAN GROUP PASSING BY ON THURSDAY WHICH YR PARTICIPATION WLD BE APPREC. TO DISCUSS GENERAL GUIDELINES IN COMBATTING SPILL AND MANAGEMENT OF A TASK TEAM.

PLEASE ADVISE FLIGHT DETAILS .  
HOTEL ACCOMODATION CAN BE ARRANGED AT SHERATON AT 80.22.500 PER DAY FOR SINGLE ROOM IF REQUESTED.  
YR RESPONSE BY RETURN WITH FLIGHT DETAILS MUCH APPRECIATED.

MANY THANKS,

WITH BEST REGARDS:  
KHALID FAKHRO,  
DIRECTOR OF MEMAC,  
BAHRAIN.

:.C ELDER, UNEP, 29877.

987514 TOYLOP G  
9990 MEMAC BN

THE FATE OF NOWRUZ CRUDE

Assumptions

1. Oil spreads to a limiting thickness of approximately 0.1 mm beyond which it will disperse as a first order process with a half-life of about 12 hours.
2. The maximum size of droplet produced by a breaking wave has a diameter equal to the thickness of the slick.
3. If the droplets have a diameter of 0.1 mm (produced from a slick of thickness 0.1 mm) or less, they will not rise to the surface.
4. If the first order dispersion process is complete after 6 half-lives, the total time for dissipation of the slick is given by the equation:

$$t_d = t_c + 6t_{1/2}$$

where  $t_c$  = time to spread to a thickness of 0.1 mm

5. The viscosity, pour point and surface tension of Nowruz crude are such that spreading will obey Fay's model viz.

$$L = K \left( \frac{\sigma^2 t^3}{\rho^2 \nu} \right)^{1/4}$$

- $\sigma$  = spreading coefficient of oil
- $t$  = time
- $\rho$  = density of water
- $\nu$  = kinematic viscosity of water
- $K = 10$  in the wind direction
- $K = 1$  across the wind

TABLE 1

COMPARISON OF PHYSICAL PROPERTIES OF NOWRUZ CRUDE AND OTHER CRUDES

<u>Crude Characteristics</u>	Nowruz	Ekofisk	Kuwait
Specific gravity	0.9296	0.847	0.870
Gravity °API	21	35.6	31.1
Viscosity cs. @ 50°C	138	4.25	7.6
Pour point °C	-19	-12	-20
Wax content	2.4	6.5	5.5

Composition yield

Fractions	% wt.		
5-100°C		5.5	7.0
100-160		7.0	11.1
160-250		12.5	15.1
250-350		7.2	19.0
over 350		67.8	47.8
			54.2

- Note: 1. Properties of Nowruz residue boiling above 350°C are as follows:  
 Spec. grav.= 0.997; Pour point = -14°C; Viscosity at 50°C = 4,125 cs.
2. Hasbah crude: Specific gravity = 0.995; Pour point = 33°C



Calculation of life times of slicks

In the case of a continuous supply of oil from a blowing well, the dispersion of the slick is given by:

$$-\frac{dN}{dt} = 0.693 \frac{N}{t_{1/2}}$$

$t_{1/2}$  = half-life in hours

N = amount of oil remaining on the sea at time t.

Eventually an equilibrium quantity of oil on the sea is reached at which point the rate of discharge equals the rate of dispersion. Table 2 shows the equilibrium amounts for different discharge rates.

TABLE 2

Rate of oil discharge		Time to reach critical thickness (0.1 mm) hours	Equilibrium amount of oil remaining on sea (tonnes)	Total time* for complete dissipation of oil after wells capped (hours)	Amount of oil remaining after 6 half-lives if not totally dissipated (tonnes)
bbls/day	tons/hr				
2000	10	2	173	74	4
7000	35	3½	606	75½	10
14000	70	5	1212	77	20

\* Assuming process complete after 6 half-lives

Whilst the half-life concept implies that complete dissipation of oil cannot occur, observations made during the Ekofisk blow-out in the North Sea indicated that Ekofisk crude was totally removed from the sea surface within 6 half-lives (72 hours). Nowruz oil is somewhat more viscous than Ekofisk crude and contains a higher proportion of residue boiling above 350°C. However, the elevated temperature of the Gulf and the higher specific gravity of Nowruz crude may compensate for these other properties.

Although the ultimate fate of Nowruz oil can only be established by direct observation, the above considerations suggest that the threat of serious pollution to coastlines of the Gulf is small.

If the oil dissipates totally after 6 half-lives, the maximum distance which can be reached from the source (assuming extreme case of 0.5 knot current and 35 knot wind acting in the same direction) is about 115 miles (in broad agreement with Iranian observations). This would limit shore pollution to coastlines north of 28°N.

If, on the other hand, the oil does not dissipate completely after 6 half-lives, the remaining residue would be produced at a rate of between 4 tonnes per day and 30 tonnes/day depending on the oil discharge rate.

J.A. NICHOLS  
18.5.83

POLLUTION COMBATTING PLANS

I. INTRODUCTION

It is the intention of this plan to proceed in combatting the pollution resulting from the Nawruz Field and any other sources observed by the surveillance team within the identified area. This plan is based on the available type of oil observed (tar balls and mats) in the Gulf sea area. since the incident occurred.

Since quite a lot of information is missing to reach a more comprehensive plan, we considered some theoretical assumption in order to achieve a practical combatting procedure, and it is the role of the Task Team, who is going to implement this plan, to modify this procedure accordingly.

Since the combatting equipment depends largely on the oil characteristics, therefore a limited number of equipment has been considered, which satisfy any type of pollution incidents, other equipment that may be required during the implementation can be added.

II. OIL SPILL RECOVERY

In order to recover the oil from the sea area, two alternative cases are recommended to be implemented :

i) CASE ONE :

- 1- Hire two to four tugs with the crew (cost detail in attachment I)
- 2- Hire hopper barges or pontoon (cost detail in attachment I)



- 3- Hire supply boat (cost detail in attachment I)
- 4- Hire two cranes (one on board the barge or pontoon and other on land)
- 5- Hire land trucks (No. and cost in attachment I)
- 6- Purchase deep sea oil boom ( cost in attachment II)
- 7- Purchase nets (No. and cost in attachment II)
- 8- Purchase or hire sweeping arm.

ii) CASE TWO (ALTERNATIVE) :

Hire self propelled split hopper barges design to sail in exposed area. The barge comprises of two halves and can be longitudinally. Helipad, UHF marine band, HF radio and radar (Decca) are additional equipment on board. The barge is 72.90 M long, 13.20 M wide with a 5.65 M depth.

Speed loaded	10 knots
Loading Capacity	2750 tons
Hopper capacity	1250 Cu. M.

This vessel is capable to remain at sea for a period of two months in any weather conditions and the crew is as follows:

- 1. Captain
- 1. Chief Engineer
- 1. Mate
- 2. Engineers
- 2. Deck Hands
- 1. Cook

The cost of this barge is US \$ 3750/day, excluding fuel and water supply and also excluding the modification required for oil combatting.

The idea to use this barge for surveillance and oil combatting is that both can be done at the same time. Small helicopter will go along with this barge to cover wide area and lead the combatting action.

iii) Disposal - Land

Activities involved with the disposal of the collected oil comprises of storage and transportation, treatment (recycling if possible) and ditching or burning.

Equipment required for this are:

iv) PERSONNEL

In spite of the availability of sailors with the hired equipment, it is always necessary to have extra well experienced personnel to take-over and supervise the operation.

It has been estimated that 8-12 persons should be available for the Task Team for each group in operation (each group consists of two tugs, one barge) to handle the oil boom installment, skimmer operation if any, and installing and removing nets.

ATTACHMENT I

TUGS SPECIFICATION

- 33 M long 8.5 M wide
- 32 Poland Pull
- Normal free navigation 12 M
- Cabin for four persons
- Cost US \$ 350 - 400/ hr.
- Cost/day with 4 persons

BARGES

- 1) Flat Barge (from ASRY)  
97 x 27 M  
10,000 DWT.  
Cost: US \$ 1750/day (for period of three months)
  
- 2) Hopper Barge (Yoco Marine)
  - a) 1500 DWT. Self-propelled  
US \$ 1300/day  
Fuel and water not included
  - b) Flat barge with crane US \$ 1400/day

SUPPLY BOAT

US \$ 2200/day  
Fuel and water not included

The total cost required for the marine equipment is as follows:

<u>US \$/day</u>	<u>Equipment</u>
19,200	2 Tugs
2,200	1 Supply boat
2,600	2 Hopper barges
1,400	1 Flat barge with crane
25,400	5% fuel and
1,270	water supply
<hr/>	
<u>26,670</u>	Total cost for Marine equipment only.

ATTACHMENT II

- 1) Landing Trucks US \$ 100/day
- 2) Oil Boom US \$ 400/month  
(2000 M) US \$ 280,000
- 3) Nets

INTERNATIONAL MARITIME  
ORGANIZATION



UNITED NATIONS  
ENVIRONMENT PROGRAMME



Attachment I

to

MISSION REPORT

of the IMO/UNEP Consultant to the  
First MEMAC Task Team Meeting  
Bahrain, 25-29 June 1983

FINAL REPORT ON THE FIRST MEMAC TASK  
TEAM MEETING, BAHRAIN 25 - 29 JUNE 1983

The present Report is submitted under the sole responsibility of the Consultant, and does not commit the United Nations or IMO, which do not necessarily endorse the opinions set forth.



INTERNATIONAL MARITIME  
ORGANIZATION



UNITED NATIONS  
ENVIRONMENT PROGRAMME



Attachment I

to

MISSION REPORT

of the IMO/UNEP Consultant to the  
First MEMAC Task Team Meeting  
Bahrain, 25-29 June 1983

FINAL REPORT ON THE FIRST MEMAC TASK  
TEAM MEETING, BAHRAIN 25 - 29 JUNE 1983

The present Report is submitted under the sole responsibility of the Consultant, and does not commit the United Nations or IMO, which do not necessarily endorse the opinions set forth.

In the Name of GOD the Compassionate, the Merciful



## *Marine Emergency Mutual Aid Centre*

REGIONAL ORGANIZATION FOR THE PROTECTION OF THE MARINE ENVIRONMENT

Nawruz Oil Spill Incident  
First MEMAC TASK TEAM MEETING  
25th - 29th June - Bahrain.

FINAL REPORT

1. Introduction

On 7-8 May, 1983 the Third Meeting of the Technical Committee held in Bahrain under the auspices of MEMAC. The outcome of the meeting was a Plan of Action which called for commencing oil pollution surveillance and cleaning operations in a designated area south of the declared war zone. In order to implement this plan the first Task Team of ROPME Regional experts met in Bahrain 25 - 30 June, 1983, to discuss details of the plan. The Task Team meeting was attended by experts from Bahrain, Iran, Iraq, Oman Qatar, Saudi Arabia, U.A.E. ROPME professionals, Director of MEMAC and invited international experts (Annex 1).

2. Opening of the Meeting

Mr. Khalid Fakhro, Director of MEMAC opened the meeting at 11.30 on 25 June, 1983, and welcomed the participants on behalf of MEMAC and Ropme. After explaining the objectives of the meeting he suggested that one of the delegates chair the meeting. Consequently, Dr. Nizar Tawfiq of Saudi Arabia was selected as Chairman of the meeting.

Before proceeding with the Provisional Agenda, Mr. Fakhro informed the meeting that Mr. C. Van der Burgt, Chief Engineer - Director of the North Sea Directorate of the Netherland Ministry of Transport and Public Works (Rijkswaterstaat) was available to make a brief presentation on the Dutch proposal for an integrated air surveillance system.

Mr. Van der Burgt informed the meeting that his Government was offering ROPME or any other Member state interested, an air surveillance twin engine aircraft equipped with SLAR and IR/UV instruments capable of detecting marine oil pollution. The Dutch Government is prepared to provide the aircraft for two weeks free of charge providing operational expenses and crew accommodation are borne by the user. If the aircraft proves to be successful further arrangements for continued air surveillance and oil pollution combat can be set up.

The meeting was also briefed by Mr. Abdul Latif Al-Zaidan, co-ordinator and Director of Programme, about the offer of SOMID Company.

As this offer was not clear, Mr. Al-Zaidan was instructed to follow-up this matter and inform MEMAC and member states on the latest development.

The Chairman thanked Mr. Van der Burgt for his presentation and the Government of Holland for their concern and generous offer.

3. Approval of the Provisional Agenda

The meeting approved the Provisional Agenda as in (Annex IV).

4. Organisation of the Work

Considering the Holy Month of Ramadan, the meeting agreed to hold its working sessions during the following hours:

Day session	10:00 - 14:00 hrs.
Evening session	21:00 - 24:00 hrs.

5. Report of the Director of Memac

The Director of MEMAC made an oral presentation of his report outlining the progress achieved since the Third Technical Meeting (Annex V). Additions and corrections were made under item (I) page 1 as follows:

State of Qatar : add "R/V Mikhtabar Al-Bihar available for collecting samples".

Kingdom of Saudi Arabia : delete "other items under consideration" and add "funds allocated and personnel available. Dhahran Airport to be used as take-off and landing base with fuelling and maintenance services. Port facilities also available".

Islamic Republic of Iran : Plan of Action approved subject to conditions outlined in document No. 2871/1 - 621 submitted to ROPME by the Embassy of the Islamic Republic of Iran in Kuwait on June 15, 1983. (Attachment I\* ).

Under item (III) it was pointed out that it was necessary to receive the CV's of international experts before their visits are agreed upon.

Under item (IV) Representatives of Qatar and Bahrain expressed special thanks to Saudi Arabia for continuously providing them with up-to-date surveillance information.

His excellency Dr. Abdul Rahman Al Awadi the Acting Executive Secretary of ROPME and ROPME Council Member, H.E. Mr. Jawad Al-Arrayed, Bahraini Minister of Health, joined the meeting at 1.15. H.E. Dr. Al-Awadi expressed his concern over the extent of oil pollution reaching the Bahraini shores. H.E. added that the whole pollution situation should be assessed.

---

\* Available only in Farsi through MEMAC.



It is important to determine whether or not the oil reaching the coastal areas is or is Not from Nawruz. H.E. emphasised that the Region is experiencing a very difficult situation specially if oil begins to reach the shores in large quantities.

His Excellency discussed with the Task Team members several issues connected with the Plan of Action. He stressed the need to consider all alternatives. H.E. informed the meeting that ROPME Council Meeting will be postponed until a final plan is prepared by the Task Team.

6. Detailed Contingency Plan

During the succeeding days, the Team began discussing in-depth item 5 of the Agenda in order to prepare detailed working plans for the implementation of the Plan of Action. The discussion was centred on 2 major items, surveillance and combatting.

Two mexican oil pollution experts Mr. Ing. Alejandro Rojas Rodriguez and Mr. S. Daniel Fregoso A. Manjarrez, presented their experience with the IXTOC-I oil spill incident. The presentation included a film and slide show on methods and technology used in combatting the oil pollution in the Campeche Bay.

Afterwards, the Task Team suspended its plenary session and formed two sub-committees; one to deal with matters related to surveillance and another to consider combatting operations. After two days of deliberation by the sub-committees, the chairmen of the sub-committees Mr. Ahmed Al-Awadi and Mr. Khalid Fakhro presented the reports on combatting (Annex II) and surveillance (Annex III). It was agreed by the meeting that these reports constitute the Plan of Action to be recommended to the ROPME Council (Attachment II).

7. Adoption of the Final Report

After detailed discussions and several revisions, the meeting approved the final report and Plan of Action including all attachments and annexes.

8. Acknowledgement

The meeting expressed their appreciation to Mr. Van der Burgt and the Dutch Government, Mr. Rojas Rodriguez and Mr. Daniel Fregoso Manjarrez and the Mexican Government, Captain Michael Garnett and IMO for their contributions and effective participation in the meetings. And to the Bahrain representative for arranging a visit to the oil polluted coastal areas.



9. Closing of the Meeting

The meeting was officially closed by the Chairman Dr. Nizar Tawfiq at 23:00 Hours on Wednesday June 29, 1983 after thanking all participants for their constructive participation.

LIST OF PARTICIPANTS

BAHRAIN

Mr. Ebrahim Hassan Salman  
Harbour Operations Officer  
Port Department  
P.O. Box 15, Manama, Bahrain  
Tel: 727130 (office)  
683061 (home)

IRAN

Mr. Farivar Razmazma  
D.O.E. Member Staff  
Department of the Environment  
Tehran  
Tel: 829201 (office)  
822798 (home)

Mr. Abbas Rezazadeh Saber  
Head of Production Planning and Engineering  
Iranian Offshore Oil Co.  
P.O. Box 1434  
Tehran, Iran  
Tel: 625969 (office)  
243022 (home)  
Telex: 212707 IOOC IR

IRAQ

Mr. Aktham Ahmed Abdul Haleem  
Harbour master (Marine pollution)  
The State Organisation of Iraqi Ports  
Basrah, Iraq  
Tel: 413211 Ext. 260 (office)  
211781 (home)

KUWAIT

Mr. Ahmed M.A. Al-Awadi  
Director of Refining and Gas  
Ministry of Oil  
P.O. Box 5077  
Safat, Kuwait  
Tel: 451672 (office)  
833619 (home)  
Telex: 22363 PETROL KT

KUWAIT (cont)

Mr. Sajed Nasser Al-Baijan  
Captain  
Ministry of the Interior  
Kuwait Coast Guard  
Tel: 842169 (office)  
818714 (home)

QATAR

Mr. Issa Hussain Al-Majed  
Director, Department of Meteorology  
P.O. Box 8658 Doha, Qatar  
Tel: 0974 320002 (office)  
0947 424278 (home)

Dr. Hassan A. Kushkush  
Secretary General, Environment Protection Committee  
P.O. Box 2357  
Doha, Qatar  
Tel: 320825 (office)  
328862 (home)  
Telex: 4579 EPC DH

SAUDI ARABIA

Mr. Nizar Ibrahim Tawfiq  
D.G. of National Meteorological and Environmental Centre, MEPA  
P.O. Box 1358, Jeddah  
Tel: 09662 6723953 (office)  
09662 6872196 (home)  
Telex: 401236 Arsad, SJ

Mr. Abdulwahab M.J. Dakkak  
Director of Natural Resources, MEPA  
P.O. Box 1358 Jeddah  
Tel: 09662 6710448 (office)  
09662 6716809 (home)  
Telex: 401236 Arsad, SJ

OMAN

Mr. Ahmed Ali Al-Sheryani  
Environmental Analyst  
Council for Conservation of Environment  
and Prevention of Pollution  
P.O. Box 5310 Ruwi  
Sultanate of Oman  
Tel: 704344 - office



OMAN (cont)

Dr. A.D. Matthews  
Marine Scientist  
CCEPP  
P.O. Box 5310 RUWI  
Sultanate of Oman  
Tel: 704007

UNITED ARAB EMIRATES

Col. Saif Alshafar  
U.A.E. Coast Guard  
P.O. Box 1788  
Dubai, U.A.E.  
Tel: 450250

OBSERVERS AND CONSULTANTS

Mr. C. Van der Burgt  
Netherlands  
Chief Engineer Director  
North Sea Directorate of the Ministry of Transport  
and Public Works (Rijkswaaterstaat)  
1 Koopmansstraat 2288 BC  
Rijswijk, Netherlands  
Tel: 070 949500 (office)  
Telex: 33782  
Observer of the Netherlands Government

M.J. Garnett  
Consultant to I.M.O.  
c/o International Tanker Owners Pollution Federation  
Staple Hall  
Stonehouse Court  
Houndsditch  
London EC3A 7AX  
Telex: 887514 (TOVLOP)  
Tel: 1 - 621 - 1255 (office)

Mr. Ing. Alejandro Rojas Rodriguez  
Sub Manager Environmental Protection Department  
Petroleos Mexicanos  
Ave Bahia Ballenas No. 5 Piso 10 <sup>o</sup>  
Mexico City, Mexico 11300  
Tel: (52) 250 8247, 5316429 - Office  
Telex: 1773062 and 1773676

Mr. S. Daniel Fregoso A. Manjarrez  
Chief of Information  
Environmental Protection Department  
Petroleos Mexicanos  
Ave. Bahia Ballenas No. 5 Piso 10<sup>o</sup>  
Mexico City, Mexico 11300  
Tel: 52531 - 6429 (Office)  
Telex: 1773062 and 1773676

ROPME PROFESSIONALS

Dr. Abdul Rahman Al-Awadi  
Acting Executive Director  
P.O. Box 26388  
Safat, Kuwait  
Tel: 410027  
Telex: 44591 KT

Mr. Abdul Latif Al-Zaidan  
Programme Co-ordinator/Director  
ROPME  
P.O. Box 26388  
Sabat, Kuwait  
Tel: 418782 - Office  
382465 - home  
Telex: 44591

Mr. Khalid Fakhro  
Director of MEMAC  
P.O. Box 23452  
Manama, Bahrain  
Tel: 275224  
Telex: 9890 Memac BN

Dr. Yadollah Khosravi  
Program Officer - Economist  
ROPME  
P.O. Box 26388  
Safat, Kuwait  
Tel: 410027-9 (office)  
564232 (home)  
Telex: 44591 KT

Dr. Manaf Behbehani  
Marine Scientist  
ROPME  
P.O. Box 26388  
Safat, Kuwait  
Tel: 0965 410027 (office)  
315648 (home)  
Telex: 44591 KT

REPORT OF THE SUB-COMMITTEES ON COMBATTINGINTRODUCTION

In accordance with the views expressed in the paper " Outline Methodology of combatting pollution in the Sea Area " attached to the final report of the third meeting of the Technical Committee, we have reviewed in depth the viability of the recommended use of oil skimming vessels (single ship system) as a first step to formulating a response plan.

PRACTICAL CONSIDERATIONS

The amount and extent of cover of oil on the surface of the sea in the rectangle agreed for operations is presently unknown, but most of this oil is expected to be a heavily weathered tary material. Until this is identified by surveillance it is not possible to initiate any form of response action. It must be born in mind that in all probability the natural dispersion of the oil will lead to less than twenty five tons of oil entering the area daily. This oil could well be spread over a front of many miles. The spread of the oil is all important since the encounter rate (swath width) of the skimming vessels is less than 40 metres and they will only be effective when steaming at less than two knots. If the oil is spread as expected one such vessel may only pick up two to three barrels of oil per day at the very most.

DESCRIPTION OF TECHNIQUE

Once oil in sufficient quantity is identified by surveillance aircraft the skimming vessel proceeds to the site and is positioned in the oil slick by the Helicopter. It is then imperative for a Helicopter to remain over head throughout the skimming operation to keep the skimmer vessel in the recoverable oil. Two Helicopters will be required to maintain one on task throughout the operation. Such operation can only be properly effective in calm conditions but can be partially effective in wave heights upto one metre.



The reasons for selecting this technique are described in our previous report No. 3 but the limitation detailed above must be borne in mind. There are a number of such vessel systems available some of which are described in more detail in the annex. Most of these could be effective if sufficient oil is concentrated to allow collection though their recovery systems and pumps vary and this could well prove to be the most important point in their selection. It should be borne in mind that the system that will be most effective in the fresh crude at the source of the spill may not be the best for collecting the more vicious and heavy patches of oil in the rectangle of operations. The capacity of the associated pump to move this oil is all important.

#### RECOMMENDATIONS

It is recommended that the only sensible practical and cost effective step to be taken is to carry out a trial of this selected technique using a locally available system. This trial to be carried out as soon as the surveillance operations confirms and identifies a suitable oil slick within the rectangle. Should the technique prove successful and a significant quantity of oil is collected the next step is to evaluate whether an operation based on this principle could be viable and cost effective. Although it is believed that operating close to the source give the best chance of success while operating some 100 miles away from the source it is bound to be extremely difficult and expensive. This will be dependent on the amount of recoverable oil in the rectangle, the rate of recovery achieved and the number of such systems and Helicopters required.

The view of the committee at the moment, based on the above is that such an operation could well result in the cost of each barrel of oil collected being in the region of \$US 1,000.

These costs could be dramatically reduced if operations were conducted adjacent to the source. It should be noted that the cost of a barrel of oil recovered at IXTOC well blow out was \$US 60.

It remains the view of the committee that the overriding requirements is for countries to continue to concentrate their endeavours on defending their priority areas for protection. At the same time that the surveillance operation be commenced and when the situation allows the recovery trial as described is carried out in the rectangle.

COST

The estimated cost to initiate implementation of this pilot plan is \$US 511,105

REPORT OF THE SUB-COMMITTEE ON SURVEILLANCEINTRODUCTION

According to the latest information given by the Iranian delegation on the status of the damaged wells in the Nawruz Field, the total leakage into the Sea Area is estimated at 4-5,000 bls/day. Well number 3 is leaking about 2,000 bls/day while platforms number 5 and 9 are still on fire with one and three wells on each platform respectively. Total of approximately 20,000 bls/day is discharging from these two platforms 2,000 barrels of which is flowing into the sea while the rest is burning. The conditions of the two platforms is worsening due to extensive heat and damage caused to their structure. The fire is reaching a critical level near the water surface. In the likely event of the fire being put out a total of 25,000 bls/day are expected to be discharged into the Sea Area.

Due to lack of co-ordinated air surveillance, it is impossible to define accurately the extent of any oil polluting the Sea Area.

Although it appears that presently there is direct threat to the shorelines, this could only be estimated and updated by continuous surveillances. This need will be accentuated should the flares go out, when an increased threat must be expected.

It is not only important to know where the oil is, but also to forecast its future movement. For this purpose and in compliance with the decision of the Third Technical Meeting. A Task Team met in Bahrain 25-30 June to discuss various aspects of the proposed Plan of Action. The following decisions were agreed upon.

I. ORGANISATION FOR CO-ORDINATION

For the commencement and follow-up of any activity outlined in the report of the Third Technical Meeting, it is important to form a central co-ordinating team based within Memac and be responsible to its Director. The co-ordinating team to be comprised of:

- 1) Co-ordinator
- 2) Operations Officer
- 3) Communications Operator
- 4) Accountant
- 5) Meteorologist

(see attached organisational chart).



The co-ordinating team is to have the following functions:

- a) co-ordinate all activities related to response operations to Nawruz oil spill.
- b) Supervise daily activities of surveillance and combat efforts.
- c) keep records of all financial arrangements related to response operations.
- d) keep accurate and up-to-date information system and prepare periodic progress reports of response activities and financial transactions.

To facilitate the teams activities additional equipment should be acquired by Memac (attachment 1).

## II. AIR SURVEILLANCE

Air surveillance activities are recommended to commence with the objective of identifying any oil present in the designated zone or moving into it in order to mop its movement and predict its fate. Such information should be useful to those countries which might be directly threatened. Furthermore, surveillance information will be necessary to determine whether or not combatting at high seas is to be undertaken.

### Area of Surveillance

The area to be covered by surveillance lies within the following co-ordinates:

Point A	NW	28°, 25' N	49°, 15' E
Point B	NE	28°, 50' N	50°, 32' E
Point C	SE	27°, 44' N	51°, 03' E
Point D	SW	27°, 25' N	50°, 03' E



This area is to be sub-divided into 5 x 5 nautical mile squares for ease and accuracy of reporting.

On a large scale, the area is to be divided along the Geneva Line into two sections. Surveillance in the Eastern section to be implemented by the Iranian authorities. The Western section to be implemented by the Saudi authorities.

Surveillance to be conducted by visual observation from Helicopters which will be provided by the Islamic Republic of Iran and the Kingdom of Saudi Arabia.

Surveillance operations to be conducted from Jubail for the Saudi helicopter and Boushehr for the Iranian helicopter. Khafji, Al Arabia Island and Al-Safaniaoil field to be used for re-fuelling of the Saudi helicopter while Foruzan oil field to be used for re-fuelling of the Iranian helicopter.

Two supporting crew boats would be deployed in these areas for the purpose of collecting samples for later handling by MEMAC and confirming sightings. Boats are to be supplied by Iran and Saudi Arabia.

While boats can move freely throughout the designated zone, helicopters will be restricted to the Geneva Line.

If surveillance helicopter is not equipped with VHF marine band FM communications systems, then the ships must carry a portable VHF air band AM set (e.g. Marco TR 1000 B) with 72 channels operating in between 118.000 to 135.975 MHZ. This equipment will give a range of up to 50 miles over the sea.

It is advisable to utilize the services of Qatar Research vessel suggested by delegates of Qatar for collecting and analysing oil, water, sediment and plankton samples for analyses.

#### COST

The estimated cost to implement this plan is \$US 488,895

NOWRUZ OIL SPILL INCIDENT  
FIRST MEMAC TASK TEAM MEETING  
BAHRAIN, 25-29 JUNE, 1983.

AGENDA

1. Opening of the meeting.
2. Organization of the work.
3. Adoption of the agenda.
4. MEMAC's report on progress achieved since the Third Technical Meeting.
5. Formulation of a detailed contingency plan for the implementation of the plan of action proposed by the Third Technical Meeting.
6. Adoption of the plan of action.
7. Closing of the meeting.



# Marine Emergency Mutual Aid Centre

---

MEM/TT 1.2 (NOWRUZ)

Nowruz Oil Spill Incident  
First Memac Task Team Meeting  
Bahrain: 25-30 June 1983

REPORT OF THE DIRECTOR OF MEMAC

## INTRODUCTION

In the Interim period between the Third Technical Meeting held in Bahrain 7-8 May 1983 and this first Task Team Meeting, MEMAC has implemented the tasks assigned to it by the Third Technical Meeting. For this purpose MEMAC has contacted all ROPME National Focal Points and companies specialized in the Oil Spill response as well as other Governments and International Organisations. The results of these activities are presented below:

### (I) Response of ROPME National Focal Points to the Plan of Action suggested by the Third Technical Meeting:

- STATE OF BAHRAIN: Approved the Plan of Action and requested additional details on surveillance program to respond on helicopter request. No vessels or laboratory facilities are available.
- REPUBLIC OF IRAQ: Requested additional information. MEMAC responded and is now awaiting further response from Iraq.
- STATE OF KUWAIT : No response received.
- STATE OF QATAR : Can provide laboratory for analyses of oil samples for Vanadium and Nickel only. No response on remaining items.
- KINGDOM OF SAUDI ARABIA: Approved the Plan of Action. Will provide a vessel for surveillance and sampling. Other items under consideration.
- SULTANATE OF OMAN : Items requested for Plan of Action not available. Helicopter could be hired from Oman Aviation Services.
- UNITED ARAB EMIRATES : No response received.
- ISLAMIC REPUBLIC OF IRAN: Approved the plan of action. Will contribute a suitable helicopter as well as one vessel.



(II) Response of Governments, Companies and Institutions  
to MEMAC's inquiry about suitable vessels for comb-  
atting the oil slick:

In compliance with the recommendations of the Third Technical Meeting, which called for sending telexes to some companies in order to secure a practical proposal for the removal of oil, telexes were sent to 30 selected government agents, companies and institutions. As recommended the characteristics of oil found in the Sea Area were given.

MEMAC received replies from 15 companies and 3 government agencies. The responses varied from simple to detailed information. Below the names and addresses of offerers and summary of the nature of their offers are presented:-

1. The Netherlands Joint Government and Private Sector

Offer: Telex HOLLUW 22459 KT.

---

Group of Dutch companies forming the Dutch Oil Pollution Combat Consortium has equipment available that can deal with all sorts of oil spills.

The following is a review of the proposal supplied by Netherlands Mission of the region, to assist in combatting the oil pollution.

The Pollution Combat Group consists of ten participants governmental and public organisations; who are highly experienced and competent in fighting oil spills like the Nowruz oil spill. Each one of the participants is specialized in handling a particular field of the total operation for achieving satisfactory results.

The group will be totally responsible and reporting to the Ministry of Transport and Public Works, who will be in charge of the project.

The primary step of the industrial companies represented by discussions/co-ordination between representatives of Dutch Government and the respective governments in the Region for the combat of the oil slick.

Since some of the industrial companies represented by the group are already in the Region on different assignments, joint activities augmented by the help of local operators could be highly effective and result oriented.

Initial steps should be worked out for collection of data on the following terms:

- a) about the oil spill, total area, positions,
- b) evaluation of critical/sensitive areas such as desalination plants, power plants, etc.
- c) gather exact details about current direction/wind direction which naturally will have a strong impact on the oil surface and submerged oil/tar lumps.

For the above purpose, aircraft fitted with Radar and infrared/UV Scanner could be used in addition to computers and other equipments/instruments.

Once the decision for collection of required data is taken, next stage of action should be started immediately, as described below:

- a) Collection of samples for analysis to find out viscosity, density, water content, pourpoint, etc. Samples should be collected from different areas of the spill to ascertain the exact properties contained at different stages.
- b) Depending on the properties contained in the oil, feasible equipments/vessels, for example skimmers could be used for recovering the oil from the surface of the water.
- c) As for submerged oil/tar lumps, etc., long stationary nets and trawl recovery systems could be applied for best results.
- d) Near the spill point, booms have to be used to prevent spreading of oil, and to concentrate within an area for easy recovery. Boom sizes can be increased depending on the necessity. For deep water area operation, this method will be quite effective.
- e) Coastal cleaning operation: shallow draft equipments could be used since large vessels will not be able to operate in coastal area.



- f) As regards sensitive areas, different methods could be used such as barriers of booms and nets, deflections by booms, construction of permeable dam(s) of sand or gravel, installation of air bubble screens etc....etc.

From the commencement of operation, there should be radio communication among air-surveillance group, surface vessels and on-shore control centre, without which the operation will not be effective.

Once the oil recovery operation has been started, treatment of recovered material should also be simultaneously carried out in conjunction with relevant necessary arrangements.

2. The Norwegian State Pollution Control Authority  
(OSPACA), Oslo Telex 76684 SFT N
- 

They offer one Sooper Oil Recovery System. The details are included in the telex documentation. No price is given

3. Federal Republic of Germany (GERCOM)  
Telex 238914 RMC D
- 

They offer wide variety of equipments and services including 2 vessels called "Schorhon" and "Thor", suitable in this incident. No comment on the financial arrangement.

4. SESAM/FRANCE Telex SESAM 202268 F
- 

Their vessel is suitable for near shore, shallow waters.

- They suggest the use of a special net designed by the French Institute of Petroleum which is suitable for weathered oil and tar balls.
- Price details are given in telex.

5. Westchase Transportaion Group Al-omar Mechanical  
Engineering Co. Telex 22152 OMARCO KT
- 

.....5..ctd.

....5..ctd.

- Offered equipment suitable for the removal or the type of oil specified in the telex.
  - Services and equipment will be provided within seven days.
  - Company has experience in the Mexican IXTOC-1 oil spill,
6. Smit International Co./National Services Co Mohammad Rafie Hussain Marafie Sons & Co.

Telex 22661 KT

---

- Proposed system is suitable for all types of oil specified at ambient temperature.
- No financial terms are given.

7. McDermott International, Inc.

Telex 45437 JARMC EM

---

— Promised to provide detailed information later.

8. Van Latten, Export GMB

Telex 24714 LAROE D

---

- They suggested normal recovery vessels are useless, recovery is only effective with large size special vessels with systems which can carry and trawl nets. The vessels are ready for use on short term.

9. Det Norske Veritas

Telex VERITAS 23533 KT

---

- No positive response was given regarding vessel but specified that they issue rules and regulations for constructing new vessels.



10. Atlas Co.

Telex 246882 ATLAS D

---

- System suitable for specified types of oil.
- The end product is fine powdered, water proof material which can be temporarily stored in containers on board ships and used for street substructure.
- Delivery 5-6 months.
- No financial terms given.

11. Scandinavian Environmental Protection Service

Telex 32314C HANMLM S  
32158Y PUBTM S

---

- System suitable for types of oil specified.
- The vessel is multipurpose.
- No financial terms given.

12. Camnalco/Lamnalco Ltd

Telex 22962 NALCO KT

---

- Vikoma Sea Wolf Skimmer is suitable. It is designed for recovery of mats, rafts, tar balls, debris, etc.
- Drawings and specifications sent by post.
- Price of each unit given.

13. Hayat Trading and contracting Corp., Kuwait/ T.I.Corp.  
France Telex 22916 (A/B HABIB KT)

---

- Van Putten vessel capable of handling all types of oil.
- Prototype available for inspection in Paris.
- Company will sell know how for US27,500,000 dollars.
- 30,000 tons per day could be recovered if complete system is provided.

14. Environmental Science and Engineering  
Telex 810-825-6310 USA

---

- Company does not have vessels but can offer advanced model of beach cleaner.
- Company has experience in Hasbah 6 Oil Spill on Qatari beach.

15. Industrial Metal Centre Kuwait/Mobas Ltd Japan  
Telex INMETCO 22944 KT

---

- Oil skimming vessel type MIPOS/17 CNF Bahrain Cost 195,500,000 JY.
- Delivery within 210 days.
- Offer does not include supervisory fees.
- Offer subject to approval of Japanese Government.

16. Marine and Industrial Services GMBH  
Telex 238510 MIS D

---

- Offering an oil removal vessel "Thor" to skim oil from water surface, oil Removal "CREP System" for liquifying the heavily weathered oil from the sea water, and oil removal equipments for beach cleaning.
- Price details are given and specified. One week delivery time after receipt of order.

17. Mattssonprodukter AB  
TElex 42284 MPAB S

---

- Offer oil skimmer system "WALOSEP" which can handle floating and pumpable types of oil.
- More details are given in the related telexes.

18. Framo Mohn A/S, Bergen-Norway

Telex 42073Z FRAMO N

---

- Offering a standard unit fitted with oleophilic discs, the weir (pumpwell) can be adjusted to minimum position (80 MM. under oil/sea level) in order to pick up extreme high viscous oils and solids.
- Subject the oil spill only consists of tar balls and similar solids, the disc drum can be replaced with four shovels enabling easier transport of cargo to the oil transfer pump.
- The oil transfer pump built into the skimmerhead is a framo TK6 pump with stated performance in handling oil and solids with viscosity up to 120.000 sec. redwood no., 1(4.8 Degrees C) (U S C G test).
- Price, payment conditions and delivery time are given in their telex.

(III) Experts/Consultants:

UNEP has been contacted by MEMAC to nominate experts to join the task team in order to help in preparing detailed plan of action. Accordingly an IMO expert on stand-by is available to join the task team whenever he is needed.

The Government of Mexico expressed their interest in sending a team of 2-3 experts who actively participated in a similar spill IXTOC-1, to join the task team in order to help and gain experience. A team of two experts is expected to arrive in Bahrain on 26th June 1983.

The Government of Japan have also expressed their interest in assisting with their expertise who could be made available upon request.

Many other Governmental and private companies and agencies have offered their consultancy services.



(IV) General Comments:

Since the 27 of January 1983, the oil is being discharged into the Sea Area and yet we know very little about the rate of discharge and the areas effected by this spill. Being the coordinating regional centre Memac is in continuous contact with all member states, seeking their response regarding the surveillance, observation, and readiness for combatting the spill in compliance with the recommendations of the technical meetings as well as functions and duties of Memac as per the Kuwait convention and its protocol concerning regional cooperation in combatting pollution by oil and other harmful substances in case of emergancy.

Unfortunately, the response is irregular and incomprensive. Hence Memac has received very little and limited information regarding the state of pollution.

However, I would like to point out that, without the information we recieved from the Kingdom of Saudi Arabia and Bahrain, Memac would have had no regional report on this incident.

The adverse affect of this spill on the marine environment is well known to all, therefore, it is deemed very necessary to cap the wells while implementing the plan of action suggested by the Third Technical Meeting.



ACTION TEAM, FINANCIAL  
AND OTHER REQUIREMENTS  
FOR SURVEILLANCES

Action Team consists of the following:-

- 1 - Co-ordinator
- 2 - Operation Officer
- 3 - Communication Operator
- 4 - Accountant
- 5 - Meteorologist

I. Co-ordinator

Within the framework of the Plan of Action, under the supervision of the Director of Memac, the duties of the co-ordinator and his team are inclusive but not limited to:

Duties

1. Co-ordinate and follow-up all activities related to oil pollution response including surveillances, combatting, disposal, sampling and analysis.
2. To utilize expertise available within Ropme on environmental aspects of pollution in particular clean-up of disposal methods.
3. Prepare periodic progress reports on activities.
4. Review and recommend different techniques and Methodologies as deemed necessary.

Qualifications

1. Experience in oil spill clean-up.
2. Have leadership quality.

## II. Operation Officer

### Duties

1. Advise on selection of appropriate machinery, equipment and materials for surveillance and combatting.
2. Schedule surveillances, combat and disposal operations.
3. Maintain contact with each base co-ordinator.
4. Perform any other duties assigned to him by the co-ordinator.

### Qualifications

1. Marine background
2. Familiar with offshore oil industry
3. Good background and experience with oil pollution techniques.

## III. Communications Operator

### Duties

1. Operating general communication equipment especially teleprinter and facsimily.
2. Operating telex machine.
3. Provide preventive maintenance for communication instruments.
4. To report to Operation Officer.

### Qualifications

1. Minimum experience of 3 years in this field.
2. Reasonable command of English.



IV. Meteorologist

Duties

1. Interpret, read and issue the forecasted information.
2. Issue specialised forecast.
3. Classify and assimilate all Met Data received from member states for prediction, Trajectory modelling as well as surveillances and combatting operation.
4. Perform any other duties assigned to him by the co-ordinator.

Qualifications

1. Diploma in forecast or equivalent and experience in marine meteorology, a minimum of two years.

TITLE : Accountant

DUTIES :

Under the supervision and guidance of the Director of MEMAC, the candidate will be responsible for, but not limited to, the following:

- Preparation of the Budget estimates and control of expenditure in implementation of financial rules and regulations of the operation.
- Disbursement of Cash funds.
- Payment of salaries and allowances to professional personnel and General Service staff, visiting experts and participants of meetings.
- Dealing with incoming and outgoing correspondence regarding financial matters.
- Monitoring day-to-day expenditure against various project codes.
- Preparation of travel requests, insurances, purchase orders, financial contracts and obligating documents.
- Handle financial arrangements for meetings organised or serviced.
- Keeping adequate property control records.
- Assist in any other financial matters related to the operation of the Organisation as required by the Finance Officer.

QUALIFICATIONS :

1. University Degree or equivalent in Accountancy.
2. Minimum of three years of professional accounting experience.

To facilitate the teams activities the following should be acquired by MEMAC:

- 1) two additional telephone lines
- 2) an additional telex machine
- 3) one facsimily receiver
- 4) one teleprinter receiver
- 5) additional secretariate services
- 6) additional transportation.



Cost estimate for Action Team salaries  
and surveillance requirements

I SALARIES

<u>Position</u>	<u>Monthly salary (BD)</u>		<u>Travel expenses</u> (BD)
	<u>min.</u>	<u>max.</u>	
Co-ordinator	2,500 *	3,000 *	2,500
Operation Officer	2,000 *	2,500 *	2,500
Communication operator	300	500	-
Meteorologist	500	1,000	-
Accountant	400	800	-
Secretary	250	500	-
Overtime and temp. services	-	900	-
	<u>5,950</u>	<u>9,200</u>	<u>5,000</u>
Sub-total for 6 months	35,700	55,200	5,000
Total for 6 months (maximum)		BD 60,200	
		<u>          </u>	
15% Contingency		BD 9,030	
Grand Total		BD 69,230	

\* include housing and transportation allowances

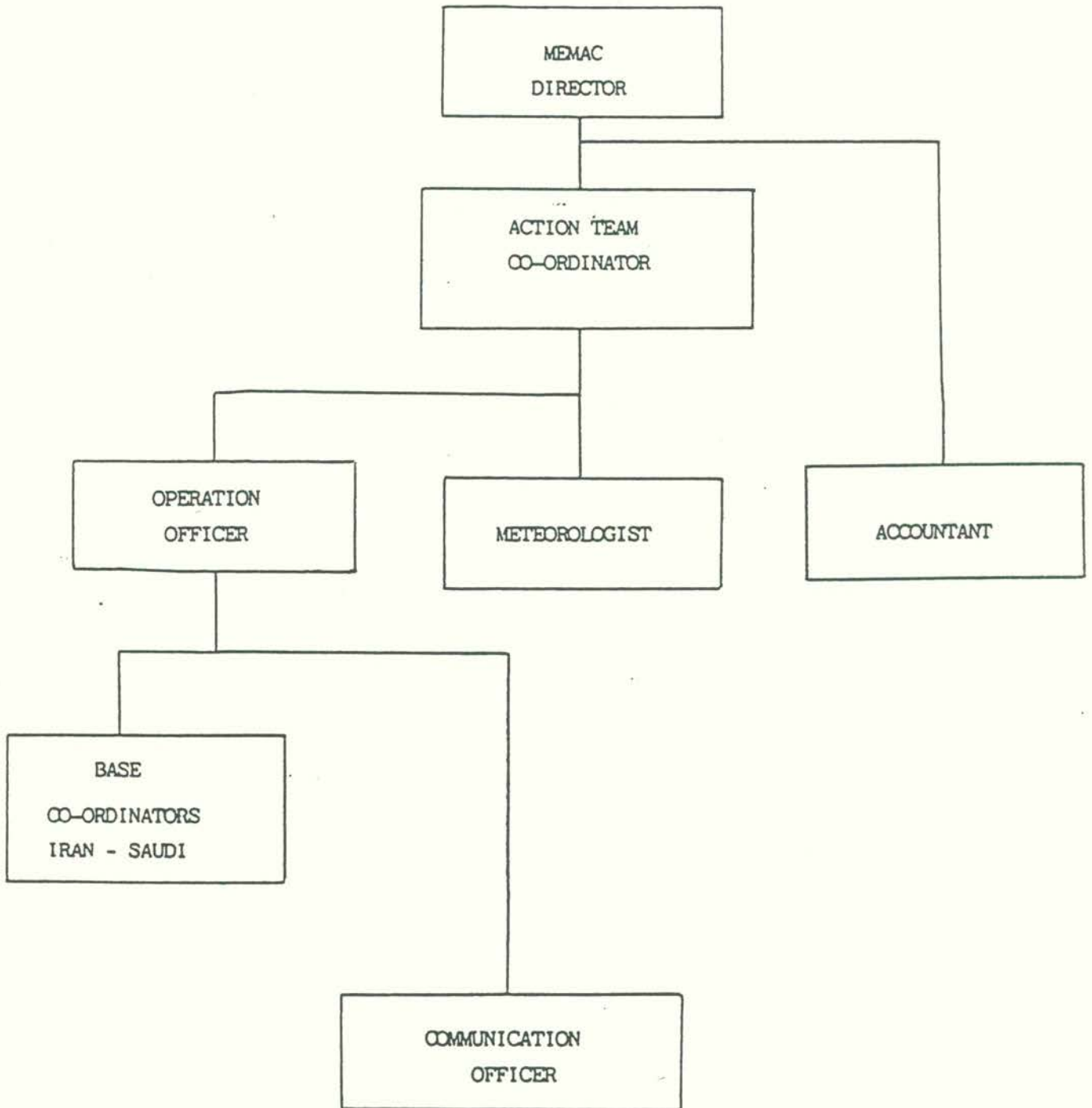
II NON-EXPENDABLE ITEMS

	BD
1 - Communication facilities (facsimily, teleprinter, receiver etc.)	15,000
2 - Additional office furniture	5,000
3 - Land cruiser vehicle	7,000
4 - Spare parts	1,000
	<hr/>
TOTAL	28,000
5% contingency	1,400
	<hr/>
GRAND TOTAL	29,400
	<hr/> <hr/>

III	<u>EXPENDABLE ITEMS</u>	BD
1 -	Stationery	10,000
2 -	General Services (Telegraph, Telex, etc.)	15,000
3 -	Sample analysis	10,000
4 -	Data analysis	5,000
5 -	Sampling instruments (bottles, glassware etc.)	2,000
6 -	Final report cost	5,000
7 -	Consultants	15,000
8 -	General maintenance	2,000
9 -	Miscellaneous	4,000
10 -	Insurance	15,000
	TOTAL	<u>83,000</u>
	5% contingency	4,150
	GRAND TOTAL	<u><u>87,150</u></u>

The total estimated cost for 6 months is ED185,780

ORGANIZATIONAL CHART - PLAN OF ACTION.





INTERNATIONAL MARITIME  
ORGANIZATION



UNITED NATIONS  
ENVIRONMENT PROGRAMME



Attachment II

to

MISSION REPORT

of the IMO/UNEP Consultant to the  
First MEMAC Task Team Meeting  
Bahrain, 25-29 June 1983

TECHNICAL INFORMATION PAPERS NOS. 1 - 5

The present Report is submitted under the sole responsibility of the Consultant, and does not commit the United Nations or IMO, which do not necessarily endorse the opinions set forth.

INTERNATIONAL MARITIME  
ORGANIZATION



UNITED NATIONS  
ENVIRONMENT PROGRAMME



Attachment II

to

MISSION REPORT

of the IMO/UNEP Consultant to the  
First MEMAC Task Team Meeting  
Bahrain, 25-29 June 1983

TECHNICAL INFORMATION PAPERS NOS. 1 - 5

The present Report is submitted under the sole responsibility of the Consultant, and does not commit the United Nations or IMO, which do not necessarily endorse the opinions set forth.

## TECHNICAL INFORMATION PAPER

Number 1

1981

# AERIAL OBSERVATION OF OIL AT SEA

### Introduction

Aerial reconnaissance is essential for an effective response to oil spills, both to facilitate the location of oil at sea and to improve the control of clean-up operations. It is necessary to locate the oil in order that timely measures may be taken to protect coastlines threatened by pollution. However, finding the oil and then interpreting its appearance in terms

of amount and type is often difficult. Weather and sea state in the search area can be unfavourable and the resemblance between floating oil and other phenomena is frequently deceptive. The aim of this leaflet is to illustrate some of the common pitfalls in aerial observation of oil floating at sea and to identify reliable reporting practices.



Figure 1. A major tanker spill of crude oil viewed from 300-500m height (1000-1500ft.). Extensive coverage of sheen and emulsified crude oil appearing as the lighter blue area in the right half of the picture.

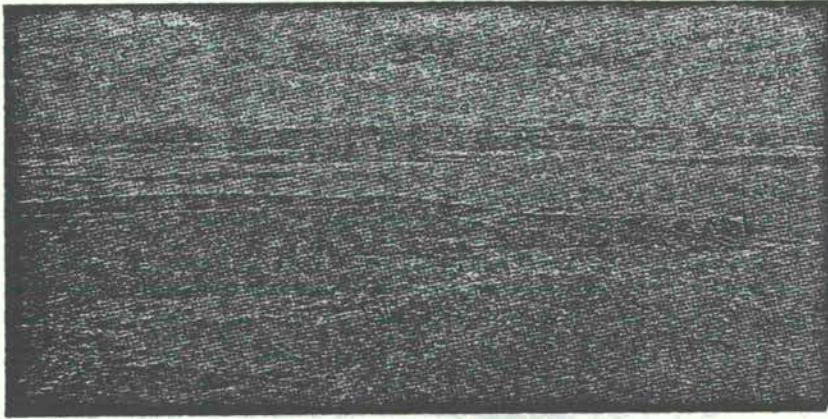
### Preparations for aerial reconnaissance

The aircraft chosen for aerial observation must feature good all round visibility and carry suitable navigational aids. Over nearshore waters the flexibility of helicopters may provide an advantage, for instance, in surveying an intricate coastline with cliffs, coves and islands. However, over the open sea the requirements for rapid changes in flying speed, direction and altitude are less acute and instead the speed and range of fixed-wing aircraft are generally desirable. For extensive surveys over remote sea areas, the extra margin of safety afforded by a twin or multi-engined aircraft is essential and may in any case be required by government regulations. Attention to safety must always be of paramount importance and the aircraft pilot should therefore be consulted on all relevant aspects of a reconnaissance flight.

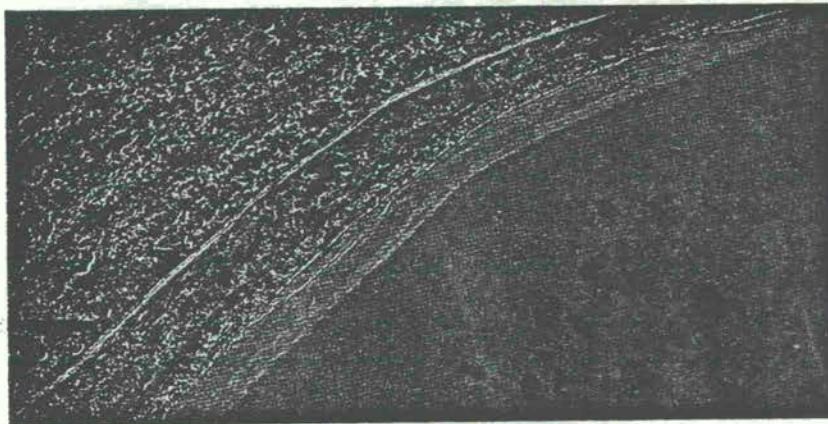
A flight plan should be prepared in advance using a chart of appropriate scale and taking account of any available information which may reduce the search area as much as possible. To avoid confusion it is often advisable to draw a

grid on the chart so that any position can be positively identified by a grid reference. For example, the grid squares may each represent one square mile. The task of forecasting the position of the oil is simplified if data on winds and currents are available since both agents contribute to the movement of floating oil. The mechanism whereby surface movement is induced by wind stress is imperfectly known, but it has been found empirically that floating oil will move downwind at about 3% of the wind speed. In the presence of surface currents, an additional movement of the oil proportional to the current strength will be superimposed on any wind-driven motion. Close to land, the strength and direction of any tidal currents must be considered when predicting oil movement, whereas further out to sea the contribution is less significant in view of the cyclic nature of tidal movement. Thus, with a knowledge of the prevailing winds and currents, it is possible to predict the rate and direction of movement of floating oil from a known position, as shown in the diagram on Page 5.

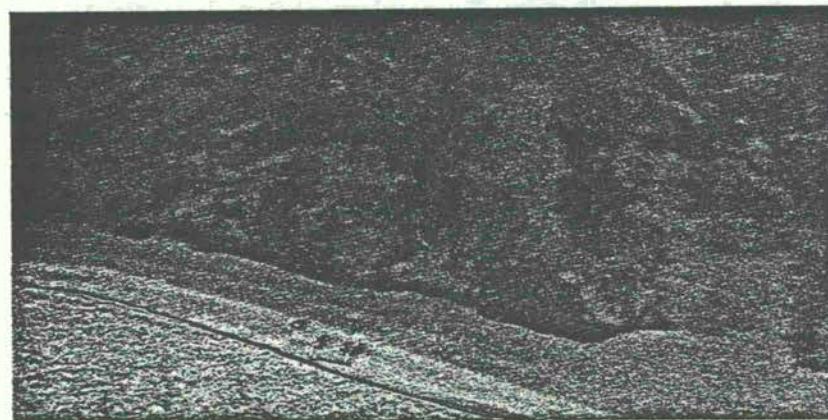




*Figure 2.* Prominent dark cloud shadows resembling floating oil.



*Figure 3.* Underwater growths of seagrass resembling patches of black oil. Altitude 500m (1500ft.).

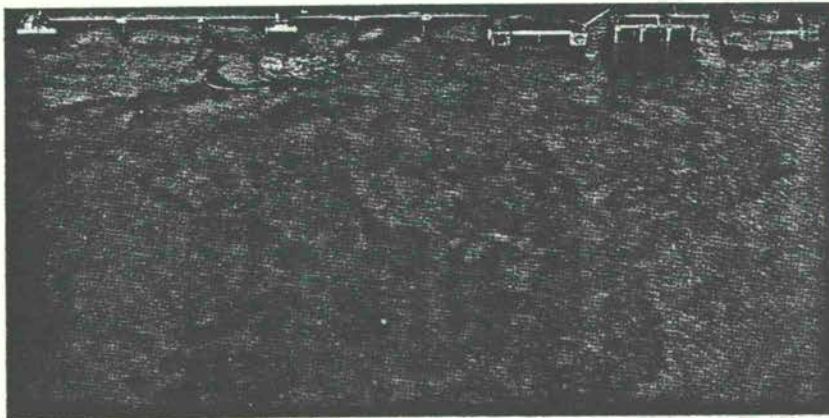


*Figure 4.* Underwater growth of seagrass resembling floating oil close to a sandy beach. Altitude 400m (1200ft.).

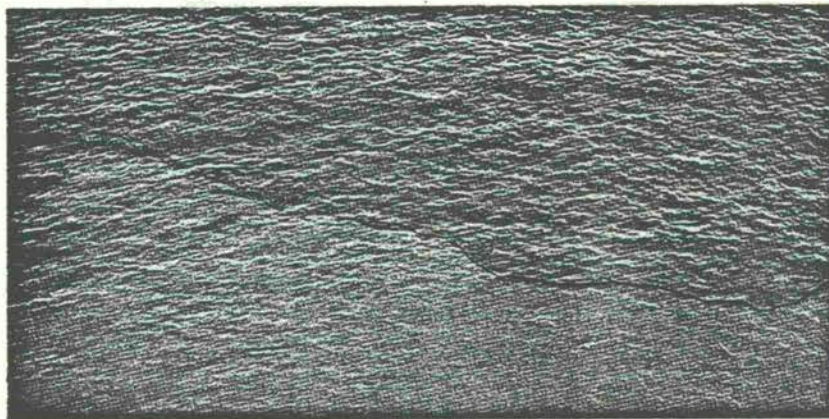


*Figure 5.* Nearshore waters loaded with suspended sand particles contrasting with clearer blue waters further offshore. Altitude 500m (1500ft.).

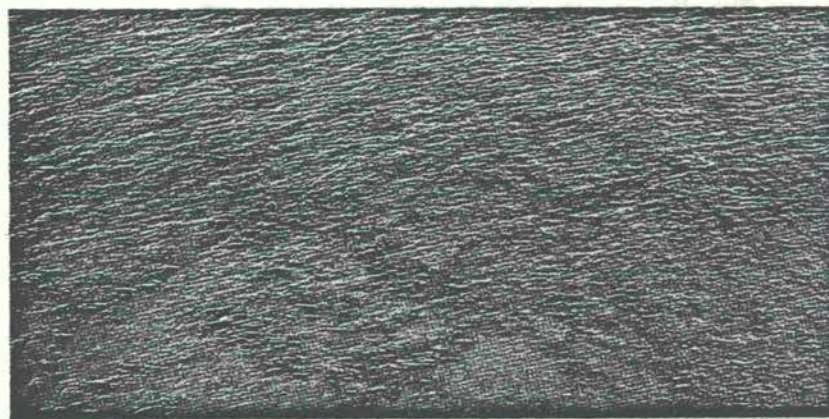




*Figure 6.* Freshly released crude oil spreading over calm water. Altitude 150m (500ft.).



*Figure 7.* Heavily emulsified crude oil after 9 days at sea. The sharp edge of the mousse suggests a thickness of more than 1mm. Altitude less than 50m (150ft.).

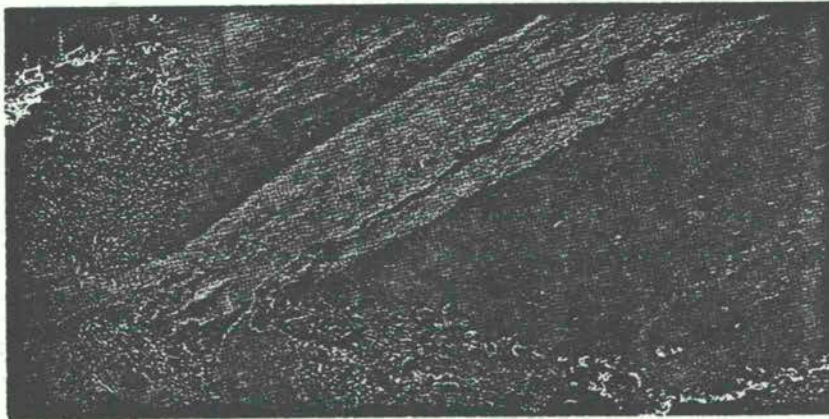


*Figure 8.* Emulsified crude oil in the process of fragmentation and dissipation after 9 days at sea.

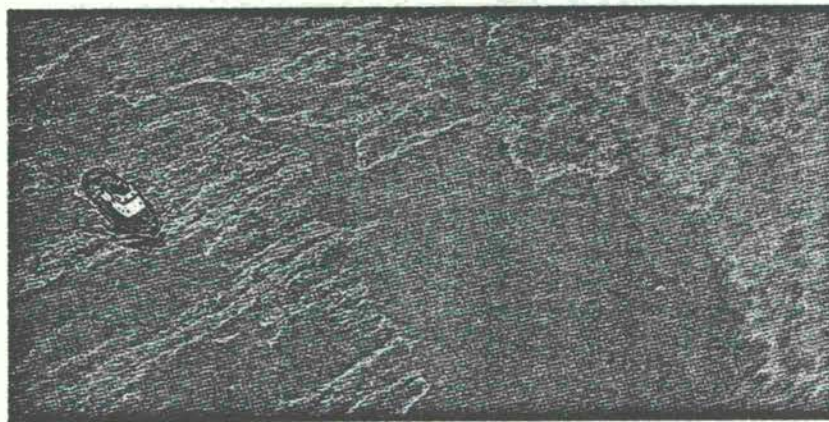


*Figure 9.* Emulsified crude oil accumulated against a shingle beach by an onshore wind. The wedge of oil formed in this way can be several cm thick if the wind is sufficiently strong.

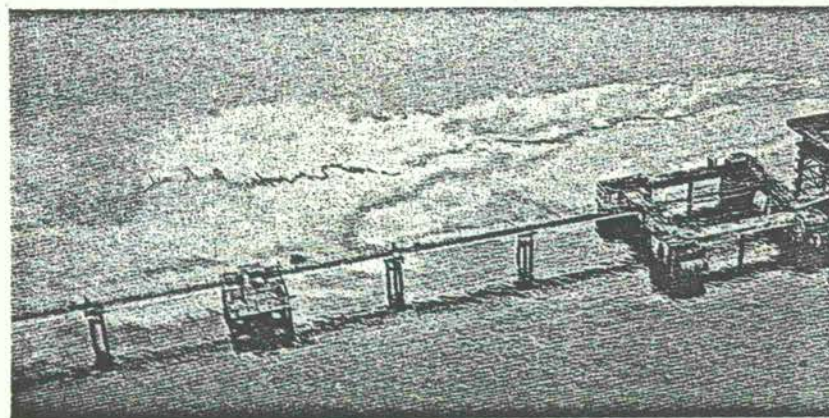




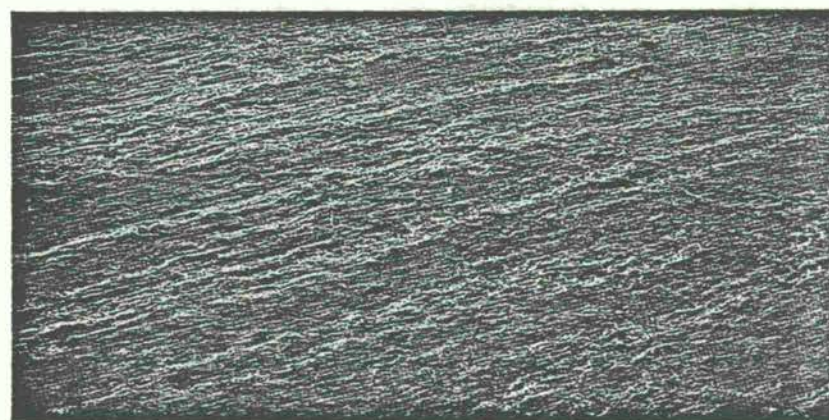
*Figure 10.* Emulsified fuel oil and sheen carried off a rocky shore by an offshore wind 4 days after a spill.



*Figure 11.* Cohesive slick of heavy fuel oil surrounded by streaks of sheen, about 24 hours after the spill.

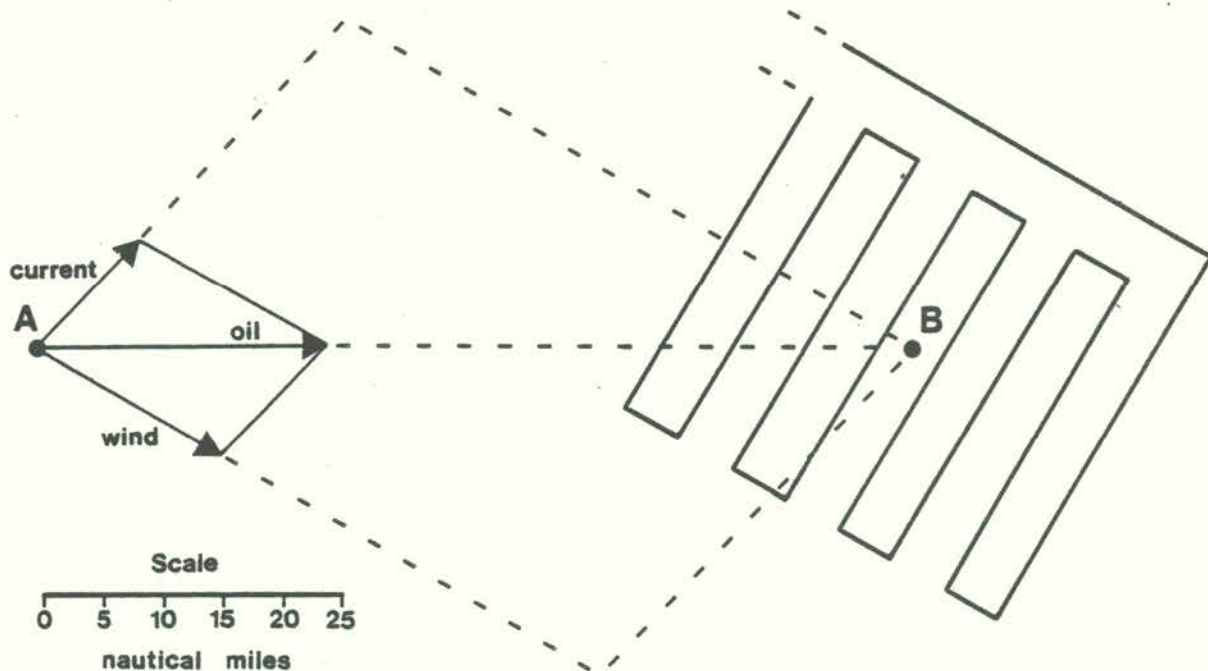


*Figure 12.* Iridescent sheen edged by silvery sheen. Viewed from 50m (150ft).



*Figure 13.* Windrows of emulsified fuel oil and silvery sheen. The wind is blowing from right to left at a strength of approximately 20 knots. Photograph taken 4 days after a spill.





*Movement of oil from last known position (A) to predicted position 3 days later (B). Wind speeds of 25 knots and current speeds of 0.5 knots prevail in the directions indicated. Arrow lengths represent distances applicable to movement during 24 hours. A cross-wind ladder search pattern over B is shown with a flight path separation of 5 miles, chosen with regard to visibility.*

In view of the errors inherent in oil movement forecasting, it is usually necessary to plan a systematic aerial search to ascertain the presence or absence of oil over a large sea area. A 'ladder search' is frequently the most economical method of surveying an area (see diagram) providing due attention is paid to visibility, flight altitude, flight duration, fuel availability and any other advice the pilot may give. Since floating oil has a tendency to become aligned in long and narrow windrows parallel to the direction of the wind, it is advisable to arrange a ladder search across the direction of the prevailing wind to increase the chances of oil detection. Another consideration is the possibility of haze and dazzle off the sea which often affects visibility. Depending on the position of the sun it may prove more profitable to fly a search pattern in the opposite direction to the one originally planned. Sun glasses can give the observersome relief from eye strain caused by strong light, and indeed, glasses with polarising lenses will actively assist the detection of oil at sea under certain light conditions on account of the polarisation differences in light reflectance off oil and off water. The search altitude is generally determined by the visibility prevailing. In clear weather 500 metres (1500 feet) frequently proves to be optimum for maximising the scanning area without losing visual resolution. However, it is necessary to drop to half this height or lower in order to confirm any sightings of floating oil or to analyse its appearance. Over the open sea away from any obvious reference points it is easy to become disorientated. Ideally an observer will have the opportunity of consulting the aircraft instrumentation in order to ascertain speed, direction and position, but in such an event it is worth ensuring beforehand that reading the instruments will present no difficulty. In the absence of such aids, an observer with a suitable chart can keep track

of course changes and positions by communicating with the pilot. Headsets can be very helpful in this regard.

#### **Appearance of oil at sea**

From the air it is notoriously difficult to distinguish between oil from spills and a variety of other unrelated phenomena. These include cloud shadows (Fig. 2); ripples on the sea surface; seaweed patches in shallow water (Figs. 3 & 4); differences in the colour of two adjacent water masses (Fig. 5); and sewage discharges. It is necessary therefore to verify initial sightings of suspected oil by overflying the area at a sufficiently low altitude to allow positive identification. A particularly difficult task is to distinguish between operational tank washings from passing vessels and oil originating from an accidental spill. The smaller quantity and coverage of tank washings together with their symmetry are usually indicative.

Crude or fuel oils spilt at sea undergo marked changes in appearance with the passage of time in response to evaporation, emulsification and other processes known collectively as 'weathering' (Figs. 6-13). Most oils spread laterally under the combined influence of gravity and surface tension, forming continuous slicks of thick dark oil which gradually thin into iridescent or silvery sheen at the edges (Fig. 6). Some crude oils and heavy fuel oils are exceptionally viscous and tend not to spread much, but remain in rounded patches surrounded by little or no sheen (Fig. 11). Slicks are soon broken up into windrows typically with 30-50m separation and lying roughly parallel to the wind direction (Fig. 13). Spills of crude oil and some fuel oils are frequently attended by the rapid formation of water-in-oil emulsions ('mousse') which are often characterised by a brown/orange colouration and a cohesive appearance (Fig. 7).



### Quantifying floating oil

An accurate assessment of the quantity of any oil observed at sea is virtually impossible due to the difficulty of gauging the thickness and coverage of floating oil. At best, the correct order of magnitude can be estimated by considering certain factors. The gravity-assisted spread of spilt oil is quite rapid and most liquid oils will soon reach an equilibrium thickness of about 0.1mm characterised by a black or dark brown appearance. Similarly, the colouration of sheen roughly indicates its thickness (see the Table). A reliable estimate of water content in a 'mousse' is not possible without laboratory analysis, but accepting that

figures of 50% to 70% are typical, approximate calculations of oil quantities can be made, given that most typical floating 'mousses' are about 1mm thick. However, it should be emphasised that the thickness of 'mousse' and other viscous oils is particularly difficult to gauge because of their limited spreading. Indeed in cold waters some oils with high pour points will solidify into unpredictable shapes and the appearance of the floating portions will belie the total volume of oil present. The presence of ice flows and snow in such conditions will confuse the picture yet further.

Table — A Guide to the Relation between the Appearance, Thickness and Volume of Floating Oil

Oil Type	Appearance	Approximate thickness	Approximate Volume (m <sup>3</sup> /km <sup>2</sup> )
Oil sheen	silvery	>0.0001mm	0.1
Oil sheen	iridescent	>0.0003mm	0.3
Crude and fuel oil	black/dark brown	>0.1mm	100
Water-in-oil emulsions ('mousse')	brown/orange	>1mm	1000

In order to estimate the amount of floating oil it is necessary not only to gauge thickness, but also to determine the surface area of the various types of oil pollution observed. Again, accurate estimates are complicated by the patchy incidence of floating oil. To avoid distorted views, it is necessary to look vertically down on the oil when assessing its distribution. By estimating the percentage coverage of the oil type in question, the actual area covered relative to the total sea area affected can be calculated from timed overflights at constant speed. As shown by this paper, photographs will sometimes allow the percentage of floating oil to be calculated more accurately and the use of an instant picture camera can therefore be valuable.

To illustrate further the process of estimating oil quantities the following example is given:

"During aerial reconnaissance flown at a constant speed of 150 knots, crude oil 'mousse' and silver sheen were observed floating within a sea area, the length and width of which required respectively 65 seconds and 35 seconds to overfly. The percentage cover of 'mousse' patches within the contaminated sea area was estimated at 10% and the percentage cover of sheen at 90%."

From this information it can be calculated that the length of the contaminated area of sea measured is:

$$\frac{65 \text{ (seconds)} \times 150 \text{ (knots)}}{3600 \text{ (seconds in one hour)}} = 2.7 \text{ nautical miles}$$

Similarly, the width of the sea area measured is:

$$\frac{35 \times 150}{3600} = 1.5 \text{ n.m.}$$

giving a total area of approximately 4 square nautical miles or 14 square kilometres. The volume of 'mousse' can be calculated as 10% (percentage coverage) of 14 (square kilometres)  $\times$  1000 (approximate volume in m<sup>3</sup> per km<sup>2</sup> — from table). As 50-70% of this mousse would be water, the volume of oil present would amount to approximately 400-700m<sup>3</sup>. A similar calculation for the volume of sheen yields 90% of 14  $\times$  0.1 which is equivalent to approximately 1.3m<sup>3</sup> of oil.

This example also serves to demonstrate that although sheen may cover a relatively large area of sea surface it makes a negligible contribution to the volume of oil present. Hence, it is crucial that the observer is able to distinguish between sheen and thicker oil.

---

THE INTERNATIONAL TANKER OWNERS POLLUTION FEDERATION LIMITED was established in 1968 to administer the Tanker Owners Voluntary Agreement concerning Liability for Oil Pollution (TOVALOP). The Federation is actively involved in all aspects of combating oil spills in the marine environment and provides technical advice on contingency planning, clean-up measures and environmental effects. It is also a comprehensive information source. This Technical Information Paper is one of a series based on the experience of the Federation's technical staff.

For further information contact:

INTERNATIONAL TANKER OWNERS POLLUTION FEDERATION LTD.,  
Staple Hall, Stonehouse Court, 87-90 Houndsditch, London, EC3A 7AX.  
Telephone: 01-621 1255 Telex: 887514



## USE OF BOOMS IN COMBATING OIL POLLUTION

### Introduction

When oil is spilt on the sea surface its removal or deflection from sensitive areas is often required. Both operations call for use of floating barriers or booms. The limitations of booms are seldom appreciated and the problems caused by the spreading of floating oil and by currents, tides, wind and waves are usually underestimated. Whilst these problems can on occasions be over-

come by effective design and proper deployment it must be appreciated that there is no universal approach that satisfies all situations and on some occasions the use of any boom will be inappropriate.

This paper describes the design of booms and their two main modes of operation, namely towing by vessels at sea and mooring in shallow or inshore waters, to contain or deflect oil.



1. Curtain boom used to contain oil released by shoreline clean-up.

### Design principles

Boom designs vary considerably (Fig. 1) but all normally incorporate the following features:

1. freeboard to prevent or reduce splashover;
2. sub-surface skirt to prevent or reduce escape of oil under the boom;
3. flotation by air or some buoyant material;
4. longitudinal tension member (chain or wire) to withstand effects of winds, waves and currents.

Boom designs fall into two broad categories:

**CURTAIN BOOMS** providing a continuous sub-surface skirt or flexible screen supported by a flotation chamber usually of circular cross-section;

**FENCE BOOMS** of flatter cross-section held vertically in the water by integral buoyancy.

Many designs include bracing struts and/or integral ballast to keep them vertical in the water,

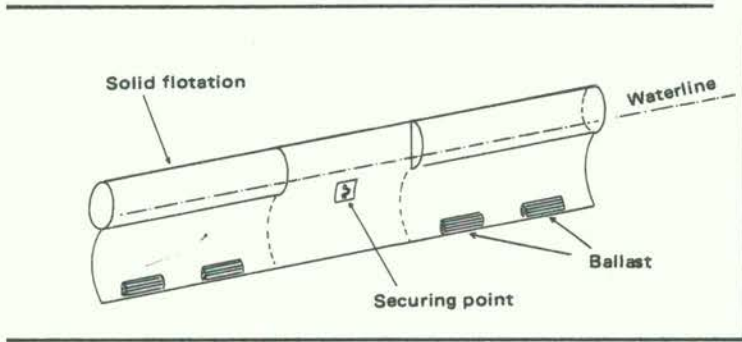
couplings for joining sections together as well as towing and anchoring points.

The most important characteristic of a boom is its oil containment or deflection capability, determined by its behaviour in relation to water movement. It should be flexible to conform to wave motion yet sufficiently rigid to retain as much oil as possible. No boom is capable of containing oil against water velocities much in excess of 1 knot (0.5 metres per second) acting at right angles to it. In fact the escape velocity for most booms is around 0.7 knots (0.35 m/s), irrespective of skirt depth. The importance of wind and waves in generating water velocities in excess of the escape velocity should be recognised. Oil escape can also be induced by turbulence along a boom and therefore a uniform profile without projections is desirable.

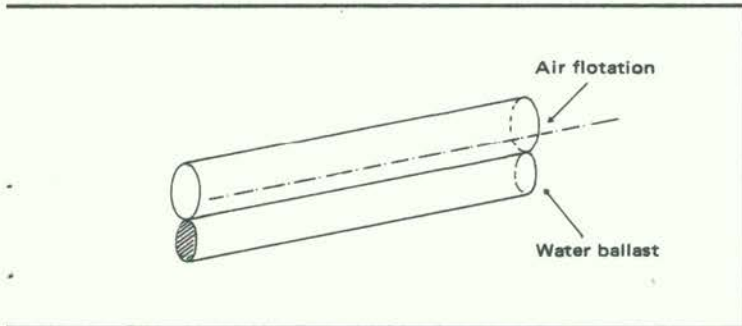
The size and length of boom sections are also



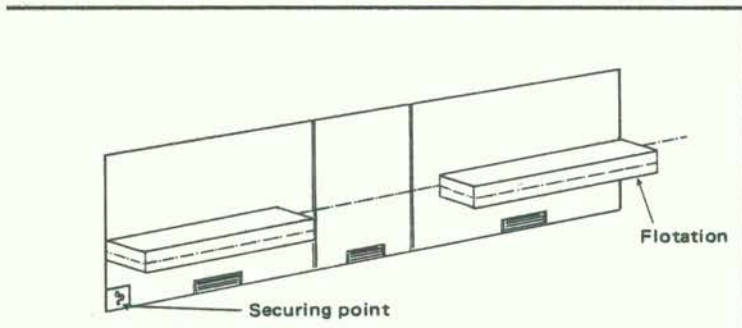
**Figure 1. SOME TYPICAL BOOM DESIGNS**



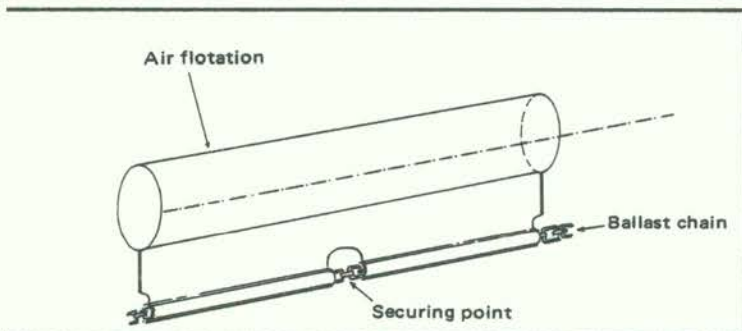
*A curtain boom with mooring points attached at intervals along its length at the waterline. Low oil escape velocity. Easily deployed and cleaned, resistant to damage by debris, reasonable surface following ability. Bulky in storage. Preference moored.*



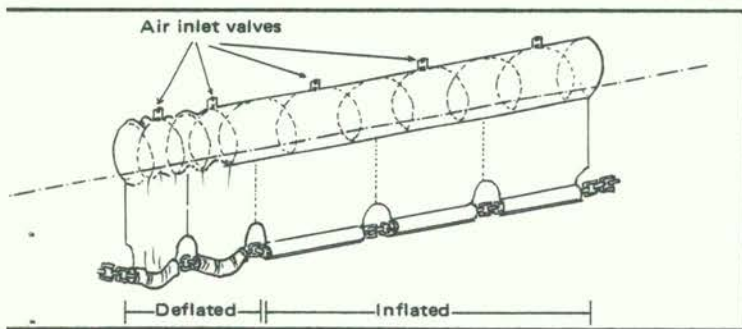
*Air flotation boom supporting a water-filled tube as a skirt. No integral mooring points but waterline towing pennants at either end. Moderate escape velocity and excellent surface following ability. Deployment and cleaning easy but susceptible to damage and sinking due to fabrication as a continuous length. Low volume storage. Preference towed.*



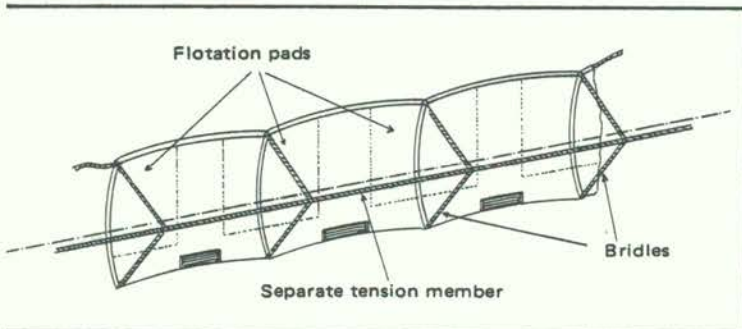
*Fence boom with mooring points at intervals along its length at the bottom. Fairly low escape velocity due to turbulence caused by the intermittent floats. Average surface following ability. Easy to deploy, resistant to damage, difficult to clean. Bulky in storage. Preference moored.*



*A curtain boom with a combined ballast and tension chain fitted in an integral pocket attached to bottom of skirt. Mooring points at intervals along the bottom. Moderate escape velocity. Good surface following ability. Easy to deploy and clean. Prone to damage by debris. Low volume storage when deflated. Preference moored.*



*Curtain boom with self-inflating air tube and combined ballast and tension chain fitted in a pocket attached to bottom of skirt. Mooring points at intervals along the bottom. Internal former to maintain shape. Moderate escape velocity. Good surface following ability. Rapid deployment capability. Cleaning difficult. Prone to damage of internal structure and ingress of water through air valves. Low volume storage. Preference moored.*



*A fence boom with mooring/towing points from end of separate tension member, which is attached to boom by short bridles. High escape velocity. Good surface following ability. Difficult to deploy because of complexity of rigging, difficult to clean. Reasonably resistant to damage. Moderate volume storage. Low weight. Preference towed.*



important considerations. The optimum size of boom is largely related to the sea state under which it is to be used. As a general rule, the minimum height of freeboard to prevent oil splashover should be selected. The depth of skirt should be of similar dimensions. While short section lengths can make booms easier to handle and can protect the integrity of the boom as a whole should one section fail, these advantages must be weighed against the difficulty of connecting sections effectively. Connections interrupt the boom profile and, wherever possible, should not coincide with the point of heaviest oil concentrations. The design of connectors should allow easy fastening and unfastening during deployment and with the boom in the water.

Other important characteristics are strength, ease and speed of deployment, reliability, weight and cost. It is essential that a boom is sufficiently robust for its intended purpose and will tolerate inexperienced handling, since trained personnel are not always available. Strength is required particularly to withstand the forces of water and wind on a boom when it is either towed or moored. Ease and speed of deployment combined with reliability are clearly very important in a rapidly changing situation and may strongly influence the choice made.

#### Forces exerted on booms

To estimate the approximate force  $F$  (kg) exerted on a boom with a sub-surface area  $A$  ( $m^2$ ) by a current with velocity  $V$  (knots) the following formula can be used:

$$F = 26 \times A \times V^2$$

Thus, the force acting on a 100 m length of boom with a 0.6 m skirt in a 0.5 knot water flow would be

$$F = 26 \times (0.6 \times 100) \times (0.5)^2 = 390 \text{ kg (force)}$$

It can be seen that doubling the current velocity would entail a four-fold increase in load.

The force exerted by wind directly on the freeboard of the boom (windage) can also be considerable. For the purpose of estimating the windage the above formula can be used on the basis that roughly equivalent pressures are created by a water current and a wind speed 40 times greater. For example, the force on a 100-metre length of boom with a 0.5 metre freeboard in a 15 knot wind would be:

$$F = 26 \times (0.5 \times 100) \times \left(\frac{15}{40}\right)^2 = 183 \text{ kg (force)}$$

In the above examples the combined forces of current and wind would be 573 kg if they were acting in the same direction on a rigid barrier. In practice the boom would be positioned at an angle to the flow forming a curve, thereby modifying the magnitude and direction of the forces. However, these calculations provide a guide to the forces and are an aid to the selection of moorings or towing vessels. When a boom is towed, its velocity through the water should be entered as  $V$  in the formula set out in the beginning of this section.

#### Towed booms

The rapid spread of oil spilt at sea over a large area poses the most serious problem in attempting to tow booms to contain floating oil. This, combined with limitations on boom performance is such that containment and collection techniques on the open sea will, in most cases, be only partially successful.

In an effort to prevent spreading and maximise encounter rate, long booms of 300 metres or more in U, V or J configuration may be towed using two vessels. The collection device is either towed with the boom array or deployed from a third vessel behind the boom (Fig. 2). The most effective designs incorporate tension members separated from the boom fabric by means of either an array of bridles or a section of netting beneath the skirt (separate tension booms). These arrangements encourage the boom to remain vertical under tow and leave it free to accommodate wave motion. In contrast, booms tensioned at their midpoint or waterline have a tendency to skim along the water surface.

When towing a sectioned boom in a 'U' configuration an odd number of sections of boom should be used to prevent having a join in the centre of the boom from which oil can more easily escape. To avoid sharp strain or snatching on a towed boom, lines of sufficient length between boom ends and the vessel should be used. Lines of 50 metres or more would be appropriate for towing a 300 metre length of boom.

Boom performance can be judged at the apex of the 'U' or 'J' by observing several factors. Oil lost under the boom will appear as globules or droplets rising 2-10m behind the boom. Sheens will be present despite good boom performance. Vortex formations behind the boom imply that it is being towed too fast.

Specialised vessels are required to maintain both the correct configuration of the towed booms and the desired very low speeds through the water, i.e. less than the escape velocity. Not only will each of the two towing vessels need at least half the total power required to tow the boom at the maximum speed consistent with oil retention, but also maximum manoeuvrability at slow speeds. As a guide each rated horse-power of an inboard engine corresponds to the ability to provide a pull of 20 kg force. Twin propulsion units, bow and stern thrusters and variable pitch propellers are valuable. In addition, an open and low aft deck working area with winch and lifting gear are necessary when handling bulky and heavy booms. The ideal towing point aboard the vessel will also need to be found by experiment and may need to be altered according to the course and wind direction. For example, a single screw vessel towing from the stern will be very unmanoeuvrable and towing from the pivoting point of the ship is preferable.

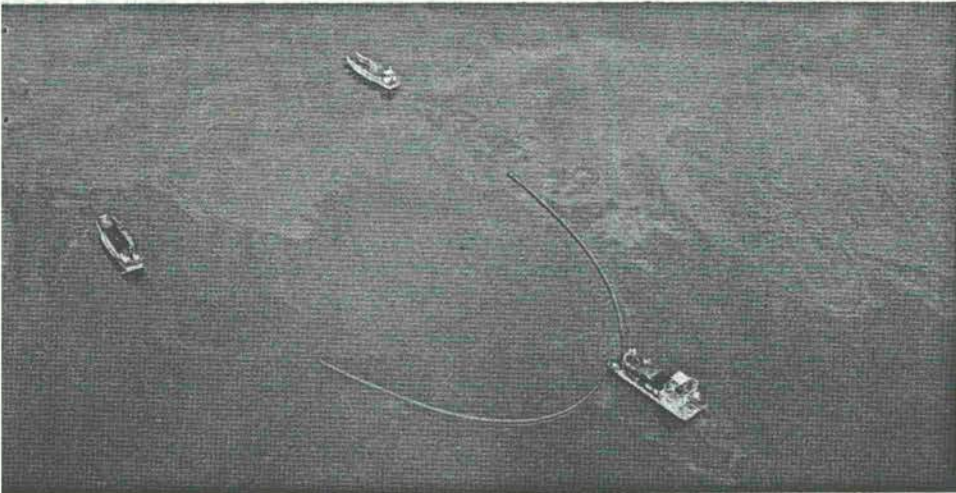
A single vessel may perform the multiple roles of oil containment, collection, separation and storage. Either a flexible boom, a rigid sweeping arm or sorbent mop array can be used to contain and collect oil. This system is more flexible than the more complex multi-ship approach but the oil encounter width is limited, being similar to the



**OFFSHORE USE OF BOOMS**



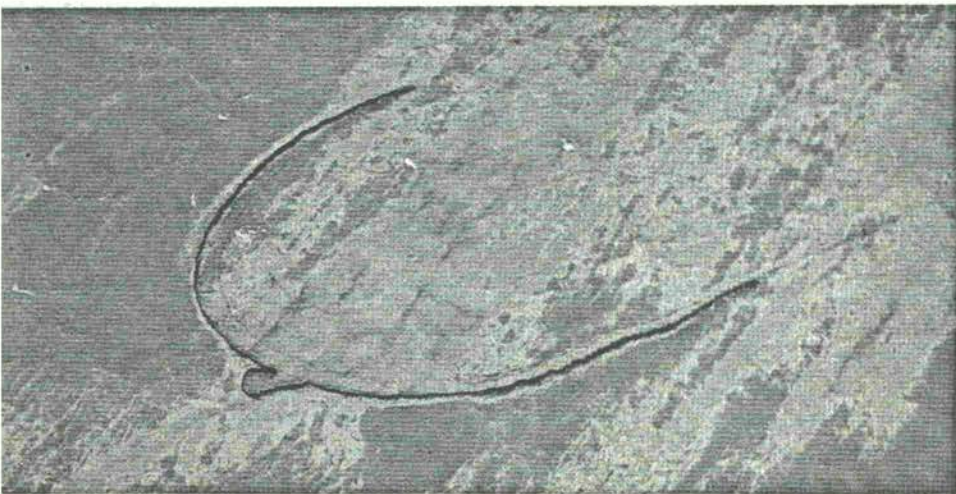
**2.** Single ship collection system employing a rigid boom deployed from small coastal tanker.



**3.** Self-inflating boom employed in V-configuration by two towing vessels with integral skimmer at apex.



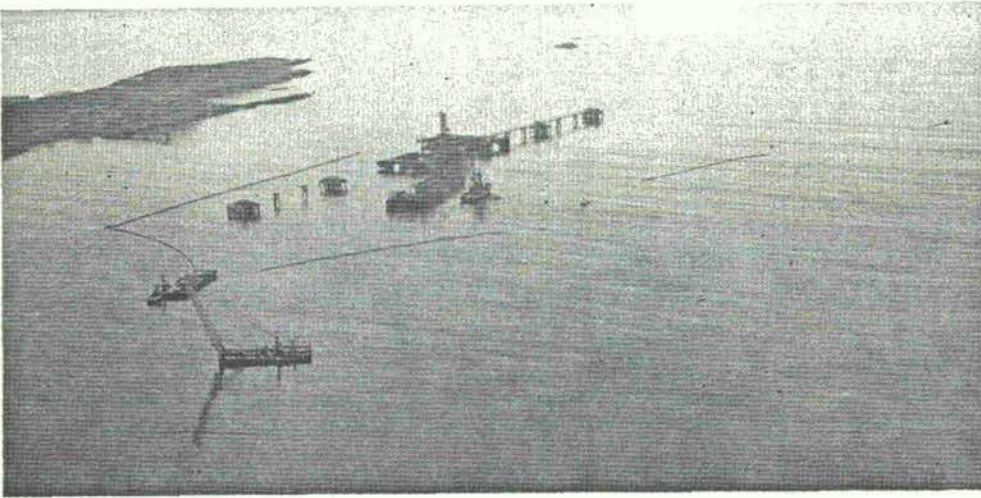
**4.** Separate tension boom under tow by two vessels with skimmer deployed from third vessel behind boom.



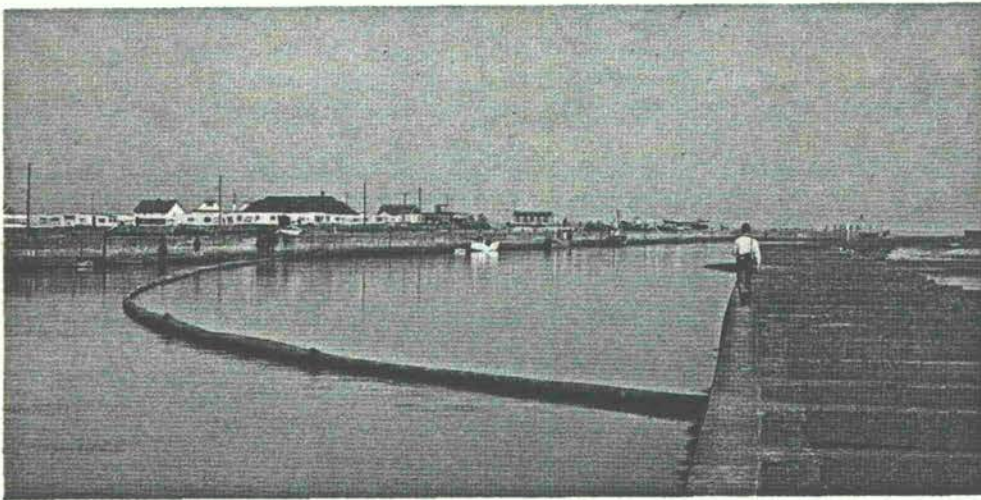
**5.** Separate tension boom collecting oil in 20 knot wind. Calculated wind-induced current is 3% of 20 knots = 0.6 knots (0.3 m/s).



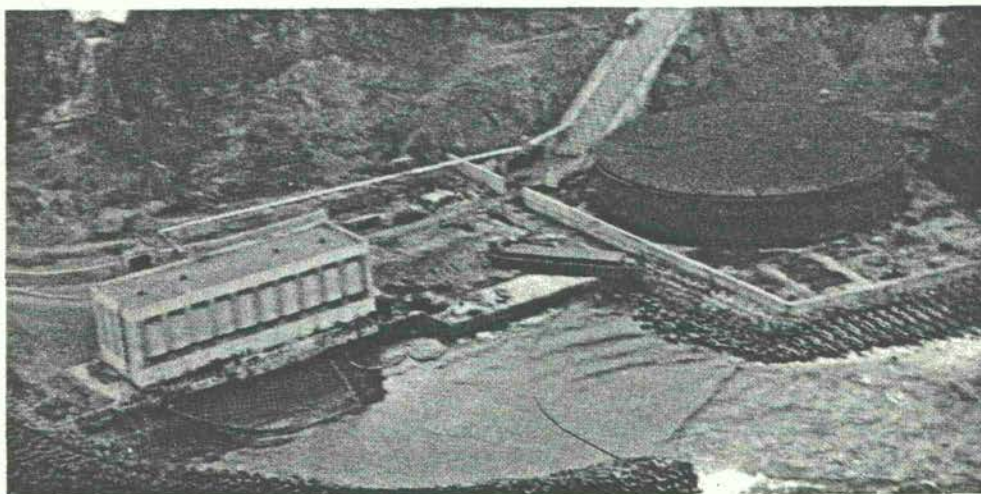
## INSHORE USE OF BOOMS



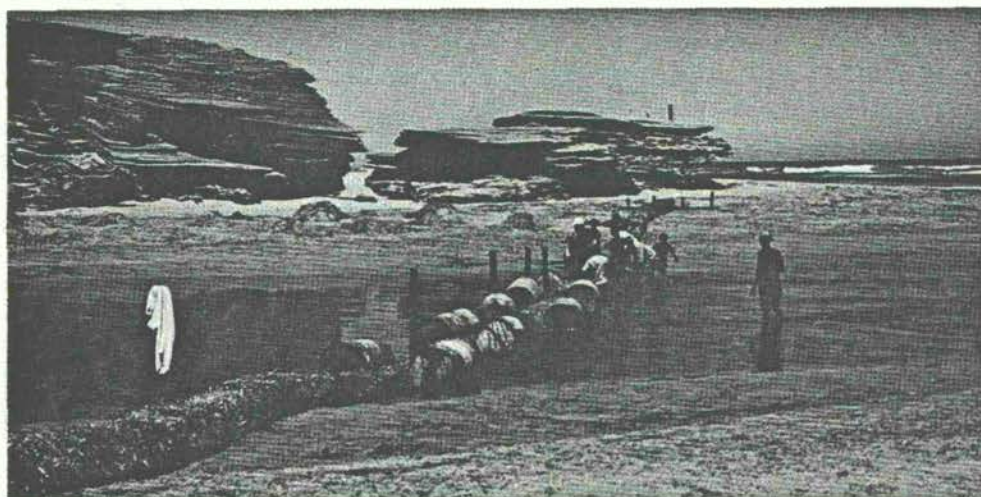
**6.** Curtain booms being positioned around sunken wreck during salvage operation.



**7.** Curtain boom deployed in deflection mode across an estuary.



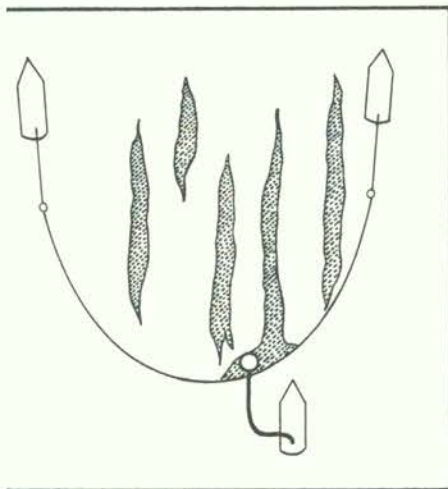
**8.** Breakwater acting as natural collecting point for oil. Fence boom deployed close to building to prevent oil entering power station cooling water intake.



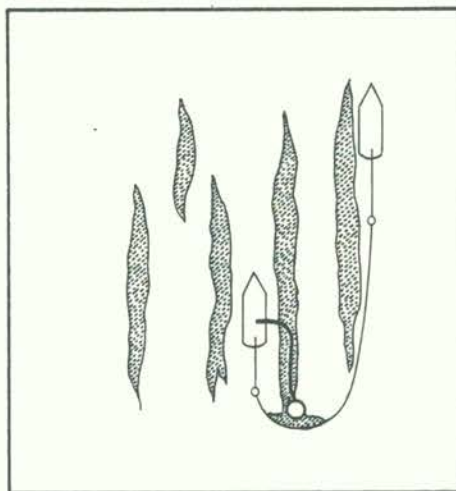
**9.** Improvised boom staked across small estuary, incorporating oil drums for flotation and straw bales as barrier/sorbent.



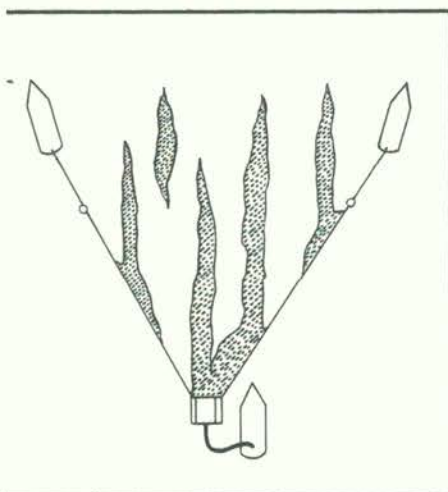
Figure 2. TOWED BOOM CONFIGURATIONS



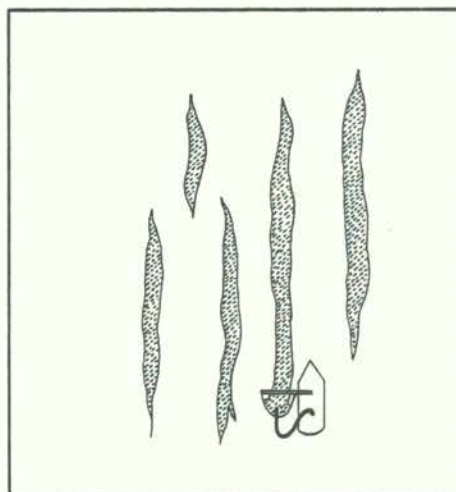
*U configuration towed by two vessels – collection device deployed from third vessel.*



*J configuration towed by two vessels one of which deploys collection device.*



*V configuration towed by two vessels – collection device towed with boom array and oil transferred to third vessel.*



*Single ship system incorporating containment and collection device.*

vessel's beam. This disadvantage may be less significant where floating oil is driven into narrow windrows.

### **Moored booms**

In exceptional circumstances it can prove practical to moor booms to contain spilled oil quite close to a source such as a leaking tanker or offshore oil well, but in many cases, particularly offshore, waters are too exposed and currents too strong or moored booms to be effective. Furthermore, the placing of booms close to the source may create a fire hazard and interfere with attempts to stem the flow of oil. In situations where the oil will dissipate naturally the use of booms is also inappropriate.

More frequently, booms are used close to shore or protecting particularly sensitive areas like estuaries, marshes, amenity areas and water intakes. In practice it may not be possible to protect all such sites. Careful planning should therefore be devoted to identifying first those which can be boomed effectively, and second, in order of priority. A further advantage of such planning is that preparations can be made for boom selection, mooring, and oil collection. Planning is particularly relevant for oil terminals and similar installations where both the source and most likely size of spill can be predicted.

An aerial survey can be valuable in identifying

suitable sites for using booms. In selecting the location and method of deployment it may be necessary to compromise between conflicting requirements. For instance, although it may be desirable to protect a complete river, the estuary may be too wide or the currents too strong to achieve this if there is appreciable tidal influence. A more suitable location may have to be sought further upstream, bearing in mind the need for access to deploy the boom and remove the collected oil. If the oil is not removed at the rate of its arrival at the inshore position, it will accumulate and move out towards the centre of the river where the stronger currents may sweep the oil under the boom. If current velocities are unknown they can be estimated by timing the movement of floating objects over a known distance.

It is frequently better to use booms to deflect oil to relatively quiet waters where it may be recovered rather than attempt containment. As shown in Table 1 it is feasible to deflect floating oil even in a 3 knot current (1.5 m/s) where a boom positioned at right angles to the flow would fail to contain any oil. Following this principle a river can be protected by placing a boom obliquely to the direction of flow. If it is necessary to maintain a navigation channel, two sections of boom can be staggered from opposite banks (Fig. 3).

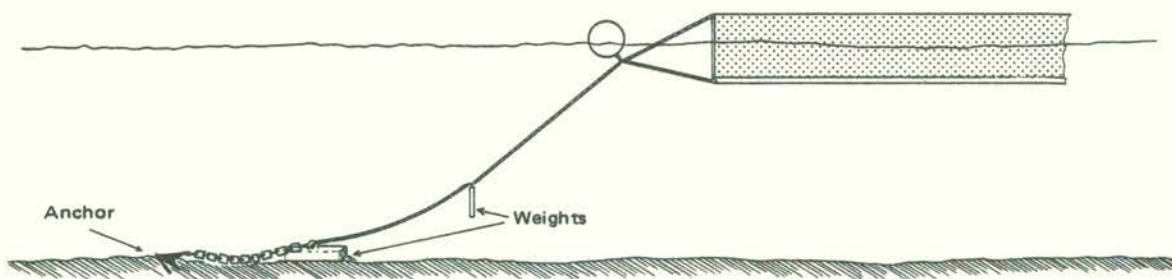


**Figure 3. STAGGERED BOOM CONFIGURATION ACROSS A CHANNEL**

Oil is lost from collection points when flow reverses



**Figure 4. TYPICAL MOORING ARRANGEMENT**



*Table 1. Maximum deployment angles to flow direction at different current strengths for bottom tension booms to prevent escape of oil. Calculations based on an escape velocity of 0.7 knots (0.35 m/s) at 90°.*

Current strength		Max. angle (degrees)
(knots)	(m/s)	
0.7	0.35	90
1.0	0.5	45
1.5	0.75	28
2.0	1.0	20
2.5	1.25	16
3.0	1.5	13

Correct mooring of the boom is crucial since performance is dependent upon the angle of deflection remaining appropriate to the prevailing current strength. To maintain this angle and prevent the formation of pockets, frequent anchoring points may be required. However, the laying of multiple moorings is often impractical in an emergency. The formula on page 3 can be used together with Tables 1 and 2 as a guide to the minimum size and number of moorings required to hold a boom in a current of known strength and taking the likely maximum wind effect into account. Whilst a Danforth type anchor is effective

on sand and mud substrates, a fisherman's type hook anchor is better on rocky bottoms. If time is available, concrete blocks can be cast to give convenient and reliable mooring points, but their weight in air must be at least three times the expected load, to compensate for their buoyancy in sea water. The use of a workboat with lifting gear would be required to handle heavy moorings.

*Table 2. Holding strength of Danforth type anchors in loose mud, sand or gravel, and clay.*

Anchor weight (kg)	Holding strength (kg force)		
	Mud	Sand	Clay
15	200	250	300
25	350	400	500
35	600	700	700

Whichever type of mooring is used, it is important to select the length of the mooring lines to suit the expected water depth, swell and tidal range. If the lines are too short the boom will not ride well in the water and the snatching produced in the lines by waves may dislodge the moorings. Conversely, if the lines are too long it will be difficult to control the configuration. A length of heavy chain or other weight between anchor and line greatly improves the holding power of an anchor,



and the use of an intermediate buoy between the boom and anchor will help prevent submersion of the end of the boom. Equally, a weight hung from the mooring lines stops them floating on the surface when slack. (Fig. 4). When deploying a boom out from a shoreline it is often possible to make use of fixed objects on the shore. On a featureless sandy beach a buried object such as a log provides an excellent mooring point.

As winds, currents and tides change, so will the configuration of a boom. Frequent checks and re-adjustment of the moorings will be necessary and contained oil and debris must be removed promptly since the performance and benefit of the boom will otherwise be severely reduced. In conditions where the air temperature is hot by day and cool by night it is important to allow for the expansion and contraction of air in inflatable booms. This may necessitate letting air out during the day and re-inflating at night. It should be recognised that booms are vulnerable to damage by passing vessels, particularly at night and it can be appropriate to take some precautions such as notifying mariners and displaying warning lights. Brightly coloured booms are more visible in daylight and are better picked out by lights at night.

Proper retrieval, maintenance and storage of a boom is important to prolong its useful life and ensure that it is always ready for use at short notice. Booms usually require cleaning after use and this can prove difficult for some designs (see Fig. 1). Dispersants or steam cleaning are usually employed but when using the former it is important to ensure that the boom fabric is compatible with such chemicals. Emergency repair kits should be kept on hand for dealing with minor damage which could otherwise make a section or even the whole length of boom unusable.

As well as using booms to intercept or deflect oil they can be used in sheltered areas where oil has collected naturally to prevent it moving should conditions change. This not only minimises the extent of the contamination but permits the controlled removal of the trapped oil. Booms can also assist shoreline clean-up by containing oil washed off beaches and rocks. By drawing in the boom the oil can be concentrated and be moved towards collection devices. In some circumstances, simple expendable sorbent booms can be used to collect thin oil films.

When purpose-built equipment is unavailable, it is possible to collect oil successfully with improvised booms made with locally available materials. For instance, floating booms can be made out of wood, oil drums, inflated fire hoses, rubber tyres or fishing nets filled with straw. In shallow waters stakes may be driven into the bottom to support screens or mats made from sacking, reeds, bamboo or other such materials. On long sandy beaches, sand bars can be built out into shallow water with bulldozers to intercept oil moving along the shoreline. A similar approach can sometimes be used to prevent the oil entering narrow estuaries or lagoons. However, such measures should be regarded as temporary and viewed with caution in view of the possibility of damage to the beach structure or ecology.

### Points to remember

1. Determine priorities for protection.
2. Decide whether selected areas are to be protected by either towed or moored booms.
3. Obtain as much information as possible on currents, tides and winds.
4. Calculate forces likely to be exerted on booms.
5. Select suitable points for mooring or means for towing.
6. Consider reliability, ease, speed of deployment and arrangements for suitable storage, maintenance and repair.
7. Review designs available and select booms that best meet the needs.
8. Thoroughly train personnel and maintain their standards by practical exercises.
9. Appreciate the limitations of booms in containing oil and be prepared to improvise when the need arises.

---

THE INTERNATIONAL TANKER OWNERS POLLUTION FEDERATION LIMITED was established in 1968 to administer the Tanker Owners Voluntary Agreement concerning Liability for Oil Pollution (TOVALOP). The Federation is actively involved in all aspects of combating oil spills in the marine environment and provides technical advice on contingency planning, clean-up measures and environmental effects. It is also a comprehensive information source. This Technical Information Paper is one of a series based on the experience of the Federation's technical staff.

For further information contact:

INTERNATIONAL TANKER OWNERS POLLUTION FEDERATION LTD.,  
Staple Hall, Stonehouse Court, 87-90 Houndsditch, London, EC3A 7AX.  
Telephone: 01-621 1255 Telex: 887514



## AERIAL APPLICATION OF OIL SPILL DISPERSANTS

### Introduction

The application of chemical dispersants is often an effective means of treating oil spills at sea. Rapid application techniques are necessary, however, as changes in the physical properties of spilled oil rapidly render dispersants ineffective. Spraying from surface vessels is an established method for applying dispersants but has several disadvantages, the most significant of which are the low treatment rate and poor surveillance capability making it difficult to locate concentrations of oil posing the most significant threat.

In recent years the development of effective concentrate dispersants has improved the potential for using aircraft in this role. Apart from the advantages of rapid response and high treatment rate, the correct use of aircraft ensures the optimum and most cost-effective use of dispersant.

This paper describes the aerial spraying technique and the types of equipment and aircraft available for such operations. Dispersants and their use in general are to be the subject of a separate paper in the series.

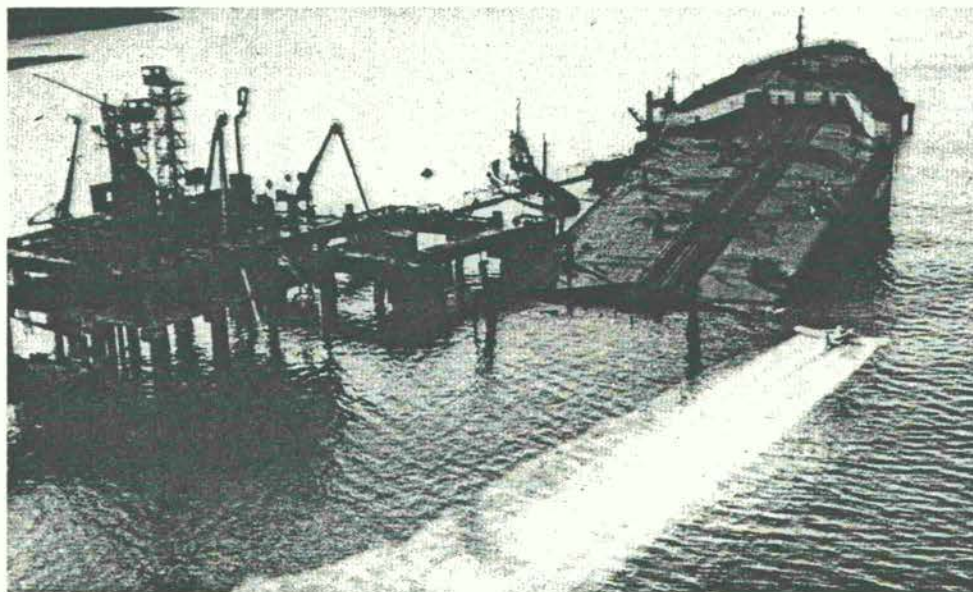


Figure 1. Piper Pawnee applying dispersant onto freshly released crude oil close to the shore.

### Aircraft type

Helicopters as well as single and multi-engined fixed wing aircraft have all been used successfully for the aerial spraying of dispersants. For an aircraft to be suitable, it should be capable of operating at low altitude and relatively low speeds, within the range 50-150 knots, exhibit good manoeuvrability and carry the highest possible payload for a particular aircraft size.

Aircraft used for spraying fall into two categories: those designed specifically for agricultural or pest control spraying operations, and those which have been converted (see table). Aircraft of the first type tend to be single-engined machines with small payloads such as the Piper Pawnee and the Cessna Agrtruck. The second

group includes multi-engined aircraft which vary in size from the Piper Aztec to the Douglas DC6. Whilst several different types of aircraft have been converted for spraying, few of each type exist due to the limited requirement for such aircraft in the past and the high costs involved in converting them to standards laid down by aviation licensing authorities. Several types of helicopter have also been converted for spraying. However, most helicopters are able to carry underslung loads and can therefore be equipped with a 'bucket' spray system without the need for modifications.

The optimum aircraft for a particular operation will be determined primarily by the size and location of the spill, although in reality availability will be the crucial factor. In the event of a major



**Table CHARACTERISTICS OF TYPICAL AIRCRAFT SUITABLE FOR AERIAL SPRAYING OF DISPERSANT**

<i>Aircraft Type</i>	<i>Propulsion</i>	<i>Dispersant tank capacity (litres)</i>	<i>Transit speed (knots)</i>	<i>Minimum runway length (metres)</i>
<b>Purpose-built single-engined agricultural aircraft</b>				
Aerospace Fletcher Cresco	Turbine	1530	140	300
Aerospace Fletcher	Piston	1045	115	245
Antanov An 2 R	Piston	1400	100	150
Basant	Piston	900	100	215
Cessna Agtruck	Piston	1060	100	400
Desmond Norman Fieldmaster	Piston	2640	145	175
EBM 701 Ipanema	Piston	680	105	465
IAR-822	Piston	600	80	300
Pilatus Porter PC-6	Turbine	950	110	180
Piper Brave 300	Piston	850	125	295
Piper Pawnee D	Piston	570	90	245
PZL Dromader M18	Piston	2500	100	250
PZL 106A Kruk	Piston	1400	90	220
Super AgCat B	Piston	1135	100	180
Thrush Commander	Piston	1365	100	300
Turbo Thrush	Turbine	2275	125	250
Transavia Air Truk	Piston	820	95	335
<b>Converted single &amp; multi-engined aircraft</b>				
<b>Helicopters (fuselage mounted)</b>				
Aérospatiale Lama	1 turbine	1140	80	—
Aérospatiale AS 350	1 turbine	1100	120	—
Bell 47	1 piston	400	75	—
Bell 206	1 turbine	680	115	—
Bell 212	2 turbine	1515	125	—
Hiller UH-12E	1 piston	500	80	—
Hughes 500	1 turbine	680	115	—
Enstrom F-28C	1 piston	400	70	—
<b>Fixed wing</b>				
Beech Baron	2 piston	450	200	410
BN Islander	2 piston	480	140	170
BN Trislander	3 piston	1250	145	395
Canadair CL 215	2 piston	5300	160	915
DC3	2 piston	4600	130	1000
DC4	4 piston	9460	190	1525
DC6	4 piston	13250	210	1525
Grumman Avenger	1 piston	2000	200	915
Piper Aztec	2 piston	570	175	300
Shorts Sky Van	2 turbine	1200	170	510
Twin Otter	2 turbine	2100	170	320
Volpar Turbo Beech 18	2 turbine	1100	220	510



spill, payload considerations alone could dictate the use of large multi-engined aircraft. For example, a spill of 4000 tonnes of crude may require the application of about 200 tonnes of dispersant within 24 hours (12 hours daylight). This could be achieved using one DC6. The simultaneous operation of 10 Piper Aztecs or 20 Piper Pawnees to provide equivalent treatment capability would present practical difficulties.

Small fixed wing aircraft with high endurance, lower fuel consumption, rapid turn round times and an ability to operate from short and even improvised landing strips are often the most suitable for small spills or fragmented slicks close to shore (Fig. 1). However, single-engined aircraft will always be restricted by the distance they can operate safely from the coast. The ability of helicopters to spray in confined situations and operate from a base very near to the spill site is often valuable. The facility to use them in other roles (e.g. rapid transport of personnel and equipment to inaccessible shore clean-up locations) can be an added advantage.

Although larger multi-engined aircraft (Fig. 2) offer the required range, payload, speed and safety for the treatment of large spills far offshore, it must be borne in mind that they need longer runways and greater operational support, have longer turn round times and more restricted visibility and manoeuvrability. Sufficient quantities of the appropriate grade of fuel may be difficult or even impossible to obtain in some parts of the world. This is true for aviation gasoline (Avgas) used to fuel piston engines and in these areas the choice of aircraft is limited to those fitted with turbine engines, which use Avtur.

### **Spraying systems**

Figure 3 shows the typical components of a system for a small fixed wing aircraft. A wind-driven pump draws chemical at a controlled rate from one or more tanks to feed the spray booms which are usually fitted close to the trailing edge or above the wing. The chemical is discharged through units spaced at intervals along the boom which generate droplets within a preferred size range.

Whilst spraying equipment on helicopters is often similar to that fitted to fixed wing aircraft they have the alternative facility of carrying a combined tank, pump and spray boom assembly suspended some distance below the fuselage by wire strops with a quick coupling mechanism, (Fig. 4). By using two such 'bucket' spray units alternately, turn round times can be reduced. Whilst these also have the advantage that the spray pattern is less likely to be affected by the rotor down draught, it is more difficult to maintain the necessary low altitude when using an under-slung system unless a short strop length is used. However, the strop must be at least 1.5 m (5 ft) long to allow sufficient room for the 'bucket' to be disconnected in safety.

The devices used to control drop size fall into two main categories (see diagram on page 6) :

*Pressure nozzles:* (e.g. Spraying Systems Tee-Jet, Delavan 'Raindrop' nozzle). Nozzles are fitted at intervals along a spray boom.

*Rotary devices:* (e.g. Micronair Rotary Atomiser) usually a wind-driven rotating cylindrical gauze through which the chemical is pumped forming droplets of the required size range. These are more widely spaced and mounted either on a spray boom or special brackets.

Both pressure nozzles and rotary atomisers are used on helicopters, single-engined crop spraying aircraft and on the smaller twin-engined aircraft. Pressure nozzles are also used on larger aircraft such as the Douglas DC4 and DC6 because the rotary devices are not considered suitable for these aircraft due to the large number of units that would be required to give the necessary throughput.

Although dispersant spraying is in many ways similar to agricultural chemical spraying, it differs in two respects: application rates tend to be higher (typically 100 litres/hectare, 10 imp. gal/acre) and drop sizes larger (600-800 micrometres ( $\mu\text{m}$ )), the latter to minimise wind drift and possible evaporative losses.

Apart from the Delavan 'Raindrop' nozzles the above devices were originally designed to produce the small droplets required for agricultural spraying. However, they can be quickly and easily modified to produce larger droplets. In the case of 'Tee-Jet' nozzles, the swirl plate should be removed and an orifice plate selected to give an opening of about 5 mm. In addition, the nozzles should be oriented parallel to the airflow and pointed aft. The rubber diaphragms fitted to the 'Tee-Jet' nozzles to prevent loss of dispersant when the pump is switched off deteriorate rapidly in contact with dispersant and need to be replaced frequently. Alternative materials, resistant to dispersant are available. Modification of the Micronair units involves the installation of a  $3\frac{1}{2}$ " 10 mesh coarse cylindrical gauze. It is also necessary to slow down the rotation speed by feathering the fan blades to about 70 degrees for the standard  $11\frac{1}{2}$ " diameter blades.

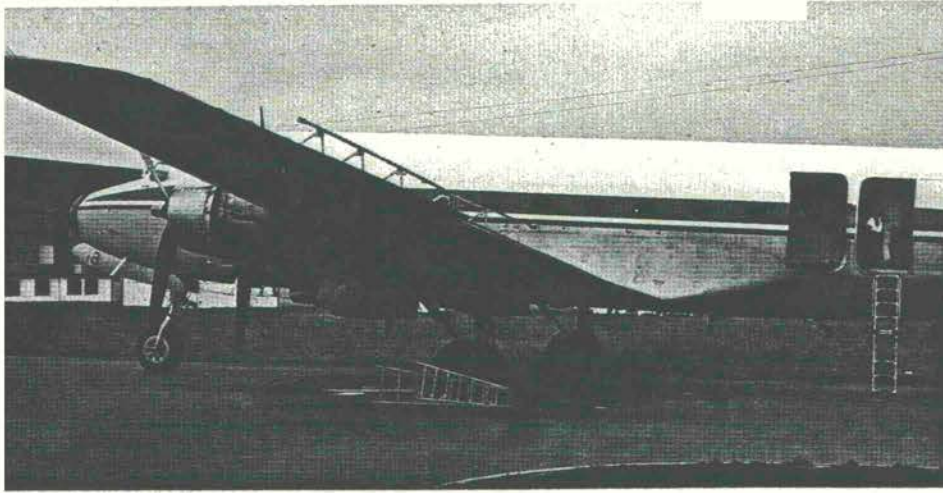
Spraying equipment is prone to blockage, particularly with some dispersants which can form a gel with small quantities of water. The nozzles should therefore be inspected regularly.

### **Application rates**

Only concentrate dispersants applied neat are suitable for aerial spraying, since they require no additional mixing beyond that provided by the natural movement of the sea. They also make the best use of available payload. For most concentrates, the ratio of dispersant to oil required for effective dispersal varies between 1:5 and 1:30 depending upon the type of oil and prevailing conditions.

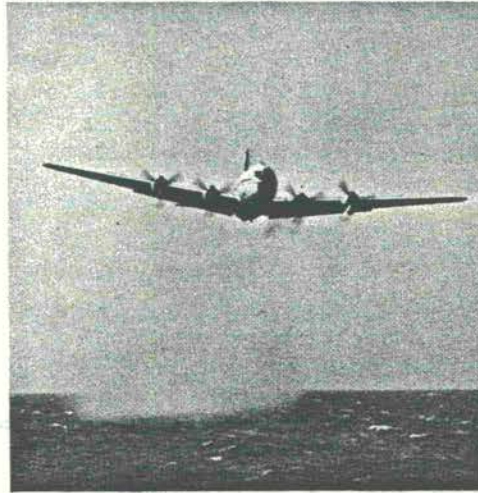
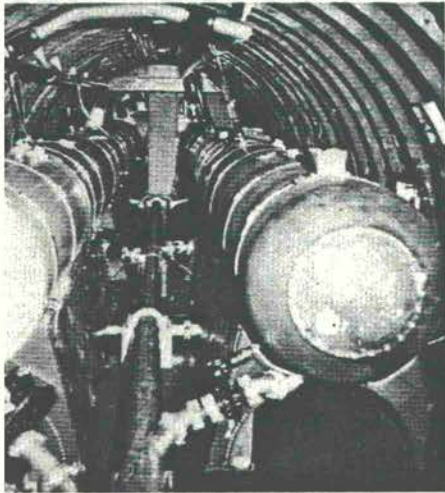
In order to calculate the application rate (in litres/hectare), the average thickness of the floating oil must be assessed. As a general rule, most liquid oils on the sea surface will spread to





**Figure 2. Large Multi-engine Aircraft**

DC4 with spray booms mounted above wings.



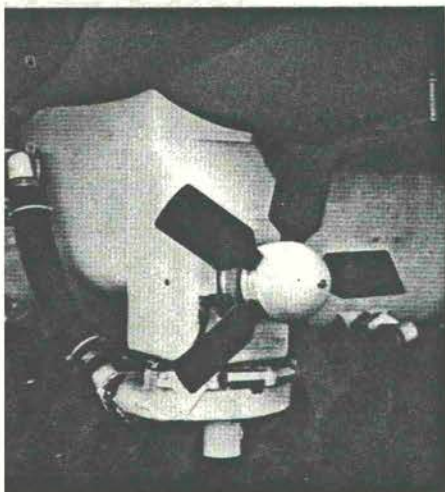
*Left* – Dispersant tanks inside a DC6.

*Right* – DC4 spraying dispersant.

**Figure 3. Typical components of a spraying system fitted to a Piper Aztec.**



Underslung belly tank.



*Left* – Wind driven pump.

*Right* – Spray boom and nozzles.





**Figure 4. Helicopter bucket spray systems.**

Bucket spray system operated from an Aérospatiale Dauphin 2.



*Left* – Bucket, spray boom and pump assembly.

*Right* – Coupling bucket to a Bolkow 105.

**Figure 5. Typical spraying aircraft.**



Enstrom F-28C crop spraying helicopter.

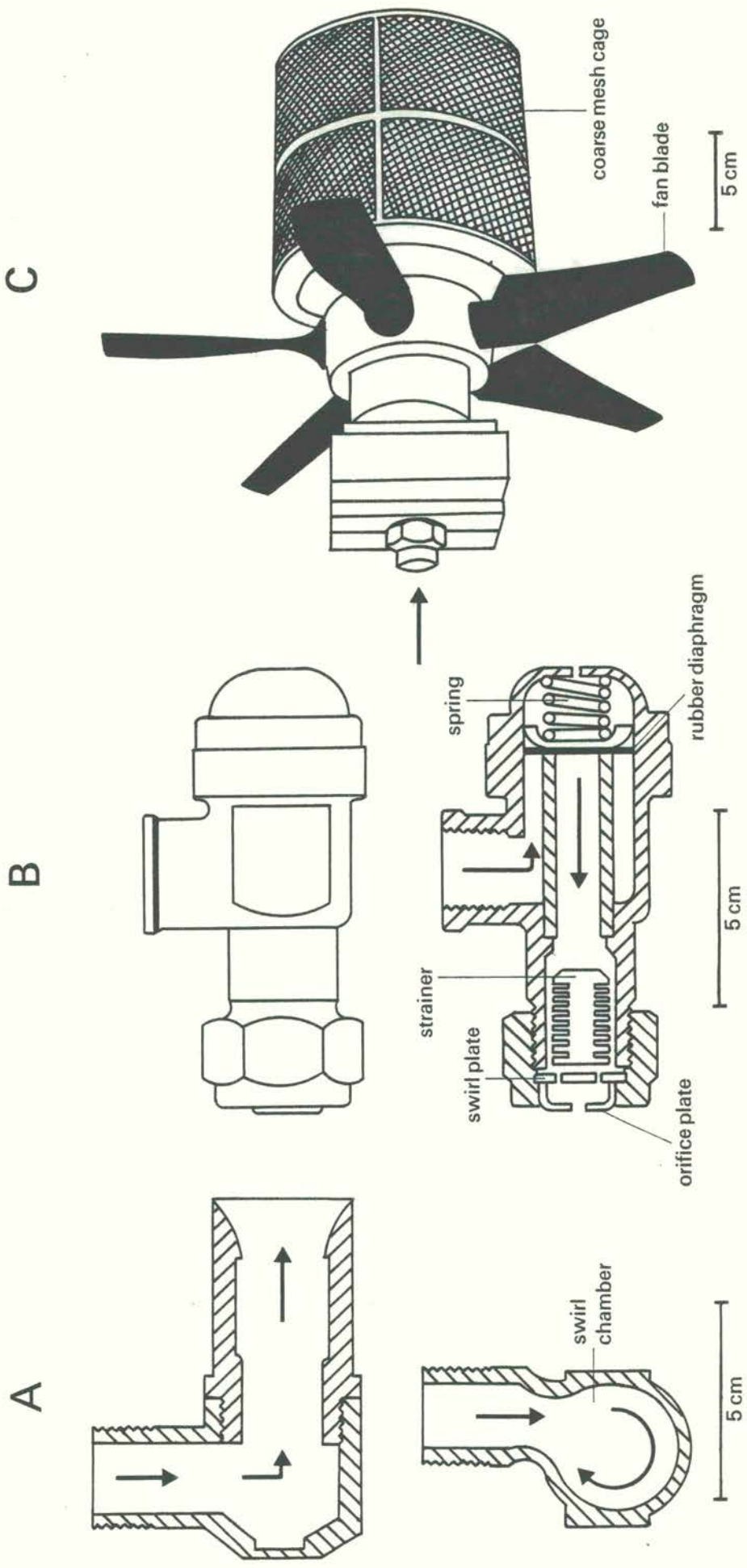


*Left* – Canadair CL 125 firefighting aircraft.



*Right* – Piper Pawnee crop spraying aircraft.





*Spray nozzles. Simplified diagram showing operating principles and directions of dispersant flow.*  
**A.** Delavan "Raindrop" nozzle type RA featuring tangential entry of fluid to swirl chamber. **B.** Spraying Systems "Tee-Jet" nozzle. To obtain large droplets the strainer, swirl plate and on larger aircraft also the orifice plate should be removed. **C.** Micronair Rotary Atomizer fitted with variable pitch fan blades and 5-inch cage containing fluid distributor. To obtain large droplets, a smaller 3½-inch cage should be substituted.



reach an average thickness of 0.1 mm ( $10^{-4}$  metres) within a few hours. At this thickness the volume of oil in one hectare ( $10^4$  sq. metres) would be

$$10^{-4} \text{ m} \times 10^4 \text{ m}^2 = 1 \text{ m}^3 \text{ or } 1000 \text{ litres}$$

For a dose rate of 1:20, the appropriate application rate would then be 50 litres/hectare (5 imp. gal/acre).

With an effective swath width of 15 m, an aircraft flying at 90 knots over the sea (45 m/s) can apply dispersant at 50 litres/hectare ( $0.005 \text{ l/m}^2$ ) if dispersant is discharged at a rate calculated as follows:

$$\begin{array}{rcl} \text{application rate} \times \text{swath} \times \text{speed} & = & \text{discharge rate} \\ 0.005 & \times & 15 \quad 45 & = & 3.37 \text{ litre/sec} \\ & & & & \text{or } 202 \text{ litre/min (45 imp. gal/min)} \end{array}$$

Whilst application rates of the order of 50 litres/hectare have been found to be appropriate in many situations, adjustment is required to compensate for variations in thickness of the floating oil. Thick patches may call for an increase of the application rate or multiple application in order to achieve the required dosage. The application rate can be controlled in flight by varying aircraft speed and dispersant flow rate.

In calculating application rates an allowance must be made for losses of dispersant spray during its passage through the air to the sea surface. It is essential to reduce to a minimum those losses due to wind drift and air turbulence. Large droplets assist in this respect but in addition the aircraft should be flown as low as safety considerations allow. Typically an altitude of 5-15 m (16-50 feet) is used depending on the size of aircraft and the prevailing conditions. Because of the difficulty of judging height over the sea in the absence of familiar reference points, some aircraft, particularly the larger ones, are equipped with radio altimeters to assist the pilot to fly at these very low altitudes. Wind drift can be further limited by flying into the wind whilst spraying. This measure is frequently necessitated in any case by the tendency of floating oil to become aligned in the direction of the wind as narrow bands or windrows interspersed with zones of thin sheen or clean sea.

In order to assess dispersant losses and so establish the effective application rate for a particular combination of aircraft and spray system, it is advisable at the planning stage, to carry out calibration tests overland, simulating actual spray sorties. The effect on application rate of such factors as aircraft speed, height, wind speed and direction, swath, dispersant droplet size and dispersant flow rate should be examined. Such tests are conveniently carried out on an airfield where sampling cards are placed across the expected swath so that the application rate and droplet size distribution can be analysed. This procedure also provides an opportunity to optimise the position and interval between nozzles to identify the configuration that gives the most uniform pattern across the swath to compensate for such effects as propeller wash and wing tip vortices.

## Organisation and control

A knowledge of the physical properties of the spilled oil will provide an indication of the likelihood that dispersant treatment will be effective. If the oil has a pour point above or close to the sea temperature or if its viscosity is greater than about 2000 centipoise (that of medium fuel oil at  $10^\circ\text{C}$ ), it is improbable that it will disperse, although in marginal cases final judgement can only be reached on-site. Even when a fresh oil is judged dispersible by these criteria, exposure to the weather rapidly makes it resistant to dispersant treatment through evaporation and the formation of water-in-oil emulsions.

For this reason, an objective and continuous assessment must be made of the effectiveness of the dispersant to prevent wastage of costly chemical. This is not easy and observers should not be misled by the disappearance of thin films immediately after the dispersant has been applied or by a white plume caused by the dispersant itself. The best visual indication that the dispersant application has been successful is the rapid formation of a cloud of dispersed oil droplets in the water, but under some circumstances the oil may diffuse only slowly from the water surface. A more reliable evaluation can be achieved by observations over a period of time assisted by aerial photography or remote sensing techniques with 'instant' or rapid processing to check that the quantity of floating oil is actually being reduced.

To ensure that an operation is conducted both safely and effectively it is desirable to control and coordinate it from an additional aircraft overhead. This can be a light fixed wing aircraft or helicopter but it must have a high endurance and good communications both with the spray aircraft and ground control.

The control aircraft can be used in a number of roles. It can be used to identify the heaviest concentrations of oil or those slicks posing the greatest threat and to direct spray aircraft to them. During the spraying operation itself, it can be used to guide the spray aircraft on to the target and to judge the accuracy of the application and the effectiveness of the treatment. These functions are particularly important when large multi-engined aircraft are used for spraying because once these aircraft are at low altitude the crew have great difficulty in distinguishing between oil and sheen, especially if the slick is broken up. When using small spraying aircraft, all these tasks can be undertaken by the pilot provided he is experienced in the technique.

Control must be exercised over the operation to ensure the safety of the aircraft and crew. Relief crews may be called for as flying over the sea at very low altitude is extremely arduous. All the usual safety procedures must be observed despite difficult conditions. Regular checks are recommended to ensure that the dispersant does not contaminate lubricants, particularly in the tail rotor assembly of helicopters, or attack exposed rubber components of aircraft flight control systems. It is advisable to wash down the aircraft frequently



with fresh water to remove both dispersant and oil water spray. It should be noted that dispersant removes paint very effectively and may cause slight crazing of stressed Perspex used in windscreens and windows.

Good organisation on the ground is also needed to keep the aircraft over the oil for the maximum available time during daylight hours. This may require routine maintenance to be carried out at night. Supplies of aircraft fuel and dispersants must be maintained. While dispersants and fuel in drums will be adequate to support a small scale operation, a large aircraft would have to be supplied from road tankers using high capacity pumps.

### Contingency planning

Before a spill occurs a number of preparations should be made to ensure that the full potential of the technique is realised. Landing sites should be identified along the coast and consideration given to sources of supply for dispersant and fuel and

arrangements for transport. A policy for dispersant usage must be agreed so that in the event of an oil spill the locations and conditions under which dispersants can be used are already established.

Although locally available agricultural aircraft can be utilised for small spills it should be borne in mind that these may be difficult to obtain at certain times of the year. Major spills, particularly those further offshore, require larger aircraft and since these are usually not readily available it may be necessary to provide a dedicated response capability. Since this would involve the payment of a substantial retainer to ensure that aircraft are available to respond immediately, it is advantageous to find a compatible additional role for the aircraft. One such role might be firefighting which has many parallels with dispersant spraying. Alternatively, they might be used to monitor traffic separation schemes for shipping and to detect and identify vessels discharging oil illegally into the sea. Crew familiarity with both low flying over the sea and recognition of oil could be maintained in this way.

### Points to remember:

1. Aerial spraying has the advantages of rapid response, good surveillance, high treatment rates, optimum use of dispersant, and good evaluation of dispersant treatment.
2. Although capital and operating costs of aircraft are high, aerial spraying is often cost-effective compared with other clean-up techniques.
3. The recommended dose rate of dispersant to oil varies between 1:5 and 1:30 but a trial and error approach should be adopted in the field.
4. Dispersant should be applied as droplets with a mean diameter in the range 600-800  $\mu\text{m}$ , with the aircraft flying at the minimum safe altitude and into the wind.
5. Dispersant performance is limited by the viscosity of the oil or water-in-oil emulsion to be treated. Checks on dispersant effectiveness should be made throughout the operation.
6. Dedicated aircraft are recommended for high risk areas to ensure an immediate and sustained response.
7. Success depends upon positive control of the aircraft and ground support teams. This demands a comprehensive communications network.

---

THE INTERNATIONAL TANKER OWNERS POLLUTION FEDERATION LIMITED was established in 1968 to administer the Tankers' Voluntary Agreement concerning Liability for Oil Pollution (TOVALOP). The Federation is actively involved in all aspects of combating spills in the marine environment and provides technical advice on contingency planning, clean-up measures and environmental effects. It is a comprehensive information source. This Technical Information Paper is one of a series based on the experience of the Federation's technical staff.

For further information contact:

INTERNATIONAL TANKER OWNERS POLLUTION FEDERATION LTD.,  
Staple Hall, Stonehouse Court, 87-90 Houndsditch, London, EC3A 7AX.  
Telephone: 01-621 1255 Telex: 887514



## USE OF OIL SPILL DISPERSANTS

### Introduction

Chemical dispersants can sometimes be used to combat oil pollution by breaking up oil slicks into very small droplets. These become suspended in the water and are rapidly diluted by the turbulent motion of the sea. Dispersion of the oil into the water prevents the formation of persistent water-in-oil emulsions and residues which are difficult to clean up. In dispersed form the oil is available for degradation by micro-organisms which occur naturally in the sea.

Chemical dispersal at sea may provide the only means of removing the oil from the surface, thereby protecting resources in its path and preventing oil coming ashore particularly when containment and recovery are impractical. However, in common with all remedial measures, the use of dispersants has its limitations and should be subject to careful control. This paper explains how dispersants work; the types available; the methods of application at sea and on shorelines and the environmental considerations involved.



Figure 1. Warren Spring Laboratory designed spray booms and surface breaker boards being used from a tug.

### Mechanism of chemical dispersion

When a great deal of mixing energy is imparted directly to the oil-water interface the oil may disperse naturally. Such natural dispersion does in fact occur in moderately rough seas but the addition of dispersant accelerates this process.

The key component of a dispersant is a surface-active agent (surfactant) which has a molecular structure such that one part of the molecule has an affinity for oil (oleophile) and the other has an affinity for water (hydrophile). When evenly applied and mixed into floating oil the molecules become arranged at the oil-water interface with the result that the interfacial tension between oil and water is reduced favouring the formation of finely dispersed oil droplets with a combined surface area greater than the original oil slick. For

a fixed amount of mixing energy, a reduction in interfacial tension between oil and water will result in a corresponding increase in combined droplet area. The smaller the droplets, the greater the chance that they will remain suspended in the water because of their very slow rise velocity. In practice, for most black oils, provided the droplets produced have an average diameter of 0.2 mm they are unlikely to return to the sea surface except in calm conditions. However, in the case of refined oil products with low specific gravities, much smaller droplets are necessary to overcome their greater buoyancy. If an oil is satisfactorily dispersed (see Fig. 3), a characteristic plume can be seen to spread slowly down from the water surface a few minutes after treatment.

Apart from promoting droplet formation,



Table 1. Crude Oils with High Viscosities or High Pour Point

The pour point of an oil is the temperature below which the oil will not flow. The oils set in *blue type* are unlikely ever to be amenable to dispersants because of high viscosities or high pour points. The other oils listed could be amenable to dispersants when the ambient temperature is high. To determine viscosities at ambient temperatures, refer to Figure 4, Note 1.

Crude Name	Loading Port	Country	Gravity* °API	Viscosity cS 100°F 37.8°C	Pour point	
					°C	°F
Amna	Ras Lanuf	Libya	36.1	13	18	65
Arjuna	SBM	Indonesia, Java	37.7	3	27	80
Bachequero Medium	La Salina	Venezuela	17.0	350	-20	-5
Bachequero Heavy	La Salina	Venezuela	14.0	890	-18	0
Bahia	Salvador	Brazil	35.2	17	38	100
Bakr	Ras Gharib	Egypt	20.0	152	7	45
Bass Strait		Australia	46.0	2	15	60
Belayim (land)	Wadi Feiran	Egypt	21.6	95	4	40
Belayim (marine)	Wadi Feiran	Egypt	30.6	12	15	60
Boscan	Bajo Grande	Venezuela	10.3	19400	15	60
Bu Attifel	Zueitina	Libya	40.6	—	39	102
Bunju	Balikpapan	Indonesia, E. Kalimantan	32.2	not known	17.5	63
Cabinda	SPMB-Landana	Angola	32.9	20	27	80
Cinta	SBM	Indonesia, Sumatra	32.0	—	43	110
Cyrus	Kharg Island	Persian Gulf	19.0	520	-18	0
Duri	Dumai	Sumatra	20.6	100	14	57
El Morgan	Shaukeer	Egypt	32.3	9.5	7	45
Eocene	Mina Abdulla	Kuwait	18.6	175	-34	-30
Escravos	SBM	Nigeria	36.2	4	10	50
Es Sider	Es Sider	Libya	37.0	5.7	9	48
Gamba	SPMB-Gamba	Gabon	31.8	27	15	60
Gippsland Mix	Western Port Bay	Australia	44.4	2	15	60
Handil	SBM	Indonesia, E. Kalimantan	30.8	5870	35	95
Heavy Lake Mix	La Salina	Venezuela	17.4	600	-12	10
Iranian Nowruz	Bahrgan	Iran	18.3	270	-26	-15
Jatibarang	SBM	Indonesia, Java	28.9	—	43	110
Jobo Morichal (Monagas)	Puerto Ordaz	Venezuela	12.2	3780	-1	30
Lagunillas	La Salina	Venezuela	17.7	500	-20	-5
Mandji	Cap Lopez	Gabon	29.0	17	9	48
Meray	Puerta La Cruz	Venezuela	17.2	520	-23	-10
Minas	Dumai	Indonesia, Sumatra	35.2	—	32	90
Nigerian Light	Bonny	Nigeria	35.8	3	15	60
Panuco	Tampico	Mexico	12.8	4700	2	35
Pilon	Carpito	Venezuela	13.8	1900	-4	25
Qua Iboe	SBM	Nigeria	37.4	3.4	10	50
Quiriquire	Carpito	Venezuela	16.1	160	-29	-20
Ras Lanuf	Ras Lanuf	Libya	36.9	4	7	45
Rio Zulia	Santa Maria	Colombia	40.8	4	27	80
San Joachim	Puerto La Cruz	Venezuela	41.5	2	24	75
Santa Rosa	Puerto La Cruz	Venezuela	49.4	2	10	50
Sarir	Marra El Alariga	Libya	36.5	10	21	70
Seria	Lutong	Brunei	36.9	2	18	65
Taching	Darien	P.R., China	33.0	138	35	95
Tia Juana Heavy	La Salina	Venezuela	18.2	220	-37	-35
Tia Juana Pesada	Puerto Miranda	Venezuela	13.2	3470	-1	30
Trinidad	Point Galeota	Trinidad	33.6	3	14	57
Wafra Eocene	Mina Saud	Neutral Zone	23.3	271	-29	-20
Zaire		Zaire	34.0	12	15	60
Zeta North	Puerto La Cruz	Venezuela	35.0	3	21	70

141.5

$$\text{Specific Gravity} = \frac{141.5}{\text{API} + 131.5}$$



dispersants perform a secondary role by preventing coalescence of the oil droplets once they are formed. This is because the surface active agent remains at the oil water interface long enough to act as a barrier between droplets which may collide with one another at random.

The effective distribution of surfactant throughout the oil is very important and most dispersants therefore contain a suitable solvent system which penetrates the oil and acts as a carrier for the surfactant. However, if the oil is very viscous, dispersants are ineffective, since they tend to run off the oil into the water before the solvent can penetrate. As a general rule, dispersants are capable of dispersing most liquid oils and liquid water-in-oil emulsions with viscosities less than about 2000 centistokes, equivalent to a medium fuel oil at 10-20°C. They are not suitable for dealing with viscous emulsions (mousse) or oils which have a pour point near to or above that of the ambient temperature. Table 1 lists some crude oils which may not be amenable to dispersants due to their viscosity or pour point and Figure 4 gives some typical viscosity values for different oils at various temperatures. Even those oils which are initially dispersible, become resistant with weathering at sea because of increased viscosity. The time taken for evaporation and emulsification to render a particular oil resistant to dispersant depends upon such factors as sea state and temperature but in most cases it is unlikely to be longer than a day or two. Dispersants are sometimes more effective with viscous oils on shorelines because the contact time can be prolonged to allow penetration of the chemical into the oil layer.

### Types of dispersant

Dispersants in use today are of two main types :

- A. Hydrocarbon or conventional dispersants which are based on hydrocarbon solvents and contain between 15 and 25% surfactant. They are intended for neat application to oil and should not be pre-diluted with sea water since this renders them ineffective. Typical dose rates are between 1 :1 and 1 :3 (dispersant :oil).
- B. Concentrate or self-mix dispersants which are alcohol or glycol solvent based and usually contain a higher concentration of surfactant components. They can be applied either neat or pre-diluted with sea water. Typical dose rates are between 1 :5 and 1 :30 (neat dispersant :oil).

Hydrocarbon based dispersants and concentrates pre-diluted with sea water require thorough mixing with the oil after application to produce a satisfactory dispersion. However, concentrates, if sprayed undiluted directly on to the oil, do not require the same degree of mixing and usually the natural movement of the sea is sufficient to break up a treated slick into droplets. Concentrates have largely superseded hydrocarbon based dispersants for application at sea. The main reason for this is the lower application rates required with concentrates which increases the endurance of spraying craft.

### Methods of application

#### 1. At sea

The method of application depends primarily on the type of dispersant, the size and location of the spill, and the availability of vessels or aircraft for spraying the dispersant. Table 2 summarises the main characteristics of various dispersant spraying systems.

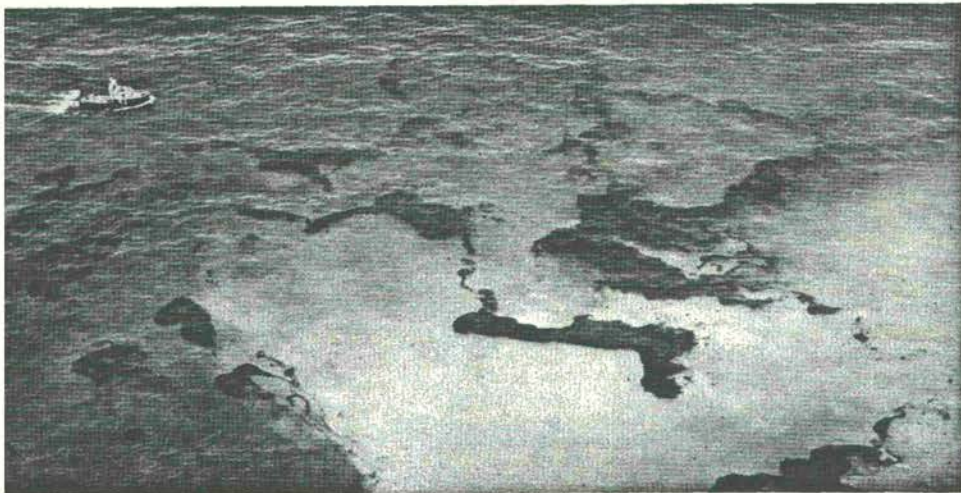
When specialised spraying equipment is not available, the fire pumps and hoses fitted to most vessels can be employed to achieve simultaneous application and mixing of concentrate dispersants. The chemical is drawn into the sea water stream by an eductor but because the water flow rates tend to be very high, either excessive dilution or high consumption of chemical may result. The output must therefore be controlled by the pumping rate or by bleeding off excess water. The concentration of dispersant in sea water should be adjusted to about 10%. Even so, efficient application is difficult because of the poor coverage of a strong water jet and there is a tendency for over-treatment and consequently, wastage of dispersant. The coverage by a fire hose can be improved by fitting an eccentric projection nozzle which can produce a 10 metre wide swath (see Fig. 2). Fire hoses or fire monitors can be particularly suited to dealing with small spills in confined spaces, such as under jetties. However, hydrocarbon solvent based dispersants should never be used from this equipment.

When hydrocarbon-based dispersants or diluted concentrates are to be applied from spray booms mounted on vessels, it is possible to achieve the required mixing by towing surface agitation boards through the treated slick (see Fig. 1). The dispersant is usually sprayed at a constant rate and the ratio of dispersant to oil can only be adjusted by varying the speed of the vessel or closing off one of the spray booms. In practice, the vessel can only travel between 4 and 10 knots, as this is the operating range of the surface agitation boards. The boards have proved troublesome to deploy from some vessels and crews are often unwilling to use them with the result that the effectiveness of the dispersant is greatly reduced. In order to rig the spray booms to withstand the towing forces, it is usually necessary to mount them midships or aft and with some vessels, when travelling at speeds greater than about 5 knots, the bow wave created may push the oil beyond the dispersants spray swath. This decreases the oil treatment rate and results in wastage of dispersant.

Since concentrate dispersants are more effective when used undiluted and do not require additional mixing, they allow greater flexibility and higher oil treatment rates. The spray booms can be mounted at the bow which overcomes the problem caused by the bow wave and allows vessels to travel faster while spraying. Because the freeboard of most vessels is greater at the bow, the spray booms can be made longer, giving a greater oil encounter width and further improving the potential treatment rate (see Fig. 2).

Two main approaches can be used to match the dispersant application rate to a particular





**Figure 2. Application of dispersants at sea.**

Ineffective use of dispersant on heavy fuel oil. Note high concentration of dispersant in surface waters.



*Left* – Extended spray boom (7.5 m) with wide angle nozzles for application of neat concentrate dispersant.

*Right* – Bow-mounted spraying equipment with eccentric projection nozzles.

ickness of oil: control of discharge rate or control of the vessel's speed. The following general relationship between the variables applies:

$$\text{Discharge rate (litres/min)} = \text{application rate (litres/m}^2\text{)} \times \text{speed (m/min)} \times \text{swath (m)}$$

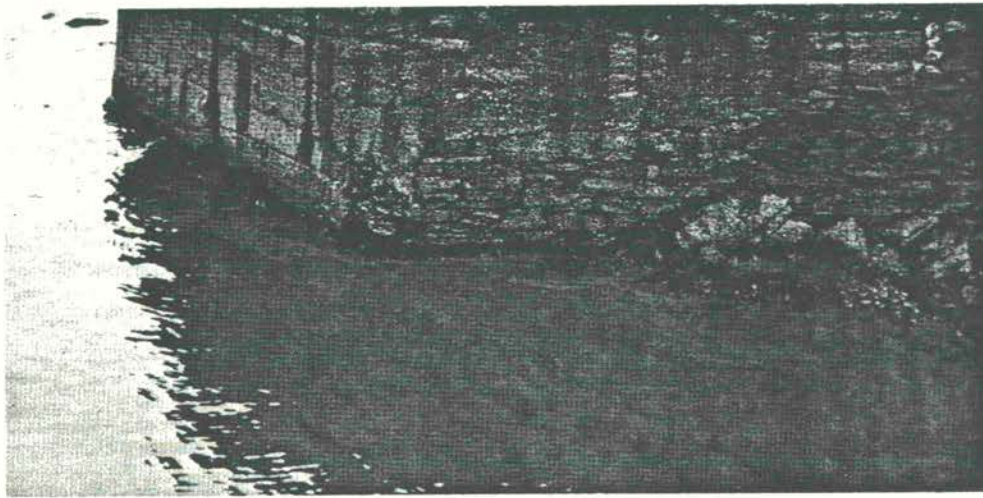
The application rate required is determined by the oil thickness. Once a slick has formed the oil rapidly reaches an average thickness of about 1 mm which represents an oil volume of 1 litres/m<sup>2</sup>. At a dosage of 1:20 the appropriate application rate would therefore be 0.005 litres/m<sup>2</sup>. Discharge rates can be varied providing the nozzles selected produce a stable spray and the discharge is monitored by a flow meter. Attention should be given to the viscosity of concentrate dispersants which limits the performance of both nozzles and flow meters.

Equipment currently available for applying neat concentrate has increased effective swath widths between 30 and 40 metres with flow rates ranging from 36 to 220 litres/min. (8 to 48 gallons/min.). Such high capacity spray systems

have the potential for excessive application rates leading to wastage of dispersant and it may be necessary to interchange nozzles in order to achieve the optimum application rate.

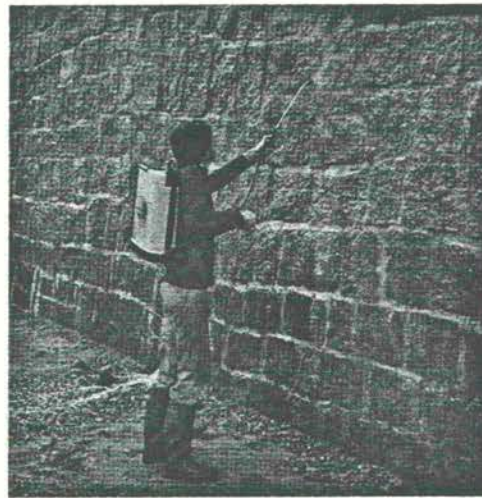
Despite these improvements, vessel spraying techniques will always have serious limitations particularly due to the low treatment rate and the inherent difficulties of locating from a vessel those slicks posing a significant threat. Furthermore, when oil slicks become fragmented or form narrow windrows, it is inevitable that some dispersant will be sprayed on to clean sea. These problems can be overcome to some extent by controlling the operation from an overflying aircraft and ensuring that the vessels are located in the heaviest concentrations of oil. Since aircraft are necessary in such an operation it is logical to consider them for applying the dispersant. Aerial spraying offers the advantages of rapid response, good surveillance, high treatment rates, optimum use of dispersant and good evaluation of dispersant treatment. It is now an established technique and is the subject of Technical Information Paper No. 3.





**Figure 3. Application of dispersant on shorelines.**

Appearance of chemically dispersed oil.



*Left* – Attempt to clean heavily contaminated shoreline with dispersant. Removal of bulk oil prior to dispersant treatment may have been more effective.

*Right* – Back pack spray unit for the application of dispersant to shorelines and man-made structures.

## 2. On shorelines

Dispersants can also be used on some shorelines, particularly during the final stages of clean-up. However, when pollution is heavy it is important to remove the bulk of the stranded oil first, by other means (see Fig. 3). Beaches subjected to strong wave action are often cleaned naturally and they should be left alone unless circumstances dictate the immediate removal of all the oil.

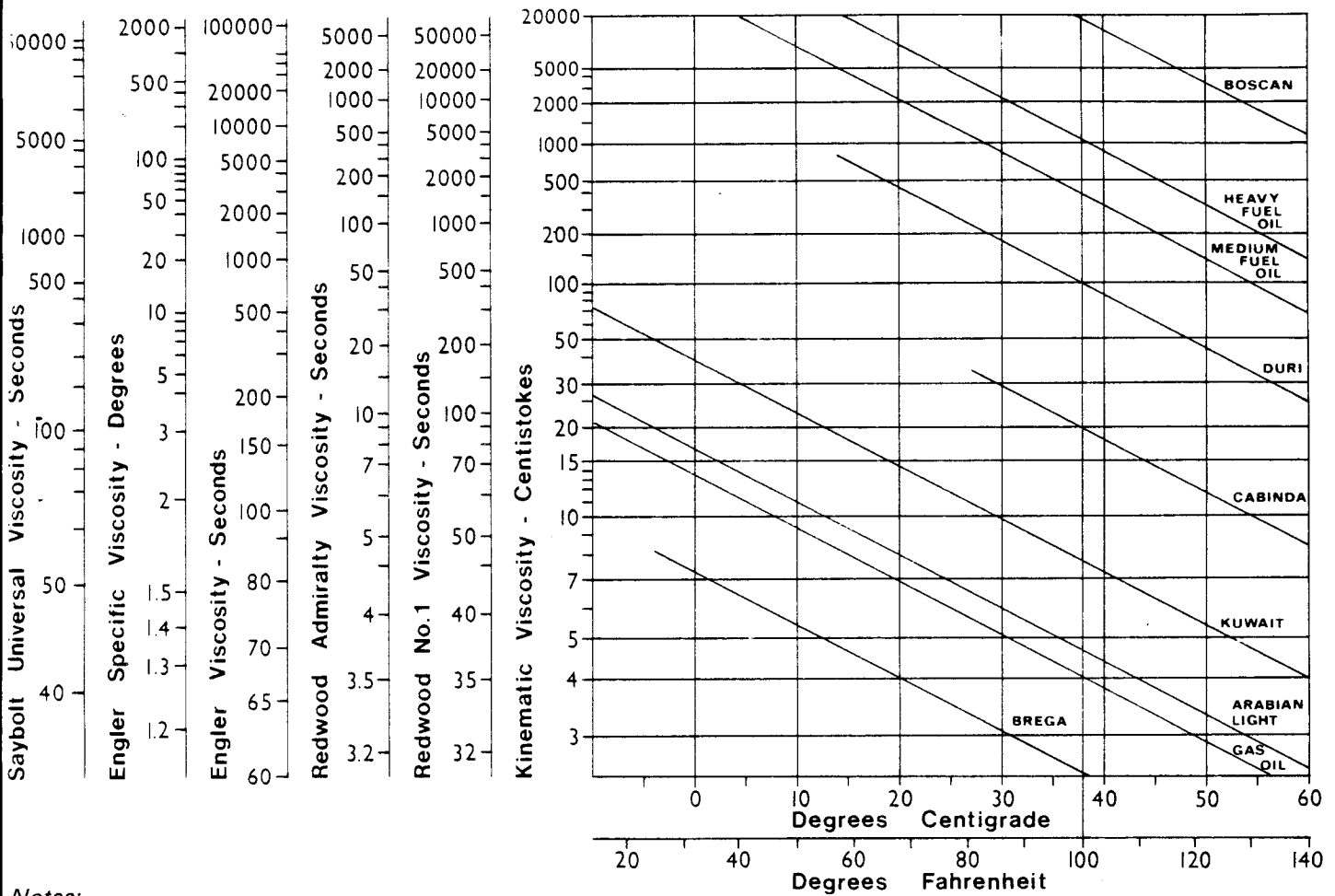
Both hydrocarbon-based dispersants and concentrates may be used for shore cleaning although the former type may be more effective with viscous oils because of the greater penetration achieved by the hydrocarbon solvent. Dispersant application rates should be in the same range as for use at sea. However, it is difficult to predict how effective dispersants will be against stranded oil and it is advisable to carry out a small scale field test before mounting a large scale operation. In the case of severe contamination, it is often preferable to clean oiled surfaces with two or more separate treatments rather than trying to remove all the oil with one application.

When using dispersants on shorelines, it is important to apply them in such a way that the beach is washed down within about 30 minutes to minimise penetration into beach material. The recommended way of using dispersant on tidal shorelines is to spray the chemical onto the oil just ahead of the advancing flood tide. On non-tidal shores gentle hosing with salt water can be considered, taking care not to drive the oil down into the substrate. The most appropriate equipment for application depends on the type of beach material to be cleaned, the ease of access and the scale of the operation. For small inaccessible beaches, portable back-pack sprayers, are the most suitable (see Fig. 3). For large expanses of beach, purpose-built vehicles, tractors or aircraft can be used.

Dispersants can also be used to clean rocks, sea walls and other man-made structures although it is often necessary to use brushes to aid mixing and high pressure hoses to remove treated oil from vertical surfaces and the undersides of rocks.



**Figure 4. Relationship between temperature and oil viscosity for representative crude and fuel oils.**



**Notes:**

1. Other oils can be plotted by entering a known viscosity value at the relevant temperature (see Table 1) and drawing a line parallel to existing ones.
2. Oils with viscosities exceeding 2000 centistokes at ambient temperature (for example Medium Fuel Oil colder than 20°C) are unlikely to be amenable to dispersants.
3. Gas Oil is also known as Light Diesel or No. 2 Fuel Oil (ASTM nomenclature) and ranges from 30-36 seconds Redwood No. 1 at 100°F.
4. Medium Fuel Oil is also known as No. 4 Fuel Oil (ASTM nomenclature) and ranges from 900-1500 seconds Redwood No. 1 at 100°F.
5. Heavy Fuel Oil is also known as Bunker C or No. 6 Fuel Oil (ASTM nomenclature) and ranges from 3000-10000 seconds Redwood No. 1 at 100°F.

**Environmental considerations**

Despite the fact that the toxicity of modern dispersants is very much less than the original formulations, their use still evokes controversy. Environmental concern stems mainly from the fact that the use of dispersants represents not only a deliberate introduction into the sea of an additional pollutant but can also result in an increase in hydrocarbon concentration in the water, which may lead to biological damage. There is a wealth of laboratory data on the toxicity of dispersants and oil/dispersant mixtures to a variety of marine organisms, but far less is known about their effects at actual spills where dilution usually reduces concentrations and exposure times significantly. The few studies that have been undertaken in areas where dispersants have been used extensively have not demonstrated significant effects on populations of particular species or biological communities. Conclusive evidence of increased tainting of commercial species resulting from dispersant usage is also not available.

An assessment of the dilution potential is the most useful basis for deciding whether dispersants can be used for protecting certain resources without risking undue damage to others. Relevant factors are the distance between the application site and sensitive areas as well as the direction of currents and the mixing depths of surface waters. It is frequently possible to make a rough estimate of both the maximum likely dispersant/oil concentration and the exposure time affecting a known location. In areas where the dilution potential is great, such as the open sea, high concentrations are unlikely to persist for more than a few hours and significant biological effects are therefore improbable. In shallow waters close to the shore where water exchange is poor, higher concentrations may persist for long periods and possibly approach values known to cause observable effects in laboratory experiments. Because of this, great concern is often expressed about the use of dispersants in such areas. Despite this greater risk, the controlled application of dispersants in these situations may on

**Table 2. Comparison of Dispersant Application Systems**

Spraying system	Type of dispersants	Maximum dispersant application rate litres/min.	Maximum oil treatment rate tons/hr.	Advantages	Disadvantages
BACK PACK UNITS	HYDROCARBON	2.5	0.3	Light, portable, cheap and readily available	Limited payload and application rate
	CONCENTRATE	2.5	3		
FIRE MONITORS	CONCENTRATE	10-70	1	Simple to operate, readily available on most vessels	Limited oil encounter rate, prone to wastage of chemical dispersant
WARREN SPRING OFFSHORE SPRAYING EQUIPMENT	HYDROCARBON	90	11	Relatively cheap, can be fitted to most types of vessel	Limited oil encounter rate, cumbersome breaker boards, cannot be mounted on bow to avoid bow wave effect – constant pumping rate
	CONCENTRATE	9.0	11		
WARREN SPRING INSHORE SPRAYING EQUIPMENT	HYDROCARBON	32	4	Relatively cheap – readily fitted to most vessels with 15 hp engine – can be adapted for shore clean-up	Limited oil encounter rate, cannot be bow mounted to avoid bow wave effect – constant pumping rate
	CONCENTRATE	3.2	4		
SPRAYING EQUIPMENT FOR NEAT CONCENTRATE	CONCENTRATE	220	74*	Relatively cheap – can be fitted to bow of most vessels – variable application rate	Very high potential for dispersant wastage due to poor control and high application rate
PIPER PAWNEE CROP SPRAYING AIRCRAFT	CONCENTRATE	120	40	Rapid response, high treatment rate – accurate distribution of chemical particularly for fragmented slicks – can land and take off from rudimentary airfields	Limited payload and endurance – single engined therefore only suitable for inshore waters
DOUGLAS DC6 SPRAYING AIRCRAFT	CONCENTRATE	400	400	Rapid response, very high treatment rate, particularly suited for very large spills	Requires dedicated aircraft – costly to maintain – requires large airfield

\*Based on a typical oil encounter rate for a vessel travelling at 10 knots and spraying a 40 metre swath.

occasions be beneficial overall in that it may reduce damage to adjacent ecologically sensitive shorelines.

The circumstances dictating the use of dispersants are seldom clear-cut and the choice is necessarily a compromise between other options, cost-effectiveness and conflicting priorities for protecting different resources from pollution damage. On occasions the potential benefit gained by using dispersants to protect coastal amenities, sea birds and intertidal marine life may far outweigh the disadvantages such as the chance of temporary tainting. Conversely, the dispersant option may be rejected in fish spawning areas in the open sea even if the risk of damage is very low. Despite the difficulties, it is important that an order of priority for the resources to be protected is established and the circumstances under which dispersants may be used are agreed upon before the occurrence of a spill.

### Contingency planning

The case for using dispersants in different locations and circumstances should be examined in advance so that equipment and materials can be sited and stored accordingly. Such measures reduce response time and improve the chances of

a successful operation. It is essential that spraying equipment is regularly checked and properly maintained. Operating crews should be given comprehensive training in its installation and methods of use and practical exercises should be held frequently. Personnel should be aware of precautions to be observed when using dispersant and it is recommended that protective clothing is worn including gloves and goggles.

It is necessary to stockpile chemicals in sufficient quantity to respond to the most likely size of spill or to sustain a first aid response in the event of a larger spill until such time as replacement stocks can be brought in. Dispersants can either be stored in 200 litre drums or in bulk containers. For quick response, storage in road tanker trailers can be particularly useful. Although most dispersants have a long shelf life, steel drums can often corrode from the outside leading to loss of chemical. Plastic drums are therefore preferable for long-term storage provided they are kept out of direct sunlight. Whether stored in bulk or in drums, portable transfer pumps will usually be necessary to reduce delays when loading vessels. Where dedicated vessels are employed it may be preferable to store the chemical in integral tanks on board. For most other vessels collapsible pillow tanks, of up to 4500 litre capacity (1000 gallons), can conveniently be placed on



back. If different chemicals are to be stored together it is important to ensure that they are compatible; hydrocarbon solvent-based dispersants and concentrates should not be mixed since this could lead to the formation of viscous gels.

The effectiveness of different dispersant chemicals varies considerably and it is always advisable to carry out either laboratory or field

tests to identify the best available product under the conditions expected. Both environmental factors and probable types of oil spilled should be considered. Government regulatory agencies in many countries have developed testing and approval procedures for this purpose to ensure that approved dispersants will biodegrade rapidly and cause minimal toxicity to marine life when used correctly.

### Points to remember

1. The application of dispersant enhances the natural break-up of oil thereby removing it from the water surface and protecting shorelines and other resources such as sea birds.
2. Two types of dispersant are available, hydrocarbon-based and concentrates. Concentrates may be used neat or diluted to 10% with seawater but are more effective undiluted. Hydrocarbon solvent based dispersants must not be diluted with water.
3. It is important to recognise the limitations of dispersants, in particular their inability to treat very viscous oils and water-in-oil emulsions. Since most crude oils spilled at sea rapidly become unamenable to dispersants, a fast response and high treatment rate are essential.
4. Whilst vessels are suitable for dealing with small spills close to port, aircraft potentially offer a more cost-effective response for larger spills offshore.
5. Dispersants should only be used for beach cleaning after gross pollution has been removed. Care must be taken to prevent the penetration of oil into beach material and to reduce damage to marine life caused by prolonged exposure to dispersant/oil mixtures.
6. In order to formulate a policy on the use of dispersants, the risk of environmental damage resulting from their use must be balanced against the probable effects of the untreated oil. Dilution potential will be an important consideration. The policy for dispersant use should be agreed in advance for each area.

---

**THE INTERNATIONAL TANKER OWNERS POLLUTION FEDERATION LIMITED** was established in 1968 to administer the Tankers Voluntary Agreement concerning Liability for Oil Pollution (TOVALOP). The Federation is actively involved in all aspects of combating spills in the marine environment and provides technical advice on contingency planning, clean-up measures and environmental effects. It is a comprehensive information source. This Technical Information Paper is one of a series based on the experience of the Federation's technical staff.

For further information contact:

**INTERNATIONAL TANKER OWNERS POLLUTION FEDERATION LTD.,**  
Staple Hall, Stonehouse Court, 87-90 Houndsditch, London, EC3A 7AX.  
Telephone: 01-621 1255 Telex: 887514

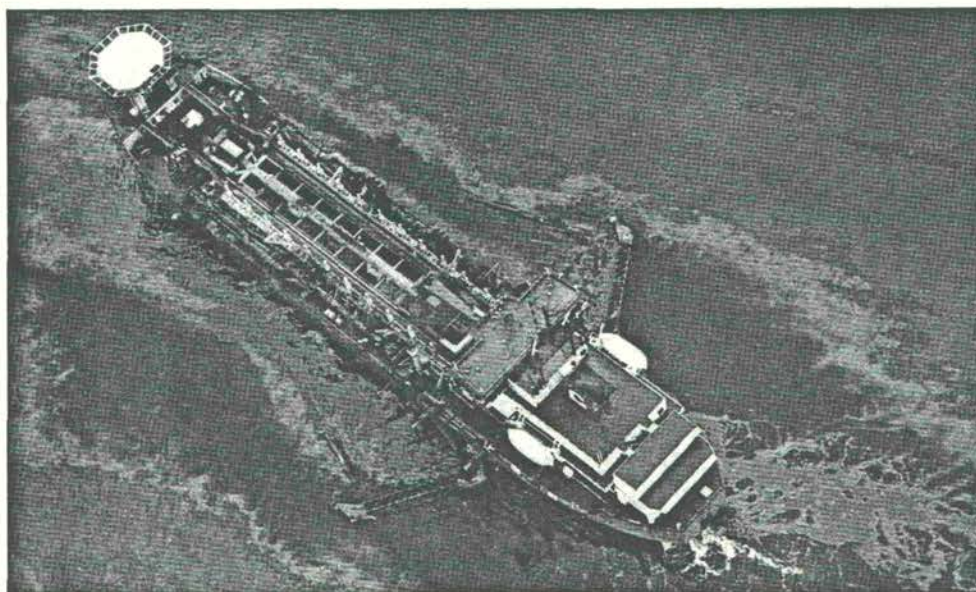


## USE OF SKIMMERS IN COMBATING OIL POLLUTION

### Introduction

A skimmer is any device designed to recover oil or oily/water mixtures from the surface of water, particularly where it has concentrated in thicker layers against a boom or other obstacle. Even moderate wave motion markedly reduces the effectiveness of skimmers and in the open sea few devices at present available operate well. More satisfactory performance can often be achieved in sheltered waters providing the type, viscosity and thickness of the oil is within the capabilities of the skimmer in question.

This paper describes the design and function of skimmers. Operating practices are discussed in relation to boom deployment since the dual problems of concentrating and removing spilt oil are closely linked. References are made to the deployment modes of booms described in Technical Information Paper No. 2, "Use of Booms in Combating Oil Pollution". The overall effectiveness of skimmers is also dependent upon an associated pumping capability to transfer collected oil. The use of pumps in all aspects of clean-up will be the subject of a separate paper.



1. Single ship collection system fitted to a dredger and consisting of sweeping arms and high capacity pumps for transferring the concentrated oil from the water surface to tanks on board.

### Design Principles

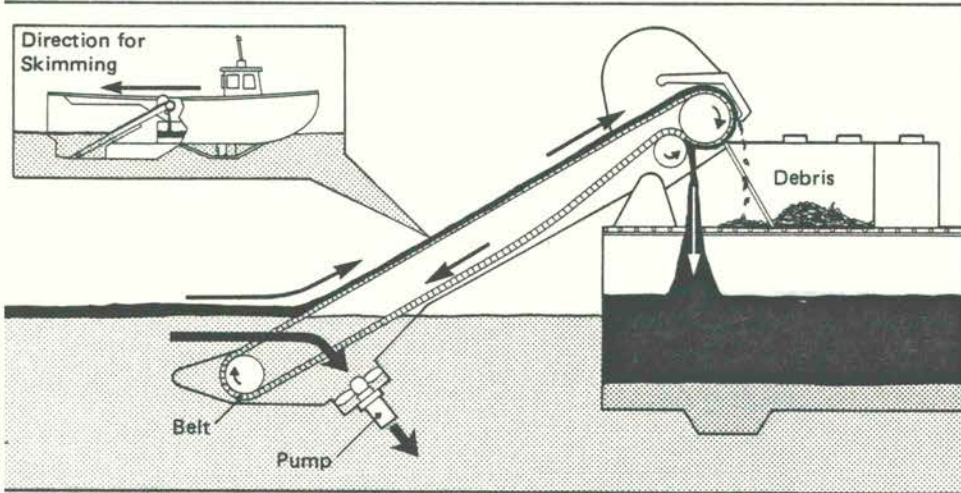
All skimmers incorporate an oil recovery element, some form of flotation or support arrangement and require a pump to transfer collected material to storage. More complicated designs may be self-propelled and may have several recovery elements, integral storage tanks or oil/water separation facilities. A summary of the characteristic features of the main types of skimmer is given in Figure 1.

Two basic approaches can be recognised. The simplest concept is a suction device whereby oil is collected by pumps or air suction systems from the water surface directly or via a weir. These designs tend to collect large volumes of water with the oil. This can be an advantage when using high capacity units to recover viscous oils which otherwise tend to block hoses and pipework. A large storage and oil/water separation capability is required to receive and process the water which



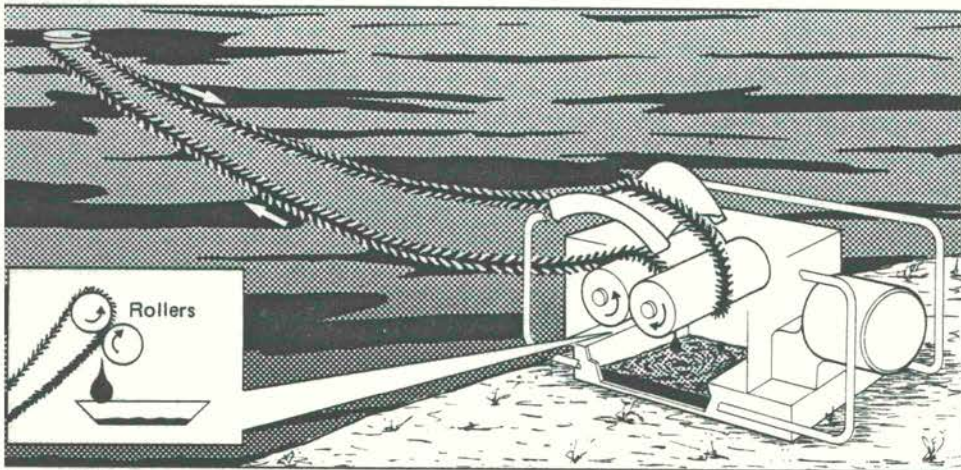
Figure 1. SKIMMER TYPES

ADHESION DEVICES



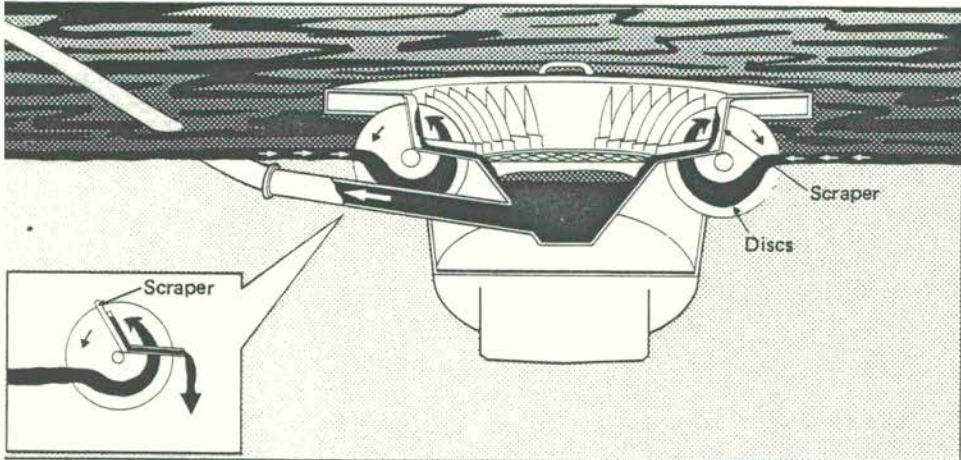
**Belt skimmers**

The belt conveys the oil from the water surface by adhesion. Upward rotating belts carry the oil to their top limit where it is scraped or squeezed off into a storage tank. Conversely, downward rotating belts first submerge the oil which then surfaces behind the belt, due to its buoyancy, into a defined area within the vessel. Operational limit – for upward rotating belts 0.5 knots, sea state 1; for downward rotating belts 2 knots, sea state 2. Preference – medium viscosity oils but upward rotating belts also tolerate heavier material.



**Oleophilic rope skimmers**

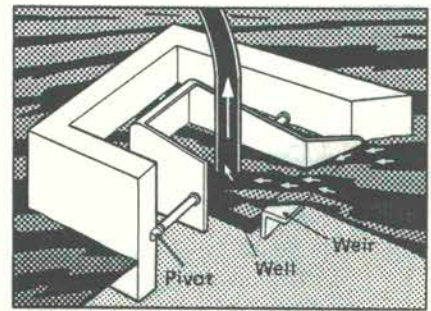
A central tension core rope, through which is interwoven oleophilic strands forming long continuous mop. The floating mop is pulled by powered rollers around a return pulley. The rollers squeeze the oil into a storage tank. Operational limit – sea state 3. Sensitive to increasing viscosity. Preference medium viscosity oils.



**Disc skimmers**

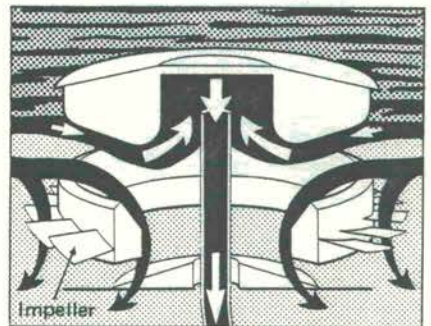
Discs rotate through the oil/water interface. Oil adheres to the disc surface, is moved by scraper to a central collection point and is pumped to storage. Operational limit – sea state 2. Sensitive to emulsified oils, waves, debris. Preference – medium viscosity oils.

SUCTION DEVICES



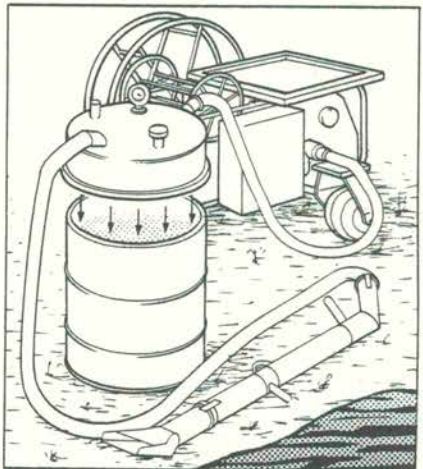
**Weir skimmers**

Oil flows over a self-levelling weir into the well of the skimmer and is pumped to storage. Operational limit – sea state 1. Sensitive to higher viscosity oils, emulsified oils, waves and debris. Preference – free-flowing oils.



**Vortex skimmers**

A vortex induced by an impeller causes the oil to concentrate at the centre of the vortex due to centrifugal effects. The collected oil is pumped from the top and the free water released from the bottom. Operational limit – sea state 2 and 0.5 kt water movement. Sensitive to debris. Preference – free-flowing oils.



**Air suction skimmers**

Vacuum system or an air conveyor attached to a hose which may be fitted with specially designed skimmer heads. The pumping of more viscous materials is possible by increasing the water content. Operational limit – sea state 3. Vacuum systems more sensitive to debris. Preference – light to medium viscosity oils but air conveyors can tolerate high viscosity oils.



frequently represents more than 90% of the collected material. For oil spill control purposes, simple gravity separation in settling tanks is adequate.

In contrast, skimmers which utilise the oleophilic properties of belts, drums, discs or synthetic ropes often achieve a higher ratio of recovered oil in relation to water. They work best with medium viscosity oils between 100 and 2000 centistokes. Low viscosity oils like diesel or kerosene do not accumulate on the oleophilic surfaces in sufficiently thick layers for high recovery rates to be attained. High viscosity materials like heavy bunker oil are excessively sticky and prove difficult to remove, but in contrast viscous water-in-oil emulsions can be almost non-adhesive.

Skimmers are designed so that the oil recovery element is positioned at the oil/water interface. This is usually achieved by a self-levelling arrangement but none are effective in steep waves although swell alone does not generally interfere with skimmers. Small units are easily swamped and pitched around, whilst larger skimmers possess greater inertia and are unable to follow the wave profiles. In currents exceeding 0.7 knots the performance of skimmers is impaired due to the tendency for floating oil to escape confinement by booms. This limitation is partly overcome in self-propelled skimmers where a sorbent mop array or belt is rotated so that its velocity relative to the floating oil is effectively reduced when the vessel is underway.

Many factors should be considered when selecting skimmers. The intended use and expected operational conditions should first be identified before criteria such as size, robustness and ease of operation, handling and maintenance of skimmers can be weighed up. The most important factors to consider are the viscosity and adhesive properties of spilt oil including any change in these properties over time. In predictable situations such as at marine terminals and refineries the type of oil handled is known and a specialised skimmer can be selected in preference to a versatile one.

### Performance

The pumping phase of the skimming process often determines the overall performance of a device because all pumps lose efficiency, albeit at different rates, as oil viscosity increases. Some specialised screw pumps have a very high viscosity tolerance and can deal with solidified oil, but the internal resistances of hoses and pipes may then become limiting instead. These problems can be overcome by carrying small amounts of oil with large volumes of induced air or water which act as a fluidising medium.

Hoses carrying oil from the skimmer should be fitted with the correct flotation to prevent them interfering with the behaviour of the skimmer. All hoses can prove troublesome to handle when oily and should be fitted with effective but simple couplings. A selection of adapters can prove useful for matching hoses of different diameters and joining incompatible connectors.

Because of the various constraints imposed on skimmers in the field, their design capacities are rarely achieved. Experience from numerous spills has consistently shown that oil cannot be expected to be concentrated sufficiently to sustain recovery rates achieved under test conditions. Test results may therefore be misleading and should be used for comparative purposes only.

Skimmers require power for the recovery element or for transferring the collected oil to a storage tank. Many systems are designed with an integral power pack. Diesel power can be used directly or to drive electric, hydraulic or pneumatic systems. All but petrol engines can be built to conform with safety regulations imposed in refineries, tank farms and other restricted areas where there may be a risk of fire and explosion.

As their name implies, skimmers are designed to recover floating oil but experience has shown that their performance is disappointing unless they can be deployed in calm waters and in thick layers of oil. However, in these situations a simple suction device such as a vacuum truck may achieve comparable or even better recovery rates provided it can be positioned close to the concentration of oil.

### Operating practices

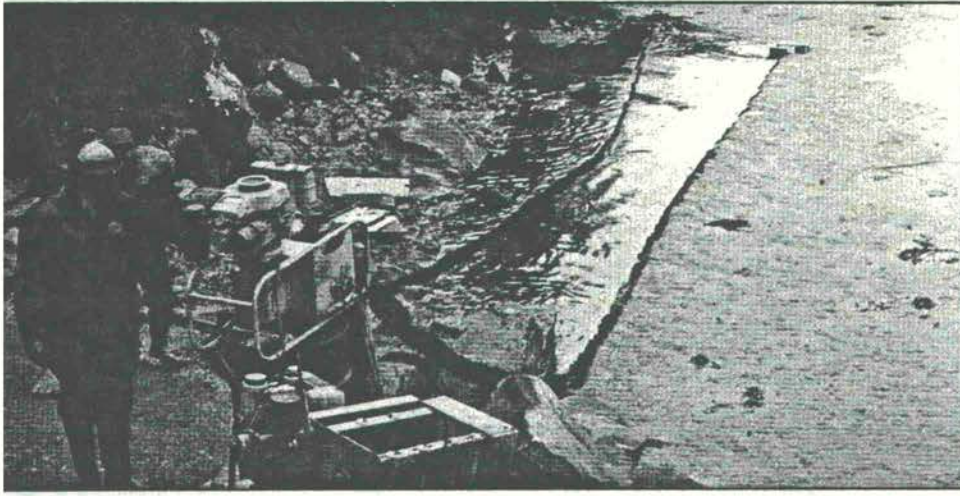
Only rarely is it possible to use a skimmer effectively without the aid of a boom to concentrate and retain floating oil. Deployment strategies for booms, as described in Technical Information Paper No. 2, will therefore largely determine the operating practices for skimmers. At sea, towed systems involve skimmers deployed from vessels. Moored systems are used in nearshore shallow water and skimmers are usually deployed from land.

#### *At sea*

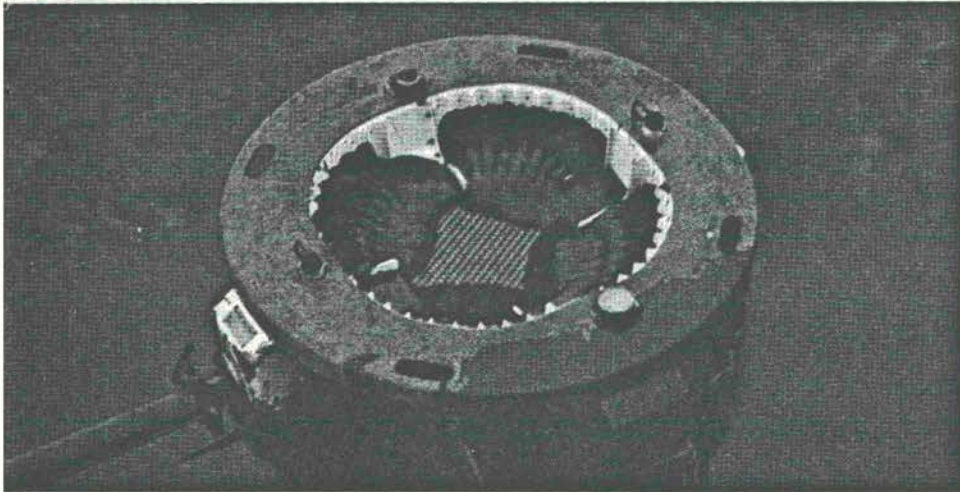
To concentrate floating oil at sea, booms can be towed in U, V or J configurations using two vessels. The recovery device is either deployed from one vessel (Fig. 2a) or towed as part of the boom array (Fig. 2b). In both cases the problems of coordinating a multi-ship system are severe. The skimmer should be kept in the maximum thickness of oil, yet the boom must be protected from abrasion and other mechanical damage. Wave reflection against large skimmers can interfere with the oil flow to the recovery element. Skilful handling of the equipment is called for with continuous adjustments as conditions change. Ideally the vessel used as a working platform should have lifting gear on deck and sufficiently good manoeuvrability to quickly assume a selected position and maintain it against winds and currents. The rate of oil concentration by towed booms can be slow and a single skimmer may be sufficient to serve several boom arrays.

In practice it is only rarely that any success has been achieved in recovery operations involving several vessels. An alternative solution is to combine oil concentration, recovery and storage

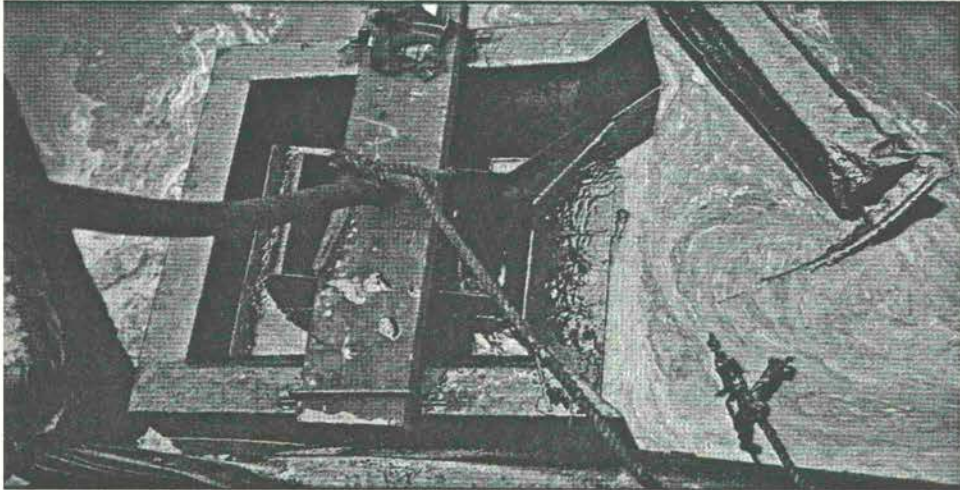




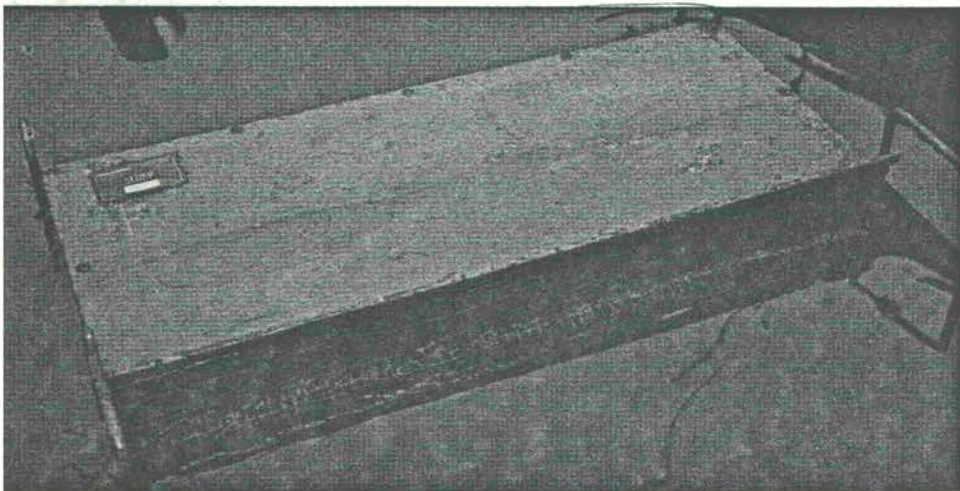
2. Oleophilic rope skimmer operating from the shore with the rope passing through two floating pulleys.



3. Oleophilic disc skimmer recovering a medium viscosity oil.



4. Weir skimmer operating in heavy crude oil. Note adverse effect of viscosity on the flow of oil over the weir.

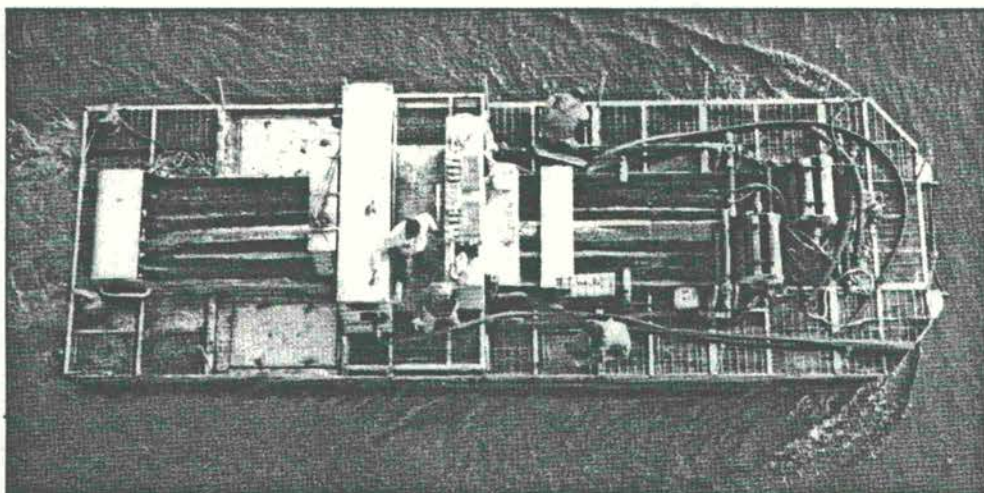


5. Weir skimmer being used to collect fresh crude oil. Note trash screen which may become blocked by debris.

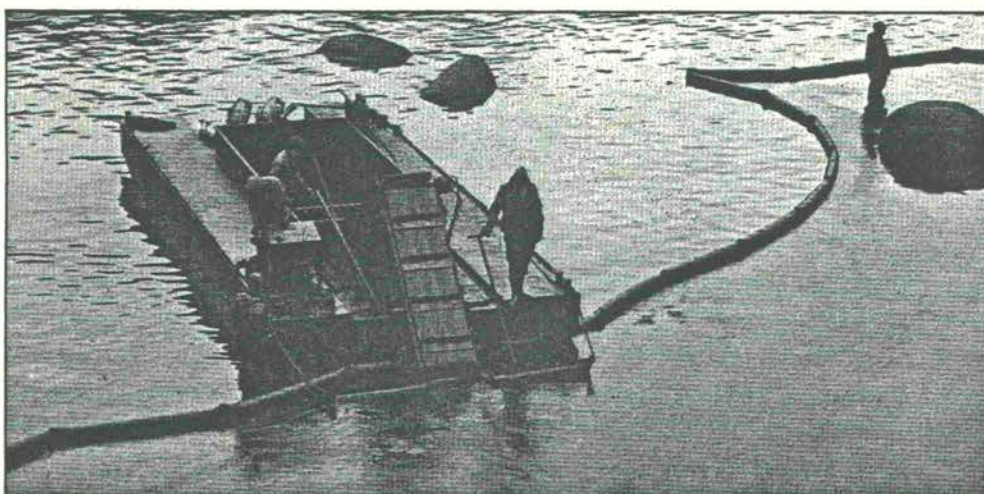




6. Catamaran-mounted disc skimmer operating in ice.



7. Oleophilic rope skimmers deployed from a self-propelled catamaran. The ropes pass between the hulls so that their velocity relative to floating oil is reduced.



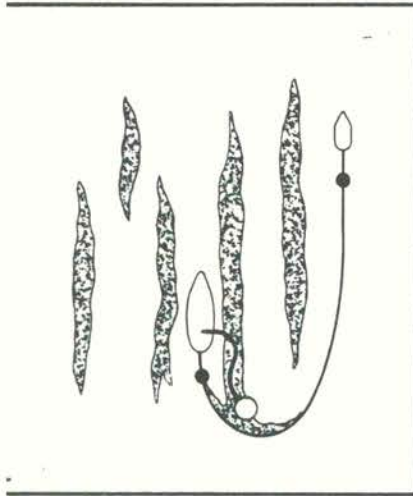
8. Belt skimmer fitted to a small barge and used to recover emulsified weathered crude oil.



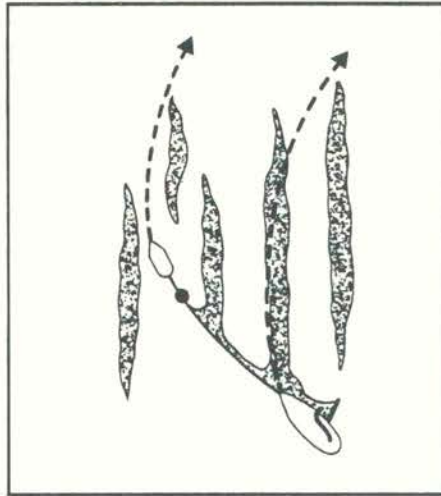
9. Tractor-towed vacuum unit collecting pools of emulsified crude oil from a polluted beach.



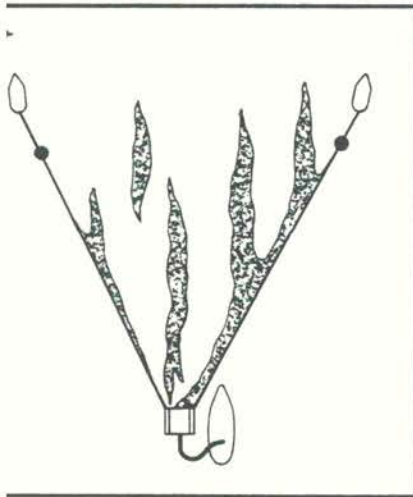
## Figure 2. TOWING CONFIGURATIONS OF BOOMS AND SKIMMERS



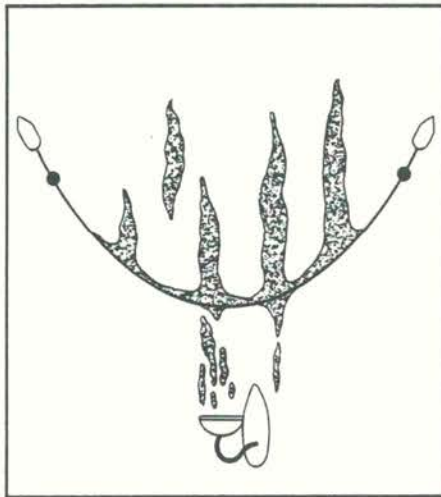
(a) J configuration towed by two vessels, one of which deploys the recovery device.



(c) Single ship system extended with additional vessel towing boom to increase the encounter rate.



(b) V configuration towed by two vessels – collection device towed with boom array and oil transferred to third vessel.



(d) U configuration towed by two vessels at 1–2 knots. Oil escaping behind boom is intercepted by a single ship system.

functions in a single ship system. This consists of rigid or flexible sweeping arrangement, a high capacity pump and tankage. Single ship systems operate relatively well in up to sea state 3 and can recover viscous oils, but with substantial quantities of water. Therefore adequate tank space must be available onboard to allow for oil/water separation.

Two simple improvements to increase the oil counter rate of single-ship systems can be considered (see Figs. 2c and 2d). The first is for a tall vessel to hold taut a relatively short length boom attached to the collection vessel. The two vessels maintain the formation with the aim of deflecting oil into the sweeping arrangement. The second method requires two vessels towing a longer length of boom at 1-2 knots. Oil escaping behind the boom as a narrow streak may be covered by the single ship system.

A common difficulty with recovery operations at sea is controlling the movements and activities of vessels. This can be overcome by using aircraft equipped with air to sea communications. Helicopters have the advantage of a hovering capability and can operate from a base close to the spill.

### Nearshore

Self-propelled skimmers can be used to good effect in the calmer waters of ports and harbours where they may also serve some secondary function such as debris collectors. These vessels are often an integral part of response arrangements for oil terminals and refineries where the pollution risk is relatively well known and a planned response is straightforward. Self-propelled skimmers are comparatively expensive but have a known performance and work best in confined areas, particularly where access from the shore is impractical. However, clean-up work should be suspended if there is a risk of fire and explosion, for instance in ports.

In common with other floating materials, oil accumulates in particular places along the shore under the influence of wind and water movement and can be further concentrated with the aid of booms. It is in such positions that skimmers have to be deployed and they must therefore be capable of operating in the presence of debris. It may be necessary to work from shallow-draught vessels but it is usually easier to operate skimmers from the shore particularly if road access, hard standing or a flat working area is available close



to the oil collection point.

Once the best possible site has been identified careful thought must be given to providing logistic support. All skimmers require supervision to ensure that oil is reaching the collection element and debris is not accumulating to reduce efficiency or cause damage. Repair will usually require trained personnel and access to replacement parts. Many skimmers are fitted with trash screens which can become blocked by oil or debris with surprising frequency. At night regular inspections must be made and when necessary the skimming equipment operated using flood-lighting. To maintain a high performance the skimming speed should be adjusted to suit conditions and to match the rate at which oil is arriving at the collection site. If only small amounts of oil are present, skimming should be carried out at intervals to avoid excessive collection of water. Rope mops can be deployed effectively inside a boom to collect small quantities of oil along its length.

With the skimmer in thick layers of oil, the rate

of recovery is determined by pump capacity, which in turn is strongly dependent on oil viscosity. Where viscosity increases are due to water-in-oil emulsion formation, chemical emulsion breakers can be employed providing they are mixed in well. The application of steam heating is also worthwhile to reduce blocking of pumps and hoses. Temporary oil storage facilities will be required for collected material and to allow the water to be drained off.

After use skimmers should be cleaned and overhauled to identify and rectify any wear and damage. Steam lances or solvents can be used to remove oil but cleaning chemicals should not be used on sorbent mops and plastic discs. Skimmers and their power packs should be protected from damage and damp, salt atmospheres causing corrosion. Sorbent mops, rubber belts and plastic materials incorporated in skimmers will perish if exposed to direct sunlight for long periods. Regular inspections and testing of equipment are essential particularly as its use may be infrequent.

### Points to remember

1. Assess the merits of oil recovery options at sea and nearshore against prevailing conditions such as sea state, wind, water movements and the location of areas needing protection.
2. Take account of the type of oil to be recovered, its viscosity at ambient temperatures and any change with time.
3. Then select an appropriate skimmer from the types available against the criteria of capacity, reliability, robustness, field performance, weight, handling, versatility, power source, maintenance and cost.
4. Identify the availability of vacuum trucks and other suction systems which may be employed for recovering thick layers of oil on calm waters.
5. Use aircraft for monitoring and controlling oil recovery operations at sea.
6. Monitor skimmer performance continuously to ensure optimum efficiency.
7. Ensure that the logistics of pumping, storing and disposing of recovered oil are addressed.
8. Arrange regular inspections and testing of equipment to maintain personnel training standards and rectify any equipment faults.

---

THE INTERNATIONAL TANKER OWNERS POLLUTION FEDERATION LIMITED was established as a non-profit making organisation in 1968 to administer the Tanker Owners Voluntary Agreement concerning Liability for Oil Pollution (TOVALOP). The Federation is actively involved in all aspects of combating oil spills in the marine environment and provides technical advice on contingency planning, clean-up measures and environmental effects. It is also a comprehensive information source. This Technical Information Paper is one of a series based on the experience of the Federation's technical staff.

*For further information contact:*

INTERNATIONAL TANKER OWNERS POLLUTION FEDERATION LTD.,  
Staple Hall, Stonehouse Court, 87-90 Houndsditch, London, EC3A 7AX.  
Telephone: 01-621 1255 Telex: 887514

---