



Réunion des points focaux du MED POL

Téléconférence, 27-28 mai et 6-7 octobre 2021

Point 12 de l'ordre du jour : Harmonisation et normalisation de la surveillance du cluster IMAP Pollution

- a) **Directives / protocoles de suivi pour les indicateurs communs IMAP 13, 14, 17, 18, 20 et 23**
- b) **Directives / protocoles de surveillance pour l'assurance qualité analytique et la communication des données de surveillance pour les indicateurs communs IMAP 13, 14, 17, 18 et 20**
- c) **Directives / protocoles de surveillance pour les microplastiques flottants**

Directives/Protocoles de contrôle concernant la préparation et l'analyse des échantillons des échantillons des produits de la mer pour l'indicateur commun 20 de l'IMAP : métaux lourds, éléments traces et polluants organiques

Pour des raisons environnementales et économiques, le tirage du présent document a été restreint. Les participants sont priés d'apporter leur copie à la réunion et de ne pas demander de copies supplémentaires.

Table des matières

1	Introduction	1
2	Note technique pour l'analyse des échantillons de tissus de poissons et de fruits de mer pour la recherche de métaux lourds	3
	2.1 Protocole pour la digestion des tissus du biote à l'aide d'acide nitrique.....	5
	2.2 Protocole pour l'analyse des métaux lourds à l'aide de la AAS.....	7
	2.3 Protocole pour l'analyse des métaux lourds avec la GF-AAS.....	8
	2.4 Protocole pour l'analyse des métaux lourds par ICP-MS.....	8
	2.5 Protocole pour l'analyse du Hg total dans les échantillons d'origine marine par spectrométrie d'absorption atomique à vapeur froide (CV-AAS).....	9
3	Note technique pour l'analyse d'échantillons de tissus de fruits de mer pour la recherche de contaminants organiques	10
	3.1 Protocole pour l'analyse des dioxines et des PCB de type dioxine par GC-HRMS.....	13
	3.2 Protocole pour l'analyse des PCB autres que les dioxines dans les fruits de mer par GC-ECD ..	14
	3.3 Protocole pour l'analyse des PCB autres que les dioxines dans les fruits de mer par GC-MS.....	15
	3.4 Protocole pour l'analyse du benzo(a)pyrène (HAP) dans les fruits de mer par GC-FID.....	15
	3.5 Protocole pour l'analyse des benzo(a)pyrènes (HAP) dans les fruits de mer par GC-MS	16

Annexes

- Annex I:** EU Commission Regulation (EC) No 1881/2006, setting maximum levels for certain contaminants in seafood (1.1.2.);
- Annex II:** EU Commission Regulation No 835/2011 amending (EC) No 1881/2006 in relation to PAHs maximum levels;
- Annex III:** EU Commission Regulation (EC) No 836/2011 amending (EC) No 333/2007 laying down the methods of sampling and analysis for the official control of the levels of lead, cadmium, mercury, inorganic tin, 3-MCPD and benzo(a)pyrene in foodstuffs
- Annex IV:** EU Commission Regulation (EC) No 644/2017. Laying down methods of sampling and analysis for the control of levels of dioxins, dioxin-like PCBs and non-dioxin-like PCBs in certain foodstuffs (1.1.4);
- Annex V:** EU Commission Regulation (EC) No 1259/2011, amending Regulation (EC) No 1881/2006 as regards maximum levels for dioxins, dioxin-like PCBs and non-dioxin-like PCBs in foodstuffs (1.1.9);
- Annex VI:** IAEA (2011a). Recommended method on microwave digestion of marine samples for the determination of trace element content (IAEA/Marine Environmental Studies Laboratory in co-operation with UNEP/MAP MED POL)
- Annex VII:** IAEA (2011b) Recommended method for the determination of selected trace element in samples of marine origin by flame atomic absorption spectrometry
- Annex VIII:** IAEA (2011c) Recommended method for the determination of selected trace element in samples of marine origin by atomic absorption spectrometry using graphite furnace
- Annex IX:** HELCOM (2012a). Manual for marine monitoring in the COMBINE programme. Annex B-12, Appendix 4: Technical note on the determination of trace metallic elements in biota (5.1.1.);
- Annex X:** US EPA (1994) US-EPA Method 200.8: Determination of trace elements in waters and wastes by inductively coupled plasma-mass spectrometry (5.1.2.);
- Annex XI:** IAEA (2012a) Recommended method on the determination of Total Mercury in marine samples by thermal decomposition, amalgamation and Atomic Absorption Spectrophotometry.);
- Annex XII:** IAEA (2012b). Recommended method on the determination of Total Hg in samples or marine origin by Cold Vapour Atomic Absorption Spectrometry (5.1.3);

- Annex XIII:** HELCOM (2012b). COMBINE Annex B-12, Appendix 4, Attachment 1. Technical note on the determination of Total Mercury in marine biota by Cold Vapour Atomic Absorption Spectroscopy (5.1.4.);
- Annex XIV:** UNEP/IAEA (2011d). Sample work-up for the analysis of selected chlorinated hydrocarbons in the marine environment. Reference Methods for Marine Pollution Studies No 71. (4.2.1.);
- Annex XV:** HELCOM (2012c). Manual for marine monitoring in the COMBINE programme. Annex B-12, Appendix 3. Technical note on the determination of chlorinated biphenyls and organochlorine pesticides in biota (5.2.1.);
- Annex XVI:** HELCOM (2012d). Manual for marine monitoring in the COMBINE programme. Annex B-12, Appendix 2. Technical Note on the determination of Polycyclic Aromatic Hydrocarbons in Biota (5.2.3);
- Annex XVII:** ICES/OSPAR (2018). CEMP Guidelines for monitoring contaminants in biota and sediments. ANNEX 1: Polyaromatic hydrocarbons in biota - Determination of parent and alkylated PAHs in biological materials (5.2.4.);
- Annex XVIII:** US EPA (1994) Method 1613, Revision B: Tetra- through octachlorinated dioxins and furans by isotope dilution HRGC/HRMS, EPA 821-B94-0059. Office of Water, US Environmental Protection Agency, Washington, DC (9.2.1.);
- Annex XIX:** US EPA (2008) Method 1668, Revision B: Chlorinated biphenyl congeners in water, soil, sediment, and tissue by HRGC/HRMS, EPA-821-R-08-020. Office of Water, US Environmental Protection Agency, Washington, DC (9.2.2.);
- Annex XX:** Maximum levels for certain foodstuffs, Heavy Metals – (EC) Regulation 1881/2006;
- Annex XXI:** References

Note du Secrétariat

Conformément au programme de travail 2020-2021 adopté par la COP21, le programme MED POL a préparé les lignes directrices de surveillance relatives aux indicateurs communs 13, 14, 17 et 20 de l'IMAP en vue de leur examen lors de la réunion intégrée des groupes de correspondance sur la surveillance de l'approche écosystémique (CORMON) (décembre 2020), tandis que les lignes directrices de surveillance pour l'indicateur commun 18 ainsi que les lignes directrices de surveillance relatives à l'assurance qualité et à la communication des données sont en cours de finalisation en vue de leur examen lors de la réunion du CORMON sur la surveillance de la pollution prévue en avril 2021.

Ces lignes directrices de surveillance contiennent des manuels cohérents destinés à guider le personnel technique des laboratoires compétents IMAP des Parties contractantes pour la mise en œuvre des pratiques de surveillance normalisées et harmonisées liées à un indicateur commun IMAP spécifique (c'est-à-dire l'échantillonnage, la conservation et le transport des échantillons, la préparation et l'analyse des échantillons, ainsi que l'assurance qualité et la communication des données de surveillance). Pour la première fois, ces lignes directrices présentent un résumé des meilleures pratiques connues disponibles et utilisées dans la surveillance du milieu marin, en exposant des pratiques analytiques globales intégrées qui pourront être appliquées afin de garantir la représentativité et l'exactitude des résultats analytiques nécessaires à la production de données de surveillance de qualité assurée.

Les lignes directrices/protocoles de surveillance s'appuient sur les connaissances et les pratiques acquises au cours des 40 années de mise en œuvre de la surveillance du MED POL et sur des publications récentes, mettant en évidence les pratiques actuelles des laboratoires maritimes des Parties contractantes ainsi que d'autres pratiques issues des conventions sur les mers régionales et de l'Union européenne. Une analyse approfondie des pratiques actuellement disponibles du PNUE/PAM, du PNUE et de l'AIEA ainsi que d'HELCOM, d'OSPAR et du Centre commun de recherche de la Commission européenne a été entreprise afin de contribuer à une approche novatrice pour la préparation des lignes directrices/protocoles de surveillance de l'IMAP.

Les lignes directrices/protocoles de surveillance abordent également les problèmes identifiés lors de la réalisation des épreuves de compétence organisées par l'UNEP/MAP-MEDPOL et l'AIEA depuis deux décennies maintenant, les nombreux résultats insatisfaisants dans le cadre des tests inter laboratoires pouvant être liés à des pratiques inadéquates au sein des laboratoires compétents de l'IMAP/MEDPOL.

Afin de soutenir les efforts nationaux, les présentes Lignes directrices pour la préparation des échantillons et l'analyse des produits de la mer pour l'Indicateur commun 20 du IMAP contiennent les deux notes techniques suivantes : a) Note technique pour l'analyse des échantillons de produits de la mer pour les métaux lourds, qui comprend les cinq protocoles suivants : i) Protocole pour la digestion des tissus du biote par l'acide nitrique ; ii) Protocole pour l'analyse des métaux lourds par spectroscopie d'absorption atomique de flamme (F-AAS) ; iii) Protocole pour l'analyse des métaux lourds par spectroscopie d'absorption atomique en four graphite (GF-AAS) ; iv) Protocole pour l'analyse des métaux lourds par spectroscopie de masse à plasma inductif (ICP-MS) ; v) Protocole pour l'analyse du Hg total avec décomposition thermique, amalgame et spectrométrie d'absorption atomique (AAS) ; vi) Protocole pour l'analyse du Hg total avec la spectrométrie d'absorption atomique à vapeur froide (CV-AAS) ; b) Note technique pour l'analyse des échantillons de produits de la mer pour les contaminants organiques, qui comprend les quatre protocoles suivants : i) Protocole pour l'analyse des dioxines et des PCB de type dioxine par chromatographie en phase gazeuse - spectrométrie de masse à haute résolution (GC-HRMS) ; ii) Protocole pour autres que ceux de type dioxine dans le biote marin utilisant la chromatographie en phase gazeuse avec détection par capture d'électrons. iii) Protocole pour l'analyse des non dioxines, comme les PCB dans le biote marin utilisant la chromatographie en phase gazeuse avec spectrométrie de masse (GC-MS); iv) Protocole d'analyse des HAP dans le biote

marin par Chromatographie Liquide Haute Performance – Fluorescence (HPCL_UVF) ; v) Protocole pour l'analyse des HAP dans le biote marin utilisant la chromatographie gazeuse et la spectrométrie de masse (GC-MS).

Les lignes directrices/protocoles de surveillance, y compris celui-ci relatif à la préparation des échantillons et à l'analyse des produits de la mer pour l'Indicateur commun 20 du IMAP, établissent une base solide pour une mise à jour régulière des pratiques de surveillance en vue d'une mise en œuvre réussie de l'IMAP.

Conformément aux conclusions et recommandations des réunions intégrées des groupes de correspondance sur la mise en œuvre de l'approche écosystémique de l'IMAP (CORMON) (vidéoconférence, 1-3 décembre 2020), et en particulier au paragraphe 22, la Réunion des CORMON a demandé au Secrétariat de modifier les Lignes directrices/Protocoles de surveillance en abordant les propositions techniques convenues qui ont été décrites dans le rapport de la Réunion et de soumettre l'ensemble de ces documents à la réunion des points focaux du MED POL. Les amendements demandés comprenaient des suggestions techniques écrites qui ont été fournies par plusieurs Parties contractantes jusqu'à 10 jours après la réunion intégrée des CORMON. Le document amendé a été partagé par le Secrétariat le 19 février 2021 pour une période de 2 semaines pour la non-objection des réunions intégrées des CORMON sur les changements introduits. Suite à l'absence d'objection de la réunion intégrée des CORMON, cette directive de suivi est soumise à l'examen de la présente réunion des points focaux MED POL.

Liste des abréviations/acronymes

CI	Indicateur commun
CU	Commission européenne
CdP	Conférence des parties
CORMON	Groupe de correspondance sur la surveillance
EcAp	Approche écosystémique
EEA	Agence environnementale européenne
FAO	Organisation des Nations Unies pour l'alimentation et l'agriculture
HELCOM	Commission pour la protection du milieu marin dans la zone de la mer Baltique – Commission d'Helsinki
IAEA	Agence internationale de l'énergie atomique
IOC	Commission océanographique intergouvernementale
IMAP	Programme de surveillance et d'évaluation intégrées de la mer et des côtes méditerranéennes et les critères d'évaluation connexes
LOD	Limite de Détection
LOQ	Limite de Quantification
MED POL	Programme coordonné de surveillance continue et de recherche en matière de pollution dans la Méditerranée
MED QSR	Rapport sur la qualité de la Méditerranée
Milli-Q water	Eau déionisée ultra-pure
OSPAR	Convention pour la protection du milieu marin de l'Atlantique du nord- est
PAM	Plan d'action pour la Méditerranée
PdT	Programme de travail
PNUE	Programme des Nations Unies pour l'Environnement
QA/QC	Assurance qualité / Contrôle qualité
QSR	Rapport sur la qualité
UE	Union Européenne
US EPA	Agence américaine de protection de l'environnement

1 Introduction

1. Les teneurs maximales autorisées pour certains contaminants dans les denrées alimentaires (y compris les produits de la mer) ont été fixés par la FAO/OMS (Codex Alimentarius¹) et les règlements de la Commission européenne (règlements de la Commission européenne (CE) n° 1881/2006² (annexe I), (CE) n° 835 /2011³ (annexe II) et CE n° 1259/2011⁴ (annexe IV).

Conformément à ces règlements, les concentrations maximales autorisées dans les produits de la mer sont fixées pour le cadmium (Cd), le plomb (Pb), le mercure (Hg), les quatre HAP (benzo(a)pyrène, benz(a)anthracène, benzo(b)fluoranthène et chrysène), dioxines (y compris furanes), les PCB de type dioxine et PCB non dioxines.

2. Selon les fiches d'orientation de l'IMAP (PNUE/PAM 2019⁵), la surveillance recommandée de la liste des contaminants dans le cadre de l'indicateur commun 20 (CI20) de l'IMAP comprend le Cd, le Pb, le Hg, les quatre HAP et les PCB autres que les dioxines, tandis que les dioxines et les PCB de type dioxine ne sont pas encore inclus dans la liste des contaminants à déclaration obligatoire de l'IMAP.

3. En ce qui concerne les métaux lourds, les métaux réglementés pour la surveillance des produits de la mer dans le cadre de la CI20 (Cd, Pb et Hg) sont les mêmes que les métaux obligatoires pour la surveillance du biote marin dans le cadre de la CI17. Par conséquent, les méthodes d'analyse pour la détermination des métaux dans les tissus des fruits de mer (muscles des poissons, corps entier des bivalves, chair des crustacés et des céphalopodes) sont identiques aux protocoles d'analyse pertinents présentés dans l'IC17.

4. Concernant les contaminants organiques réglementés, les HAP (Benzo(a)pyrène, benz(a)anthracène, benzo(b)fluoranthène et chrysène), et les PCB non apparentés aux dioxines (PCB 28, PCB 52, PCB 101, PCB 138, PCB 153 et PCB 180) sont inclus dans les listes des contaminants réglementés pour l'IC20 et des contaminants à déclaration obligatoire pour l'IC17 (biote). Par conséquent, les méthodes d'analyse pour leur détermination dans les fruits de mer sont identiques aux protocoles d'analyse pertinents présentés dans l'IC17.

5. Les autres contaminants réglementés par la CE (dioxines et PCB de type dioxine) ne sont pas inclus dans les contaminants à déclaration obligatoire de l'IC17 et ils nécessitent des laboratoires spécialisés accrédités disposant d'un équipement analytique approprié (comme le GC-HRMS). Les méthodes d'analyse des dioxines et des PCB de type dioxine sont présentées ci-dessous dans le Protocole pour l'analyse des dioxines et des PCB de type dioxine par chromatographie en phase gazeuse avec spectrométrie de masse. Les parties contractantes à la Convention de Barcelone peuvent décider d'inclure l'analyse de métaux lourds et de contaminants organiques supplémentaires non réglementés dans leurs programmes nationaux de surveillance de la CI20, bien qu'aucune limite maximale admissible de consommation n'ait pas encore été définie. En raison de l'absence de valeurs maximales admissibles pertinentes pour les contaminants non réglementés, aucun rapport adéquat ne peut être fourni pour ces contaminants supplémentaires.

6. Les Protocoles préparés dans le cadre des Directives de surveillance pour la préparation et l'analyse d'échantillons d'aliments marins selon l'Indicateur 20 commun de l'IMAP (*Monitoring Guidance for Sample Preparation and Analysis of Sea Food for IMAP Common Indicator 20*), tels que présentés ci-dessous, décrivent les méthodologies appropriées pour l'analyse des échantillons de fruits de mer pour la détermination des métaux lourds et des contaminants organiques, afin d'assurer la qualité des données. Ils ne sont pas destinés à être des manuels de formation analytique, mais des

¹ Codex Alimentarius (FAO/WHO) : <http://www.fao.org/fao-who-codexalimentarius>

² EU Commission Regulation (EC) No 1881/2006, setting maximum levels for certain contaminants in seafood (Annex I)

³ Commission Regulation (EU) No 835/2011 amending Regulation (EC) No 1881/2006 as regards maximum levels for polycyclic aromatic hydrocarbons in foodstuffs.

⁴ EU Commission Regulation (EC) No 1259/2011, amending Regulation (EC) No 1881/2006 as regards maximum levels for dioxins, dioxin-like PCBs and non-dioxin-like PCBs in foodstuffs (Annex IV);

⁵ (PNUE 2019). UNEP/MED WG.467/5. IMAP Guidance Factsheets: Update for Common Indicators 13, 14, 17, 18, 20 and 21: New proposal for candidate indicators 26 and 27;

lignes directrices pour les laboratoires méditerranéens, qui doivent être testés et modifiés afin de valider leurs résultats finaux.

7. Ces protocoles visent à rationaliser la préparation et l'analyse des échantillons de biotes marins en vue d'assurer une assurance qualité comparable des données, ainsi que la comparabilité entre les zones d'échantillonnage et les différents programmes de surveillance nationaux, en fournissant une orientation étape par étape sur les méthodes à appliquer en Méditerranée.

8. Afin d'éviter les répétitions inutiles, il est également fait référence aux protocoles déjà publiés et accessibles au public, qui peuvent également être utilisés par les laboratoires compétents des parties contractantes participant à la mise en œuvre de l'IMAP. Concernant l'analyse des métaux lourds, les protocoles IMAP ci-dessous s'appuient sur les lignes directrices pertinentes élaborées par le PNUE/AIEA (Annexe VI : IAEA (2011a). Méthode recommandée sur la digestion par micro-ondes d'échantillons marins pour la détermination de la teneur en éléments traces ; Annexe VII : Méthode recommandée pour la détermination d'éléments traces sélectionnés dans des échantillons d'origine marine par spectrométrie d'absorption atomique à flamme ; Annexe VIII : Méthode recommandée pour la détermination d'éléments traces sélectionnés dans des échantillons d'origine marine par spectrométrie d'absorption atomique à l'aide d'un four en graphite ; Annexe XI : Méthode recommandée pour la détermination du mercure total dans les échantillons marins par décomposition thermique, amalgame et spectrophotométrie d'absorption atomique ; et Annexe XII : Méthode recommandée pour la détermination du Hg total dans les échantillons ou d'origine marine par spectrométrie d'absorption atomique à vapeur froide), HELCOM (programme COMBINE) (Annexe IX : Note technique sur la détermination des éléments traces métalliques dans le biote ; Annexe XIII : Technique note sur la détermination du mercure total dans le biote marin par spectroscopie d'absorption atomique à vapeur froide) et l'US EPA (Annexe X : US-EPA Method 200.8 : Determination of oligo elements in waters and wastes by inductively couplé plasma-mass spectrometry). Pour l'analyse des contaminants organiques, les protocoles IMAP élaborés ci-dessous s'appuient sur les directives pertinentes élaborées par le PNUE/AIEA (Annexe XIV : Méthodes de référence pour les études sur la pollution marine n° 71 pour l'analyse de certains hydrocarbures chlorés dans le milieu marin) ; HELCOM (Annexe XV : programme COMBINE, Note technique sur la détermination des biphenyles chlorés et des pesticides organochlorés dans le biote ; Annexe XVI : programme COMBINE, Note technique sur la détermination des hydrocarbures aromatiques polycycliques dans le biote) ; ICES/OSPAR (Annexe XVII : Lignes directrices du CEMP pour la surveillance des contaminants dans le biote et les sédiments) et US EPA (Annexe XVIII : US EPA Method 1613, Tetra- through octachlorinated dioxins and furanes by isotope dilution HRGC/HRMS ; Annexe XIX : US EPA Method 1668, congénères de biphenyle chloré dans l'eau, le sol, les sédiments et les tissus par HRGC/HRMS). Compte tenu de la pertinence de l'une de ces lignes directrices dans le contexte de l'IMAP, elles pourraient être utilisées par les laboratoires méditerranéens compétents de l'IMAP intéressés pour développer leurs méthodologies d'échantillonnage et de traitement des échantillons spécifiques aux laboratoires. Les laboratoires des Parties contractantes doivent s'adapter et toujours tester et modifier chaque étape des procédures pour valider leurs résultats.

9. Le diagramme ci-dessous indique la catégorie de cette directive de surveillance relative à la préparation et à l'analyse des échantillons de fruits de mer pour l'Indicateur commun 20 du IMAP dans la structure de toutes les directives de surveillance préparées pour les Indicateurs communs 13, 14, 17, 18 et 20 de l'IMAP.



Diagramme de flux : Lignes directrices pour la surveillance des objectifs écologiques 5 et 9 de l'IMAP

2 Note technique pour l'analyse des échantillons de tissus de poissons et de fruits de mer pour la recherche de métaux lourds

10. Les métaux réglementés pour le contrôle des fruits de mer dans le cadre de la CI20 sont le Cd, le Pb et le Hg. Les laboratoires nationaux peuvent décider d'utiliser toute méthode d'analyse validée qu'ils jugent appropriée et qui répond à des critères de performance spécifiques (LD, LOQ, précision, récupération et spécificité - Règlement de l'UE (CE) n° 836/2011⁶ (annexe III), modifiant le règlement (CE) 333/2007⁷). Des détails sur les exigences spécifiques pour les méthodes d'analyse, concernant l'utilisation des critères de performance et l'approche « d'aptitude à l'emploi » sont également fournis dans le Règlement.

Critères de performance pour les méthodes d'analyse du plomb, du cadmium et du mercure, tels que définis dans le règlement (CE) n° 333/2007

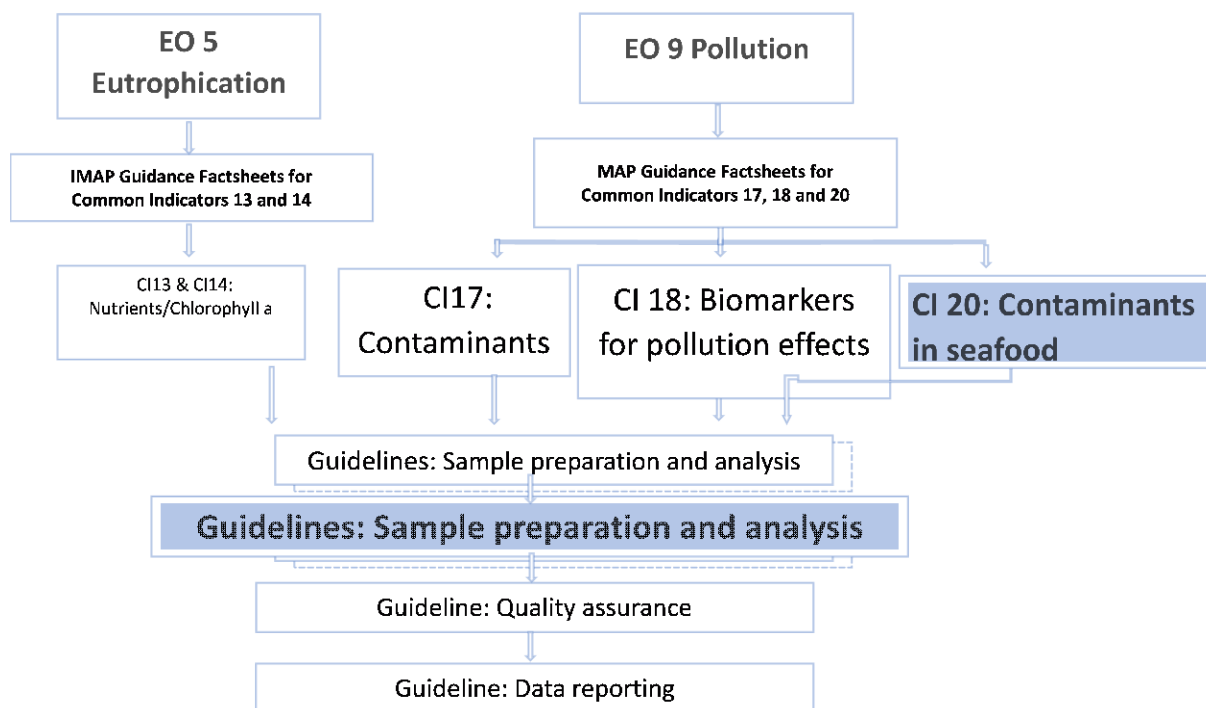
Paramètre	Valeur/observation
Applicabilité	Aliments spécifiés dans le règlement (CE) n° 1881/2006
LOD	Un dixième de la teneur maximale prévue dans le règlement (CE) n° 1881/2006, sauf si la teneur

⁶ EU Commission Regulation (EC) 836/2011 amending Commission Regulation (EC) No 333/2007, laying down the methods of sampling and analysis for the official control of the levels of lead, cadmium, mercury, inorganic tin, 3-MCPD and benzo(a)pyrene in foodstuffs

⁷ EU Commission Regulation (EC) No 333/2007, laying down the methods of sampling and analysis for the official control of the levels of lead, cadmium, mercury, inorganic tin, 3-MCPD and benzo(a)pyrene in foodstuffs

	maximale en plomb est inférieure à 100 µg/kg. Pour ces derniers, moins d'un cinquième du niveau maximal
LOQ	Un cinquième de la teneur maximale fixée dans le règlement (CE) n° 1881/2006, sauf si la teneur maximale en plomb est inférieure à 100 µg/kg. Pour ces derniers, moins de deux cinquièmes du niveau maximal
Précision	HORRAT _r ou HORRATR valeurs inférieures à 2 *
Récupération	Les dispositions du point D.1.2. s'appliquent **
Spécificité	Exemptes d'interférences matricielles ou spectrales

* 'HORRAT_r' = la RSD_r observée divisée par la valeur de la RSD_r estimée à partir de l'équation d'Horwitz en utilisant l'hypothèse $r = 0,66R$. (M. Thompson, analyste, 2000, 125, 385-386.)

'HORRAT_R' = la valeur RSD_R observée divisée par la valeur RSD_R calculée à partir de l'équation d'Horwitz.

** D.1.2. Calculs de rectification : Le résultat peut être déclaré non corrigé (pour les métaux) si la preuve est apportée, en utilisant idéalement un matériau de référence certifié approprié, que la concentration certifiée permettant l'incertitude de mesure est atteinte (c'est-à-dire une grande précision de la mesure). Si le résultat n'est pas corrigé, cela doit être mentionné.

11. Afin d'aider les laboratoires d'analyse des parties contractantes, des protocoles IMAP ont été préparés dans le cadre de ce document afin d'être utilisés comme lignes directrices pour l'analyse des métaux lourds (Cd, Hg et Pb) dans les échantillons de fruits de mer. Les protocoles IMAP sont ceux proposés pour l'analyse du biote marin dans le cadre du CI17. Les laboratoires d'analyse doivent adapter, tester et modifier chaque étape des procédures présentées dans les protocoles afin de valider leurs résultats finaux. La liste des méthodes et du matériel d'analyse n'est pas exhaustive et les laboratoires sont encouragés à utiliser leur propre matériel/méthodes qu'ils jugent adéquats pour les analyses requises.

12. L'analyse des métaux lourds dans les échantillons du biote marin développée pour la surveillance du CI17, qui est également recommandée pour les métaux lourds dans les échantillons de fruits de mer pour la surveillance du CI20, comprend : i) la digestion des tissus et ii) l'analyse de l'échantillon digéré pour les métaux lourds en utilisant différents équipements. Ils sont prévus dans les protocoles IMAP suivants :

- Protocole pour la digestion des tissus de fruits de mer à l'aide d'acide nitrique (digestion assistée par micro-ondes en système fermé et digestion sur plaque chauffante) ;
- Protocole pour l'analyse des métaux lourds par spectroscopie d'absorption atomique de flamme (F-AAS) ;
- Protocole pour l'analyse des métaux lourds par spectroscopie d'absorption atomique à four graphite (GF-AAS) ;
- Protocole pour l'analyse des métaux lourds par spectroscopie de masse à plasma inductif (ICP-MS) ;
- Protocole pour l'analyse du Hg total avec décomposition thermique, amalgame et AAS ;
- Protocole pour l'analyse du Hg total par spectrométrie d'absorption atomique à vapeur froide (CV-AAS).

13. Ces protocoles sont basés sur les méthodes analytiques élaborées par l'AIEA (annexes VI, VII, VIII, XI, XII), HELCOM (annexes IX et XIII) et l'US EPA (annexe X).

14. Quelle que soit la méthode d'analyse utilisée, les analyses de métaux lourds suivent certaines procédures communes à toutes les méthodes d'analyse, telles que l'étalonnage des équipements d'analyse et les procédures de nettoyage et de manipulation pour éviter la contamination des échantillons par l'environnement du laboratoire et les outils et récipients utilisés pour l'analyse.

a) Étalonnage

15. Normes d'étalonnage établies à partir de solutions mères standard uniques ou de normes multi-éléments, par dilution de la solution mère à l'aide d'acide dilué, selon les besoins. Toutes les solutions standard doivent être stockées dans des flacons volumétriques en polyéthylène, en borosilicate ou en quartz, selon la meilleure adéquation aux analytes respectifs. Les solutions étalons à faible concentration, si elles sont préparées correctement et contrôlées dans le cadre d'un système d'assurance qualité (vérification de l'ancienne par rapport à la nouvelle, et vérification avec des étalons provenant d'une autre source), peuvent être conservées pendant une période ne dépassant pas un mois

16. La procédure d'étalonnage doit répondre à certains critères de base afin de donner la meilleure estimation de la concentration réelle en éléments de l'échantillon analysé (HELCOM, 2012a) :

- i) Les concentrations des étalons pour la préparation de la courbe d'étalonnage doivent couvrir la gamme des concentrations prévues ;
- ii) La précision analytique requise doit être connue et réalisable dans toute la gamme des concentrations ;
- iii) La valeur mesurée à l'extrémité inférieure de la gamme doit être significativement différente du blanc analytique de procédure ;
- iv) Les propriétés chimiques et physiques des étalons doivent ressembler étroitement à celles de l'échantillon étudié ;
- v) Les instruments d'analyse doivent être réétalonnés régulièrement (tous les 10 à 20 échantillons) afin de corriger la dérive instrumentale et l'efficacité analytique.

b) Éviter la contamination

17. Pour éviter la contamination des métaux dans le laboratoire, tous les récipients en verre et en plastique utilisés doivent être soigneusement nettoyés. Les directives générales de nettoyage comprennent :

- i) Les récipients doivent être laissés à tremper toute la nuit dans une cuve en plastique dans une solution alcaline de tensioactifs (2 % dans l'eau du robinet ou mieux encore dans l'eau distillée) ;
- ii) Les récipients sont rincés à fond, d'abord avec de l'eau du robinet ou mieux encore de l'eau distillée, puis avec de l'eau déionisée ultra-pure (18 MΩ cm, par exemple Milli-Q).
- iii) Les récipients sont laissés dans une solution de HNO₃ concentrée à 10% (v/v) (qualité analytique) à température ambiante pendant au moins 6 jours.
- iv) Les récipients sont rincés à fond avec de l'eau déionisée ultra-pure (par exemple Milli-Q) (au moins 4 fois).
- v) Il est possible de sécher les récipients sous une hotte à flux laminaire.
- vi) Les récipients sont stockés dans des sacs en polyéthylène fermés (par exemple, de type zip-lock) pour éviter tout risque de contamination avant utilisation.

18. Cette procédure doit être utilisée pour tous les articles en plastique utilisés en laboratoire comme les embouts, les gobelets pour échantillonneur automatique, les récipients en plastique. Laissez les récipients reposer dans une solution de HNO₃ concentrée à 10% (v/v) (qualité analytique) à température ambiante pendant au moins 6 jours

2.1 Protocole pour la digestion des tissus du biote à l'aide d'acide nitrique

19. Les échantillons de tissus du biote doivent être digérés (incinération humide) avant l'analyse. La vitesse de digestion et l'efficacité de la décomposition de l'acide augmentent considérablement

avec des températures et une pression élevées, c'est pourquoi la digestion par micro-ondes dans des récipients fermés est la méthode préférée. Toutefois, si un tel équipement n'est pas disponible, la digestion des échantillons dans des récipients ouverts sur une plaque chauffante est une méthode alternative. Les échantillons de biote peuvent être digérés à l'état humide ou sec, mais quelle que soit la méthode appliquée, il est d'une importance capitale de garantir la destruction complète de toute la matière organique de l'échantillon, ainsi que d'éviter les pertes de métaux et la contamination de l'échantillon (HELCOM, 2012a)⁸.

20. L'existence de composés de carbone organique dissous résiduels dans l'échantillon digéré modifierait la viscosité de la solution et pourrait donc entraîner des résultats erronés lorsque l'étalonnage de l'instrument AAS est effectué à l'aide de solutions étalons aquatiques. De plus, dans le GF-AAS, le carbone organique résiduel peut subir des réactions secondaires avec l'analyte avant ou pendant le processus d'atomisation, provoquant des interférences avec la matrice (Harms, 1985⁹).

a) Digestion acide par micro-ondes en systèmes fermés (pour l'analyse des métaux lourds par AAS, GFAAS et ICP-MS)

21. La digestion des tissus du biote peut être effectuée dans du téflon, ou dans des récipients de qualité équivalente en matériau pur, qui sont exempts de métal et résistants aux acides forts, ce qui réduit considérablement les pertes d'éléments par volatilisation et la contamination par désorption des impuretés de la surface du récipient. De plus, comme seules de petites quantités d'acide nitrique de haute pureté sont utilisées, il est possible d'obtenir des blancs d'analyse extrêmement faibles. Les systèmes à micro-ondes permettent un transfert d'énergie très rapide vers l'échantillon et une montée en température et en pression interne très rapide de la cuve, avec l'avantage d'une réduction énorme du temps de digestion (HELCOM, 2012a).

Réactifs de digestion pour l'analyse du Cd, du Pb et d'autres oligo-éléments

- i) HNO₃ (65%, Suprapur, Merck).
- ii) H₂O₂ (qualité analytique) à conserver au réfrigérateur après ouverture.
- iii) Eau déionisée par système Milli-Q (> 18 MΩ cm, Millipore).

22. Selon la méthode recommandée par l'AIEA (2011a¹⁰) sur la digestion par micro-ondes d'échantillons marins pour la détermination de la teneur en éléments traces (Annexe VI), les échantillons de tissus de biote séchés (environ 0,2 g) sont pesés dans la cuve à micro-ondes et placés dans une hotte laminaire compatible avec les fumées acides. On ajoute environ 5 ml d'acide nitrique (HNO₃) à chaque cuve et on laisse réagir pendant au moins une heure (ou plus si possible). Après la pré-digestion à température ambiante, 2 ml de peroxyde d'hydrogène (H₂O₂) sont ajoutés avec précaution, les récipients sont fermés et placés dans l'appareil à micro-ondes et les étapes de digestion sont suivies.

Réactifs de digestion pour l'analyse du mercure

- i) HNO₃ (65 %, qualité analytique, faible teneur en mercure).
- ii) Eau déionisée par système Milli-Q (> 18MΩ cm).
- iii) Solution à 10% K₂Cr₂O₇ (w/v) (par ex. 10 g K₂Cr₂O₇ de qualité analytique diluée dans 100 ml d'eau filtrée avec Milli-Q).

23. Les échantillons de tissus de biote séchés (environ 0,2 à 1,5 g selon la concentration prévue) sont pesés dans le récipient à micro-ondes et placés dans une hotte laminaire compatible avec les

⁸ HELCOM (2012a). Manual for marine monitoring in the COMBINE programme. Annex B-12, Appendix 4: Technical note on the determination of trace metallic elements in biota.

⁹ Harms, U. 1985. Possibilities of improving the determination of extremely low lead concentrations in marine fish by graphite furnace atomic absorption spectrometry. Fresenius Journal of Analytical Chemistry, 322: 53-56.

¹⁰ IAEA (2011a). Recommended method on microwave digestion of marine samples for the determination of trace element content (IAEA/Marine Environmental Studies Laboratory in co-operation with UNEP/MAP MED POL)

fumées acides. Si vous traitez des bivalves de poids élevé (> 1 g), ajoutez 40 mg de V_2O_5 à chaque tube (y compris les blancs). Ajouter 5 ml d'acide nitrique concentré (HNO_3) et laisser réagir pendant au moins 1 heure. Si une grande quantité d'échantillons est utilisée, il faut ajouter plus d'acide jusqu'à ce que le mélange devienne liquide. Pour contrôler le rendement de la procédure de digestion, au moins 2 blancs doivent être préparés de la même manière que les échantillons pour chaque lot d'analyse. De plus, au moins un matériau de référence certifié doit être utilisé et préparé en double pour chaque lot de digestion. Ces digestions sont préparées de la même manière que les échantillons. Un matériau de référence de composition et de concentration similaires doit être utilisé. Après la digestion, les récipients sont retirés de l'appareil à micro-ondes et placés dans une hotte ventilée pour refroidir. Lorsque la pression est suffisante, on ouvre les récipients, on ajoute 1 ml de solution de $K_2Cr_2O_7$ (la concentration finale doit être de 2% v/v) et on transfère leur contenu dans une éprouvette graduée, de préférence en téflon, mais le verre est également bon, et on le porte à un volume connu. Tous les réactifs doivent être de qualité analytique.

b) La digestion acide dans les systèmes ouverts

24. Si aucun système de digestion par micro-ondes n'est disponible, il est possible d'effectuer une digestion sur une plaque chauffante programmable placée à l'intérieur d'une hotte spécialement conçue à cet effet, ce qui permet de traiter les acides. Cependant, pour la destruction complète de la matière organique, il faut généralement de grandes quantités de réactifs et des appareils volumineux avec de grandes surfaces et la méthode est sujette à des problèmes de contamination (les valeurs de blanc trop élevées) si des acides insuffisamment purifiés sont utilisés. De plus, la vitesse de réaction et l'efficacité de la décomposition de l'acide dans les récipients ouverts sont plus faibles que dans les récipients fermés sous pression. Par conséquent, la digestion sur une plaque chauffante n'est pas une méthode recommandée et doit être évitée si possible.

25. Les échantillons de tissus de biote séchés (environ 0,2 g) sont pesés dans le récipient à micro-ondes et placés dans une hotte à flux laminaire compatible avec les fumées acides. Environ 5 ml d'acide nitrique concentré (HNO_3) sont ajoutés dans chaque récipient et laissés à réagir à température ambiante pendant au moins une heure. Les tubes sont fermés et placés dans un bloc d'aluminium sur une plaque chauffante à 90 °C pendant 3 heures. On laisse les échantillons refroidir à température ambiante, puis on ouvre les tubes avec précaution et on transfère les échantillons dans les tubes gradués de 50 ml en polypropylène étiquetés ou dans la fiole volumétrique. Tous les réactifs sont de qualité analytique.

26. Une méthode de digestion des tissus du biote dans des systèmes ouverts, utilisant l'eau régale, $HNO_3 / HClO_4$ peut être trouvée dans Black et al, (2013¹¹).

2.2 Protocole pour l'analyse des métaux lourds à l'aide de la AAS

27. La spectroscopie d'absorption atomique de flamme (F-AAS) a une sensibilité adéquate pour la détermination d'un large éventail de métaux dans les tissus du biote marin. La solution de l'échantillon est aspirée dans une flamme et atomisée. Dans le cas de la AAS à flamme, un faisceau lumineux est dirigé à travers la flamme, dans un monochromateur, et sur un détecteur qui mesure la quantité de lumière absorbée par l'élément dans la flamme. Chaque métal a sa propre longueur d'onde caractéristique, c'est pourquoi on utilise une lampe à cathode creuse composée de cet élément. La quantité d'énergie absorbée à la longueur d'onde caractéristique est proportionnelle à la concentration de l'élément dans l'échantillon.

28. Un protocole analytique détaillé pour l'analyse des métaux lourds dans les échantillons de tissus du biote par spectrométrie d'absorption atomique à flamme préparé par l'AIEA (2011b¹²) est

¹¹ Black, K., Kalantzi, I., Karakassis, I., Papageorgiou, N., Pergantis, S., Shimmield, T. (2013). Heavy metals, trace elements and sediment geochemistry at four Mediterranean fish farms, Science of the Total Environment. 444, 128–137.

¹² IAEA (2011b) Recommended method for the determination of selected trace element in samples of marine origin by flame atomic absorption spectrometry

présenté dans l'annexe VII : Méthode recommandée pour la détermination d'éléments traces sélectionnés dans des échantillons d'origine marine par flamme spectrométrie d'absorption atomique.

2.3 Protocole pour l'analyse des métaux lourds avec la GF-AAS

29. Dans les tissus du biote marin, le Cd, le Pb, ainsi que d'autres métaux lourds, peuvent être déterminés par la spectroscopie d'absorption atomique à four graphite (GF-AAS), qui a une sensibilité adéquate pour ces déterminations. Pour l'analyse du GF-AAS, après la digestion de l'échantillon de biote, une aliquote de la solution d'échantillon (10-50 µl) est introduite dans un tube en graphite du GF-AAS et atomisée par chauffage rapide à haute température. Un faisceau lumineux est dirigé à travers le tube en graphite, dans un monochromateur, et sur un détecteur qui mesure la quantité de lumière absorbée par l'élément atomisé dans le tube. Chaque métal a sa propre longueur d'onde caractéristique, c'est pourquoi on utilise une lampe à cathode creuse source composée de cet élément. La quantité d'énergie absorbée à la longueur d'onde caractéristique est proportionnelle à la concentration de l'élément dans l'échantillon.

30. Le logiciel AAS donne généralement des programmes électro-thermiques typiques pour chaque élément pour 10 µl d'échantillon dans du HNO₃ dilué (0, 1%) et des indications concernant les températures maximales d'incinération et d'atomisation. Des informations plus spécifiques peuvent également être trouvées dans la littérature, telles que les recommandations concernant les modificateurs de matrice et l'utilisation de tubes de séparation ou de tubes avec plate-forme. Lorsqu'un programme est optimisé pour la détermination d'un élément dans une matrice spécifique, toutes les informations doivent être consignées dans le journal des méthodes du laboratoire.

31. Pour certains éléments et certaines matrices, les résultats obtenus ne sont toujours pas satisfaisants (par exemple, la température maximale d'incinération n'est pas suffisante pour éliminer le fond), cette procédure doit être refaite avec l'ajout d'un modificateur de matrice. Différents modificateurs de matrice pourraient être essayés avant de trouver la meilleure solution.

32. Un protocole analytique détaillé pour l'analyse des métaux lourds dans les sédiments par GF AAS préparé par l'AIEA (2011c¹³) est présenté à l'annexe VIII (Méthode recommandée pour la détermination d'éléments traces sélectionnés dans des échantillons d'origine marine par spectrométrie d'absorption atomique utilisant du graphite fourneau).

33.

2.4 Protocole pour l'analyse des métaux lourds par ICP-MS

34. La spectroscopie de masse à couplage inductif (ICP-MS) est actuellement un instrument de pointe pour l'analyse des métaux, avec la possibilité de déterminer à des concentrations suivantes : µg L⁻¹ les concentrations d'un grand nombre d'éléments dans des échantillons de tissus de biote digérés par des acides. L'ICP-MS permet une analyse rapide et simultanée d'un large éventail de métaux lourds. La plupart des instruments de routine utilisent un spectromètre de masse quadripolaire, de sorte que la résolution de masse n'est pas assez élevée pour éviter le chevauchement des éléments à double charge ou des ions multi-éléments (principalement des hydrures, des oxydes et des hydroxydes) formés dans le plasma. La principale préoccupation concerne les interférences avec l'Ar, car le plasma est généralement un plasma d'argon, qui chevauche l'As. Certains éléments sont sujets à des effets de mémoire (en particulier le Hg) et nécessitent des précautions supplémentaires pour éviter les effets de report. Le logiciel des instruments modernes de l'ICP-MS comprend toutes les formules de réglage et de correction nécessaires et décrites ci-dessus pour effectuer l'analyse (HELCOM 2012a).

35. La méthode 200.8 (1994¹⁴) de l'EPA des États-Unis décrit une détermination multi-élémentaire des métaux lourds par ICP-MS dans l'eau et les échantillons solides après digestion acide.

¹³ IAEA (2011c) Recommended method for the determination of selected trace element in samples of marine origin by atomic absorption spectrometry using graphite furnace

¹⁴ US EPA (1994) US-EPA Method 200.8: Determination of trace elements in waters and wastes by inductively coupled plasma-mass spectrometry

La méthode était initialement destinée aux échantillons solides inorganiques (sols et sédiments) mais peut également être appliquée directement aux échantillons organiques. Selon Enamorado-Baez et al. (2015¹⁵), pour les tissus du biote, l'étape de digestion pourrait utiliser uniquement de l'acide nitrique (similaire à la méthode US-EPA 3051 établie pour les sédiments, les boues, les sols et les huiles) mais en augmentant le rapport masse d'échantillon/volume d'acide.

36. Les espèces de métaux provenant d'un liquide sont nébulisées et l'aérosol qui en résulte est transporté par le gaz argon dans la torche à plasma. Les ions produits par les hautes températures sont entraînés dans le gaz du plasma et introduits, par le biais d'une interface, dans un spectromètre de masse. Les ions produits dans le plasma sont triés en fonction de leur rapport masse/charge et quantifiés à l'aide d'un multiplicateur d'électrons à canaux. Les interférences doivent être évaluées et des corrections valables doivent être appliquées. La correction des interférences doit inclure la compensation des ions de fond apportés par le gaz du plasma, les réactifs et les constituants de la matrice de l'échantillon. La méthode US EPA 200.8 est présentée à l'Annexe X.

2.5. Protocole d'analyse du mercure total dans le biote marin avec décomposition thermique, amalgame et spectrophotométrie d'absorption atomique

37. Le mercure total dans le biote marin peut être analysé par un analyseur de mercure solide, qui a une sensibilité adéquate pour cette détermination. Une méthode détaillée décrivant le protocole pour la détermination du mercure total (inorganique et organique) dans les sédiments préparés par l'AIEA (2012a¹⁶) (« Méthode recommandée sur la détermination du mercure total dans les échantillons marins par décomposition thermique, amalgamation et spectrophotométrie d'absorption atomique » Annexe VI). Avec cette méthode, le Hg total est déterminé sans aucun prétraitement chimique de l'échantillon, minimisant ainsi la contamination possible et/ou les erreurs supplémentaires dues à la manipulation de l'échantillon. La méthode est basée sur la méthode US EPA 7473 (US EPA, 2007¹⁷).

38. L'échantillon est séché puis décomposé chimiquement sous oxygène dans le four de décomposition. Les produits de décomposition sont acheminés vers la section catalytique du four, où l'oxydation est terminée (les halogènes et les oxydes d'azote/soufre sont piégés). Le mercure présent dans les produits de décomposition restants est piégé sélectivement sur un amalgamateur. Après avoir rincé le système avec de l'oxygène, la vapeur de mercure est libérée par un chauffage rapide de l'amalgamateur et transportée à travers la cellule d'absorbance dans le trajet lumineux d'un spectrophotomètre d'absorption atomique à longueur d'onde unique. L'absorbance est mesurée à 253,7 nm en fonction de la quantité de mercure (ng). La plage de fonctionnement typique est de 0,1 à 500 ng. La vapeur de mercure est transportée à travers une cellule d'absorbance longue (première) et courte longueur de trajet. La même quantité de mercure est mesurée deux fois avec une sensibilité différente, ce qui donne une plage dynamique qui s'étend sur quatre ordres de grandeur. La limite de détection typique est de 0,01 ng de mercure.

2.6 Protocole d'analyse du Hg total dans des échantillons d'origine marine par CV-AAS

39. La méthode est largement utilisée pour la détermination du mercure total dans les tissus biologiques et elle est simple, rapide et applicable à un grand nombre d'échantillons environnementaux. La plage de travail typique est de 0,25-100 ng ml⁻¹ pour l'injection directe de vapeur froide, en utilisant le système « batch » (AIEA, 2012b). Analyse par spectrométrie d'absorption atomique à vapeur froide (CV-AAS) peut être effectuée manuellement à l'aide de CV-AAS par lots ou automatiquement à l'aide de techniques d'injection de flux (FIAS). La FIAS est une

¹⁵ Enamorado-Báez, S.M., Abril, JM and Gómez-Guzmán, JM (2013) Determination of 25 Trace Element Concentrations in Biological Reference Materials by ICP-MS following Different Microwave-Assisted Acid Digestion Methods Based on Scaling Masses of Digested Samples. Hindawi Publishing Corporation, ISRN Analytical Chemistry, Volume 2013, Article ID 851713, 14 pages. <http://dx.doi.org/10.1155/2013/851713>

¹⁶ IAEA (2012a) Recommended method on the determination of Total Hg in marine samples by Thermal Decomposition Amalgamation and Atomic Absorption Spectrometry

¹⁷ US EPA (2007). U.S. Environmental Protection Agency, EPA method 7473, Mercury in solids and solutions by thermal decomposition, amalgamation and atomic absorption spectrophotometry Rev 0. <http://www.epa.gov/osw/hazard/testmethods/sw846/pdfs/7473.pdf>

approche très efficace pour introduire et traiter des échantillons liquides en spectrométrie d'absorption atomique, elle réduit la consommation d'échantillons et de réactifs, et présente une plus grande tolérance aux interférences, des limites de détermination plus basses et une précision améliorée par rapport aux techniques classiques de vapeur froide (HELCOM, 2012b¹⁸).

40. Les échantillons de tissus du biote sont digérés avec des acides forts et le mercure inorganique est réduit à sa forme élémentaire avec du chlorure stanneux. La vapeur de mercure froide passe ensuite dans la cellule d'absorption à quartz d'un spectromètre d'absorption atomique (AAS), où sa concentration est mesurée.

41. Dans la méthode CV-AAS, le mercure inorganique est réduit à sa forme élémentaire avec du chlorure stanneux. La vapeur de mercure froide passe ensuite dans la cellule d'absorption à quartz d'un instrument AAS où sa concentration est mesurée. Le faisceau lumineux de la lampe à cathode creuse au Hg est dirigé à travers la cellule de quartz, dans un monochromateur et sur un détecteur qui mesure la quantité de lumière absorbée par la vapeur atomisée dans la cellule. La quantité d'énergie absorbée à la longueur d'onde caractéristique est proportionnelle à la concentration de l'élément dans l'échantillon.

42. Une méthode recommandée décrivant le protocole pour la détermination du mercure total dans les biotes préparés par l'AIEA (2012b¹⁹) est présentée à l'annexe VI (Méthode recommandée pour la détermination du Hg total dans les échantillons ou d'origine marine par spectrométrie d'absorption atomique à vapeur froide). Une méthode pour la détermination du Hg total dans le biote marin à l'aide de la CV-AAS est également suggérée par HELCOM (2012b) (Annexe VIII) et US EPA (2007b)²⁰.

3 Note technique pour l'analyse d'échantillons de tissus de fruits de mer pour la recherche de contaminants organiques

43. Les contaminants organiques réglementés comprennent les HAP (bézo(a)pyrène, benz(a)anthracène, benzo(b)fluoranthène et chrysène) (règlement (CE) n° 835/2011, annexe II), les dioxines, les PCB de type dioxine (règlement (CE) n° 1881/2006) (annexe I.) et les PCB non dioxines (PCB 28, PCB 52, PCB 101, PCB 138, PCB 153 et PCB 180) (règlement UE (CE) n° 1259/2011 (annexe V) L'analyse des quatre HAP et des 6 PCB non dioxines peut être effectuée conformément aux protocoles IMAP pertinents développés pour l'analyse des HAP et des PCB dans le biote marin, dans le cadre de la CI17. Cependant, le règlement (CE) n° 835/2011, qui a modifié le règlement (CE) n° 333/2007, ne fixe aucune teneur maximale pour les HAP dans les poissons frais, les crustacés ou les céphalopodes, et fixe une teneur maximale pour le bézo(a)pyrène et la somme de quatre HAP réglementés (Bézo(a)pyrène, benz(a)anthracène, benzo(b)fluoranthène et chrysène) uniquement pour les bivalves (frais, réfrigérés ou congelés).

44. L'analyse des dioxines et des PCB de type dioxine ne peut être effectuée que dans un laboratoire accrédité pour ce type d'analyse, en utilisant des méthodes appropriées telles que la chromatographie en phase gazeuse à haute résolution/spectrométrie de masse à haute résolution (HRGC/HRMS). L'échantillonnage et la préparation des échantillons pour cette analyse doivent respecter les exigences présentées dans le règlement (CE) n° 644/2017 de l'UE (annexe III).

45. Les méthodes d'analyse des PCB autres que les dioxines comprennent la chromatographie en phase gazeuse - détection par capture d'électrons (GC-ECD), la chromatographie en phase gazeuse - spectroscopie de masse à basse résolution (GC-LRMS), la chromatographie en phase gazeuse -

¹⁸ HELCOM (2012b). COMBINE Annex B-12, Appendix 4, Attachment 1. Technical note on the determination of Total Mercury in marine biota by Cold Vapour Atomic Absorption Spectroscopy

¹⁹ IAEA (2012b). Recommended method on the determination of Total Hg in samples of marine origin by Cold Vapour Atomic Absorption Spectrometry

²⁰ US EPA (2007b). U.S. Environmental Protection Agency, EPA method 7473, Mercury in solids and solutions by thermal decomposition, amalgamation and atomic absorption spectrophotometry Rev 0.
<http://www.epa.gov/osw/hazard/testmethods/sw846/pdfs/7473.pdf>

spectroscopie de masse en tandem (GC-MS/MS), la chromatographie en phase gazeuse - spectroscopie de masse à haute résolution (GC-HRMS) ou des méthodes équivalentes.

46. Les laboratoires nationaux peuvent décider d'utiliser toute méthode d'analyse validée qu'ils jugent appropriée et qui répond à des critères de performance spécifiques (LD, LOQ, précision, récupération et spécificité - Règlement (CE) n° 836/2011 de l'UE (annexe III.) et Règlement (CE) n° 644/2017 de l'UE (annexe IV).

Critères de performance des méthodes d'analyse pour les quatre HAP réglementés, (CE) n° 836/2011

Paramètre	Importance/observation
Applicabilité	Aliments spécifiés dans le règlement (CE) n° 1881/2006
LOD	Moins de 0,3 µg kg ⁻¹
LOQ	Moins de 0,9 µg kg ⁻¹
Précision	HORRAT _r ou HORRAT _R valeurs inférieures à 2 *
Récupération	50 à 120 %
Spécificité	Absence d'interférences matricielles ou spectrales, vérification de détection positive

* 'HORRAT_r' = La valeur RSDr observée divisée par la valeur de RSDr estimée à partir de l'équation d'Horwitz en utilisant l'hypothèse $r = 0,66R$. (M. Thompson, Analyst, 2000²¹, 125, 385-386.)

'HORRAT_R' = La valeur RSDR observée divisée par la valeur RSDR calculée à partir de l'équation d'Horwitz.

Critères de performance à respecter dans la fourchette de la teneur maximale pour la valeur TEQ respectivement la valeur BEQ, qu'elle soit déterminée comme TEQ total (équivalents toxiques) ou BEQ total (comme somme des PCDD/F et des PCB de type dioxine) ou séparément pour les PCDD/F et les PCB de type dioxine, (CE) n° 644/2017

	Dépistage par des méthodes bioanalytiques ou physico-chimiques	Méthodes de confirmation
Taux de faux résultat conforme(*)	< 5 %	
Exact		20 % à + 20 %
Répétabilité (RSDr)	< 20 %	
Précision intermédiaire (RSDR)	< 25 % < 15	< 25 % < 15

(*) En ce qui concerne les niveaux maximaux

Critères de performance pour la somme des PCB autres que les dioxines, (CE) n° 644/2017

	Spectrométrie de masse à dilution isotopique(*)	Autres techniques
Exact	- 20 à + 20 %	- 30 à + 30 %
Précision intermédiaire (RSDR)	≤ 15 %	≤ 20 %

²¹ Thomson, M. (2000). Tendances récentes de la précision interlaboratoire aux concentrations ppb et sous-ppb en relation avec les critères d'aptitude à l'emploi dans les essais d'aptitude. Analyst 125, 385-386

Différence entre le calcul de la limite supérieure et inférieure	$\leq 20 \%$	$\leq 20 \%$
--	--------------	--------------

(*) Utilisation des six analogues portant le label ^{13}C comme normes internes requises

47. Le laboratoire utilisé pour l'analyse des traces organiques doit être une installation spécialisée, isolée des autres projets qui pourraient être des sources de contamination. Il doit être correctement construit avec des hottes et des bancs munis de prises électriques qui ne présentent aucun danger pour l'utilisation de solvants inflammables. Le laboratoire doit disposer d'extracteurs et d'évaporateurs rotatifs refroidissant l'eau pour faire fonctionner les alambics. Dans les régions tropicales et dans les climats secs, un système de recirculation réfrigéré doit être utilisé pour réduire les températures aux niveaux requis et/ou pour conserver l'eau. L'acier inoxydable ou les carreaux de céramique constituent de bonnes surfaces non contaminantes. Si nécessaire, les bancs peuvent être recouverts d'une résine époxy dure et les murs peuvent être peints avec de la peinture époxy. Une feuille d'aluminium sur l'établi offre une surface qui peut être nettoyée avec un solvant. Il est essentiel de disposer d'une installation de stockage ventilée pour les solvants. Les bancs doivent être équipés de cadres pour maintenir les appareils fixes, les extracteurs, etc. L'interrupteur d'arrêt d'urgence doit être accessible de l'intérieur et de l'extérieur du laboratoire. Le matériel de lutte contre l'incendie doit être installé dans des endroits évidents et le personnel de laboratoire doit être formé à son utilisation.

48. Afin d'aider les laboratoires d'analyse des parties contractantes à la Convention de Barcelone, des protocoles IMAP sont proposés pour l'analyse des quatre HAP réglementés (Benzo(a)pyrène, benz(a)anthracène, benzo(b)fluoranthène et chrysène), des dioxines, des PCB de type dioxine et des PCB autres que ceux de type dioxine dans les échantillons de fruits de mer. Les laboratoires d'analyse doivent adapter, tester et modifier chaque étape des procédures présentées dans les protocoles afin de valider leurs résultats finaux. La liste des méthodes et du matériel d'analyse n'est pas exhaustive et les laboratoires sont encouragés à utiliser leur propre matériel/méthodes qu'ils jugent adéquats pour les analyses requises.

49. Dans le cadre de cette note technique, les présentes lignes directrices relatives à la préparation des échantillons et à l'analyse des produits de la mer comprennent les protocoles IMAP suivants pour l'analyse des composés organiques dans les échantillons du biote marin :

- Protocole pour l'analyse des dioxines et des PCB de type dioxine par chromatographie en phase gazeuse - spectrométrie de masse à haute résolution (GC-HRMS) ;
- Protocole pour l'analyse des PCB autres que les dioxines dans le biote marin à l'aide de la chromatographie en phase gazeuse et du détecteur à capture d'électrons (GC-ECD) ;
- Protocole pour l'analyse des PCB autres que les dioxines dans le biote marin par chromatographie en phase gazeuse - spectroscopie de masse (GC-MS) ;
- Protocole d'analyse des HAP dans le biote marin par Chromatographie Liquide Haute Performance – Fluorescence (HPLC-UVF) ;
- Protocole pour l'analyse des HAP dans le biote marin par chromatographie en phase gazeuse - spectrométrie de masse (GC-MS).

50. Ces protocoles sont basés sur des méthodes analytiques développées par le PNUE/AIEA (Annexe XIV : Méthodes de référence pour les études sur la pollution marine n° 71 pour l'analyse de certains hydrocarbures chlorés dans l'environnement marin), le programme HELCOM COMBINE (Annexe XV : Note technique sur la détermination des biphényles chlorés et des pesticides organochlorés dans le biote ; Annexe XVI : Note technique sur la détermination des hydrocarbures aromatiques polycycliques dans le biote), CIEM/OSPAR (Annexe XVII : Lignes directrices du CEMP pour la surveillance des contaminants dans le biote et les sédiments : Détermination des HAP parents et alkylés dans les matières biologiques) et l'US EPA (Annexe XVIII : US EPA Method 1613, Tetra-through octachlorinated dioxins and furanes by isotope dilution HRGC/HRMS ; Annexe XIX : US EPA Method 1668, Chlorinated biphenyl congeners in water, sol, sédiment, and tissu par HRGC/HRMS).

3.1 Protocole pour l'analyse des dioxines et des PCB de type dioxine par GC-HRMS

51. Les dibenzo-*p*-dioxines chlorées (dioxines) et les dibenzofuranes chlorés (furanes), ont des propriétés chimiques et des effets toxiques similaires, et sont généralement déterminés comme un seul groupe. Les PCB de type dioxine présentent également une toxicité élevée et sont inclus dans la liste des composés à déterminer dans les fruits de mer pour la protection de la santé des consommateurs. La dioxine la plus toxique est la 2,3,7,8-tétrachlorodibenzo-*p*-dioxine (2,3,7,8-TCDD), tandis que d'autres congénères présentent des degrés de toxicité différents (une liste avec les facteurs équivalents de toxicité de l'OMS pour l'évaluation des risques pour l'homme est présentée dans le règlement (CE) n° 1881/2006 de l'UE, Annexe I.) Les dioxines et les PCB de type dioxine sont présents en très faibles concentrations dans les fruits de mer, c'est pourquoi les méthodes d'analyse exigent des limites de détection en parties par billion (ppt: 10-12 g de 2,3,7,8-TCDD par g d'échantillon) ou en parties par quadrillion (ppq : 10⁻¹⁵ g 2,3,7,8-TCDD par g d'échantillon). Il est donc très important de séparer efficacement ces composés des autres contaminants organiques, dont les propriétés physiques et chimiques sont similaires, avant de les déterminer.

52. L'analyse des dioxines et des PCB de type dioxine dans les échantillons de fruits de mer implique une extraction de la matrice avec des solvants organiques, suivie d'un nettoyage, d'une séparation par chromatographie en phase gazeuse et d'une détection par GC-HRMS (Reiner et al, 2006²²): Les techniques d'extraction comprennent le Soxhlet, l'extraction liquide/liquide (US EPA 1994), l'extraction en phase solide (SPE) (Taylor et al, 1995²³), ou l'extraction par fluide sous pression (Richter et al 1994²⁴). Une fois que l'extrait a été transféré dans un solvant approprié, suit un nettoyage à colonne ouverte en trois étapes (silice, alumine et carbone). Les interférences des PCB peuvent être éliminées en analysant les extraits sur plusieurs colonnes (US EPA 2008²⁵ Méthode 1668). Un certain nombre de colonnes spécifiques à l'analyte peuvent être utilisées pour réduire les interférences des dioxines et des PCB et diminuer la nécessité d'une analyse multicolonne.

53. Les dioxines et les PCB de type dioxine sont généralement analysés par chromatographie en phase gazeuse à haute résolution - spectrométrie de masse à haute résolution (HRGC-HRMS) en utilisant la dilution isotopique (Petrovic et al 2002²⁶, Focant et al, 2005²⁷). Les méthodes d'analyse des dioxines et des PCB de type dioxine sont développées par l'US EPA (1994, 2008), la méthode ISO 18073 (2004²⁸), la méthode ISO 17585 (2006²⁹) et la norme européenne EN 1948 du Comité européen de normalisation EN 1948 (CEN, 1997³⁰). Un aperçu de la méthodologie d'extraction des échantillons, de nettoyage et d'analyse CG-MS, ainsi que du contrôle de la qualité des données et de la communication des données, est présenté dans l'article de Reiner et al (2006) : « Progrès dans les techniques d'analyse des dibenzo-*p*-dioxines polychlorées, des dibenzofuranes polychlorés et des PCB de type dioxine ». Les autres méthodes de détection des dioxines et des furanes comprennent la

²²Reiner, E.J, Clement, R.E, Okey, A.B., Marvin, C.H. (2006). Advances in analytical techniques for polychlorinated dibenzo-*p*-dioxins, polychlorinated dibenzofurans and dioxin-like PCBs. *Anal Bioanal Chem* (2006) 386: 791–806.

²³Taylor KZ, Waddell DS, Reiner EJ, MacPherson KA (1995). Direct Elution of Solid Phase Extraction Disks for the Determination of Polychlorinated Dibenzop-dioxins and Polychlorinated Dibenzofurans in Effluent Samples. *Analytical Chemistry*, 67:1186–1190

²⁴Richter B.E, Jones B.A, Ezzell J.L, Porter N.L, Avdalovic N, Pohl C (1996). Accelerated Solvent Extraction: A Technique for Sample Preparation. *Analytical Chemistry*, 68:1033–1039

²⁵US EPA (2008) Method 1668, Revision B: Chlorinated biphenyl congeners in water, soil, sediment, and tissue by HRGC/HRMS, EPA-821-R-08-020. Office of Water, US Environmental Protection Agency, Washington, DC (Annex XVI)

²⁶Petrovic M., Eljarrat E., Lopezde Alda M.J, Barcelo D. (2002). Recent advances in the mass spectrometric analysis related to endocrine disrupting compounds in aquatic environmental samples. *J. Chromatography A* 974:23–51.

²⁷Focant J.F, Pirard C, Eppe G, DePauw E. (2005). Recent advances in mass spectrometric measurement of dioxins J. *Chromatography A*. 1067:265–275

²⁸ISO (2004) ISO 18073: Water quality—Determination of tetratocta-chlorinated dioxins and furans—Method using isotope dilution HRGC/HRMS. International Organization for Standardization (ISO), Geneva, Switzerland

²⁹ISO (2006) ISO 17585: Water quality—Determination of dioxin-like polychlorinatedbiphenyls—method using gas chromatography and mass spectrometry. International Organization for Standardization (ISO), Geneva, Switzerland

³⁰CEN (1997) European Standard EN 1948: Stationary source emissions, determination of the mass concentration of PCDDs/PCDFs. CEN, Brussels, Belgium

spectrométrie de masse en tandem en tant qu'hybride/MS (Charles et al 1989³¹) et triple quadrupole MS/MS (Reiner et al, 1990³², 1991³³).

54. Des lignes directrices détaillées pour l'analyse des dioxines et des PCB de type dioxine au moyen de HRGC-HRMS sont proposées par la méthode 1613b (1994) (annexe XVIII) et la méthode 1668 (2008) (annexe XIX) de l'US EPA.

3.2 Protocole pour l'analyse des PCB autres que les dioxines dans les fruits de mer par GC-ECD

55. L'analyse des PCB autres que les dioxines dans les échantillons de fruits de mer implique une extraction de la matrice avec des solvants organiques, suivie d'un nettoyage et d'une séparation par chromatographie en phase gazeuse avec capture d'électrons (GC-ECD) ou détection par spectrométrie de masse (GC-MS). Pour réduire au minimum les erreurs systématiques dues à des conditions de chromatographie en phase gazeuse insuffisamment optimisées, à des pertes de déterminants (évaporation, rendement d'extraction insatisfaisant), et/ou à la contamination par des articles de laboratoire, des réactifs et l'environnement du laboratoire, il est essentiel que les sources d'erreurs systématiques soient identifiées et éliminées autant que possible (HELCOM, 2012c³⁴).

56. Pour l'analyse, les échantillons sont préparés pour l'extraction par solvant. Pour obtenir une récupération satisfaisante des hydrocarbures chlorés, les échantillons sont séchés soit par dessiccation avec du sulfate de sodium anhydre, soit par lyophilisation. Les lipides sont ensuite extraits par Soxhlet du biote à l'aide d'hexane ou d'éther de pétrole. Après les premiers traitements de nettoyage (traitement des extraits de biote avec de l'acide sulfurique concentré pour détruire certains lipides interférents), les extraits sont fractionnés par chromatographie sur colonne.

57. Tous les réactifs, y compris l'eau distillée, doivent être de qualité analytique. Les solvants disponibles dans le commerce comme l'acétone, l'acétonitrile, le dichlorométhane, l'hexane et le pentane sont invariablement contaminés par des substances actives pour les DPE ; leurs concentrations varient d'un lot à l'autre et selon le fournisseur. La qualité des réactifs doit être vérifiée par injection de 2 µl d'un lot de 100 ml de solvant, après concentration à 50 µl dans un évaporateur rotatif.

58. L'analyse quantitative avec le détecteur à capture d'électrons (ECD) est effectuée en comparant le signal du détecteur produit par l'échantillon avec celui de normes définies. En raison d'une séparation incomplète, plusieurs composés de coélution peuvent être présents sous un seul signal de détecteur, c'est pourquoi la forme et la taille du signal doivent être examinées de manière critique. Le temps de rétention relatif et la taille du signal doivent être confirmés sur des colonnes dont les phases stationnaires sont de polarité différente, ou par l'utilisation de techniques de GC multidimensionnelles. La GC doit être calibrée avant chaque lot de mesures. Comme le ECD a une courbe de réponse non linéaire, un étalonnage à plusieurs niveaux est fortement conseillé. Afin de déterminer les taux de récupération, un étalon interne approprié doit être ajouté à chaque échantillon au début de la procédure d'analyse (HELCOM, 2012c).

59. Une méthode étape par étape pour la détermination des polychlorobiphényles dans les échantillons biologiques par GC ECD est préparée par le PNUE/AIEA (2011d³⁵) (Annexe XIV),

³¹ Charles M.J, Green B., Tondeur J.R, Hass R. (1989). Optimisation of a hybrid-mass spectrometer method for the analysis of polychlorinated dibenzo-p-dioxins and polychlorinated dibenzofurans. *Chemosphere* 19, 51–57

³² Reiner E.J, Schellenberg D.H Taguchi V.Y, Mercer R.S, Townsend J.A, Thompson T.S, Clement R.E (1990). Application of tandem quadrupole mass spectrometry for ultra-trace determination of polychlorinated dibenzo-p-dioxins and dibenzofurans. *Chemosphere* 20, 1385-1392.

³³ Reiner E.J, Schellenberg D.H, Taguchi V.Y (1991). Environmental applications for the analysis of chlorinated dibenzo-p-dioxins and dibenzofurans using mass-spectrometry. *Environ Sci Technol* 25:110–117

³⁴ HELCOM (2012c). Manual for marine monitoring in the COMBINE programme. Annex B-12, Appendix 3. Technical note on the determination of chlorinated biphenyls and organochlorine pesticides in biota.

³⁵ UNEP/IAEA (2011). Sample work-up for the analysis of selected chlorinated hydrocarbons in the marine environment. Reference Methods for Marine Pollution Studies No 71.

comprenant la liste des réactifs, des solvants, des normes et des exemples pour la préparation de la solution mère, des solutions intermédiaires et des solutions de travail. Une méthode d'analyse des PCB dans les tissus des biotes par GC ECD est également proposée par HELCOM (2012c) (Annexe XV).

3.3 Protocole pour l'analyse des PCB autres que les dioxines dans les fruits de mer par GC-MS

60. L'analyse des PCB autres que les dioxines dans les échantillons de fruits de mer implique une extraction de la matrice avec des solvants organiques, suivie d'un nettoyage (comme présenté dans le protocole 3.2.), et d'une séparation par chromatographie en phase gazeuse avec détection par spectrométrie de masse (GC-MS).

61. L'analyse quantitative est réalisée en comparant le signal du détecteur produit par l'échantillon avec celui d'étalons définis, à l'aide d'un spectromètre de masse (SM). Souvent, en raison d'une séparation incomplète, plusieurs composés de coélution peuvent être présents sous un seul signal de détecteur. Par conséquent, la forme et la taille du signal doivent être examinées de manière critique. Avec un détecteur MS, la masse moléculaire ou les fragments de masse caractéristiques doivent être enregistrés à cette fin. La GC doit être calibrée avant chaque lot de mesures. Comme la MS a une courbe de réponse non linéaire, un étalonnage à plusieurs niveaux est conseillé. Afin de déterminer les taux de récupération, un étalon interne approprié doit être ajouté à chaque échantillon au début de la procédure d'analyse. L'étalon interne idéal est un PCB qui n'est pas présent dans l'échantillon et qui n'interfère pas avec d'autres PCB. Tous les congénères de PCB substitués en 2,4,6 sont, en principe, appropriés (HELCOM, 2012c).

62. Une méthode d'extraction, de concentration, de nettoyage et de fractionnement pour la détermination des PCB dans les échantillons biologiques est préparée par le PNUE/AIEA (2011d) (Annexe XIV). L'analyse des PCB peut être effectuée par GC-ECD suivie d'une confirmation par GC-MS. Une méthode d'analyse des PCB dans les tissus du biote par GC-MS est également proposée par HELCOM (2012c) (Annexe XV).

3.4 Protocole d'analyse des HAP dans les produits de la mer par HPLC – UVF

63. Les HAP émis par les processus de combustion sont principalement des composés parents (non substitués), tandis que les HAP provenant du pétrole et de ses sous-produits contiennent une gamme de composés alkylés en plus des HAP parents. Chromatographie liquide haute performance - Fluorescence (HPLC -UVF) a la capacité de déterminer les HAP parents mais n'a pas la sélectivité requise pour être utilisée pour la détermination des HAP alkylés. Cependant, ce n'est pas une limitation pour l'analyse des quatre HAP réglementés, qui sont des composés parents.

64. Les HAP sont lipophiles et donc concentrés dans les lipides d'un organisme, ils doivent donc être extraits par extraction Soxhlet, ou digestion alcaline suivie d'une extraction liquide-liquide avec un solvant organique. Pour l'extraction au Soxhlet, les tissus humides doivent être séchés en les mélangeant avec un agent chimique (par exemple, du sulfate de sodium anhydre). Les solvants non polaires seuls ne permettront pas d'extraire efficacement tous les HAP des tissus lors de l'utilisation de l'extraction Soxhlet, et des mélanges tels que l'hexane/dichlorométhane peuvent être efficaces. Les extraits de tissus contiendront toujours de nombreux composés autres que les HAP, et un nettoyage est nécessaire pour éliminer les composés qui peuvent interférer avec l'analyse ultérieure. Afin de réduire le volume de l'échantillon à 2 cm³, les solvants sont évaporés à l'aide d'un évaporateur à film rotatif à basse température (température du bain-marie de 30 °C ou moins) et dans des conditions de pression contrôlées. L'évaporation à sec doit être évitée. Lors de la réduction de l'échantillon au volume final, les solvants peuvent être éliminés par un flux d'azote gazeux propre. Les solvants et les matériaux adsorbants doivent tous être vérifiés pour la présence de HAP et d'autres composés

interférents. Si un tel composé est trouvé, les solvants, réactifs et matériaux d'adsorption doivent être purifiés ou nettoyés en utilisant des méthodes appropriées (HELCOM, 2012d³⁶, Annexe XVI).

65. Si l'extraction Soxhlet a été utilisée, les lipides résiduels doivent être éliminés avant la détermination analytique, avec une étape de nettoyage supplémentaire, en utilisant une chromatographie sur colonne avec de la silice et de l'alumine

66. Des lignes directrices pour la détermination des HAP dans les échantillons biologiques par HPLC – UVF sont préparées par HELCOM (2012d) (Annexe XVI.) et ICES/OSPAR (2018³⁷) (Annexe XVI).

3.5 Protocole d'analyse des HAP dans les produits de la mer par GC-MS

67. La méthode d'analyse GC-MS a la sélectivité suffisante pour déterminer la gamme complète des HAP, y compris les quatre contaminants réglementés (composés parent des HAP).

68. La procédure d'extraction est similaire à la procédure décrite pour la méthodologie HPLC-UVF, y compris l'extraction Soxhlet, ou digestion alcaline, suivie d'une extraction liquide-liquide avec un solvant organique. Alternativement, l'extraction d'échantillons humides ou secs de biote peut être effectuée par extraction liquide sous pression (PLE). Les extraits de tissus contiendront toujours de nombreux composés autres que les HAP, et un nettoyage est nécessaire pour éliminer les composés qui peuvent interférer avec l'analyse ultérieure. Les méthodes de nettoyage les plus couramment utilisées impliquent l'utilisation d'une chromatographie d'adsorption sur alumine ou silice désactivée. Lors de l'application du fractionnement, le schéma d'élution doit être vérifié fréquemment. Cela doit être effectué en présence de matrice d'échantillon, car cela peut désactiver partiellement la colonne de nettoyage, entraînant une élution des HAP plus précoce que dans une solution standard (ICES/OSPAR, 2018).

69. Après le nettoyage, les solvants sont évaporés à l'aide d'un évaporateur à film rotatif à basse température (température du bain-marie de 30 °C ou moins) et dans des conditions de pression contrôlées, et le volume de l'échantillon est réduit à environ 2 cm³. L'évaporation à sec doit être évitée. Lors de la réduction de l'échantillon au volume final, les solvants peuvent être éliminés par un flux d'azote gazeux propre. Les solvants et les matériaux adsorbants doivent tous être vérifiés pour la présence de HAP et d'autres composés interférents. Si de tels composés sont trouvés, les solvants, réactifs et matériaux adsorbants doivent être purifiés ou nettoyés en utilisant des méthodes appropriées.

70. La quantification est effectuée par GC-MS. Les deux modes d'injection couramment utilisés sont l'injection sans division et l'injection sur colonne. L'injection automatique d'échantillons doit être utilisée dans la mesure du possible pour améliorer la reproductibilité de l'injection et la précision de la méthode globale. Si l'injection sans division est utilisée, le revêtement doit être d'une capacité suffisante pour contenir le volume de solvant injecté après évaporation. Pour l'analyse des HAP, la propreté du revêtement est également très importante si l'on veut éviter les effets d'adsorption et la discrimination, et la colonne analytique ne doit pas contenir de sites actifs sur lesquels les HAP peuvent être adsorbés. L'hélium est le gaz vecteur préféré et seules des colonnes capillaires doivent être utilisées (HELCOM, 2012d, ICES/OSPAR 2018).

71. Des méthodes détaillées pour la détermination des HAP dans les échantillons biologiques par GC-MS sont proposées par HELCOM (2012d) (Annexe XVI) et ICES/OSPAR (2018) (Annexe XVII).

³⁶ HELCOM (2012d). Manual for marine monitoring in the COMBINE programme. Annex B-12, Appendix 2. Technical Note on the determination of Polycyclic Aromatic Hydrocarbons in Biota

³⁷ ICES/OSPAR (2018). CEMP Guidelines for monitoring contaminants in biota and sediments. Technical Annex 3: Determination of parent and alkylated PAHs in biological materials

Annex I

Official Journal of the European Union

**COMMISSION REGULATION (EC) No 1881/2006
of 19 December 2006
setting maximum levels for certain contaminants in foodstuffs**

COMMISSION REGULATION (EC) No 1881/2006
of 19 December 2006
setting maximum levels for certain contaminants in foodstuffs
 (Text with EEA relevance)

THE COMMISSION OF THE EUROPEAN COMMUNITIES,

Having regard to the Treaty establishing the European Community,

Having regard to Council Regulation (EEC) No 315/93 of 8 February 1993 laying down Community procedures for contaminants in food ⁽¹⁾, and in particular Article 2(3) thereof,

Whereas:

- (1) Commission Regulation (EC) No 466/2001 of 8 March 2001 setting maximum levels for certain contaminants in foodstuffs ⁽²⁾ has been amended substantially many times. It is necessary to amend again maximum levels for certain contaminants to take into account new information and developments in Codex Alimentarius. At the same time, the text should, where appropriate, be clarified. Regulation (EC) No 466/2001 should therefore be replaced.
- (2) It is essential, in order to protect public health, to keep contaminants at levels which are toxicologically acceptable.
- (3) In view of disparities between the laws of Member States and the consequent risk of distortion of competition, for some contaminants Community measures are necessary in order to ensure market unity while abiding by the principle of proportionality.
- (4) Maximum levels should be set at a strict level which is reasonably achievable by following good agricultural, fishery and manufacturing practices and taking into account the risk related to the consumption of the food. In the case of contaminants which are considered to be genotoxic carcinogens or in cases where current exposure of the population or of vulnerable groups in the population is close to or exceeds the tolerable intake, maximum levels should be set at a level which is as low as reasonably achievable (ALARA). Such approaches ensure that food business operators apply measures to prevent and reduce the contamination as far as possible in order to protect public health. It is furthermore appropriate for the health protection of infants and young children, a vulnerable group, to establish the lowest maximum levels, which are achievable through a strict selection of the raw materials used for the manufacturing of foods for infants and young children. This strict selection of the raw materials is also appropriate for the production of some specific foodstuffs such as bran for direct human consumption.
- (5) To allow maximum levels to be applied to dried, diluted, processed and compound foodstuffs, where no specific Community maximum levels have been established, food business operators should provide the specific concentration and dilution factors accompanied by the appropriate experimental data justifying the factor proposed.
- (6) To ensure an efficient protection of public health, products containing contaminants exceeding the maximum levels should not be placed on the market either as such, after mixture with other foodstuffs or used as an ingredient in other foods.
- (7) It is recognised that sorting or other physical treatments make it possible to reduce the aflatoxin content of consignments of groundnuts, nuts, dried fruit and maize. In order to minimise the effects on trade, it is appropriate to allow higher aflatoxin contents for those products which are not intended for direct human consumption or as an ingredient in foodstuffs. In these cases, the maximum levels for aflatoxins should be fixed taking into consideration the effectiveness of the above-mentioned treatments to reduce the aflatoxin content in groundnuts, nuts, dried fruit and maize to levels below the maximum limits fixed for those products intended for direct human consumption or use as an ingredient in foodstuffs.
- (8) To enable effective enforcement of the maximum levels for certain contaminants in certain foodstuffs, it is appropriate to provide for suitable labelling provisions for these cases.

⁽¹⁾ OJ L 37, 13.2.1993, p. 1. Regulation as amended by Regulation (EC) No 1882/2003 of the European Parliament and of the Council (OJ L 284, 31.10.2003, p. 1).

⁽²⁾ OJ L 77, 16.3.2001, p. 1. Regulation as last amended by Regulation (EC) No 199/2006 (OJ L 32, 4.2.2006, p. 32).

- (9) Because of the climatic conditions in some Member States, it is difficult to ensure that the maximum levels are not exceeded for fresh lettuce and fresh spinach. These Member States should be allowed for a temporary period to continue to authorise the marketing of fresh lettuce and fresh spinach grown and intended for consumption in their territory with nitrate contents exceeding the maximum levels. Lettuce and spinach producers established in the Member States which have given the aforementioned authorisations should progressively modify their farming methods by applying the good agricultural practices recommended at national level.
- (10) Certain fish species originating from the Baltic region may contain high levels of dioxins and dioxin-like PCBs. A significant proportion of these fish species from the Baltic region will not comply with the maximum levels and would therefore be excluded from the diet. There are indications that the exclusion of fish from the diet may have a negative health impact in the Baltic region.
- (11) Sweden and Finland have a system in place which has the capacity to ensure that consumers are fully informed of the dietary recommendations concerning restrictions on consumption of fish from the Baltic region by identified vulnerable groups of the population in order to avoid potential health risks. Therefore, it is appropriate to grant a derogation to Finland and Sweden to place on the market for a temporary period certain fish species originating in the Baltic region and intended for consumption in their territory with levels of dioxins and dioxin-like PCBs higher than those set in this Regulation. The necessary measures must be implemented to ensure that fish and fish products not complying with the maximum levels are not marketed in other Member States. Finland and Sweden report every year to the Commission the results of their monitoring of the levels of dioxins and dioxin-like PCBs in fish from the Baltic region and the measures to reduce human exposure to dioxins and dioxin-like PCBs from the Baltic region.
- (12) To ensure that the maximum levels are enforced in a uniform way, the same sampling criteria and the same analysis performance criteria should be applied by the competent authorities throughout the Community. It is furthermore important that analytical results are reported and interpreted in a uniform way. The measures as regards sampling and analysis specified in this Regulation provide for uniform rules on reporting and interpretation.
- (13) For certain contaminants, Member States and interested parties should monitor and report levels, as well report on the progress with regard to application of preventative measures, to allow the Commission to assess the need to modify existing measures or to adopt additional measures.
- (14) Any maximum level adopted at Community level can be subject to a review to take account of the advance of scientific and technical knowledge and improvements in good agricultural, fishery and manufacturing practices.
- (15) Bran and germ can be marketed for direct human consumption and it is therefore appropriate to establish a maximum level for deoxynivalenol and zearalenone in these commodities.
- (16) Codex Alimentarius has recently set a maximum level for lead in fish which the Community accepted. It is therefore appropriate to modify the current provision for lead in fish accordingly.
- (17) Regulation (EC) No 853/2004 of the European Parliament and Council of 29 April 2004 laying down specific hygiene rules for food of animal origin ⁽³⁾ defines foodstuffs of animal origin, and consequently the entries as regards foodstuffs of animal origin should be amended in some cases according to the terminology used in that Regulation.
- (18) It is necessary to provide that the maximum levels for contaminants do not apply to the foodstuffs which have been lawfully placed on the Community market before the date of application of these maximum levels.
- (19) As regards nitrate, vegetables are the major source for the human intake of nitrate. The Scientific Committee on Food (SCF) stated in its opinion of 22 September 1995 ⁽⁴⁾ that the total intake of nitrate is normally well below the acceptable daily intake (ADI) of 3,65 mg/kg body weight (bw). It recommended, however, continuation of efforts to reduce exposure to nitrate via food and water.
- (20) Since climatic conditions have a major influence on the levels of nitrate in certain vegetables such as lettuce and spinach, different maximum nitrate levels should therefore be fixed depending on the season.
- (13) For certain contaminants, Member States and interested parties should monitor and report levels, as well report on the progress with regard to application of pre-

⁽³⁾ OJ L 139, 30.4.2004, p. 55, as corrected by OJ L 226, 25.6.2004, p. 22. Regulation as last amended by Regulation (EC) No 1662/2006 (OJ L 320, 18.11.2006, p. 1).

⁽⁴⁾ Reports of the Scientific Committee for Food, 38th series, Opinion of the Scientific Committee for Food on nitrates and nitrite, p. 1, http://ec.europa.eu/food/fs/sc/scf/reports/scf_reports_38.pdf

- (21) As regards aflatoxins, the SCF expressed in its opinion of 23 September 1994 that aflatoxins are genotoxic carcinogens⁽⁵⁾. Based on that opinion, it is appropriate to limit the total aflatoxin content of food (sum of aflatoxins B₁, B₂, G₁ and G₂) as well as the aflatoxin B₁ content alone, aflatoxin B₁ being by far the most toxic compound. For aflatoxin M₁ in foods for infants and young children, a possible reduction of the current maximum level should be considered in the light of developments in analytical procedures.
- (22) As regards ochratoxin A (OTA), the SCF adopted a scientific opinion on 17 September 1998⁽⁶⁾. An assessment of the dietary intake of OTA by the population of the Community has been performed⁽⁷⁾ in the framework of Council Directive 93/5/EEC of 25 February 1993 on assistance to the Commission and cooperation by the Member States in the scientific examination of questions relating to food⁽⁸⁾ (SCOOP). The European Food Safety Authority (EFSA) has, on a request from the Commission, adopted an updated scientific opinion relating to ochratoxin A in food on 4 April 2006⁽⁹⁾, taking into account new scientific information and derived a tolerable weekly intake (TWI) of 120 ng/kg bw.
- (23) Based on these opinions, it is appropriate to set maximum levels for cereals, cereal products, dried vine fruit, roasted coffee, wine, grape juice and foods for infants and young children, all of which contribute significantly to general human exposure to OTA or to the exposure of vulnerable groups of consumers such as children.
- (24) The appropriateness of setting a maximum level for OTA in foodstuffs such as dried fruit other than dried vine fruit, cocoa and cocoa products, spices, meat products, green coffee, beer and liquorice, as well as a review of the existing maximum levels, in particular for OTA in dried vine fruit and grape juice, will be considered in the light of the recent EFSA scientific opinion.
- (25) As regards patulin, the SCF endorsed in its meeting on 8 March 2000 the provisional maximum tolerable daily intake (PMTDI) of 0,4 µg/kg bw for patulin⁽¹⁰⁾.
- (26) In 2001, a SCOOP-task 'Assessment of the dietary intake of patulin by the population of EU Member States' in the framework of Directive 93/5/EEC was performed⁽¹¹⁾.
- (27) Based on that assessment and taking into account the PMTDI, maximum levels should be set for patulin in certain foodstuffs to protect consumers from unacceptable contamination. These maximum levels should be reviewed and, if necessary, reduced taking into account the progress in scientific and technological knowledge and the implementation of Commission Recommendation 2003/598/EC of 11 August 2003 on the prevention and reduction of patulin contamination in apple juice and apple juice ingredients in other beverages⁽¹²⁾.
- (28) As regards Fusarium toxins, the SCF has adopted several opinions evaluating deoxynivalenol in December 1999⁽¹³⁾ establishing a tolerable daily intake (TDI) of 1 µg/kg bw, zearalenone in June 2000⁽¹⁴⁾ establishing a temporary TDI of 0,2 µg/kg bw, fumonisins in October 2000⁽¹⁵⁾ (updated in April 2003)⁽¹⁶⁾ establishing a TDI of 2 µg/kg bw, nivalenol in October 2000⁽¹⁷⁾ establishing a temporary TDI of 0,7 µg/kg bw, T-2 and HT-2 toxin in May 2001⁽¹⁸⁾ establishing a combined temporary TDI of 0,06 µg/kg bw and the trichothecenes as group in February 2002⁽¹⁹⁾.
-
- ⁽⁵⁾ Reports of the Scientific Committee for Food, 35th series, Opinion of the Scientific Committee for Food on aflatoxins, ochratoxin A and patulin, p. 45.
http://ec.europa.eu/food/fs/sc/scf/reports/scf_reports_35.pdf
- ⁽⁶⁾ Opinion of the Scientific Committee on Food on Ochratoxin A (expressed on 17 September 1998)
http://ec.europa.eu/food/fs/sc/scf/out14_en.html
- ⁽⁷⁾ Reports on tasks for scientific cooperation, Task 3.2.7 'Assessment of dietary intake of Ochratoxin A by the population of EU Member States'.
http://ec.europa.eu/food/food/chemicalsafety/contaminants/task_3-2-7_en.pdf
- ⁽⁸⁾ OJ L 52, 4.3.1993, p. 18.
- ⁽⁹⁾ Opinion of the Scientific Panel on contaminants in the Food Chain of the EFSA on a request from the Commission related to ochratoxin A in food. http://www.efsa.europa.eu/etc/medialib/efsa/science/contam/contam_opinions/1521.Par.0001.File.dat/contam_op_ej365_ochratoxin_a_food_en1.pdf
- ⁽¹⁰⁾ Minutes of the 120th Meeting of the Scientific Committee on Food held on 8 and 9 March 2000 in Brussels, Minute statement on patulin. http://ec.europa.eu/food/fs/sc/scf/out55_en.pdf
- ⁽¹¹⁾ Reports on tasks for scientific cooperation, Task 3.2.8, 'Assessment of dietary intake of Patulin by the population of EU Member States'.
http://ec.europa.eu/food/food/chemicalsafety/contaminants/3.2.8_en.pdf
- ⁽¹²⁾ OJ L 203, 12.8.2003, p. 34.
- ⁽¹³⁾ Opinion of the Scientific Committee on Food on Fusarium-toxins Part 1: Deoxynivalenol (DON), (expressed on 2 December 1999)
http://ec.europa.eu/food/fs/sc/scf/out44_en.pdf
- ⁽¹⁴⁾ Opinion of the Scientific Committee on Food on Fusarium-toxins Part 2: Zearalenone (ZEA), (expressed on 22 June 2000)
http://ec.europa.eu/food/fs/sc/scf/out65_en.pdf
- ⁽¹⁵⁾ Opinion of the Scientific Committee on Food on Fusarium-toxins Part 3: Fumonisin B₁ (FB₁) (expressed on 17 October 2000)
http://ec.europa.eu/food/fs/sc/scf/out73_en.pdf
- ⁽¹⁶⁾ Updated opinion of the Scientific Committee on Food on Fumonisin B₁, B₂ and B₃ (expressed on 4 April 2003)
http://ec.europa.eu/food/fs/sc/scf/out185_en.pdf
- ⁽¹⁷⁾ Opinion of the Scientific Committee on Food on Fusarium-toxins Part 4: Nivalenol (expressed on 19 October 2000)
http://ec.europa.eu/food/fs/sc/scf/out74_en.pdf
- ⁽¹⁸⁾ Opinion of the Scientific Committee on Food on Fusarium-toxins Part 5: T-2 toxin and HT-2 toxin (adopted on 30 May 2001)
http://ec.europa.eu/food/fs/sc/scf/out88_en.pdf
- ⁽¹⁹⁾ Opinion of the Scientific Committee on Food on Fusarium-toxins Part 6: Group evaluation of T-2 toxin, HT-2toxin, nivalenol and deoxynivalenol. (adopted on 26 February 2002)
http://ec.europa.eu/food/fs/sc/scf/out123_en.pdf

- (29) In the framework of Directive 93/5/EEC the SCOOP-task 'Collection of occurrence data on Fusarium toxins in food and assessment of dietary intake by the population of EU Member States' was performed and finalised in September 2003 ⁽²⁰⁾.
- (30) Based on the scientific opinions and the assessment of the dietary intake, it is appropriate to set maximum levels for deoxynivalenol, zearalenone and fumonisins. As regards fumonisins, monitoring control results of the recent harvests indicate that maize and maize products can be very highly contaminated by fumonisins and it is appropriate that measures are taken to avoid such unacceptably highly contaminated maize and maize products can enter the food chain.
- (31) Intake estimates indicate that the presence of T-2 and HT-2 toxin can be of concern for public health. Therefore, the development of a reliable and sensitive method, collection of more occurrence data and more investigations/research in the factors involved in the presence of T-2 and HT-2 toxin in cereals and cereal products, in particular in oats and oat products, is necessary and of high priority.
- (32) It is not necessary due to co-occurrence to consider specific measures for 3-acetyl deoxynivalenol, 15-acetyl deoxynivalenol and fumonisin B₃, as measures with regard to in particular deoxynivalenol and fumonisin B₁ and B₂ would also protect the human population from an unacceptable exposure from 3-acetyl deoxynivalenol, 15-acetyl deoxynivalenol and fumonisin B₃. The same applies to nivalenol for which to a certain degree co-occurrence with deoxynivalenol can be observed. Furthermore, human exposure to nivalenol is estimated to be significantly below the t-TDI. As regards other trichothecenes considered in the abovementioned SCOOP-task, such as 3-acetyldeoxynivalenol, 15-acetyldeoxynivalenol, fusarenon-X, T2-triol, diacetoxyscirpenol, neosolaniol, monoacetoxyscirpenol and verrucol, the limited information available indicates that they do not occur widely and the levels found are generally low.
- (33) Climatic conditions during the growth, in particular at flowering, have a major influence on the Fusarium toxin content. However, good agricultural practices, whereby the risk factors are reduced to a minimum, can prevent to a certain degree the contamination by *Fusarium* fungi. Commission Recommendation 2006/583/EC of 17 August 2006 on the prevention and reduction of Fusarium toxins in cereals and cereal products ⁽²¹⁾ contains general principles for the prevention and reduction of Fusarium toxin contamination (zearalenone, fumonisins and trichothecenes) in cereals to be implemented by the development of national codes of practice based on these principles.
- (34) Maximum levels of Fusarium toxins should be set for unprocessed cereals placed on the market for first-stage processing. Cleaning, sorting and drying procedures are not considered as first-stage processing insofar as no physical action is exerted on the grain kernel itself. Scouring is to be considered as first-stage processing.
- (35) Since the degree to which Fusarium toxins in unprocessed cereals are removed by cleaning and processing may vary, it is appropriate to set maximum levels for final consumer cereal products as well as for major food ingredients derived from cereals to have enforceable legislation in the interest of ensuring public health protection.
- (36) For maize, not all factors involved in the formation of Fusarium toxins, in particular zearalenone and fumonisins B₁ and B₂, are yet precisely known. Therefore, a time period is granted to enable food business operators in the cereal chain to perform investigations on the sources of the formation of these mycotoxins and on the identification of the management measures to be taken to prevent their presence as far as reasonably possible. Maximum levels based on currently available occurrence data are proposed to apply from 2007 in case no specific maximum levels based on new information on occurrence and formation are set before that time.
- (37) Given the low contamination levels of Fusarium toxins found in rice, no maximum levels are proposed for rice or rice products.
- (38) A review of the maximum levels for deoxynivalenol, zearalenone, fumonisin B₁ and B₂ as well as the appropriateness of setting a maximum level for T-2 and HT-2 toxin in cereals and cereal products should be considered by 1 July 2008, taking into account the progress in scientific and technological knowledge on these toxins in food.
- (39) As regards lead, the SCF adopted an opinion on 19 June 1992 ⁽²²⁾ endorsing the provisional tolerable weekly intake (PTWI) of 25 µg/kg bw proposed by the WHO in 1986. The SCF concluded in its opinion that the mean level in foodstuffs does not seem to be a cause of immediate concern.

⁽²⁰⁾ Reports on tasks for scientific cooperation, Task 3.2.10 'Collection of occurrence data of Fusarium toxins in food and assessment of dietary intake by the population of EU Member States'. <http://ec.europa.eu/food/fs/scoop/task3210.pdf>

⁽²¹⁾ OJ L 234, 29.8.2006, p. 35.

⁽²²⁾ Reports of the Scientific Committee for Food, 32nd series, Opinion of the Scientific Committee for Food on 'The potential risk to health presented by lead in food and drink', p. 7, http://ec.europa.eu/food/fs/sc/scf/reports/scf_reports_32.pdf

- (40) In the framework of Directive 93/5/EEC 2004 the SCOOP-task 3.2.11 'Assessment of the dietary exposure to arsenic, cadmium, lead and mercury of the population of the EU Member States' was performed in 2004⁽²³⁾. In view of this assessment and the opinion delivered by the SCF, it is appropriate to take measures to reduce the presence of lead in food as much as possible
- (41) As regards cadmium, the SCF endorsed in its opinion of 2 June 1995⁽²⁴⁾ the PTWI of 7 µg/kg bw and recommended greater efforts to reduce dietary exposure to cadmium since foodstuffs are the main source of human intake of cadmium. A dietary exposure assessment was performed in the SCOOP-task 3.2.11. In view of this assessment and the opinion delivered by the SCF, it is appropriate to take measures to reduce the presence of cadmium in food as much as possible.
- (42) As regards mercury EFSA adopted on 24 February 2004 an opinion related to mercury and methylmercury in food⁽²⁵⁾ and endorsed the provisional tolerable weekly intake of 1,6 µg/kg bw. Methylmercury is the chemical form of most concern and can make up more than 90 % of the total mercury in fish and seafood. Taking into account the outcome of the SCOOP-task 3.2.11, EFSA concluded that the levels of mercury found in foods, other than fish and seafood, were of lower concern. The forms of mercury present in these other foods are mainly not methylmercury and they are therefore considered to be of lower risk.
- (43) In addition to the setting of maximum levels, targeted consumer advice is an appropriate approach in the case of methylmercury for protecting vulnerable groups of the population. An information note on methylmercury in fish and fishery products responding to this need has therefore been made available on the website of the Health and Consumer Protection Directorate-General of the European Commission⁽²⁶⁾. Several Member States have also issued advice on this issue that is relevant to their population.
- (44) As regards inorganic tin, the SCF concluded in its opinion of 12 December 2001⁽²⁷⁾ that levels of inorganic tin of 150 mg/kg in canned beverages and 250 mg/kg in other canned foods may cause gastric irritation in some individuals.
- (45) To protect public health from this health risk it is necessary to set maximum levels for inorganic tin in canned foods and canned beverages. Until data becomes available on the sensitivity of infants and young children to inorganic tin in foods, it is necessary on a precautionary basis to protect the health of this vulnerable population group and to establish lower maximum levels.
- (46) As regards 3-monochloropropane-1,2-diol (3-MCPD) the SCF adopted on 30 May 2001 a scientific opinion as regards 3-MCPD in food⁽²⁸⁾, updating its opinion of 16 December 1994⁽²⁹⁾ on the basis of new scientific information and established a tolerable daily intake (TDI) of 2 µg/kg bw for 3-MCPD.
- (47) In the framework of Directive 93/5/EEC the SCOOP-task 'Collection and collation of data on levels of 3-MCPD and related substances in foodstuffs' was performed and finalised in June 2004⁽³⁰⁾. The main contributors of 3-MCPD to dietary intake were soy sauce and soy-sauce based products. Some other foods eaten in large quantities, such as bread and noodles, also contributed significantly to intake in some countries because of high consumption rather than high levels of 3-MCPD present in these foods.
- (48) Accordingly maximum levels should be set for 3-MCPD in hydrolysed vegetable protein (HVP) and soy sauce taking into account the risk related to the consumption of these foods. Member States are requested to examine other foodstuffs for the occurrence of 3-MCPD in order to consider the need to set maximum levels for additional foodstuffs.

⁽²³⁾ Reports on tasks for scientific co-operation, Task 3.2.11 'Assessment of dietary exposure to arsenic, cadmium, lead and mercury of the population of the EU Member States'. http://ec.europa.eu/food/food/chemicalsafety/contaminants/scoop_3-2-11_heavy_metals_report_en.pdf

⁽²⁴⁾ Reports of the Scientific Committee for Food, 36th series, Opinion of the Scientific Committee for Food on cadmium, p. 67, http://ec.europa.eu/food/fs/sc/scf/reports/scf_reports_36.pdf

⁽²⁵⁾ Opinion of the Scientific Panel on contaminants in the Food Chain of the European Food Safety Authority (EFSA) on a request from the Commission related to mercury and methylmercury in food (adopted on 24 February 2004) http://www.efsa.eu.int/science/contam/contam_opinions/259/opinion_contam_01_en1.pdf

⁽²⁶⁾ http://ec.europa.eu/food/food/chemicalsafety/contaminants/information_note_mercury-fish_12-05-04.pdf

⁽²⁷⁾ Opinion of the Scientific Committee on Food on acute risks posed by tin in canned foods (adopted on 12 December 2001) http://ec.europa.eu/food/fs/sc/scf/out110_en.pdf

⁽²⁸⁾ Opinion of the Scientific Committee on Food on 3-monochloropropane-1,2-diol (3-MCPD) updating the SCF opinion of 1994 (adopted on 30 May 2001) http://ec.europa.eu/food/fs/sc/scf/out91_en.pdf

⁽²⁹⁾ Reports of the Scientific Committee for Food, 36th series, Opinion of the Scientific Committee for Food on 3-monochloropropane-1,2-diol 3-MCPD, p. 31, http://ec.europa.eu/food/fs/sc/scf/reports/scf_reports_36.pdf

⁽³⁰⁾ Reports on tasks for scientific cooperation, Task 3.2.9 'Collection and collation of data on levels of 3-monochloropropanediol (3-MCPD) and related substances in foodstuffs'. http://ec.europa.eu/food/food/chemicalsafety/contaminants/scoop_3-2-9_final_report_chloropropanols_en.pdf

- (49) As regards dioxins and PCBs, the SCF adopted on 30 May 2001 an opinion on dioxins and dioxin-like PCBs in food ⁽³¹⁾, updating its opinion of 22 November 2000 ⁽³²⁾ fixing a tolerable weekly intake (TWI) of 14 pg World Health Organisation toxic equivalent (WHO-TEQ)/kg bw for dioxins and dioxin-like PCBs.
- (50) Dioxins as referred to in this Regulation cover a group of 75 polychlorinated dibenzo-p-dioxin (PCDD) congeners and 135 polychlorinated dibenzofuran (PCDF) congeners, of which 17 are of toxicological concern. Polychlorinated biphenyls (PCBs) are a group of 209 different congeners which can be divided into two groups according to their toxicological properties: 12 congeners exhibit toxicological properties similar to dioxins and are therefore often termed dioxin-like PCBs. The other PCBs do not exhibit dioxin-like toxicity but have a different toxicological profile.
- (51) Each congener of dioxins or dioxin-like PCBs exhibits a different level of toxicity. In order to be able to sum up the toxicity of these different congeners, the concept of toxic equivalency factors (TEFs) has been introduced to facilitate risk assessment and regulatory control. This means that the analytical results relating to all the individual dioxin and dioxin-like PCB congeners of toxicological concern are expressed in terms of a quantifiable unit, namely the TCDD toxic equivalent (TEQ).
- (52) Exposure estimates taking into account the SCOOP-task 'Assessment of dietary intake of dioxins and related PCBs by the population of EU Member States' finalised in June 2000 ⁽³³⁾ indicate that a considerable proportion of the Community population has a dietary intake in excess of the TWI.
- (53) From a toxicological point of view, any level set should apply to both dioxins and dioxin-like PCBs, but in 2001 maximum levels were set on Community level only for dioxins and not for dioxin-like PCBs, given the very limited data available at that time on the prevalence of dioxin-like PCBs. Since 2001, however, more data on the presence of dioxin-like PCBs have become available, therefore, maximum levels for the sum of dioxins and dioxin-like PCBs have been set in 2006 as this is the most appropriate approach from a toxicological point of view. In order to ensure a smooth transition, the levels for dioxins should continue to apply for a transitional period in addition to the levels for the sum of dioxins and dioxin-like PCBs. Foodstuffs must comply during that transitional period with the maximum levels for dioxins and with the maximum levels for the sum of dioxins and dioxin-like PCBs. Consideration will be given by 31 December 2008 to dispensing with the separate maximum levels for dioxins.
- (54) In order to encourage a proactive approach to reducing the dioxins and dioxin-like PCBs present in food and feed, action levels were set by Commission Recommendation 2006/88/EC of 6 February 2006 on the reduction of the presence of dioxins, furans and PCBs in feeding-stuffs and foodstuffs ⁽³⁴⁾. These action levels are a tool for competent authorities and operators to highlight those cases where it is appropriate to identify a source of contamination and to take measures to reduce or eliminate it. Since the sources of dioxins and dioxin-like PCBs are different, separate action levels are determined for dioxins on the one hand and for dioxin-like PCBs on the other hand. This proactive approach to actively reduce the dioxins and dioxin-like PCBs in feed and food and consequently, the maximum levels applicable should be reviewed within a defined period of time with the objective to set lower levels. Therefore, consideration will be given by 31 December 2008 to significantly reducing the maximum levels for the sum of dioxins and dioxin-like PCBs.
- (55) Operators need to make efforts to step up their capacity to remove dioxins, furans and dioxin-like PCBs from marine oil. The significant lower level, to which consideration shall be given by 31 December 2008, shall be based on the technical possibilities of the most effective decontamination procedure.
- (56) As regards the establishment of maximum levels for other foodstuffs by 31 December 2008, particular attention shall be paid to the need to set specific lower maximum levels for dioxins and dioxin-like PCBs in foods for infants and young children in the light of the monitoring data obtained through the 2005, 2006 and 2007 programmes for monitoring dioxins and dioxin-like PCBs in foods for infants and young children.

⁽³¹⁾ Opinion of the Scientific Committee on Food on the risk assessment of dioxins and dioxin-like PCBs in food. Update based on new scientific information available since the adoption of the SCF opinion of 22nd November 2000 (adopted on 30 May 2001) http://ec.europa.eu/food/fs/sc/scf/out90_en.pdf

⁽³²⁾ Opinion of the Scientific Committee on Food on the risk assessment of dioxins and dioxin-like PCBs in food. (adopted on 22 November 2000) http://ec.europa.eu/food/fs/sc/scf/out78_en.pdf

⁽³³⁾ Reports on tasks for scientific cooperation, Task 3.2.5 'Assessment of dietary intake of dioxins and related PCBs by the population of EU Member States'. http://ec.europa.eu/dgs/health_consumer/library/pub/pub08_en.pdf

⁽³⁴⁾ OJ L 42, 14.2.2006, p. 26.

- (57) As regards polycyclic aromatic hydrocarbons, the SCF concluded in its opinion of 4 December 2002⁽³⁵⁾ that a number of polycyclic aromatic hydrocarbons (PAH) are genotoxic carcinogens. The Joint FAO/WHO Expert Committee on Food Additives (JECFA) performed in 2005 a risk assessment on PAHs and estimated margins of exposure (MOE) for PAH as a basis for advice on compounds that are both genotoxic and carcinogenic⁽³⁶⁾.
- (58) According to the SCF, benzo(a)pyrene can be used as a marker for the occurrence and effect of carcinogenic PAH in food, including also benz(a)anthracene, benzo(b)fluoranthene, benzo(j)fluoranthene, benzo(k)fluoranthene, benzo(g,h,i)perylene, chrysene, cyclopenta(c,d)pyrene, dibenz(a,h)anthracene, dibenzo(a,e)pyrene, dibenzo(a,h)pyrene, dibenzo(a,i)pyrene, dibenzo(a,l)pyrene, indeno(1,2,3-cd)pyrene and 5-methylchrysene. Further analyses of the relative proportions of these PAH in foods would be necessary to inform a future review of the suitability of maintaining benzo(a)pyrene as a marker. In addition benzo(c)fluorene should be analysed, following a recommendation of JECFA.
- (59) PAH can contaminate foods during smoking processes and heating and drying processes that allow combustion products to come into direct contact with food. In addition, environmental pollution may cause contamination with PAH, in particular in fish and fishery products.
- (60) In the framework of Directive 93/5/EEC, a specific SCOOP-task 'Collection of occurrence data on PAH in food' has been performed in 2004⁽³⁷⁾. High levels were found in dried fruits, olive pomace oil, smoked fish, grape seed oil, smoked meat products, fresh molluscs, spices/sauces and condiments.
- (61) In order to protect public health, maximum levels are necessary for benzo(a)pyrene in certain foods containing fats and oils and in foods where smoking or drying processes might cause high levels of contamination. Maximum levels are also necessary in foods where environmental pollution may cause high levels of contamination, in particular in fish and fishery products, for example resulting from oil spills caused by shipping.
- (62) In some foods, such as dried fruit and food supplements, benzo(a)pyrene has been found, but available data are inconclusive on what levels are reasonably achievable. Further investigation is needed to clarify the levels that are reasonably achievable in these foods. In the meantime, maximum levels for benzo(a)pyrene in relevant ingredients should apply, such as in oils and fats used in food supplements.
- (63) The maximum levels for PAH and the appropriateness of setting a maximum level for PAH in cocoa butter should be reviewed by 1 April 2007, taking into account the progress in scientific and technological knowledge on the occurrence of benzo(a)pyrene and other carcinogenic PAH in food.
- (64) The measures provided for in this Regulation are in accordance with the opinion of the Standing Committee on the Food Chain and Animal Health,

HAS ADOPTED THIS REGULATION:

Article 1

General rules

1. The foodstuffs listed in the Annex shall not be placed on the market where they contain a contaminant listed in the Annex at a level exceeding the maximum level set out in the Annex.
2. The maximum levels specified in the Annex shall apply to the edible part of the foodstuffs concerned, unless otherwise specified in the Annex.

Article 2

Dried, diluted, processed and compound foodstuffs

1. When applying the maximum levels set out in the Annex to foodstuffs which are dried, diluted, processed or composed of more than one ingredient, the following shall be taken into account:
 - (a) changes of the concentration of the contaminant caused by drying or dilution processes;
 - (b) changes of the concentration of the contaminant caused by processing;
 - (c) the relative proportions of the ingredients in the product;
 - (d) the analytical limit of quantification.

⁽³⁵⁾ Opinion of the Scientific Committee on Food on the risks to human health of Polycyclic Aromatic Hydrocarbons in food (expressed on 4 December 2002)

http://ec.europa.eu/food/fs/sc/scf/out153_en.pdf

⁽³⁶⁾ Evaluation of certain food contaminants — Report of the Joint FAO/WHO Expert Committee on Food Additives, 64th meeting, Rome, 8 to 17 February 2005, p. 1 and p. 61.

WHO Technical Report Series, No. 930, 2006 — http://whqlibdoc.who.int/trs/WHO_TRS_930_eng.pdf

⁽³⁷⁾ Reports on tasks for scientific co-operation, Task 3.2.12 'Collection of occurrence data on polycyclic aromatic hydrocarbons in food'. http://ec.europa.eu/food/food/chemicalsafety/contaminants/scoop_3-2-12_final_report_pah_en.pdf

2. The specific concentration or dilution factors for the drying, dilution, processing and/or mixing operations concerned or for the dried, diluted, processed and/or compound foodstuffs concerned shall be provided and justified by the food business operator, when the competent authority carries out an official control.

If the food business operator does not provide the necessary concentration or dilution factor or if the competent authority deems that factor inappropriate in view of the justification given, the authority shall itself define that factor, based on the available information and with the objective of maximum protection of human health.

3. Paragraphs 1 and 2 shall apply in so far as no specific Community maximum levels are fixed for these dried, diluted, processed or compound foodstuffs.

4. As far as Community legislation does not provide for specific maximum levels for foods for infants and young children, Member States may provide for stricter levels.

Article 3

Prohibitions on use, mixing and detoxification

1. Foodstuffs not complying with the maximum levels set out in the Annex shall not be used as food ingredients.

2. Foodstuffs complying with the maximum levels set out in the Annex shall not be mixed with foodstuffs which exceed these maximum levels.

3. Foodstuffs to be subjected to sorting or other physical treatment to reduce contamination levels shall not be mixed with foodstuffs intended for direct human consumption or with foodstuffs intended for use as a food ingredient.

4. Foodstuffs containing contaminants listed in section 2 of the Annex (Mycotoxins) shall not be deliberately detoxified by chemical treatments.

Article 4

Specific provisions for groundnuts, nuts, dried fruit and maize

Groundnuts, nuts, dried fruit and maize not complying with the appropriate maximum levels of aflatoxins laid down in points 2.1.3, 2.1.5 and 2.1.6 of the Annex can be placed on the market provided that these foodstuffs:

- (a) are not intended for direct human consumption or use as an ingredient in foodstuffs;
- (b) comply with the appropriate maximum levels laid down in points 2.1.1, 2.1.2, 2.1.4 and 2.1.7 of the Annex;
- (c) are subjected to a treatment involving sorting or other physical treatment and that after this treatment the maximum levels laid down in points 2.1.3, 2.1.5 and 2.1.6 of the Annex are not exceeded, and this treatment does not result in other harmful residues;
- (d) are labelled clearly showing their use, and bearing the indication 'product shall be subjected to sorting or other physical treatment to reduce aflatoxin contamination before human consumption or use as an ingredient in foodstuffs'. The indication shall be included on the label of each individual bag, box etc. or on the original accompanying document. The consignment/batch identification code shall be indelibly marked on each individual bag, box etc. of the consignment and on the original accompanying document.

Article 5

Specific provisions for groundnuts, derived products thereof and cereals

A clear indication of the intended use must appear on the label of each individual bag, box, etc. or on the original accompanying document. This accompanying document must have a clear link with the consignment by means of mentioning the consignment identification code, which is on each individual bag, box, etc. of the consignment. In addition the business activity of the consignee of the consignment given on the accompanying document must be compatible with the intended use.

In the absence of a clear indication that their intended use is not for human consumption, the maximum levels laid down in points 2.1.3 and 2.1.6 of the Annex shall apply to all groundnuts, derived products thereof and cereals placed on the market.

Article 6

Specific provisions for lettuce

Unless lettuce grown under cover (protected lettuce) is labelled as such, maximum levels set in the Annex for lettuce grown in the open air (open-grown lettuce) shall apply.

*Article 7***Temporary derogations**

1. By way of derogation from Article 1, Belgium, Ireland, the Netherlands and the United Kingdom may authorise until 31 December 2008 the placing on the market of fresh spinach grown and intended for consumption in their territory with nitrate levels higher than the maximum levels set out in point 1.1 of the Annex.

2. By way of derogation from Article 1, Ireland and the United Kingdom may authorise until 31 December 2008 the placing on the market of fresh lettuce grown and intended for consumption in their territory and harvested throughout the year with nitrate levels higher than the maximum levels set out in point 1.3 of the Annex.

3. By way of derogation from Article 1, France may authorise until 31 December 2008 the placing on the market of fresh lettuce grown and intended for consumption in its territory and harvested from 1 October to 31 March with nitrate levels higher than the maximum levels set out in point 1.3 of the Annex.

4. By way of derogation from Article 1, Finland and Sweden may authorise until 31 December 2011 the placing on their market of salmon (*Salmo salar*), herring (*Clupea harengus*), river lamprey (*Lampetra fluviatilis*), trout (*Salmo trutta*), char (*Salvelinus* spp.) and roe of vendace (*Coregonus albula*) originating in the Baltic region and intended for consumption in their territory with levels of dioxins and/or levels of the sum of dioxins and dioxin-like PCBs higher than those set out in point 5.3 of the Annex, provided that a system is in place to ensure that consumers are fully informed of the dietary recommendations with regard to the restrictions on the consumption of these fish species from the Baltic region by identified vulnerable sections of the population in order to avoid potential health risks. By 31 March each year, Finland and Sweden shall communicate to the Commission the results of their monitoring of the levels of dioxins and dioxin-like PCBs in fish from the Baltic region obtained in the preceding year and shall report on the measures taken to reduce human exposure to dioxins and dioxin-like PCBs from fish from the Baltic region.

Finland and Sweden shall continue to apply the necessary measures to ensure that fish and fish products not complying with point 5.3 of the Annex are not marketed in other Member States.

*Article 8***Sampling and analysis**

The sampling and the analysis for the official control of the maximum levels specified in the Annex shall be performed in accordance with Commission Regulations (EC) No

1882/2006⁽³⁸⁾, No 401/2006⁽³⁹⁾, No 1883/2006⁽⁴⁰⁾ and Commission Directives 2001/22/EC⁽⁴¹⁾, 2004/16/EC⁽⁴²⁾ and 2005/10/EC⁽⁴³⁾.

*Article 9***Monitoring and reporting**

1. Member States shall monitor nitrate levels in vegetables which may contain significant levels, in particular green leaf vegetables, and communicate the results to the Commission by 30 June each year. The Commission will make these results available to the Member States.

2. Member States and interested parties shall communicate each year to the Commission the results of investigations undertaken including occurrence data and the progress with regard to the application of prevention measures to avoid contamination by ochratoxin A, deoxynivalenol, zearalenone, fumonisin B₁ and B₂, T-2 and HT-2 toxin. The Commission will make these results available to the Member States.

3. Member States should report to the Commission findings on aflatoxins, dioxins, dioxin-like PCBs, non-dioxin-like PCBs and polycyclic aromatic hydrocarbons as specified in Commission Decision 2006/504/EC⁽⁴⁴⁾, Commission Recommendation 2006/794/EC⁽⁴⁵⁾ and Commission Recommendation 2005/108/EC⁽⁴⁶⁾.

*Article 10***Repeal**

Regulation (EC) No 466/2001 is repealed.

References to the repealed Regulation shall be construed as references to this Regulation.

*Article 11***Transitional measures**

This Regulation shall not apply to products that were placed on the market before the dates referred to in points (a) to (d) in conformity with the provisions applicable at the respective date:

- (a) 1 July 2006 as regards the maximum levels for deoxynivalenol and zearalenone laid down in points 2.4.1, 2.4.2, 2.4.4, 2.4.5, 2.4.6, 2.4.7, 2.5.1, 2.5.3, 2.5.5 and 2.5.7 of the Annex;

⁽³⁸⁾ See page 25 of this Official Journal.

⁽³⁹⁾ OJ L 70, 9.3.2006, p. 12.

⁽⁴⁰⁾ See page 32 of this Official Journal.

⁽⁴¹⁾ OJ L 77, 16.3.2001, p. 14. Directive as amended by Directive 2005/4/EC (OJ L 19, 21.1.2005, p. 50).

⁽⁴²⁾ OJ L 42, 13.2.2004, p. 16.

⁽⁴³⁾ OJ L 34, 8.2.2005, p. 15.

⁽⁴⁴⁾ OJ L 199, 21.7.2006, p. 21.

⁽⁴⁵⁾ OJ L 322, 22.11.2006, p. 24.

⁽⁴⁶⁾ OJ L 34, 8.2.2005, p. 43.

(b) 1 July 2007 as regards the maximum levels for deoxyvalenol and zearalenone laid down in points 2.4.3, 2.5.2, 2.5.4, 2.5.6 and 2.5.8 of the Annex;

(c) 1 October 2007 as regards the maximum levels for fumonisins B₁ and B₂ laid down in point 2.6 of the Annex;

(d) 4 November 2006 as regards the maximum levels for the sum of dioxins and dioxin-like PCBs laid down in section 5 of the Annex.

The burden of proving when the products were placed on the market shall be borne by the food business operator.

Article 12

Entry into force and application

This Regulation shall enter into force on the 20th day following its publication in the *Official Journal of the European Union*.

It shall apply from 1 March 2007.

This Regulation shall be binding in its entirety and directly applicable in all Member States.

Done at Brussels, 19 December 2006.

For the Commission
Markos KYPRIANOU
Member of the Commission

ANNEX

Maximum levels for certain contaminants in foodstuffs ⁽¹⁾

Section 1: Nitrate

Foodstuffs ⁽¹⁾		Maximum levels (mg NO ₃ /kg)	
1.1	Fresh spinach (<i>Spinacia oleracea</i>) ⁽²⁾	Harvested 1 October to 31 March	3 000
		Harvested 1 April to 30 September	2 500
1.2	Preserved, deep-frozen or frozen spinach		2 000
1.3	Fresh Lettuce (<i>Lactuca sativa</i> L.) (protected and open-grown lettuce) excluding lettuce listed in point 1.4	Harvested 1 October to 31 March: lettuce grown under cover	4 500
		lettuce grown in the open air	4 000
		Harvested 1 April to 30 September: lettuce grown under cover	3 500
		lettuce grown in the open air	2 500
1.4	Iceberg-type lettuce	Lettuce grown under cover	2 500
		Lettuce grown in the open air	2 000
1.5	Processed cereal-based foods and baby foods for infants and young children ⁽³⁾ ⁽⁴⁾		200

Section 2: Mycotoxins

Foodstuffs ⁽¹⁾		Maximum levels (µg/kg)		
2.1	Aflatoxins	B ₁	Sum of B ₁ , B ₂ , G ₁ and G ₂	M ₁
2.1.1	Groundnuts to be subjected to sorting, or other physical treatment, before human consumption or use as an ingredient in foodstuffs	8,0 ⁽⁵⁾	15,0 ⁽⁵⁾	—
2.1.2	Nuts to be subjected to sorting, or other physical treatment, before human consumption or use as an ingredient in foodstuffs	5,0 ⁽⁵⁾	10,0 ⁽⁵⁾	—
2.1.3	Groundnuts and nuts and processed products thereof, intended for direct human consumption or use as an ingredient in foodstuffs	2,0 ⁽⁵⁾	4,0 ⁽⁵⁾	—
2.1.4	Dried fruit to be subjected to sorting, or other physical treatment, before human consumption or use as an ingredient in foodstuffs	5,0	10,0	—
2.1.5	Dried fruit and processed products thereof, intended for direct human consumption or use as an ingredient in foodstuffs	2,0	4,0	—
2.1.6	All cereals and all products derived from cereals, including processed cereal products, with the exception of foodstuffs listed in 2.1.7, 2.1.10 and 2.1.12	2,0	4,0	—
2.1.7	Maize to be subjected to sorting or other physical treatment before human consumption or use as an ingredient in foodstuffs	5,0	10,0	—
2.1.8	Raw milk ⁽⁶⁾ , heat-treated milk and milk for the manufacture of milk-based products	—	—	0,050

Foodstuffs ⁽¹⁾		Maximum levels (µg/kg)		
2.1.9	Following species of spices: <i>Capsicum</i> spp. (dried fruits thereof, whole or ground, including chillies, chilli powder, cayenne and paprika) <i>Piper</i> spp. (fruits thereof, including white and black pepper) <i>Myristica fragrans</i> (nutmeg) <i>Zingiber officinale</i> (ginger) <i>Curcuma longa</i> (turmeric)	5,0	10,0	—
2.1.10	Processed cereal-based foods and baby foods for infants and young children ⁽³⁾ ⁽⁷⁾	0,10	—	—
2.1.11	Infant formulae and follow-on formulae, including infant milk and follow-on milk ⁽⁴⁾ ⁽⁸⁾	—	—	0,025
2.1.12	Dietary foods for special medical purposes ⁽⁹⁾ ⁽¹⁰⁾ intended specifically for infants	0,10	—	0,025
2.2	Ochratoxin A			
2.2.1	Unprocessed cereals	5,0		
2.2.2	All products derived from unprocessed cereals, including processed cereal products and cereals intended for direct human consumption with the exception of foodstuffs listed in 2.2.9 and 2.2.10	3,0		
2.2.3	Dried vine fruit (currants, raisins and sultanas)	10,0		
2.2.4	Roasted coffee beans and ground roasted coffee, excluding soluble coffee	5,0		
2.2.5	Soluble coffee (instant coffee)	10,0		
2.2.6	Wine (including sparkling wine, excluding liqueur wine and wine with an alcoholic strength of not less than 15 % vol) and fruit wine ⁽¹¹⁾	2,0 ⁽¹²⁾		
2.2.7	Aromatised wine, aromatised wine-based drinks and aromatised wine-product cocktails ⁽¹³⁾	2,0 ⁽¹²⁾		
2.2.8	Grape juice, concentrated grape juice as reconstituted, grape nectar, grape must and concentrated grape must as reconstituted, intended for direct human consumption ⁽¹⁴⁾	2,0 ⁽¹²⁾		
2.2.9	Processed cereal-based foods and baby foods for infants and young children ⁽³⁾ ⁽⁷⁾	0,50		
2.2.10	Dietary foods for special medical purposes ⁽⁹⁾ ⁽¹⁰⁾ intended specifically for infants	0,50		
2.2.11	Green coffee, dried fruit other than dried vine fruit, beer, cocoa and cocoa products, liqueur wines, meat products, spices and liquorice	—		
2.3	Patulin			
2.3.1	Fruit juices, concentrated fruit juices as reconstituted and fruit nectars ⁽¹⁴⁾	50		

	Foodstuffs ⁽¹⁾	Maximum levels (µg/kg)
2.3.2	Spirit drinks ⁽¹⁵⁾ , cider and other fermented drinks derived from apples or containing apple juice	50
2.3.3	Solid apple products, including apple compote, apple puree intended for direct consumption with the exception of foodstuffs listed in 2.3.4 and 2.3.5	25
2.3.4	Apple juice and solid apple products, including apple compote and apple puree, for infants and young children ⁽¹⁶⁾ and labelled and sold as such ⁽⁴⁾	10,0
2.3.5	Baby foods other than processed cereal-based foods for infants and young children ⁽³⁾ ⁽⁴⁾	10,0
2.4	Deoxynivalenol ⁽¹⁷⁾	
2.4.1	Unprocessed cereals ⁽¹⁸⁾ ⁽¹⁹⁾ other than durum wheat, oats and maize	1 250
2.4.2	Unprocessed durum wheat and oats ⁽¹⁸⁾ ⁽¹⁹⁾	1 750
2.4.3	Unprocessed maize ⁽¹⁸⁾	1 750 ⁽²⁰⁾
2.4.4	Cereals intended for direct human consumption, cereal flour (including maize flour, maize meal and maize grits ⁽²¹⁾), bran as end product marketed for direct human consumption and germ, with the exception of foodstuffs listed in 2.4.7	750
2.4.5	Pasta (dry) ⁽²²⁾	750
2.4.6	Bread (including small bakery wares), pastries, biscuits, cereal snacks and breakfast cereals	500
2.4.7	Processed cereal-based foods and baby foods for infants and young children ⁽³⁾ ⁽⁷⁾	200
2.5	Zearalenone ⁽¹⁷⁾	
2.5.1	Unprocessed cereals ⁽¹⁸⁾ ⁽¹⁹⁾ other than maize	100
2.5.2	Unprocessed maize ⁽¹⁸⁾	200 ⁽²⁰⁾
2.5.3	Cereals intended for direct human consumption, cereal flour, bran as end product marketed for direct human consumption and germ, with the exception of foodstuffs listed in 2.5.4, 2.5.7 and 2.5.8	75
2.5.4	Maize intended for direct human consumption, maize flour, maize meal, maize grits, maize germ and refined maize oil ⁽²¹⁾	200 ⁽²⁰⁾
2.5.5	Bread (including small bakery wares), pastries, biscuits, cereal snacks and breakfast cereals, excluding maize snacks and maize based breakfast cereals	50
2.5.6	Maize snacks and maize based breakfast cereals	50 ⁽²⁰⁾

Foodstuffs ⁽¹⁾		Maximum levels (µg/kg)
2.5.7	Processed cereal-based foods (excluding processed maize-based foods) and baby foods for infants and young children ⁽³⁾ ⁽⁷⁾	20
2.5.8	Processed maize-based foods for infants and young children ⁽³⁾ ⁽⁷⁾	20 ⁽²⁰⁾
2.6	Fumonisin	Sum of B ₁ and B ₂
2.6.1	Unprocessed maize ⁽¹⁸⁾	2 000 ⁽²³⁾
2.6.2	Maize flour, maize meal, maize grits, maize germ and refined maize oil ⁽²¹⁾	1 000 ⁽²³⁾
2.6.3	Maize based foods for direct human consumption, excluding foods listed in 2.6.2 and 2.6.4	400 ⁽²³⁾
2.6.4	Processed maize-based foods and baby foods for infants and young children ⁽³⁾ ⁽⁷⁾	200 ⁽²³⁾
2.7	T-2 and HT-2 toxin ⁽¹⁷⁾	Sum of T-2 and HT-2 toxin
2.7.1	Unprocessed cereals ⁽¹⁸⁾ and cereal products	

Section 3: Metals

Foodstuffs ⁽¹⁾		Maximum levels (mg/kg wet weight)
3.1	Lead	
3.1.1	Raw milk ⁽⁶⁾ , heat-treated milk and milk for the manufacture of milk-based products	0,020
3.1.2	Infant formulae and follow-on formulae ⁽⁴⁾ ⁽⁸⁾	0,020
3.1.3	Meat (excluding offal) of bovine animals, sheep, pig and poultry ⁽⁶⁾	0,10
3.1.4	Offal of bovine animals, sheep, pig and poultry ⁽⁶⁾	0,50
3.1.5	Muscle meat of fish ⁽²⁴⁾ ⁽²⁵⁾	0,30
3.1.6	Crustaceans, excluding brown meat of crab and excluding head and thorax meat of lobster and similar large crustaceans (<i>Nephropidae</i> and <i>Palinuridae</i>) ⁽²⁶⁾	0,50
3.1.7	Bivalve molluscs ⁽²⁶⁾	1,5
3.1.8	Cephalopods (without viscera) ⁽²⁶⁾	1,0
3.1.9	Cereals, legumes and pulses	0,20
3.1.10	Vegetables, excluding brassica vegetables, leaf vegetables, fresh herbs and fungi ⁽²⁷⁾ . For potatoes the maximum level applies to peeled potatoes	0,10

	Foodstuffs ⁽¹⁾	Maximum levels (mg/kg wet weight)
3.1.11	Brassica vegetables, leaf vegetables and cultivated fungi ⁽²⁷⁾	0,30
3.1.12	Fruit, excluding berries and small fruit ⁽²⁷⁾	0,10
3.1.13	Berries and small fruit ⁽²⁷⁾	0,20
3.1.14	Fats and oils, including milk fat	0,10
3.1.15	Fruit juices, concentrated fruit juices as reconstituted and fruit nectars ⁽¹⁴⁾	0,050
3.1.16	Wine (including sparkling wine, excluding liqueur wine), cider, perry and fruit wine ⁽¹¹⁾	0,20 ⁽²⁸⁾
3.1.17	Aromatized wine, aromatized wine-based drinks and aromatized wine-product cocktails ⁽¹³⁾	0,20 ⁽²⁸⁾
3.2	Cadmium	
3.2.1	Meat (excluding offal) of bovine animals, sheep, pig and poultry ⁽⁶⁾	0,050
3.2.2	Horsemeat, excluding offal ⁽⁶⁾	0,20
3.2.3	Liver of bovine animals, sheep, pig, poultry and horse ⁽⁶⁾	0,50
3.2.4	Kidney of bovine animals, sheep, pig, poultry and horse ⁽⁶⁾	1,0
3.2.5	Muscle meat of fish ⁽²⁴⁾ ⁽²⁵⁾ , excluding species listed in 3.2.6 and 3.2.7	0,050
3.2.6	Muscle meat of the following fish ⁽²⁴⁾ ⁽²⁵⁾ : anchovy (<i>Engraulis species</i>) bonito (<i>Sarda sarda</i>) common two-banded seabream (<i>Diplodus vulgaris</i>) eel (<i>Anguilla anguilla</i>) grey mullet (<i>Mugil labrosus labrosus</i>) horse mackerel or scad (<i>Trachurus species</i>) louvar or luvar (<i>Luvarus imperialis</i>) sardine (<i>Sardina pilchardus</i>) sardinops (<i>Sardinops species</i>) tuna (<i>Thunnus species</i> , <i>Euthynnus species</i> , <i>Katsuwonus pelamis</i>) wedge sole (<i>Dicologlossa cuneata</i>)	0,10
3.2.7	Muscle meat of swordfish (<i>Xiphias gladius</i>) ⁽²⁴⁾ ⁽²⁵⁾	0,30
3.2.8	Crustaceans, excluding brown meat of crab and excluding head and thorax meat of lobster and similar large crustaceans (<i>Nephropidae</i> and <i>Palinuridae</i>) ⁽²⁶⁾	0,50
3.2.9	Bivalve molluscs ⁽²⁶⁾	1,0
3.2.10	Cephalopods (without viscera) ⁽²⁶⁾	1,0

Foodstuffs ⁽¹⁾		Maximum levels (mg/kg wet weight)
3.2.11	Cereals excluding bran, germ, wheat and rice	0,10
3.2.12	Bran, germ, wheat and rice	0,20
3.2.13	Soybeans	0,20
3.2.14	Vegetables and fruit, excluding leaf vegetables, fresh herbs, fungi, stem vegetables, pine nuts, root vegetables and potatoes ⁽²⁷⁾	0,050
3.2.15	Leaf vegetables, fresh herbs, cultivated fungi and celeriac ⁽²⁷⁾	0,20
3.2.16	Stem vegetables, root vegetables and potatoes, excluding celeriac ⁽²⁷⁾ . For potatoes the maximum level applies to peeled potatoes	0,10
3.3	Mercury	
3.3.1	Fishery products ⁽²⁶⁾ and muscle meat of fish ⁽²⁴⁾ ⁽²⁵⁾ , excluding species listed in 3.3.2. The maximum level applies to crustaceans, excluding the brown meat of crab and excluding head and thorax meat of lobster and similar large crustaceans (<i>Nephropidae</i> and <i>Palinuridae</i>)	0,50
3.3.2	Muscle meat of the following fish ⁽²⁴⁾ ⁽²⁵⁾ : anglerfish (<i>Lophius species</i>) atlantic catfish (<i>Anarhichas lupus</i>) bonito (<i>Sarda sarda</i>) eel (<i>Anguilla species</i>) emperor, orange roughy, rosy soldierfish (<i>Hoplostethus species</i>) grenadier (<i>Coryphaenoides rupestris</i>) halibut (<i>Hippoglossus hippoglossus</i>) marlin (<i>Makaira species</i>) megrin (<i>Lepidorhombus species</i>) mullet (<i>Mullus species</i>) pike (<i>Esox lucius</i>) plain bonito (<i>Orcynopsis unicolor</i>) poor cod (<i>Tricopterus minutes</i>) portuguese dogfish (<i>Centroscyrnus coelolepis</i>) rays (<i>Raja species</i>) redfish (<i>Sebastes marinus</i> , <i>S. mentella</i> , <i>S. viviparus</i>) sail fish (<i>Istiophorus platypterus</i>) scabbard fish (<i>Lepidopus caudatus</i> , <i>Aphanopus carbo</i>) seabream, pandora (<i>Pagellus species</i>) shark (all species) snake mackerel or butterfish (<i>Lepidocybium flavobrunneum</i> , <i>Ruvettus pretiosus</i> , <i>Gempylus serpens</i>) sturgeon (<i>Acipenser species</i>) swordfish (<i>Xiphias gladius</i>) tuna (<i>Thunnus species</i> , <i>Euthynnus species</i> , <i>Katsuwonus pelamis</i>)	1,0
3.4	Tin (inorganic)	
3.4.1	Canned foods other than beverages	200
3.4.2	Canned beverages, including fruit juices and vegetable juices	100

Foodstuffs ⁽¹⁾		Maximum levels (mg/kg wet weight)
3.4.3	Canned baby foods and processed cereal-based foods for infants and young children, excluding dried and powdered products ⁽³⁾ ⁽²⁹⁾	50
3.4.4	Canned infant formulae and follow-on formulae (including infant milk and follow-on milk), excluding dried and powdered products ⁽⁸⁾ ⁽²⁹⁾	50
3.4.5	Canned dietary foods for special medical purposes ⁽⁹⁾ ⁽²⁹⁾ intended specifically for infants, excluding dried and powdered products	50

Section 4: 3-monochloropropane-1,2-diol (3-MCPD)

Foodstuffs ⁽¹⁾		Maximum levels (µg/kg)
4.1	Hydrolysed vegetable protein ⁽³⁰⁾	20
4.2	Soy sauce ⁽³⁰⁾	20

Section 5: Dioxins and PCBs ⁽³¹⁾

Foodstuffs		Maximum levels	
		Sum of dioxins (WHO-PCDD/F-TEQ) ⁽³²⁾	Sum of dioxins and dioxin-like PCBs (WHO-PCDD/F-PCB-TEQ) ⁽³²⁾
5.1	Meat and meat products (excluding edible offal) of the following animals ⁽⁶⁾		
	— bovine animals and sheep	3,0 pg/g fat ⁽³³⁾	4,5 pg/g fat ⁽³³⁾
	— poultry	2,0 pg/g fat ⁽³³⁾	4,0 pg/g fat ⁽³³⁾
	— pigs	1,0 pg/g fat ⁽³³⁾	1,5 pg/g fat ⁽³³⁾
5.2	Liver of terrestrial animals referred to in 5.1 ⁽⁶⁾ , and derived products thereof	6,0 pg/g fat ⁽³³⁾	12,0 pg/g fat ⁽³³⁾
5.3	Muscle meat of fish and fishery products and products thereof, excluding eel ⁽²⁵⁾ ⁽³⁴⁾ . The maximum level applies to crustaceans, excluding the brown meat of crab and excluding head and thorax meat of lobster and similar large crustaceans (<i>Nephropidae</i> and <i>Palinuridae</i>)	4,0 pg/g wet weight	8,0 pg/g wet weight
5.4	Muscle meat of eel (<i>Anguilla anguilla</i>) and products thereof	4,0 pg/g wet weight	12,0 pg/g wet weight
5.5	Raw milk ⁽⁶⁾ and dairy products ⁽⁶⁾ , including butterfat	3,0 pg/g fat ⁽³³⁾	6,0 pg/g fat ⁽³³⁾

	Foodstuffs	Maximum levels	
		Sum of dioxins (WHO-PCDD/F-TEQ) ⁽³²⁾	Sum of dioxins and dioxin-like PCBs (WHO-PCDD/F-PCB-TEQ) ⁽³²⁾
5.6	Hen eggs and egg products ⁽⁶⁾	3,0 pg/g fat ⁽³³⁾	6,0 pg/g fat ⁽³³⁾
5.7	Fat of the following animals: — bovine animals and sheep — poultry — pigs	3,0 pg/g fat 2,0 pg/g fat 1,0 pg/g fat	4,5 pg/g fat 4,0 pg/g fat 1,5 pg/g fat
5.8	Mixed animal fats	2,0 pg/g fat	3,0 pg/g fat
5.9	Vegetable oils and fats	0,75 pg/g fat	1,5 pg/g fat
5.10	Marine oils (fish body oil, fish liver oil and oils of other marine organisms intended for human consumption)	2,0 pg/g fat	10,0 pg/g fat

Section 6: Polycyclic aromatic hydrocarbons

	Foodstuffs	Maximum levels (µg/kg wet weight)
6.1	Benzo(a)pyrene ⁽³⁵⁾	
6.1.1	Oils and fats (excluding cocoa butter) intended for direct human consumption or use as an ingredient in foods	2,0
6.1.2	Smoked meats and smoked meat products	5,0
6.1.3	Muscle meat of smoked fish and smoked fishery products ⁽²⁵⁾ ⁽³⁶⁾ , excluding bivalve molluscs. The maximum level applies to smoked crustaceans, excluding the brown meat of crab and excluding head and thorax meat of lobster and similar large crustaceans (<i>Nephropidae</i> and <i>Palinuridae</i>)	5,0
6.1.4	Muscle meat of fish ⁽²⁴⁾ ⁽²⁵⁾ , other than smoked fish	2,0
6.1.5	Crustaceans, cephalopods, other than smoked ⁽²⁶⁾ . The maximum level applies to crustaceans, excluding the brown meat of crab and excluding head and thorax meat of lobster and similar large crustaceans (<i>Nephropidae</i> and <i>Palinuridae</i>)	5,0
6.1.6	Bivalve molluscs ⁽²⁶⁾	10,0
6.1.7	Processed cereal-based foods and baby foods for infants and young children ⁽³⁾ ⁽²⁹⁾	1,0
6.1.8	Infant formulae and follow-on formulae, including infant milk and follow-on milk ⁽⁸⁾ ⁽²⁹⁾	1,0
6.1.9	Dietary foods for special medical purposes ⁽⁹⁾ ⁽²⁹⁾ intended specifically for infants	1,0

- (¹) As regards fruits, vegetables and cereals, reference is made to the foodstuffs listed in the relevant category as defined in Regulation (EC) No 396/2005 of the European Parliament and of the Council of 23 February 2005 on maximum residue levels of pesticides in or on food and feed of plant and animal origin and amending Council Directive 91/414/EEC (OJ L 70, 16.3.2005, p. 1) as last amended by Regulation (EC) No 178/2006 (OJ L 29, 2.2.2006, p. 3). This means, *inter alia*, that buckwheat (*Fagopyrum* sp) is included in 'cereals' and buckwheat products are included in 'cereal products'.
- (²) The maximum levels do not apply for fresh spinach to be subjected to processing and which is directly transported in bulk from field to processing plant.
- (³) Foodstuffs listed in this category as defined in Commission Directive 96/5/EC of 16 February 1996 on processed cereal-based foods and baby foods for infants and young children (OJ L 49, 28.2.1996, p. 17) as last amended by Directive 2003/13/EC (OJ L 41, 14.2.2003, p. 33).
- (⁴) The maximum level refers to the products ready to use (marketed as such or after reconstitution as instructed by the manufacturer).
- (⁵) The maximum levels refer to the edible part of groundnuts and nuts. If groundnuts and nuts 'in shell' are analysed, it is assumed when calculating the aflatoxin content all the contamination is on the edible part.
- (⁶) Foodstuffs listed in this category as defined in Regulation (EC) No 853/2004 of the European Parliament and of the Council of 29 April 2004 laying down specific hygiene rules for food of animal origin (OJ L 226, 25.6.2004, p. 22).
- (⁷) The maximum level refers to the dry matter. The dry matter is determined in accordance with Regulation (EC) No 401/2006.
- (⁸) Foodstuffs listed in this category as defined in Commission Directive 91/321/EEC of 14 May 1991 on infant formulae and follow-on formulae (OJ L 175, 4.7.1991, p. 35) as last amended by Directive 2003/14/EC (OJ L 41, 14.2.2003, p. 37).
- (⁹) Foodstuffs listed in this category as defined in Commission Directive 1999/21/EC of 25 March 1999 on dietary foods for special medical purposes (OJ L 91, 7.4.1999, p. 29).
- (¹⁰) The maximum level refers in the case of milk and milk products, to the products ready for use (marketed as such or reconstituted as instructed by the manufacturer) and in the case of products other than milk and milk products, to the dry matter. The dry matter is determined in accordance with Regulation (EC) No 401/2006.
- (¹¹) Foodstuffs listed in this category as defined in Council Regulation (EC) No 1493/1999 of 17 May 1999 on the common organisation of the market in wine (OJ L 179, 14.7.1999, p. 1) as last amended by the Protocol concerning the conditions and arrangements for admission of the Republic of Bulgaria and Romania to the European Union (OJ L 157, 21.6.2005, p. 29).
- (¹²) The maximum level applies to products produced from the 2005 harvest onwards.
- (¹³) Foodstuffs listed in this category as defined in Council Regulation (EEC) No 1601/91 of 10 June 1991 laying down general rules on the definition, description and presentation of aromatised wines, aromatised wine-based drinks and aromatised wine-product cocktails (OJ L 149, 14.6.1991, p. 1) as last amended by the Protocol concerning the conditions and arrangements for admission of the Republic of Bulgaria and Romania to the European Union. The maximum level for OTA applicable to these beverages is function of the proportion of wine and/or grape must present in the finished product.
- (¹⁴) Foodstuffs listed in this category as defined in Council Directive 2001/112/EC of 20 December 2001 relating to fruit juices and certain similar products intended for human consumption (OJ L 10, 12.1.2002, p. 58).
- (¹⁵) Foodstuffs listed in this category as defined in Council Regulation (EEC) No 1576/89 of 29 May 1989 laying down general rules on the definition, description and presentation of spirit drinks (OJ L 160, 12.6.1989, p. 1), as last amended by the Protocol concerning the conditions and arrangements for admission of the Republic of Bulgaria and Romania to the European Union.
- (¹⁶) Infants and young children as defined in Directive 91/321/EEC and Directive 96/5/EC.
- (¹⁷) For the purpose of the application of maximum levels for deoxynivalenol, zearalenone, T-2 and HT-2 toxin established in points 2.4, 2.5 and 2.7 rice is not included in 'cereals' and rice products are not included in 'cereal products'.
- (¹⁸) The maximum level applies to unprocessed cereals placed on the market for first-stage processing. 'First-stage processing' shall mean any physical or thermal treatment, other than drying, of or on the grain. Cleaning, sorting and drying procedures are not considered to be 'first-stage processing' insofar no physical action is exerted on the grain kernel itself and the whole grain remains intact after cleaning and sorting. In integrated production and processing systems, the maximum level applies to the unprocessed cereals in case they are intended for first-stage processing.
- (¹⁹) The maximum level applies to cereals harvested and taken over, as from the 2005/06 marketing year, in accordance with Commission Regulation (EC) No 824/2000 of 19 April 2000 establishing procedures for the taking-over of cereals by intervention agencies and laying down methods of analysis for determining the quality of cereals (OJ L 100, 20.4.2000, p. 31), as last amended by Regulation (EC) No 1068/2005 (OJ L 174, 7.7.2005, p. 65).
- (²⁰) Maximum level shall apply from 1 July 2007.
- (²¹) This category includes also similar products otherwise denominated such as semolina.
- (²²) Pasta (dry) means pasta with a water content of approximately 12 %.

- (23) Maximum level shall apply from 1 October 2007.
- (24) Fish listed in this category as defined in category (a), with the exclusion of fish liver falling under code CN 0302 70 00, of the list in Article 1 of Council Regulation (EC) No 104/2000 (OJ L 17, 21.1.2000, p. 22) as last amended by the Act concerning the conditions of accession of the Czech Republic, the Republic of Estonia, the Republic of Cyprus, the Republic of Latvia, the Republic of Lithuania, the Republic of Hungary, the Republic of Malta, the Republic of Poland, the Republic of Slovenia and the Slovak Republic and the adjustments to the Treaties on which the European Union is founded (OJ L 236, 23.9.2003, p. 33). In case of dried, diluted, processed and/or compound foodstuffs Article 2(1) and 2(2) apply.
- (25) Where fish are intended to be eaten whole, the maximum level shall apply to the whole fish.
- (26) Foodstuffs falling within category (c) and (f) of the list in Article 1 of Regulation (EC) No 104/2000, as appropriate (species as listed in the relevant entry). In case of dried, diluted, processed and/or compound foodstuffs Article 2(1) and 2(2) apply.
- (27) The maximum level applies after washing of the fruit or vegetables and separating the edible part.
- (28) The maximum level applies to products produced from the 2001 fruit harvest onwards.
- (29) The maximum level refers to the product as sold.
- (30) The maximum level is given for the liquid product containing 40 % dry matter, corresponding to a maximum level of 50 µg/kg in the dry matter. The level needs to be adjusted proportionally according to the dry matter content of the products.
- (31) Dioxins (sum of polychlorinated dibenzo-para-dioxins (PCDDs) and polychlorinated dibenzofurans (PCDFs), expressed as World Health Organisation (WHO) toxic equivalent using the WHO-toxic equivalency factors (WHO-TEFs)) and sum of dioxins and dioxin-like PCBs (sum of PCDDs, PCDFs and polychlorinated biphenyls (PCBs), expressed as WHO toxic equivalent using the WHO-TEFs). WHO-TEFs for human risk assessment based on the conclusions of the WHO meeting in Stockholm, Sweden, 15 to 18 June 1997 (Van den Berg et al., (1998) Toxic Equivalency Factors (TEFs) for PCBs, PCDDs, PCDFs for Humans and for Wildlife. Environmental Health Perspectives, 106 (12), 775).

Congener	TEF value	Congener	TEF value
Dibenzo-p-dioxins (PCDDs)		Dioxin-like PCBs: Non-ortho PCBs + Mono-ortho PCBs	
2,3,7,8-TCDD	1	<i>Non-ortho PCBs</i>	
1,2,3,7,8-PeCDD	1	PCB 77	0,0001
1,2,3,4,7,8-HxCDD	0,1	PCB 81	0,0001
1,2,3,6,7,8-HxCDD	0,1	PCB 126	0,1
1,2,3,7,8,9-HxCDD	0,1	PCB 169	0,01
1,2,3,4,6,7,8-HpCDD	0,01		
OCDD	0,0001	<i>Mono-ortho PCBs</i>	
Dibenzofurans (PCDFs)		PCB 105	0,0001
2,3,7,8-TCDF	0,1	PCB 114	0,0005
1,2,3,7,8-PeCDF	0,05	PCB 118	0,0001
2,3,4,7,8-PeCDF	0,5	PCB 123	0,0001
1,2,3,4,7,8-HxCDF	0,1	PCB 156	0,0005
1,2,3,6,7,8-HxCDF	0,1	PCB 157	0,0005
1,2,3,7,8,9-HxCDF	0,1	PCB 167	0,00001
2,3,4,6,7,8-HxCDF	0,1	PCB 189	0,0001
1,2,3,4,6,7,8-HpCDF	0,01		
1,2,3,4,7,8,9-HpCDF	0,01		
OCDF	0,0001		

Abbreviations used: 'T' = tetra; 'Pe' = penta; 'Hx' = hexa; 'Hp' = hepta; 'O' = octa; 'CDD' = chlorodibenzodioxin; 'CDF' = chlorodibenzofuran; 'CB' = chlorobiphenyl.

- (32) Upperbound concentrations: Upperbound concentrations are calculated on the assumption that all the values of the different congeners below the limit of quantification are equal to the limit of quantification.
- (33) The maximum level is not applicable for foods containing < 1 % fat.
- (34) Foodstuffs listed in this category as defined in categories (a), (b), (c), (e) and (f) of the list in Article 1 of Regulation (EC) No 104/2000 with the exclusion of fish liver falling under code CN 0302 70 00.
- (35) Benzo(a)pyrene, for which maximum levels are listed, is used as a marker for the occurrence and effect of carcinogenic polycyclic aromatic hydrocarbons. These measures therefore provide full harmonisation on polycyclic aromatic hydrocarbons in the listed foods across the Member States.
- (36) Foodstuffs listed in this category as defined in categories (b), (c), and (f) of the list in Article 1 of Regulation (EC) No 104/2000.

Annex II:

Official Journal of the European Union

**COMMISSION REGULATION (EU) No 835/2011
of 19 August 2011**

**amending Regulation (EC) No 1881/2006 as regards maximum levels for polycyclic aromatic
hydrocarbons in foodstuffs**

COMMISSION REGULATION (EU) No 835/2011

of 19 August 2011

amending Regulation (EC) No 1881/2006 as regards maximum levels for polycyclic aromatic hydrocarbons in foodstuffs

(Text with EEA relevance)

THE EUROPEAN COMMISSION,

Having regard to the Treaty on the Functioning of the European Union,

Having regard to Council Regulation (EEC) No 315/93 of 8 February 1993 laying down Community procedures for contaminants in food ⁽¹⁾, and in particular Article 2(3) thereof,

Whereas:

- (1) Commission Regulation (EC) No 1881/2006 setting maximum levels for certain contaminants in foodstuffs ⁽²⁾ sets maximum levels for benzo(a)pyrene in a range of foodstuffs.
- (2) Benzo(a)pyrene belongs to the group of polycyclic aromatic hydrocarbons (PAH) and is used as a marker for the occurrence and effect of carcinogenic PAH in food based on a scientific opinion of the former Scientific Committee on Food (SCF) ⁽³⁾. In its opinion of December 2002, the SCF recommended that further analyses of the relative proportions of these PAH in foods would be necessary for a future review of the suitability of maintaining benzo(a)pyrene as a marker.
- (3) New data on occurrence of carcinogenic PAH in foodstuffs have been collected by the Member States in the framework of Commission Recommendation 2005/108/EC ⁽⁴⁾. The Commission asked the European Food Safety Authority (EFSA) to review the SCF opinion taking into account the new occurrence data, other relevant new scientific information as well as the Margin of Exposure (MOE) approach. Within this review, EFSA was asked to re-assess the suitability of maintaining benzo(a)pyrene as a marker.
- (4) The Scientific Panel on Contaminants in the Food Chain (CONTAM Panel) of EFSA adopted an opinion on Poly-

cyclic Aromatic Hydrocarbons in Food on 9 June 2008 ⁽⁵⁾. In this opinion EFSA concluded that benzo(a)pyrene is not a suitable marker for the occurrence of polycyclic aromatic hydrocarbons in food and that a system of four specific substances (PAH4 ⁽⁶⁾) or eight specific substances (PAH8 ⁽⁷⁾) would be the most suitable indicators of PAH in food. EFSA also concluded that a system of eight substances (PAH8) would not provide much added value compared to a system of four substances (PAH4).

- (5) Furthermore, the CONTAM Panel concluded, using the Margin of Exposure (MOE) approach, that there is low concern for consumer health at the average estimated dietary exposures. However, for high level consumers the MOEs were close to or less than 10 000, which indicates a potential concern for consumer health.
- (6) Based on the conclusions of EFSA, the current system of using benzo(a)pyrene as the only marker for the group of polycyclic aromatic hydrocarbons, can not be maintained. An amendment of Regulation (EC) No 1881/2006 is therefore necessary.
- (7) New maximum levels for the sum of four substances (PAH4) (benzo(a)pyrene, benz(a)anthracene, benzo(b)fluoranthene and chrysene) should be introduced, whilst maintaining a separate maximum level for benzo(a)pyrene.
- (8) Such system would ensure that PAH levels in food are kept at levels that do not cause health concern and that the amount of PAH can also be controlled in those samples in which benzo(a)pyrene is not detectable, but where other PAH are present.
- (9) The separate maximum level for benzo(a)pyrene is maintained to ensure comparability of previous and future data. After a certain time of implementation of this amendment and on basis of new data that will be generated in future, the need for retaining a separate maximum level for benzo(a) pyrene should be re-assessed.

⁽¹⁾ OJ L 37, 13.2.1993, p. 1.

⁽²⁾ OJ L 364, 20.12.2006, p. 5.

⁽³⁾ Opinion of the Scientific Committee on Food on the risks to human health of Polycyclic Aromatic Hydrocarbons in food (expressed on 4 December 2002).

http://ec.europa.eu/food/fs/sc/scf/out153_en.pdf

⁽⁴⁾ OJ L 34, 8.2.2005, p. 43.

⁽⁵⁾ *The EFSA Journal* (2008) 724, 1-114.

⁽⁶⁾ Benzo(a)pyrene, Chrysene, Benz(a)anthracene, benzo(b)fluoranthene.

⁽⁷⁾ Benzo(a)pyrene, Chrysene, Benz(a)anthracene, benzo(b)fluoranthene, benzo(k)fluoranthene, benzo(g,h,i)perylene, dibenz(a,h)anthracene and indeno(1,2,3-c,d)pyrene.

- (10) As regards the sum of the four substances (PAH4), lower bound concentrations should be used as the basis for compliance decisions.
- (11) Maximum levels for polycyclic aromatic hydrocarbons must be safe and as low as reasonably achievable (ALARA) based upon good manufacturing and agricultural/fishery practices. The new PAH occurrence data show that background levels of PAH are lower than previously thought in some food commodities. Benzo(a)pyrene maximum levels have therefore been adapted to reflect more realistic lower background levels in fresh and smoked bivalve molluscs.
- (12) Data for smoked fish and smoked meat have also shown that lower maximum levels are achievable. Nevertheless, adaptations of current smoking technology may be necessary in some cases. Therefore, a two step procedure should be established for smoked meat and smoked fish which grants a transition of two years from the date of application of this Regulation before lower maximum levels become applicable.
- (13) Smoked sprats and canned smoked sprats have been found to contain higher levels of PAH than other smoked fish. Specific maximum levels should be established for smoked sprats and canned smoked sprats in order to reflect what is achievable in these foodstuffs.
- (14) Previously a maximum level for benzo(a)pyrene in "muscle meat of fish other than smoked fish" was established as an indicator for potential environmental pollution. Nevertheless, it has been shown that PAH are quickly metabolised in fresh fish and do not accumulate in the muscle meat. Therefore, maintaining a maximum level for PAH in fresh fish is no longer appropriate.
- (15) High levels of PAH have been found in some types of heat treated meat and heat treated meat products sold to the final consumer. These levels are avoidable if appropriate processing conditions and equipment are used. It is therefore appropriate to establish maximum levels for PAH in meat and meat products that have undergone a heat treatment process known to potentially result in formation of PAH, i.e. only grilling and barbecuing.
- (16) Cocoa butter was temporarily exempted from the existing maximum level for benzo(a)pyrene in oils and fats under Regulation (EC) No 1881/2006 and a review of the appropriateness of setting a maximum level for PAH in cocoa butter was foreseen by 1 April 2007. The review was then postponed pending the result of the then ongoing scientific re-assessment of PAH by EFSA.
- (17) Cocoa butter contains higher levels of PAH than other oils and fats. This is mainly due to inappropriate drying practices of the cocoa beans and the fact that cocoa butter can not be refined as other vegetable oils and fats. Cocoa butter is a main constituent of cocoa raw products (e.g. cocoa beans, cocoa mass, cocoa nibs or cocoa liquor) and is present in chocolate and other cocoa products often consumed by children. It thereby contributes to human exposure, in particular to exposure of children. It is therefore necessary to establish maximum levels for PAH in cocoa beans and derived products, thereby also including cocoa butter.
- (18) Maximum levels for PAH in cocoa beans should be established at levels as low as reasonably achievable and taking into account the current technological possibilities of producing countries. They should be established on a fat basis since PAH concentrate in the fat fraction, the cocoa butter. To allow producing countries to make technological improvements in order to adapt to these maximum levels, the date of application of the maximum levels for cocoa beans and derived products should be deferred. Furthermore, initially a higher maximum level for the sum of the four substances should apply to these products. After a transition period of two years a lower maximum level should apply. The levels of PAH in cocoa beans and derived products should be regularly monitored with a view to assessing the possibility for further decreasing the maximum levels in future.
- (19) Data have shown that coconut oil can contain higher amounts of PAH4 than other vegetable oils and fats. This is due to the proportionally higher presence of benz(a)anthracene and chrysene which can not be easily removed during refinement of coconut oil. Specific maximum levels for coconut oil should therefore be set at levels as low as reasonably achievable and taking into account the current technological possibilities of producing countries. As technological improvements in producing countries are expected, the levels of PAH in coconut oil should be regularly monitored with a view to assessing the possibility for setting lower levels in future.
- (20) Current occurrence data on PAH in cereals and vegetables are limited. The available data indicate that cereals and vegetables contain rather low levels of PAH. The low levels seen in the currently available occurrence data do not justify the immediate setting of maximum levels. Nevertheless, EFSA identified cereals and vegetables as being important contributors to human exposure due to their high consumption. Therefore, PAH levels in these two product groups should be further monitored. On the basis of further data, the need for setting maximum levels will be evaluated.

- (21) High levels of PAH have been found in some food supplements. Nevertheless, the levels are variable and depend on the specific type of food supplements. Further data on food supplements are needed and should be collected. Once these data become available, the need for setting maximum levels for PAH in food supplements will be evaluated.
- (22) Member States and food business operators should be allowed time to adapt to the maximum levels established by this Regulation. The date of application of this Regulation should therefore be deferred. A transitional period should be provided for the products already placed on the market before the date of application of the amendments introduced by this Regulation.
- (23) The measures provided for in this Regulation are in accordance with the opinion of the Standing Committee on the Food Chain and Animal Health and neither the European Parliament nor the Council have opposed them,

HAS ADOPTED THIS REGULATION:

Article 1

The Annex to Regulation (EC) No 1881/2006 is amended in accordance with the Annex to this Regulation.

Article 2

1. Foodstuffs not complying with the maximum levels applicable from 1 September 2012 pursuant to Section 6 "Polycyclic aromatic hydrocarbons" of the Annex to Regulation (EC) No 1881/2006, as amended by this Regulation, which are

lawfully placed on the market prior to 1 September 2012, may continue to be marketed after that date until their date of minimum durability or use-by-date.

2. Foodstuffs not complying with the maximum levels applicable from 1 September 2014 pursuant to points 6.1.4 and 6.1.5 of the Annex to Regulation (EC) No 1881/2006, as amended by this Regulation, which are lawfully placed on the market prior to 1 September 2014, may continue to be marketed after that date until their date of minimum durability or use-by-date.

3. Foodstuffs not complying with the maximum levels applicable from 1 April 2013 pursuant to point 6.1.2 of the Annex to Regulation (EC) No 1881/2006, as amended by this Regulation, which are lawfully placed on the market prior to 1 April 2013, may continue to be marketed after that date until their date of minimum durability or use-by-date.

4. Foodstuffs not complying with the maximum level applicable from 1 April 2015 pursuant to point 6.1.2 of the Annex to Regulation (EC) No 1881/2006, as amended by this Regulation, which are lawfully placed on the market prior to 1 April 2015, may continue to be marketed after that date until their date of minimum durability or use-by-date.

Article 3

This Regulation shall enter into force on the twentieth day following that of its publication in the *Official Journal of the European Union*.

It shall apply from 1 September 2012.

This Regulation shall be binding in its entirety and directly applicable in all Member States.

Done at Brussels, 19 August 2011.

For the Commission

The President

José Manuel BARROSO

ANNEX

The Annex to Regulation (EC) No 1881/2006 is amended as follows:

(1) Section 6: *Polycyclic aromatic hydrocarbons* is replaced by the following:

"Section 6: *Polycyclic aromatic hydrocarbons*

Foodstuffs		Maximum levels (µg/kg)	
6.1	Benzo(a)pyrene, benz(a)anthracene, benzo(b)fluoranthene and chrysene	Benzo(a)pyrene	Sum of benzo(a)pyrene, benz(a)anthracene, benzo(b)fluoranthene and chrysene ⁽⁴⁵⁾
6.1.1	Oils and fats (excluding cocoa butter and coconut oil) intended for direct human consumption or use as an ingredient in food	2,0	10,0
6.1.2	Cocoa beans and derived products	5,0 µg/kg fat as from 1.4.2013	35,0 µg/kg fat as from 1.4.2013 until 31.3.2015 30,0 µg/kg fat as from 1.4.2015
6.1.3	Coconut oil intended for direct human consumption or use as an ingredient in food	2,0	20,0
6.1.4	Smoked meat and smoked meat products	5,0 until 31.8.2014 2,0 as from 1.9.2014	30,0 as from 1.9.2012 until 31.8.2014 12,0 as from 1.9.2014
6.1.5	Muscle meat of smoked fish and smoked fishery products ⁽²⁵⁾⁽³⁶⁾ , excluding fishery products listed in points 6.1.6 and 6.1.7. The maximum level for smoked crustaceans applies to muscle meat from appendages and abdomen ⁽⁴⁴⁾ . In case of smoked crabs and crab-like crustaceans (<i>Brachyura</i> and <i>Anomura</i>) it applies to muscle meat from appendages.	5,0 until 31.8.2014 2,0 as from 1.9.2014	30,0 as from 1.9.2012 until 31.8.2014 12,0 as from 1.9.2014
6.1.6	Smoked sprats and canned smoked sprats ⁽²⁵⁾⁽⁴⁷⁾ (<i>sprattus sprattus</i>); bivalve molluscs (fresh, chilled or frozen) ⁽²⁶⁾ ; heat treated meat and heat treated meat products ⁽⁴⁶⁾ sold to the final consumer	5,0	30,0
6.1.7	Bivalve molluscs ⁽³⁶⁾ (smoked)	6,0	35,0
6.1.8	Processed cereal-based foods and baby foods for infants and young children ⁽³⁾⁽²⁹⁾	1,0	1,0
6.1.9	Infant formulae and follow-on formulae, including infant milk and follow-on milk ⁽⁸⁾⁽²⁹⁾	1,0	1,0

Foodstuffs		Maximum levels ($\mu\text{g}/\text{kg}$)	
6.1.10	Dietary foods for special medical purposes (⁹)(²⁹) intended specifically for infants	1,0	1,0

(⁴⁵) Lower bound concentrations are calculated on the assumption that all the values of the four substances below the limit of quantification are zero.

(⁴⁶) Meat and meat products that have undergone a heat treatment potentially resulting in formation of PAH, i.e. only grilling and barbecuing.

(⁴⁷) For the canned product the analysis shall be carried out on the whole content of the can. As regards the maximum level for the whole composite product Art. 2(1)(c) and 2(2) shall apply."

(2) Endnote (³⁵) is deleted.

Annex III:

Official Journal of the European Union

**COMMISSION REGULATION (EU) No 836/2011
of 19 August 2011**

**amending Regulation (EC) No 333/2007 laying down the methods of sampling and analysis for
the official control of the levels of lead, cadmium, mercury, inorganic tin, 3-MCPD and
benzo(a)pyrene in foodstuffs**

COMMISSION REGULATION (EU) No 836/2011

of 19 August 2011

amending Regulation (EC) No 333/2007 laying down the methods of sampling and analysis for the official control of the levels of lead, cadmium, mercury, inorganic tin, 3-MCPD and benzo(a)pyrene in foodstuffs

(Text with EEA relevance)

THE EUROPEAN COMMISSION,

Having regard to the Treaty on the Functioning of the European Union,

Having regard to Regulation (EC) No 882/2004 of the European Parliament and of the Council of 29 April 2004 on official controls performed to ensure the verification of compliance with feed and food law, animal health and animal welfare rules ⁽¹⁾, in particular Article 11(4) thereof,

Whereas:

- (1) Commission Regulation (EC) No 1881/2006 of 19 December 2006 setting maximum levels for certain contaminants in foodstuffs ⁽²⁾ established, inter alia, maximum levels for the contaminant benzo(a)pyrene.
- (2) The Scientific Panel on Contaminants in the Food Chain of the European Food Safety Authority (EFSA) adopted an opinion on Polycyclic Aromatic Hydrocarbons in Food on 9 June 2008 ⁽³⁾. The EFSA concluded that benzo(a)pyrene is not a suitable marker for the occurrence of polycyclic aromatic hydrocarbons (PAH) in food and that a system of four specific substances or eight specific substances would be the most suitable markers of PAH in food. The EFSA also concluded that a system of eight substances would not provide much added value compared to a system of four substances.
- (3) As a consequence Commission Regulation (EU) No 835/2011 ⁽⁴⁾ amended Regulation (EC) No 1881/2006 in order to set maximum levels for the sum of four polycyclic aromatic hydrocarbons (benzo(a)pyrene, benz(a)anthracene, benzo(b)fluoranthene and chrysene).
- (4) Commission Regulation (EC) No 333/2007 ⁽⁵⁾ lays down analytical performance criteria only for benzo(a)pyrene. It is therefore necessary to lay down analytical performance criteria for the other three substances for which maximum levels are now set out in Regulation (EC) No 1881/2006.

- (5) The European Union Reference Laboratory for Polycyclic Aromatic Hydrocarbons (EU-RL PAH) in collaboration with the national reference laboratories carried out a survey among official control laboratories to assess which analytical performance criteria would be achievable for benzo(a)pyrene, benz(a)anthracene, benzo(b)fluoranthene and chrysene in relevant food matrices. The outcome of this survey was summarised by the EU-RL PAH in the Report on 'Performance characteristics of analysis methods for the determination of 4 polycyclic aromatic hydrocarbons in food' ⁽⁶⁾. The results of the survey show that the analytical performance criteria currently applicable to benzo(a)pyrene are also suitable for the other three substances.

- (6) Experience acquired while implementing Regulation (EC) No 333/2007 revealed that in some cases the current sampling provisions may be impracticable or may lead to unacceptable economic damage to the sampled lot. For such cases, departure from the sampling procedures should be allowed, provided that sampling remains sufficiently representative of the sampled lot or subplot and that the procedure used is fully documented. For sampling at the retail stage, flexibility to depart from the sampling procedures existed already. The provisions for sampling at retail stage should be aligned with the general sampling procedures.
- (7) More detailed provisions are needed as regards the material of sampling containers when samples are taken for PAH analysis. Plastic containers are widely used by enforcement authorities, but they are not suitable when sampling is carried out for PAH analysis, as the PAH content of the sample can be altered by these materials.
- (8) Clarification is needed for some aspects of the specific requirements for analytical methods, in particular the requirements regarding the use of the performance criteria and the 'fitness-for-purpose' approach. Furthermore, the presentation of the tables with the performance criteria should be modified to appear more uniform across all analytes.
- (9) Regulation (EC) No 333/2007 should therefore be amended accordingly. Since Regulation (EU) No 835/2011 and this Regulation are inter-linked, both Regulations should become applicable on the same date.

⁽¹⁾ OJ L 165, 30.4.2004, p. 1.

⁽²⁾ OJ L 364, 20.12.2006, p. 5.

⁽³⁾ The EFSA Journal (2008) 724, p. 1.

⁽⁴⁾ See page 4 of this Official Journal.

⁽⁵⁾ OJ L 88, 29.3.2007, p. 29.

⁽⁶⁾ JRC Report 59046, 2010.

(10) The measures provided for in this Regulation are in accordance with the opinion of the Standing Committee on the Food Chain and Animal Health and neither the European Parliament nor the Council have opposed them,

HAS ADOPTED THIS REGULATION:

Article 1

Regulation (EC) No 333/2007 is amended as follows:

(1) the title is replaced by the following:

'Commission Regulation (EC) No 333/2007 of 28 March 2007 laying down the methods of sampling and analysis for the official control of the levels of lead, cadmium, mercury, inorganic tin, 3-MCPD and polycyclic aromatic hydrocarbons in foodstuffs';

(2) in Article 1, paragraph 1 is replaced by the following:

'1. Sampling and analysis for the official control of the levels of lead, cadmium, mercury, inorganic tin, 3-MCPD and polycyclic aromatic hydrocarbons ("PAH") listed in Sections 3, 4 and 6 of the Annex to Regulation (EC) No 1881/2006 shall be carried out in accordance with the Annex to this Regulation.';

(3) the Annex is amended in accordance with the Annex to this Regulation.

Article 2

This Regulation shall enter into force on the 20th day following its publication in the *Official Journal of the European Union*.

It shall apply from 1 September 2012.

This Regulation shall be binding in its entirety and directly applicable in all Member States.

Done at Brussels, 19 August 2011.

For the Commission

The President

José Manuel BARROSO

ANNEX

The Annex to Regulation (EC) No 333/2007 is amended as follows:

- (1) in point B.1.7 'Packaging and transmission of samples', the following second paragraph is added:

'In case of sampling for PAH analysis plastic containers shall be avoided if possible as they could alter the PAH content of the sample. Inert, PAH-free glass containers, adequately protecting the sample from light, shall be used wherever possible. Where this is practically impossible, at least direct contact of the sample with plastics shall be avoided, e.g. in case of solid samples by wrapping the sample in aluminium foil before placing it in the sampling container.';

- (2) points B.2 and B.3 are replaced by the following:

B.2. SAMPLING PLANS

B.2.1. Division of lots into sublots

Large lots shall be divided into sublots on condition that the subplot may be separated physically. For products traded in bulk consignments (e.g. cereals) Table 1 shall apply. For other products Table 2 shall apply. Taking into account that the weight of the lot is not always an exact multiple of the weight of the sublots, the weight of the subplot may exceed the mentioned weight by a maximum of 20 %.

B.2.2. Number of incremental samples

The aggregate sample shall be at least 1 kg or 1 litre except where it is not possible, e.g. when the sample consists of 1 package or unit.

The minimum number of incremental samples to be taken from the lot or subplot shall be as given in Table 3.

In the case of bulk liquid products the lot or subplot shall be thoroughly mixed in so far as possible and in so far it does not affect the quality of the product, by either manual or mechanical means immediately prior to sampling. In this case, a homogeneous distribution of contaminants is assumed within a given lot or subplot. It is therefore sufficient to take three incremental samples from a lot or subplot to form the aggregate sample.

The incremental samples shall be of similar weight/volume. The weight/volume of an incremental sample shall be at least 100 grams or 100 millilitres, resulting in an aggregate sample of at least about 1 kg or 1 litre. Departure from this method shall be recorded in the record provided for under point B.1.8 of this Annex.

Table 1

Subdivision of lots into sublots for products traded in bulk consignments

Lot weight (ton)	Weight or number of sublots
≥ 1 500	500 tonnes
> 300 and < 1 500	3 sublots
≥ 100 and ≤ 300	100 tonnes
< 100	—

Table 2

Subdivision of lots into sublots for other products

Lot weight (ton)	Weight or number of sublots
≥ 15	15-30 tonnes
< 15	—

Table 3

Minimum number of incremental samples to be taken from the lot or subplot

Weight or volume of lot/sublot (in kg or litre)	Minimum number of incremental samples to be taken
< 50	3
≥ 50 and ≤ 500	5
> 500	10

If the lot or subplot consists of individual packages or units, then the number of packages or units which shall be taken to form the aggregate sample is given in Table 4.

Table 4

Number of packages or units (incremental samples) which shall be taken to form the aggregate sample if the lot or subplot consists of individual packages or units

Number of packages or units in the lot/sublot	Number of packages or units to be taken
≤ 25	at least 1 package or unit
26-100	about 5 %, at least 2 packages or units
> 100	about 5 %, at maximum 10 packages or units

The maximum levels for inorganic tin apply to the contents of each can, but for practical reasons it is necessary to use an aggregate sampling approach. If the result of the test for an aggregate sample of cans is less than but close to the maximum level of inorganic tin and if it is suspected that individual cans might exceed the maximum level, then it might be necessary to conduct further investigations.

Where it is not possible to carry out the method of sampling set out in this chapter because of the unacceptable commercial consequences (e.g. because of packaging forms, damage to the lot, etc.) or where it is practically impossible to apply the abovementioned method of sampling, an alternative method of sampling may be applied provided that it is sufficiently representative for the sampled lot or subplot and is fully documented.

B.2.3. Specific provisions for the sampling of large fish arriving in large lots

In case the lot or subplot to be sampled contains large fishes (individual fishes weighing more than about 1 kg) and the lot or subplot weighs more than 500 kg, the incremental sample shall consist of the middle part of the fish. Each incremental sample shall weigh at least 100 g.

B.3. SAMPLING AT RETAIL STAGE

Sampling of foodstuffs at retail stage shall be done where possible in accordance with the sampling provisions set out in point B.2.2 of this Annex.

Where it is not possible to carry out the method of sampling set out in point B.2.2 because of the unacceptable commercial consequences (e.g. because of packaging forms, damage to the lot, etc.) or where it is practically impossible to apply the abovementioned method of sampling, an alternative method of sampling may be applied provided that it is sufficiently representative for the sampled lot or subplot and is fully documented.;

- (3) in the first paragraph of point C.1 'Laboratory Quality Standards', footnote 1 is deleted;
- (4) in point C.2.2.1 'Specific procedures for lead, cadmium, mercury and inorganic tin', the second paragraph is replaced by the following:

There are many satisfactory specific sample preparation procedures which may be used for the products under consideration. For those aspects not specifically covered by this Regulation, the CEN Standard "Foodstuffs - Determination of trace elements – Performance criteria, general considerations and sample preparation"⁽¹⁾ has been found to be satisfactory but other sample preparation methods may be equally valid.;

- (5) point C.2.2.2 is replaced by the following:

'C.2.2.2. Specific procedures for polycyclic aromatic hydrocarbons

The analyst shall ensure that samples do not become contaminated during sample preparation. Containers shall be rinsed with high purity acetone or hexane before use to minimise the risk of contamination. Wherever possible, apparatus and equipment coming into contact with the sample shall be made of inert materials such as aluminium, glass or polished stainless steel. Plastics such as polypropylene or PTFE shall be avoided because the analytes can adsorb onto these materials.;

(6) point C.3.1 'Definitions' is amended as follows:

(a) the definition for 'HORRAT_r' is replaced by the following:

'HORRAT (*)_r = The observed RSD_r divided by the RSD_r value estimated from the (modified) Horwitz equation (**) (cf. point C.3.3.1 ("Notes to the performance criteria")) using the assumption $r = 0,66 R$.

(*) Horwitz W. and Albert, R., 2006, The Horwitz Ratio (HorRat): A useful Index of Method Performance with respect to Precision, Journal of AOAC International, Vol. 89, 1095-1109.

(**) M. Thompson, Analyst, 2000, p. 125 and 385-386.'

(b) the definition for 'HORRAT_R' is replaced by the following:

'HORRAT (*)_R = The observed RSD_R divided by the RSD_R value estimated from the (modified) Horwitz equation (**) (cf. point C.3.3.1 ("Notes to the performance criteria")).

(*) Horwitz W. and Albert, R., 2006, The Horwitz Ratio (HorRat): A useful Index of Method Performance with respect to Precision, Journal of AOAC International, Vol. 89, 1095-1109.

(**) M. Thompson, Analyst, 2000, p. 125 and 385-386.'

(c) the definition for 'u' is replaced by the following:

'u = Combined standard measurement uncertainty obtained using the individual standard measurement uncertainties associated with the input quantities in a measurement model (*)

(*) International vocabulary of metrology – Basic and general concepts and associated terms (VIM), JCGM 200:2008.;

(7) point C.3.2 is replaced by the following:

'C.3.2 General requirements

Methods of analysis used for food control purposes shall comply with the provisions of Annex III to Regulation (EC) No 882/2004.

Methods for analysis for total tin are appropriate for official control on inorganic tin levels.

For the analysis of lead in wine, the methods and rules established by the OIV (*) apply in accordance with Article 31 of Council Regulation (EC) No 479/2008 (**).

(*) Organisation internationale de la vigne et du vin.

(**) Council Regulation (EC) No 479/2008 of 29 April 2008 on the common organisation of the market in wine amending Regulations (EC) No 1493/1999, (EC) No 1782/2003, (EC) No 1290/2005, (EC) No 3/2008 and repealing Regulations (EEC) No 2392/86 and (EC) No 1493/1999 (OJ L 148, 6.6.2008, p. 1).;

(8) point C.3.3.1 is replaced by the following:

'C.3.3.1. Performance criteria

Where no specific methods for the determination of contaminants in foodstuffs are prescribed at European Union level, laboratories may select any validated method of analysis for the respective matrix provided that the selected method meets the specific performance criteria set out in Tables 5, 6 and 7.

It is recommended that fully validated methods (i.e. methods validated by collaborative trial for the respective matrix) are used where appropriate and available. Other suitable validated methods (e.g. in-house validated methods for the respective matrix) may also be used provided that they fulfil the performance criteria set out in Tables 5, 6 and 7.

Where possible, the validation of in-house validated methods shall include a certified reference material.

- (a) Performance criteria for methods of analysis for lead, cadmium, mercury and inorganic tin:

Table 5

Parameter	Criterion		
Applicability	Foods specified in Regulation (EC) No 1881/2006		
Specificity	Free from matrix or spectral interferences		
Repeatability (RSD _r)	HORRAT _r less than 2		
Reproducibility (RSD _R)	HORRAT _R less than 2		
Recovery	The provisions of point D.1.2 apply		
	Inorganic tin	Lead, cadmium, mercury	
		ML is < 0,100 mg/kg	ML is ≥ 0,100 mg/kg
LOD	≤ 5 mg/kg	≤ one fifth of the ML	≤ one tenth of the ML
LOQ	≤ 10 mg/kg	≤ two fifths of the ML	≤ one fifth of the ML

- (b) Performance criteria for methods of analysis for 3-MCPD:

Table 6

Parameter	Criterion
Applicability	Foods specified in Regulation (EC) No 1881/2006
Specificity	Free from matrix or spectral interferences
Field blanks	Less than LOD
Repeatability (RSD _r)	0,66 times RSD _R as derived from (modified) Horwitz equation
Reproducibility (RSD _R)	as derived from (modified) Horwitz equation
Recovery	75-110 %
LOD	≤ 5 µg/kg (on dry matter basis)
LOQ	≤ 10 µg/kg (on dry matter basis)

- (c) Performance criteria for methods of analysis for polycyclic aromatic hydrocarbons:

The four polycyclic aromatic hydrocarbons to which these criteria apply are benzo(a)pyrene, benz(a)anthracene, benzo(b)fluoranthene and chrysene.

Table 7

Parameter	Criterion
Applicability	Foods specified in Regulation (EC) No 1881/2006
Specificity	Free from matrix or spectral interferences, verification of positive detection
Repeatability (RSD _r)	HORRAT _r less than 2
Reproducibility (RSD _R)	HORRAT _R less than 2

Parameter	Criterion
Recovery	50-120 %
LOD	≤ 0,30 µg/kg for each of the four substances
LOQ	≤ 0,90 µg/kg for each of the four substances

(d) Notes to the performance criteria:

The Horwitz equation (*) (for concentrations $1,2 \times 10^{-7} \leq C \leq 0,138$) and the modified Horwitz equation (**) (for concentrations $C < 1,2 \times 10^{-7}$) are generalised precision equations which are independent of analyte and matrix but solely dependent on concentration for most routine methods of analysis.

Modified Horwitz equation for concentrations $C < 1,2 \times 10^{-7}$:

$$RSD_R = 22 \%$$

where:

- RSD_R is the relative standard deviation calculated from results generated under reproducibility conditions $[(s_R / \bar{x}) \times 100]$
- C is the concentration ratio (i.e. 1 = 100 g/100 g, 0,001 = 1 000 mg/kg). The modified Horwitz equation applies to concentrations $C < 1,2 \times 10^{-7}$.

Horwitz equation for concentrations $1,2 \times 10^{-7} \leq C \leq 0,138$:

$$RSD_R = 2C^{(-0,15)}$$

where:

- RSD_R is the relative standard deviation calculated from results generated under reproducibility conditions $[(s_R / \bar{x}) \times 100]$
- C is the concentration ratio (i.e. 1 = 100 g/100 g, 0,001 = 1 000 mg/kg). The Horwitz equation applies to concentrations $1,2 \times 10^{-7} \leq C \leq 0,138$.

(*) W. Horwitz, L.R. Kamps, K.W. Boyer, J.Assoc.Off.Analy.Chem.,1980, 63, 1344.

(**) M. Thompson, Analyst, 2000, p. 125 and 385-386.;

(9) point C.3.3.2 is replaced by the following:

'C.3.3.2. "Fitness-for-purpose" approach

For in-house validated methods, as an alternative a "fitness-for-purpose" approach (*) may be used to assess their suitability for official control. Methods suitable for official control must produce results with a combined standard measurement uncertainty (u) less than the maximum standard measurement uncertainty calculated using the formula below:

$$U_f = \sqrt{(LOD/2)^2 + (\alpha C)^2}$$

where:

- U_f is the maximum standard measurement uncertainty (µg/kg).
- LOD is the limit of detection of the method (µg/kg). The LOD must meet the performance criteria set in point C.3.3.1 for the concentration of interest.
- C is the concentration of interest (µg/kg);
- α is a numeric factor to be used depending on the value of C . The values to be used are given in Table 8.

Table 8

Numeric values to be used for α as constant in formula set out in this point, depending on the concentration of interest

C (µg/kg)	α
≤ 50	0,2
51-500	0,18

C (µg/kg)	α
501-1 000	0,15
1 001-10 000	0,12
> 10 000	0,1

The analyst shall note the "Report on the relationship between analytical results, measurement uncertainty, recovery factors and the provisions of EU food and feed legislation" (**).

(*) M. Thompson and R. Wood, *Accred. Qual. Assur.*, 2006, p. 10 and 471-478.

(**) http://ec.europa.eu/food/food/chemicalsafety/contaminants/report-sampling_analysis_2004_en.pdf;

(10) in point D.1.2 'Recovery calculations', the second paragraph is replaced by the following:

'In case no extraction step is applied in the analytical method (e.g. in case of metals), the result may be reported uncorrected for recovery if evidence is provided by ideally making use of suitable certified reference material that the certified concentration allowing for the measurement uncertainty is achieved (i.e. high accuracy of the measurement), and thus that the method is not biased. In case the result is reported uncorrected for recovery this shall be mentioned.';

(11) in point D.1.3 'Measurement uncertainty', the second paragraph is replaced by the following:

'The analyst shall note the "Report on the relationship between analytical results, measurement uncertainty, recovery factors and the provisions of EU food and feed legislation" (*).

(*) http://ec.europa.eu/food/food/chemicalsafety/contaminants/report-sampling_analysis_2004_en.pdf.

Annex IV:

Official Journal of the European Union

COMMISSION REGULATION (EU) No 2017/644

of 5 April 2017

laying down methods of sampling and analysis for the control of levels of dioxins, dioxin-like PCBs and non-dioxin-like PCBs in certain foodstuffs and repealing Regulation (EU)

No 589/2014

COMMISSION REGULATION (EU) 2017/644

of 5 April 2017

laying down methods of sampling and analysis for the control of levels of dioxins, dioxin-like PCBs and non-dioxin-like PCBs in certain foodstuffs and repealing Regulation (EU) No 589/2014

(Text with EEA relevance)

THE EUROPEAN COMMISSION,

Having regard to the Treaty on the Functioning of the European Union,

Having regard to Regulation (EC) No 882/2004 of the European Parliament and of the Council of 29 April 2004 on official controls performed to ensure the verification of compliance with feed and food law, animal health and animal welfare rules ⁽¹⁾, and in particular Article 11(4) thereof,

Whereas:

- (1) Commission Regulation (EC) No 1881/2006 ⁽²⁾ sets out the maximum levels for non-dioxin-like polychlorinated biphenyls (PCBs) dioxins and furans and for the sum of dioxins, furans and dioxin-like PCBs in certain foodstuffs.
- (2) Commission Recommendation 2013/711/EU ⁽³⁾ sets out action levels in order to stimulate a proactive approach to reduce the presence of polychlorinated dibenzo-para-dioxins and polychlorinated dibenzofurans (PCDD/Fs) and dioxin-like PCBs in food. Those action levels are a tool used by competent authorities and operators to highlight those cases where it is appropriate to identify a source of contamination and to take the necessary measures in order to reduce or eliminate it.
- (3) Commission Regulation (EC) No 589/2014 ⁽⁴⁾ establishes specific provisions concerning the sampling procedure and the methods of analysis to be applied for the official control of levels of dioxins, dioxin-like PCBs and non-dioxin-like PCBs.
- (4) The provisions laid down in this Regulation relate only to the sampling and analysis of dioxins, dioxin-like PCBs and non-dioxin-like PCBs for the implementation of Regulation (EC) No 1881/2006 and Recommendation 2013/711/EU. They do not affect the sampling strategy, sampling levels and frequency as set out in Annexes III and IV to Council Directive 96/23/EC ⁽⁵⁾. They do not affect the targeting criteria for sampling as laid down in Commission Decision 98/179/EC ⁽⁶⁾.
- (5) It is appropriate to ensure that food business operators applying the controls performed within the framework of Article 4 of Regulation (EC) No 852/2004 of the European Parliament and of the Council ⁽⁷⁾ apply sampling procedures equivalent to the sampling procedures provided for by this Regulation in order to ensure that samples taken for those controls are representative samples. Furthermore, the European Union Reference Laboratory for Dioxins and PCBs has provided evidence that analytical results in certain cases are not reliable when the performance criteria as provided in this Regulation are not applied by laboratories performing the analysis of samples taken by food business operators within the framework of Article 4 of Regulation (EC) No 852/2004. It is therefore appropriate to make the application of the performance criteria also obligatory for the analysis of those samples.

⁽¹⁾ OJ L 165, 30.4.2004, p. 1.

⁽²⁾ Commission Regulation (EC) No 1881/2006 of 19 December 2006 setting maximum levels for certain contaminants in foodstuffs (OJ L 364, 20.12.2006, p. 5).

⁽³⁾ Commission Recommendation 2013/711/EU of 3 December 2013 on the reduction of the presence of dioxins, furans and PCBs in feed and food (OJ L 323, 4.12.2013, p. 37).

⁽⁴⁾ Commission Regulation (EU) No 589/2014 of 2 June 2014 laying down methods of sampling and analysis for the official control of levels of dioxins, dioxin-like PCBs and non-dioxin-like PCBs in certain foodstuffs and repealing Regulation (EU) No 252/2012 (OJ L 164, 3.6.2014, p. 18).

⁽⁵⁾ Council Directive 96/23/EC of 29 April 1996 on measures to monitor certain substances and residues thereof in live animals and animal products and repealing Directives 85/358/EEC and 86/469/EEC and Decisions 89/187/EEC and 91/664/EEC (OJ L 125, 23.5.1996, p. 10).

⁽⁶⁾ Commission Decision 98/179/EC of 23 February 1998 laying down detailed rules on official sampling for the monitoring of certain substances and residues thereof in live animals and animal products (OJ L 65, 5.3.1998, p. 31).

⁽⁷⁾ Regulation (EC) No 852/2004 of the European Parliament and of the Council of 29 April 2004 on the hygiene of foodstuffs (OJ L 139, 30.4.2004, p. 1).

- (6) Given that the approach of the use of a decision limit to ensure that an analytical result is above the maximum level with a certain probability, as provided for in Commission Decision 2002/657/EC ⁽¹⁾, is no longer applied for the analysis of dioxins and PCBs in food, it is appropriate to delete this approach and to keep only the approach of the expanded uncertainty using the coverage factor of 2, giving a level confidence of approximately 95 %.
- (7) In line with the reporting requirements for bioanalytical screening methods, it is appropriate to also provide for physico-chemical methods used for screening specific reporting requirements.
- (8) Given that the analysis of dioxins, dioxin-like PCBs and non-dioxin-like PCBs are in most cases determined together it is appropriate to align the performance criteria for the non-dioxin-like PCBs to the performance criteria for dioxins and dioxin-like PCBs. This is a simplification, without substantial changes in practice as in the case of non-dioxin-like PCBs the relative intensity of qualifier ions compared to target ions is > 50 %.
- (9) Furthermore there are several other minor modifications proposed to the current provisions, requiring the repeal of Regulation (EU) No 589/2014 and its replacing by a new Regulation to maintain the readability of the text.
- (10) The measures provided for in this Regulation are in accordance with the opinion of the Standing Committee on Plants, Animals, Food and Feed,

HAS ADOPTED THIS REGULATION:

Article 1

For the purposes of this Regulation, the definitions and abbreviations set out in Annex I shall apply.

Article 2

Sampling for the official control of the levels of dioxins, furans, dioxin-like PCBs and non-dioxin-like PCBs in foodstuffs listed in Section 5 of the Annex to Regulation (EC) No 1881/2006 shall be carried out in accordance with the methods set out in Annex II to this Regulation.

Article 3

Sample preparation and analyses for the control of the levels of dioxins, furans and dioxin-like PCBs in foodstuffs listed in Section 5 of the Annex to Regulation (EC) No 1881/2006 shall be carried out in accordance with the methods set out in Annex III to this Regulation.

Article 4

Analyses for the control of the levels of non-dioxin-like PCBs in foodstuffs listed in Section 5 of the Annex to Regulation (EC) No 1881/2006 shall be carried out in accordance with the requirements for analytical procedures set out in Annex IV to this Regulation.

Article 5

Regulation (EU) No 589/2014 is repealed.

References to the repealed Regulation shall be construed as references to this Regulation.

⁽¹⁾ Commission Decision 2002/657/EC of 14 August 2002 implementing Council Directive 96/23/EC concerning the performance of analytical methods and the interpretation of results (OJ L 221, 17.8.2002, p. 8).

Article 6

This Regulation shall enter into force on the twentieth day following that of its publication in the *Official Journal of the European Union*.

This Regulation shall be binding in its entirety and directly applicable in all Member States.

Done at Brussels, 5 April 2017.

For the Commission
The President
Jean-Claude JUNCKER

ANNEX I

DEFINITIONS AND ABBREVIATIONS

I. DEFINITIONS

For the purposes of this Regulation the definitions laid down in Annex I to Decision 2002/657/EC shall apply.

Further to those definitions, the following definitions shall apply for the purposes of this Regulation:

- 1.1. 'Action level' means the level of a given substance, as laid down in the Annex to Recommendation 2013/711/EU, which triggers investigations to identify the source of that substance in cases where increased levels of the substance are detected.
- 1.2. 'Screening methods' means methods used for the selection of those samples with levels of PCDD/Fs and dioxin-like PCBs that exceed the maximum levels or the action levels. They shall allow for a cost-effective high sample-throughput, thus increasing the chance of discovering new cases where high exposure may lead to health risks for consumers. Screening methods shall be based on bioanalytical or GC-MS methods. Results from samples exceeding the cut-off value established to check compliance with the maximum level shall be verified by a full re-analysis from the original sample using a confirmatory method.
- 1.3. 'Confirmatory methods' means methods that provide full or complementary information enabling the PCDD/Fs and dioxin-like PCBs to be identified and quantified unequivocally at the maximum or, in case of need, at the action level. Such methods utilise gas chromatography/high resolution mass spectrometry (GC-HRMS) or gas chromatography/tandem mass spectrometry (GC-MS/MS).
- 1.4. 'Bioanalytical methods' means methods based on the use of biological principles such as cell-based assays, receptor-assays or immunoassays. They do not give results at the congener level but merely an indication ⁽¹⁾ of the TEQ level, expressed in Bioanalytical Equivalents (BEQ) to acknowledge the fact that not all compounds present in a sample extract that produce a response in the test may meet all requirements of the TEQ-principle.
- 1.5. 'Bioassay apparent recovery' means the BEQ level calculated from the TCDD or PCB 126 calibration curve corrected for the blank and then divided by the TEQ level determined by the confirmatory method. It attempts to correct factors like the loss of PCDD/Fs and dioxin-like compounds during the extraction and clean-up steps, co-extracted compounds increasing or decreasing the response (agonistic and antagonistic effects), the quality of the curve fit, or differences between the TEF and the REP values. The bioassay apparent recovery is calculated from suitable reference samples with representative congener patterns around the maximum or action level.
- 1.6. 'Duplicate analysis' means separate analysis of the analytes of interest using a second aliquot of the same homogenised sample.
- 1.7. 'Accepted specific limit of quantification ⁽²⁾ of an individual congener in a sample' means the lowest content of the analyte that can be measured with reasonable statistical certainty, fulfilling the identification criteria as described in internationally recognised standards, for example, in standard EN 16215:2012 ('Animal feed — Determination of dioxins and dioxin-like PCBs by GC/HRMS and of indicator PCBs by GC/HRMS') and/or in EPA methods 1613 and 1668 as revised.

The limit of quantification of an individual congener may be identified as

- (a) the concentration of an analyte in the extract of a sample which produces an instrumental response at two different ions to be monitored with a S/N (signal/noise) ratio of 3:1 for the less intensive raw data signal;

⁽¹⁾ Bioanalytical methods are not specific to those congeners included in the TEF-scheme. Other structurally related AhR-active compounds may be present in the sample extract which contribute to the overall response. Therefore, bioanalytical results cannot be an estimate but rather an indication of the TEQ level in the sample.

⁽²⁾ The principles as described in the 'Guidance Document on the Estimation of LOD and LOQ for Measurements in the Field of Contaminants in Feed and Food' [[link to website](#)] shall be followed when applicable.

or, if for technical reasons the signal-to-noise calculation does not provide reliable results,

(b) the lowest concentration point on a calibration curve that gives an acceptable ($\leq 30\%$) and consistent (measured at least at the start and at the end of an analytical series of samples) deviation to the average relative response factor calculated for all points on the calibration curve in each series of samples⁽¹⁾.

- 1.8. 'Upper-bound' means the concept which requires using the limit of quantification for the contribution of each non-quantified congener.
- 1.9. 'Lower-bound' means the concept which requires using zero for the contribution of each non-quantified congener.
- 1.10. 'Medium-bound' means the concept which requires using half of the limit of quantification calculating the contribution of each non-quantified congener.
- 1.11. 'Lot' means an identifiable quantity of food delivered at one time and determined by the official to have common characteristics, such as origin, variety, type of packing, packer, consignor or markings. In the case of fish and fishery products, also the size of fish shall be comparable. In case the size and/or weight of the fish is not comparable within a consignment, the consignment may still be considered as a lot but a specific sampling procedure has to be applied.
- 1.12. 'Sublot' means designated part of a large lot in order to apply the sampling method on that designated part. Each sublot must be physically separated and identifiable.
- 1.13. 'Incremental sample' means a quantity of material taken from a single place in the lot or sublot.
- 1.14. 'Aggregate sample' means the combined total of all the incremental samples taken from the lot or sublot.
- 1.15. 'Laboratory sample' means a representative part/quantity of the aggregate sample intended for the laboratory.

II. ABBREVIATIONS USED

BEQ	Bioanalytical Equivalents
GC	Gas chromatography
HRMS	High resolution mass spectrometry
LRMS	Low resolution mass spectrometry
MS/MS	Tandem mass spectrometry
PCB	Polychlorinated biphenyl
Non-dioxin-like PCBs	PCB 28, PCB 52, PCB 101, PCB 138, PCB 153 and PCB 180
PCDD	Polychlorinated dibenzo-p-dioxins
PCDF	Polychlorinated dibenzofurans
QC	Quality control
REP	Relative potency
TEF	Toxic Equivalency Factor
TEQ	Toxic Equivalents
TCDD	2,3,7,8-Tetrachlorodibenzo-p-dioxin
U	Expanded measurement uncertainty

⁽¹⁾ The LOQ is calculated from the lowest concentration point taking into account the recovery of internal standards and sample intake.

ANNEX II

METHODS OF SAMPLING FOR OFFICIAL CONTROL OF LEVELS OF DIOXINS (PCDD/PCDF), DIOXIN-LIKE PCBs AND NON-DIOXIN-LIKE PCBs IN CERTAIN FOODSTUFFS**I. SCOPE**

Samples intended for the official control of the levels of dioxins (PCDD/Fs), dioxin-like PCBs and non-dioxin-like PCBs in foodstuffs shall be taken according to the methods described in this Annex. Aggregate samples thus obtained shall be considered as representative of the lots or sublots from which they are taken. Compliance with maximum levels laid down in Regulation (EC) No 1881/2006 shall be established on the basis of the levels determined in the laboratory samples.

To ensure compliance with the provisions in Article 4 of Regulation (EC) No 852/2004, food business operator shall, when samples are taken to control the levels of dioxins (PCDD/Fs), dioxin-like PCBs and non-dioxin-like PCBs, take the samples according to the methods described in Chapter III of this Annex or apply an equivalent sampling procedure which is demonstrated to have a same level of representation as the sampling procedure described in Chapter III of this Annex.

II. GENERAL PROVISIONS**1. Personnel**

Official sampling shall be performed by an authorised person as designated by the Member State.

2. Material to be sampled

Each lot or subplot which is to be examined shall be sampled separately.

3. Precautions to be taken

In the course of sampling and the preparation of the samples, precautions shall be taken to avoid any changes which would affect the content of dioxins and PCBs, adversely affect the analytical determination or make the aggregate samples unrepresentative.

4. Incremental samples

As far as possible, incremental samples shall be taken at various places distributed throughout the lot or subplot. Departure from such a procedure shall be recorded in the record provided for under point II.8.

5. Preparation of the aggregate sample

The aggregate sample shall be made up by combining the incremental samples. It shall be at least 1 kg unless not practical, e.g. when a single package has been sampled or when the product has a very high commercial value.

6. Replicate samples

The replicate samples for enforcement, defence and reference purposes shall be taken from the homogenised aggregate sample, unless such procedure conflicts with a Member State's rules as regard the rights of the food business operator. The size of the laboratory samples for enforcement shall be sufficient to allow at least for duplicate analyses.

7. Packaging and transmission of samples

Each sample shall be placed in a clean, inert container offering adequate protection from contamination, from loss of analytes by adsorption to the internal wall of the container and against damage in transit. All necessary precautions shall be taken to avoid any change in composition of the sample which might arise during transportation or storage.

8. Sealing and labelling of samples

Each sample taken for official use shall be sealed at the place of sampling and identified in accordance with the rules of the Member States.

A record shall be kept of each sampling, permitting each lot to be identified unambiguously and giving the date and place of sampling together with any additional information likely to be of assistance to the analyst.

III. SAMPLING PLAN

The sampling method applied shall ensure that the aggregate sample is representative of the (sub)lot that is to be controlled.

1. Division of lots into sublots

Large lots shall be divided into sublots on condition that the subplot can be separated physically. For products traded in large bulk consignments (e.g. vegetable oils) Table 1 shall apply. For other products Table 2 shall apply. Taking into account that the weight of the lot is not always an exact multiple of the weight of the sublots, the weight of the subplot may exceed the mentioned weight by a maximum of 20 %.

Table 1

Subdivision of lots into sublots for products traded in bulk consignments

Lot weight (ton)	Weight or number of sublots
≥ 1 500	500 tonnes
> 300 and < 1 500	3 sublots
≥ 50 and ≤ 300	100 tonnes
< 50	—

Table 2

Subdivision of lots into sublots for other products

Lot weight (ton)	Weight or number of sublots
≥ 15	15-30 tonnes
< 15	—

2. Number of incremental samples

The aggregate sample uniting all incremental samples shall be at least 1 kg (see point II.5).

The minimum number of incremental samples to be taken from the lot or subplot shall be as given in Tables 3 and 4.

In the case of bulk liquid products, the lot or subplot shall be thoroughly mixed insofar as possible and insofar as it does not affect the quality of the product by either manual or mechanical means immediately prior to sampling. In that case, a homogeneous distribution of contaminants is assumed within a given lot or subplot. It is therefore sufficient to take three incremental samples from a lot or subplot to form the aggregate sample.

The incremental samples shall be of similar weight. The weight of an incremental sample shall be at least 100 grams.

Departure from this procedure must be recorded in the record provided for under point II.8 of this Annex. In accordance with the provisions of Commission Decision 97/747/EC⁽¹⁾, the aggregate sample size for hens' eggs is at least 12 eggs (for bulk lots as well as for lots consisting of individual packages, Tables 3 and 4 shall apply).

Table 3

Minimum number of incremental samples to be taken from the lot or subplot

Weight or volume of lot/sublot (in kg or litre)	Minimum number of incremental samples to be taken
< 50	3
50 to 500	5
> 500	10

If the lot or subplot consists of individual packages or units, then the number of packages or units which shall be taken to form the aggregate sample is given in Table 4.

Table 4

Number of packages or units (incremental samples) which shall be taken to form the aggregate sample if the lot or subplot consists of individual packages or units

Number of packages or units in the lot/sublot	Number of packages or units to be taken
1 to 25	at least 1 package or unit
26 to 100	about 5 %, at least 2 packages or units
> 100	about 5 %, at maximum 10 packages or units

3. Specific provisions for the sampling of lots containing whole fishes of comparable size and weight

Fishes are considered to be of comparable size and weight where the difference in size and weight does not exceed about 50 %.

The number of incremental samples to be taken from the lot are defined in Table 3. The aggregate sample uniting all incremental samples shall be at least 1 kg (see point II.5).

— Where the lot to be sampled contains small fishes (individual fishes weighing < about 1 kg), the whole fish is taken as incremental sample to form the aggregate sample. Where the resulting aggregate sample weighs more than 3 kg, the incremental samples may consist of the middle part, weighing each at least 100 grams, of the fishes forming the aggregate sample. The whole part to which the maximum level is applicable is used for homogenisation of the sample.

The middle part of the fish is where the centre of gravity is. This is located in most cases at the dorsal fin (in case the fish has a dorsal fin) or halfway between the gill opening and the anus.

— Where the lot to be sampled contains larger fishes (individual fishes weighing more than about 1 kg), the incremental sample consists of the middle part of the fish. Each incremental sample weighs at least 100 grams.

For fishes of intermediate size (about 1-6 kg) the incremental sample is taken as a slice of the fish from backbone to belly in the middle part of the fish.

⁽¹⁾ Commission Decision 97/747/EC of 27 October 1997 fixing the levels and frequencies of sampling provided for by Council Directive 96/23/EC for the monitoring of certain substances and residues thereof in certain animal products (OJ L 303, 6.11.1997, p. 12).

For very large fishes (e.g. > about 6 kg), the incremental part is taken from the right side (frontal view) dorso-lateral muscle meat in the middle part of the fish. Where the taking of such a piece of the middle part of the fish would result in significant economic damage, the taking of three incremental samples of at least 350 grams each may be considered as being sufficient independent of the size of the lot or alternatively an equal part of the muscled meat close to the tail part and the muscle meat close to the head part of one fish may be taken to form the incremental sample being representative for the level of dioxins in the whole fish.

4. Sampling of lots of fish containing whole fishes of different size and/or weight

- The provisions of point III.3 as regards sample constitution shall apply.
- Where a size or weight class/category is predominant (about 80 % or more of the lot), the sample is taken from fishes with the predominant size or weight. This sample is to be considered as being representative for the whole lot.
- Where no particular size or weight class/category predominates, then it must be ensured that the fishes selected for the sample are representative for the lot. Specific guidance for such cases is provided in 'Guidance document on sampling of whole fishes of different size and/or weight' ⁽²⁾.

5. Sampling at retail stage

Sampling of foodstuffs at the retail stage shall be done where possible in accordance with the sampling provisions set out in point III.2.

Where this is not possible, an alternative method of sampling at retail stage may be used provided that it ensures sufficient representativeness for the sampled lot or subplot.

IV. COMPLIANCE OF THE LOT WITH SPECIFICATION

1. As regards non-dioxin-like PCBs

The lot is compliant if the analytical result for the sum of non-dioxin-like PCBs does not exceed the respective maximum level, as laid down in Regulation (EC) No 1881/2006 taking into account the expanded measurement uncertainty ⁽³⁾.

The lot is non-compliant with the maximum level as laid down in Regulation (EC) No 1881/2006 if the mean of two upperbound analytical results obtained from duplicate analysis ⁽⁴⁾, taking into account the expanded measurement uncertainty, exceeds the maximum level beyond reasonable doubt.

The expanded measurement uncertainty is calculated using a coverage factor of 2 which gives a level of confidence of approximately 95 %. A lot is non-compliant if the mean of the measured values minus the expanded uncertainty of the mean is above the established maximum level.

The rules, mentioned in the paragraphs above under this point, shall apply for the analytical result obtained on the sample for official control. In case of analysis for defence or reference purposes, the national rules apply.

2. As regards dioxins (PCDD/Fs) and dioxin-like PCBs

The lot is compliant if the result of a single analysis

- performed by a screening method with a false-compliant rate below 5 % indicates that the level does not exceed the respective maximum level of PCDD/Fs and the sum of PCDD/Fs and dioxin-like PCBs as laid down in Regulation (EC) No 1881/2006,

⁽²⁾ https://ec.europa.eu/food/sites/food/files/safety/docs/cs_contaminants_catalogue_dioxins_guidance-sampling_exampl-es-dec2006_en.pdf

⁽³⁾ The principles as described in the 'Guidance Document on Measurement Uncertainty for Laboratories performing PCDD/F and PCB Analysis using Isotope Dilution Mass Spectrometry' [link to website] shall be followed when applicable.

⁽⁴⁾ The duplicate analysis is necessary if the result of the first determination is non-compliant. The duplicate analysis is necessary to exclude the possibility of internal cross-contamination or an accidental mix-up of samples. In case the analysis is performed in the course of a contamination incident, confirmation by duplicate analysis might be omitted in case the samples selected for analysis are through traceability linked to the contamination incident and the level found is significantly above the maximum level.

- performed by a confirmatory method does not exceed the respective maximum level of PCDD/Fs and the sum of PCDD/Fs and dioxin-like PCBs as laid down in Regulation (EC) No 1881/2006 taking into account the expanded measurement uncertainty ⁽⁷⁾.

For screening assays a cut-off value shall be established for the decision on the compliance with the respective maximum levels set for either PCDD/Fs or for the sum of PCDD/Fs and dioxin-like PCBs.

The lot is non-compliant with the maximum level as laid down in Regulation (EC) No 1881/2006 if the mean of two upperbound analytical results (duplicate analysis ⁽⁸⁾) obtained using a confirmatory method, taking into account the expanded measurement uncertainty, exceeds the maximum level beyond reasonable doubt.

The expanded measurement uncertainty is calculated using a coverage factor of 2 which gives a level of confidence of approximately 95 %. A lot is non-compliant if the mean of the measured values minus the expanded uncertainty of the mean is above the established maximum level.

The sum of the estimated expanded uncertainties of the separate analytical results of PCDD/Fs and dioxin-like PCBs has to be used for the estimated expanded uncertainty of the sum of PCDD/Fs and dioxin-like PCBs,

The rules, mentioned in the paragraphs above under this point, shall apply for the analytical result obtained on the sample for official control. In case of analysis for defence or reference purposes, the national rules apply.

V. EXCEEDANCE OF ACTION LEVELS

Action levels serve as a tool for the selection of samples in those cases where it is appropriate to identify a source of contamination and to take measures for its reduction or elimination. Screening methods shall establish the appropriate cut-off values for selection of those samples. Where significant efforts are necessary to identify a source and to reduce or eliminate the contamination, it might be appropriate to confirm exceedance of the action level by duplicate analysis using a confirmatory method and taking into account the expanded measurement uncertainty ⁽⁷⁾.

⁽⁷⁾ Guidance Document on Measurement Uncertainty for Laboratories performing PCDD/F and PCB Analysis using Isotope Dilution Mass Spectrometry [[link to website](#)], Guidance Document on the Estimation of LOD and LOQ for Measurements in the Field of Contaminants in Feed and Food [[link to website](#)].

⁽⁸⁾ The duplicate analysis is necessary if the result of the first determination applying confirmatory methods with the use of ¹³C-labelled internal standard for the relevant analytes is non-compliant. The duplicate analysis is necessary to exclude the possibility of internal cross-contamination or an accidental mix-up of samples. In case the analysis is performed in the course of a contamination incident, confirmation by duplicate analysis might be omitted in case the samples selected for analysis are through traceability linked to the contamination incident and the level found is significantly above the maximum level.

⁽⁷⁾ Identical explanation and requirements for duplicate analysis for control of action levels as in footnote 6 for maximum levels.

ANNEX III

SAMPLE PREPARATION AND REQUIREMENTS FOR METHODS OF ANALYSIS USED IN CONTROL OF THE LEVELS OF DIOXINS (PCDD/Fs) AND DIOXIN-LIKE PCBs IN CERTAIN FOODSTUFFS**1. FIELD OF APPLICATION**

The requirements set out in this Annex shall be applied where foodstuffs are analysed for the official control of the levels of 2,3,7,8-substituted polychlorinated dibenzo-p-dioxins and polychlorinated dibenzofurans (PCDD/Fs) and dioxin-like polychlorinated biphenyls (dioxin-like PCBs) and as regards sample preparation and analytical requirements for other regulatory purposes, including the controls performed by the food business operator to ensure compliance with provisions in Article 4 of Regulation (EC) No 852/2004.

Monitoring for the presence of PCDD/Fs and dioxin-like PCBs in foodstuffs may be performed with two different types of analytical methods:

(a) Screening methods

The goal of screening methods is to select those samples with levels of PCDD/Fs and dioxin-like PCBs that exceed the maximum levels or the action levels. Screening methods shall ensure cost-effective high sample-throughput, thus increasing the chance to discover new incidents where high exposure may lead to health risks for consumers. Their application shall aim to avoid false-compliant results. They may comprise bioanalytical and GC/MS methods.

Screening methods compare the analytical result with a cut-off value, providing a yes/no-decision over the possible exceedance of the maximum or action level. The concentration of PCDD/Fs and the sum of PCDD/Fs and dioxin-like PCBs in samples suspected to be non-compliant with the maximum level must be determined or confirmed by a confirmatory method.

In addition, screening methods may give an indication of the levels of PCDD/Fs and dioxin-like-PCBs present in the sample. In case of application of bioanalytical screening methods the result is expressed as Bioanalytical Equivalents (BEQ), whereas in case of application of physico-chemical GC-MS methods it is expressed as Toxic Equivalents (TEQ). The numerically indicated results of screening methods are suitable for demonstrating compliance or suspected non-compliance or exceedance of action levels and give an indication of the range of levels in case of follow-up by confirmatory methods. They are not suitable for purposes such as evaluation of background levels, estimation of intake, following of time trends in levels or re-evaluation of action and maximum levels.

(b) Confirmatory methods

Confirmatory methods allow the unequivocal identification and quantification of PCDD/Fs and dioxin-like PCBs present in a sample and provide full information on congener basis. Therefore, those methods allow the control of maximum and action levels, including the confirmation of results obtained by screening methods. Furthermore, results may be used for other purposes such as determination of low background levels in food monitoring, following of time trends, exposure assessment of the population and building of a database for possible re-evaluation of action and maximum levels. They are also important for establishing congener patterns in order to identify the source of a possible contamination. Such methods utilise GC-HRMS. For confirming compliance or non-compliance with the maximum level, also GC-MS/MS can be used.

2. BACKGROUND

For calculation of TEQ concentrations, the concentrations of the individual substances in a given sample shall be multiplied by their respective TEF, as established by the World Health Organisation and listed in the Appendix to this Annex, and subsequently summed to give the total concentration of dioxin-like compounds expressed as TEQs.

Screening and confirmatory methods may only be applied for control of a certain matrix if the methods are sensitive enough to detect levels reliably at the maximum or action level.

3. QUALITY ASSURANCE REQUIREMENTS

- Measures must be taken to avoid cross-contamination at each stage of the sampling and analysis procedure.
- The samples must be stored and transported in glass, aluminum, polypropylene or polyethylene containers suitable for storage without any influence on the levels of PCDD/Fs and dioxin-like PCBs in the samples. Traces of paper dust must be removed from the sample container.
- The sample storage and transportation has to be performed in a way that maintains the integrity of the foodstuff sample.
- Insofar as relevant, finely grind and mix thoroughly each laboratory sample using a process that has been demonstrated to achieve complete homogenisation (e.g. ground to pass a 1 mm sieve); samples have to be dried before grinding if moisture content is too high.
- Control of reagents, glassware and equipment for possible influence of TEQ- or BEQ-based results is of general importance.
- A blank analysis shall be performed by carrying out the entire analytical procedure omitting only the sample.
- For bioanalytical methods, it is of great importance that all glassware and solvents used in analysis shall be tested to be free of compounds that interfere with the detection of target compounds in the working range. Glassware shall be rinsed with solvents or/and heated at temperatures suitable to remove traces of PCDD/Fs, dioxin-like compounds and interfering compounds from its surface.
- Sample quantity used for the extraction must be sufficient to fulfill the requirements with respect to a sufficiently low working range including the concentrations of maximum or action levels.
- The specific sample preparation procedures used for the products under consideration shall follow internationally accepted guidelines.
- In the case of fish, the skin has to be removed as the maximum level applies to muscle meat without skin. However it is necessary that all remaining muscle meat and fat tissue on the inner side of the skin are carefully and completely scraped off from the skin and added to the sample to be analysed.

4. REQUIREMENTS FOR LABORATORIES

- In accordance with the provisions of Regulation (EC) No 882/2004, laboratories shall be accredited by a recognised body operating in accordance with ISO Guide 58 to ensure that they are applying analytical quality assurance. Laboratories shall be accredited following the EN ISO/IEC 17025 standard. The principles as described in the Technical Guidelines for the estimation of measurement uncertainty and limits of quantification for PCDD/F and PCB analysis shall be followed when applicable ⁽¹⁾.
- Laboratory proficiency shall be proven by the continuous successful participation in interlaboratory studies for the determination of PCDD/Fs and dioxin-like PCBs in relevant food matrices and concentration ranges.
- Laboratories applying screening methods for routine control of samples shall establish a close cooperation with laboratories applying the confirmatory method, both for quality control and confirmation of the analytical result of suspected samples.

5. BASIC REQUIREMENTS TO BE MET BY ANALYTICAL PROCEDURE FOR DIOXINS (PCDD/Fs) AND DIOXIN-LIKE PCBs

5.1. Low working range and limits of quantification

- For PCDD/Fs, detectable quantities have to be in the upper femtogram (10^{-15} g) range because of extreme toxicity of some of these compounds. For most PCB congeners limit of quantification in the nanogram (10^{-9} g) range is already sufficient. However, for the measurement of the more toxic dioxin-like PCB congeners (in particular non-ortho-substituted congeners) the lower end of the working range must reach the low picogram (10^{-12} g) levels.

⁽¹⁾ Guidance Document on Measurement Uncertainty for Laboratories performing PCDD/F and PCB Analysis using Isotope Dilution Mass Spectrometry [link to website], Guidance Document on the Estimation of LOD and LOQ for Measurements in the Field of Contaminants in Feed and Food [link to website].

5.2. High selectivity (specificity)

- A distinction is required between PCDD/Fs and dioxin-like PCBs and a multitude of other, coextracted and possibly interfering compounds present at concentrations up to several orders of magnitude higher than those of the analytes of interest. For gas chromatography/mass spectrometry (GC-MS) methods, a differentiation among various congeners is necessary, such as between toxic (e.g. the seventeen 2,3,7,8-substituted PCDD/Fs, and twelve dioxin-like PCBs) and other congeners.
- Bioanalytical methods shall be able to detect the target compounds as the sum of PCDD/Fs, and/or dioxin-like PCBs. Sample clean-up shall aim at removing compounds causing false non-compliant results or compounds that may decrease the response, causing false-compliant results.

5.3. High accuracy (trueness and precision, bioassay apparent recovery)

- For GC-MS methods, the determination shall provide a valid estimate of the true concentration in a sample. High accuracy (accuracy of the measurement: the closeness of the agreement between the result of a measurement with the true or assigned value of the measurand) is necessary to avoid the rejection of a sample analysis result on the basis of poor reliability of the determined TEQ level. Accuracy is expressed as trueness (difference between the mean value measured for an analyte in a certified material and its certified value, expressed as percentage of this value) and precision (RSD_R relative standard deviation calculated from results generated under reproducibility conditions).
- For bioanalytical methods, the bioassay apparent recovery shall be determined.

5.4. Validation in the range of maximum level and general quality control measures

- Laboratories shall demonstrate the performance of a method in the range of the maximum level, e.g. 0,5×, 1× and 2× the maximum level with an acceptable coefficient of variation for repeated analysis, during the validation procedure and/or during routine analysis.
- Regular blank controls and spiking experiments or analysis of control samples (preferably, if available, certified reference material) shall be performed as internal quality control measures. Quality control (QC) charts for blank controls, spiking experiments or analysis of control samples shall be recorded and checked to make sure the analytical performance is in accordance with the requirements.

5.5. Limit of quantification

- For a bioanalytical screening method, establishment of the LOQ is not an indispensable requirement but the method shall prove that it can differentiate between the blank and the cut-off value. When providing a BEQ-level, a reporting level shall be established to deal with samples showing a response below this level. The reporting level shall be demonstrated to be different from procedure blank samples at least by a factor of three, with a response below the working range. It shall therefore be calculated from samples containing the target compounds around the required minimum level, and not from a S/N ratio or an assay blank.
- Limit of quantification (LOQ) for a confirmatory method shall be about one fifth of the maximum level.

5.6. Analytical criteria

- For reliable results from confirmatory or screening methods, the following criteria must be met in the range of the maximum level for the TEQ value respectively the BEQ value, whether determined as total TEQ or total BEQ (as sum of PCDD/F and dioxin-like PCBs) or separately for PCDD/Fs and dioxin-like PCBs.

	Screening with bioanalytical or physico-chemical methods	Confirmatory methods
False-compliant rate (*)	< 5 %	
Trueness		- 20 % to + 20 %

	Screening with bioanalytical or physico-chemical methods	Confirmatory methods
Repeatability (RSD _r)	< 20 %	
Intermediate precision (RSD _R)	< 25 %	< 15 %

(*) With respect to the maximum levels

5.7. Specific requirements for screening methods

- Both GC-MS and bioanalytical methods may be used for screening. For GC-MS methods the requirements as laid down in point 6 are to be used. For cell-based bioanalytical methods specific requirements are laid down in point 7.
- Laboratories applying screening methods for routine control of samples shall establish a close cooperation with laboratories applying the confirmatory method.
- Performance verification of the screening method is required during routine analysis, by analytical quality control and ongoing method validation. There must be a continuous programme for control of compliant results.
- Check on possible suppression of the cell response and cytotoxicity.

20 % of the sample extracts shall be measured in routine screening without and with TCDD added corresponding to the maximum or action level, to check if the response is possibly suppressed by interfering substances present in the sample extract. The measured concentration of the spiked sample is compared to the sum of the concentration of the unspiked extract plus the spiking concentration. If this measured concentration is more than 25 % lower than the calculated (sum) concentration, this is an indication of a potential signal suppression and the respective sample must be submitted to confirmatory analysis. Results shall be monitored in quality control charts.

- Quality control on compliant samples

Approximately 2 % to 10 % of the compliant samples, depending on sample matrix and laboratory experience, shall be confirmed.

- Determination of false-compliant rates from QC data

The rate of false-compliant results from screening of samples below and above the maximum level or the action level shall be determined. Actual false-compliant rates shall be below 5 %.

After a minimum of 20 confirmed results per matrix/matrix group is available from the quality control of compliant samples, conclusions on the false-compliant rate shall be drawn from this database. The results from samples analysed in ring trials or during contamination incidents, covering a concentration range up to, e.g. 2× the maximum level (ML), may also be included in the minimum of 20 results for evaluation of the false-compliant rate. The samples shall cover most frequent congener patterns, representing various sources.

Although screening assays shall preferentially aim to detect samples exceeding the action level, the criterion for determining false-compliant rates is the maximum level, taking into account the expanded measurement uncertainty of the confirmatory method.

- Potential non-compliant results from screening shall always be verified by a full re-analysis of the original sample by a confirmatory method. These samples may also be used to evaluate the rate of false non-compliant results. For screening methods, the rate of false non-compliant results is the fraction of results confirmed to be compliant from confirmatory analysis, while in previous screening the sample had been declared to be suspected to be non-compliant. However, evaluation of the advantageousness of the screening method shall be based on comparison of false non-compliant samples with the total number of samples checked. This rate shall be low enough to make the use of a screening tool advantageous.

- At least under validation conditions, bioanalytical methods shall provide a valid indication of the TEQ level, calculated and expressed as BEQ.
 - Also for bioanalytical methods carried out under repeatability conditions, the intra-laboratory RSD_r would typically be smaller than the reproducibility RSD_R.
6. SPECIFIC REQUIREMENTS FOR GC-MS METHODS TO BE COMPLIED WITH FOR SCREENING OR CONFIRMATORY PURPOSES
- 6.1. **Acceptable differences between upperbound and lowerbound WHO-TEQ levels**
- The difference between upperbound level and lowerbound level shall not exceed 20 % for confirmation of the exceedance of maximum or in case of need of action levels.
- 6.2. **Control of recoveries**
- Addition of ¹³C-labelled 2,3,7,8-chlorine-substituted internal PCDD/F standards and of ¹³C-labelled internal dioxin-like PCB standards must be carried out at the very beginning of the analytical method, e.g. prior to extraction, in order to validate the analytical procedure. At least one congener for each of the tetra- to octa-chlorinated homologous groups for PCDD/Fs and at least one congener for each of the homologous groups for dioxin-like PCBs must be added (alternatively, at least one congener for each mass spectrometric selected ion recording function used for monitoring PCDD/Fs and dioxin-like PCBs). In case of confirmatory methods, all seventeen ¹³C-labelled 2,3,7,8-substituted internal PCDD/F standards and all twelve ¹³C-labelled internal dioxin-like PCB standards shall be used.
 - Relative response factors shall also be determined for those congeners for which no ¹³C-labelled analogue is added by using appropriate calibration solutions.
 - For foodstuffs of plant origin and foodstuffs of animal origin containing less than 10 % fat, the addition of the internal standards is mandatory prior to extraction. For foodstuffs of animal origin containing more than 10 % fat, the internal standards may be added either before or after fat extraction. An appropriate validation of the extraction efficiency shall be carried out, depending on the stage at which internal standards are introduced and on whether results are reported on product or fat basis.
 - Prior to GC-MS analysis, one or two recovery (surrogate) standard(s) must be added.
 - Control of recovery is necessary. For confirmatory methods, the recoveries of the individual internal standards shall be in the range of 60 to 120 %. Lower or higher recoveries for individual congeners, in particular for some hepta- and octa- chlorinated dibenzo-p-dioxins and dibenzofurans, are acceptable on the condition that their contribution to the TEQ value does not exceed 10 % of the total TEQ value (based on sum of PCDD/F and dioxin-like PCBs). For GC-MS screening methods, the recoveries shall be in the range of 30 to 140 %.
- 6.3. **Removal of interfering substances**
- Separation of PCDD/Fs from interfering chlorinated compounds such as non-dioxin-like PCBs and chlorinated diphenyl ethers shall be carried out by suitable chromatographic techniques (preferably with a florisil, alumina and/or carbon column).
 - Gas-chromatographic separation of isomers shall be sufficient (< 25 % peak to peak between 1,2,3,4,7,8-HxCDF and 1,2,3,6,7,8-HxCDF).
- 6.4. **Calibration with standard curve**
- The range of the calibration curve shall cover the relevant range of maximum or action levels.
- 6.5. **Specific criteria for confirmatory methods**
- For GC-HRMS:

In HRMS, the resolution shall typically be greater than or equal to 10 000 for the entire mass range at 10 % valley.

Fulfilment of further identification and confirmation criteria as described in internationally recognised standards, for example, in standard EN 16215:2012 (Animal feed — Determination of dioxins and dioxin-like PCBs by GC/HRMS and of indicator PCBs by GC/HRMS) and/or in EPA methods 1613 and 1668 as revised.

— For GC-MS/MS:

Monitoring of at least two specific precursor ions, each with one specific corresponding transition product ion for all labelled and unlabelled analytes in the scope of analysis.

Maximum permitted tolerance of relative ion intensities of $\pm 15\%$ for selected transition product ions in comparison to calculated or measured values (average from calibration standards), applying identical MS/MS conditions, in particular collision energy and collision gas pressure, for each transition of an analyte.

Resolution for each quadrupole to be set equal to or better than unit mass resolution (unit mass resolution: sufficient resolution to separate two peaks one mass unit apart) in order to minimise possible interferences on the analytes of interest.

Fulfilment of the further criteria as described in internationally recognised standards, for example, in standard EN 16215:2012 (Animal feed — Determination of dioxins and dioxin-like PCBs by GC/HRMS and of indicator PCBs by GC/HRMS) and/or in EPA methods 1613 and 1668 as revised, except the obligation to use GC-HRMS.

7. SPECIFIC REQUIREMENTS FOR BIOANALYTICAL METHODS

Bioanalytical methods are methods based on the use of biological principles like cell-based assays, receptor-assays or immunoassays. This point establishes requirements for bioanalytical methods in general.

A screening method in principle classifies a sample as compliant or suspected to be non-compliant. For this, the calculated BEQ level is compared to the cut-off value (see point 7.3). Samples below the cut-off value are declared compliant, samples equal or above the cut-off value as suspected to be non-compliant, requiring analysis by a confirmatory method. In practice, a BEQ level corresponding to two-thirds of the maximum level may serve as cut-off value provided that a false-compliant rate below 5 % and an acceptable rate for false non-compliant results are ensured. With separate maximum levels for PCDD/Fs and for the sum of PCDD/Fs and dioxin-like PCBs, checking compliance of samples without fractionation requires appropriate bioassay cut-off values for PCDD/Fs. For checking of samples exceeding the action levels, an appropriate percentage of the respective action level would suit as cut-off value.

If an indicative level is expressed in BEQs, the results from the the sample must be given in the working range and exceeding the reporting limit (see points 7.1.1 and 7.1.6).

7.1. Evaluation of the test response

7.1.1. General requirements

— When calculating the concentrations from a TCDD calibration curve, values at the higher end of the curve will show a high variation (high coefficient of variation (CV)). The working range is the area where this CV is smaller than 15 %. The lower end of the working range (reporting limit) must further be set significantly (at least by a factor of three) above the procedure blanks. The upper end of the working range is usually represented by the EC_{70} value (70 % of maximal effective concentration), but lower if the CV is higher than 15 % in this range. The working range shall be established during validation. Cut-off values (see point 7.3) must be within the working range.

— Standard solutions and sample extracts shall be tested in triplicate or at least in duplicate. When using duplicates, a standard solution or a control extract tested in four to six wells divided over the plate shall produce a response or concentration (only possible in the working range) based on a $CV < 15\%$.

7.1.2. Calibration

7.1.2.1. Calibration with standard curve

- Levels in samples may be estimated by comparison of the test response with a calibration curve of TCDD (or PCB 126 or a PCDD/F/dioxin-like PCB standard mixture) to calculate the BEQ level in the extract and subsequently in the sample.
- Calibration curves shall contain 8 to 12 concentrations (at least in duplicates), with enough concentrations in the lower part of the curve (working range). Special attention shall be paid to the quality of the curve-fit in the working range. As such, the R^2 value is of little or no value in estimating the goodness of fit in nonlinear regression. A better fit will be achieved by minimising the difference between calculated and observed levels in the working range of the curve (e.g. by minimising the sum of squared residuals).
- The estimated level in the sample extract is subsequently corrected for the BEQ level calculated for a matrix or solvent blank sample (to account for impurities from solvents and chemicals used), and the apparent recovery (calculated from the BEQ level of suitable reference samples with representative congener patterns around the maximum or action level). For performing a recovery correction, the apparent recovery must always be within the required range (see point 7.1.4). Reference samples used for recovery correction must comply with requirements as given in point 7.2.

7.1.2.2. Calibration with reference samples

Alternatively, a calibration curve prepared from at least four reference samples (see point 7.2: one matrix blank, plus three reference samples at 0,5×, 1,0× and 2,0× the maximum or action level may be used, eliminating the need to correct for blank and recovery if matrix properties of the reference samples match those of the unknown samples. In this case, the test response corresponding to two-thirds of the maximum level (see point 7.3) may be calculated directly from these samples and used as cut-off value. For checking of samples exceeding the action levels, an appropriate percentage of these action levels would suit as cut-off value.

7.1.3. Separate determination of PCDD/Fs and dioxin-like PCBs

Extracts may be split into fractions containing PCDD/Fs and dioxin-like PCBs, allowing a separate indication of PCDD/Fs and dioxin-like PCB TEQ levels (in BEQs). A PCB 126 standard calibration curve shall preferentially be used to evaluate results for the fraction containing dioxin-like PCBs.

7.1.4. Bioassay apparent recoveries

The 'bioassay apparent recovery' shall be calculated from suitable reference samples with representative congener patterns around the maximum or action level and expressed as percentage of the BEQ level in comparison to the TEQ level. Depending on the type of assay and TEFs⁽¹⁾ used, the differences between TEF and REP factors for dioxin-like PCBs may cause low apparent recoveries for dioxin-like PCBs in comparison to PCDD/Fs. Therefore, if a separate determination of PCDD/Fs and dioxin-like PCBs is performed, bioassay apparent recoveries shall be: for dioxin-like PCBs 20 % to 60 %, for PCDD/Fs 50 % to 130 % (ranges apply for TCDD calibration curve). As the contribution of dioxin-like PCBs to the sum of PCDD/Fs and dioxin-like PCBs may vary between different matrices and samples, bioassay apparent recoveries for the sum parameter reflect these ranges and shall be between 30 % to 130 %.

7.1.5. Control of recoveries for clean-up

The loss of compounds during the clean-up shall be checked during validation. A blank sample spiked with a mixture of the different congeners shall be submitted to clean-up (at least $n = 3$) and the recovery and variability checked by a confirmatory method. The recovery shall be within 60 to 120 % especially for congeners contributing more than 10 % to the TEQ-level in various mixtures.

⁽¹⁾ Current requirements are based on the TEFs published in: M. Van den Berg et al, Toxicol Sci 93 (2), 223-241 (2006).

7.1.6. Reporting Limit

When reporting BEQ levels, a reporting limit shall be determined from relevant matrix samples involving typical congener patterns, but not from the calibration curve of the standards due to low precision in the lower range of the curve. Effects from extraction and clean-up must be taken into account. The reporting limit must be set significantly (at least by a factor of three) above the procedure blanks.

7.2. Use of reference samples

- Reference samples shall represent sample matrix, congener patterns and concentration ranges for PCDD/Fs and dioxin-like PCBs around the maximum or action level.
- A procedure blank, or preferably a matrix blank, and a reference sample at the maximum or action level have to be included in each test series. These samples must be extracted and tested at the same time under identical conditions. The reference sample must show a clearly elevated response in comparison to the blank sample, thus ensuring the suitability of the test. Those samples may be used for blank and recovery corrections.
- Reference samples chosen for performing a recovery correction shall be representative for the test samples, meaning that congener patterns shall not lead to an underestimation of levels.
- Extra reference samples at, e.g. 0,5× and 2× the maximum or action level may be included to demonstrate the proper performance of the test in the range of interest for the control of the maximum or action level. Combined, these samples may be used for calculating the BEQ-levels in test samples (see point 7.1.2.2).

7.3. Determination of cut-off values

The relationship between bioanalytical results in BEQ and results from confirmatory methods in TEQ shall be established (e.g. by matrix-matched calibration experiments, involving reference samples spiked at 0, 0,5×, 1× and 2× the maximum level (ML), with six repetitions on each level (n = 24)). Correction factors (blank and recovery) may be estimated from this relationship but shall be checked in each test series by including procedure/matrix blanks and recovery samples (see point 7.2).

Cut-off values shall be established for decision over sample compliance with maximum levels or for control of action levels, if of interest, with the respective maximum or action levels set for either PCDD/Fs and dioxin-like PCBs alone, or for the sum of PCDD/Fs and dioxin-like PCBs. They are represented by the lower endpoint of the distribution of bioanalytical results (corrected for blank and recovery) corresponding to the decision limit of the confirmatory method based on a 95 % level of confidence, implying a false-compliant rate < 5 %, and on a $RSD_R < 25$ %. The decision limit of the confirmatory method is the maximum level, taking into account the expanded measurement uncertainty.

In practice, the cut-off value (in BEQ) may be calculated from the following approaches (see Figure 1):

7.3.1. Use of the lower band of the 95 % prediction interval at the decision limit of the confirmatory method

$$\text{Cut-off value} = \text{BEQ}_{\text{DL}} - s_{y,x} \times t_{\alpha, f = m - 2} \sqrt{1/n + 1/m + (x_i - \bar{x})^2 / Q_{xx}}$$

with:

BEQ_{DL}	BEQ corresponding to the decision limit of the confirmatory method, being the ML taking into account the expanded measurement uncertainty
$s_{y,x}$	residual standard deviation
$t_{\alpha, f = m - 2}$	student factor ($\alpha = 5$ %, $f =$ degrees of freedom, single-sided)
m	total number of calibration points (index j)
n	number of repetitions on each level

x_i sample concentration (in TEQ) of calibration point i determined by a confirmatory method

\bar{x} mean of the concentrations (in TEQ) of all calibration samples

$$Q_{xx} = \sum_{j=1}^m (x_j - \bar{x})^2 \text{ square sum parameter}$$

i = index for calibration point i

7.3.2. Calculation from bioanalytical results (corrected for blank and recovery) of multiple analyses of samples ($n \geq 6$) contaminated at the decision limit of the confirmatory method, as the lower endpoint of the data distribution at the corresponding mean BEQ value:

$$\text{Cut-off value} = \text{BEQ}_{\text{DL}} - 1,64 \times \text{SD}_R$$

with

SD_R standard deviation of bioassay results at BEQ_{DL} , measured under within-laboratory reproducibility conditions

7.3.3. Calculation as mean value of bioanalytical results (in BEQ, corrected for blank and recovery) from multiple analysis of samples ($n \geq 6$) contaminated at two-thirds of the maximum or action level. This is based on the observation that this level will be around the cut-off determined under point 7.3.1 or 7.3.2.

Calculation of cut-off values based on a 95 % level of confidence implying a false-compliant rate $< 5 \%$, and a $\text{RSD}_R < 25 \%$:

1. from the lower band of the 95 % prediction interval at the decision limit of the confirmatory method,
2. from multiple analysis of samples ($n \geq 6$) contaminated at the decision limit of the confirmatory method as the lower endpoint of the data distribution (represented in the figure by a bell-shaped curve) at the corresponding mean BEQ value.

Figure 1

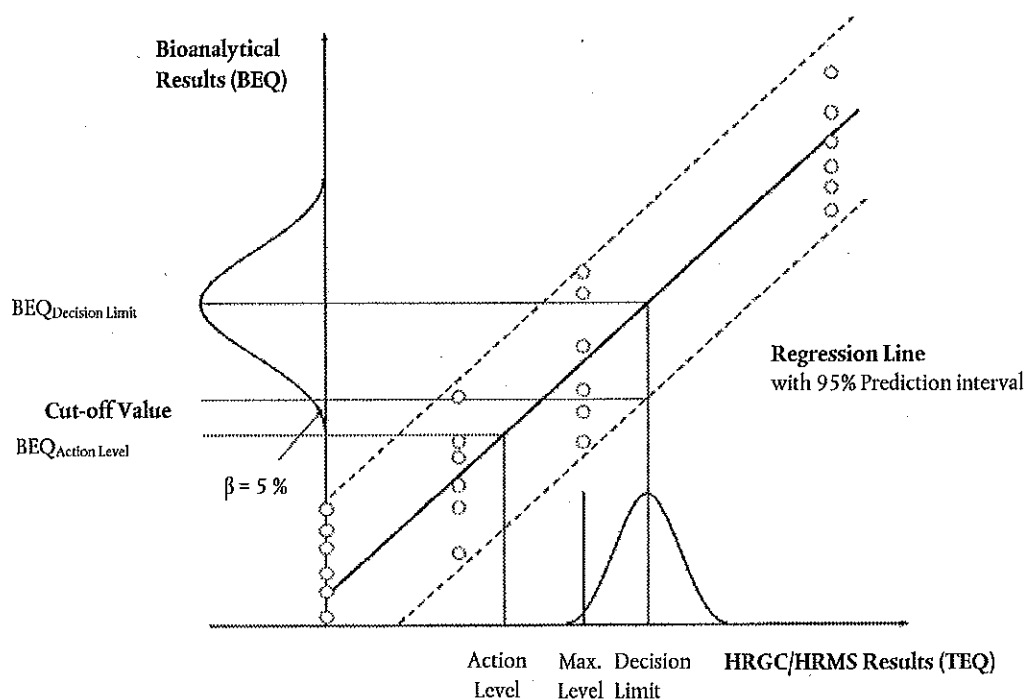

7.3.4. Restrictions to cut-off values

BEQ-based cut-off values calculated from the RSD_r achieved during validation using a limited number of samples with different matrix/congener patterns may be higher than the TEQ-based maximum or action levels due to a better precision than attainable in routine when an unknown spectrum of possible congener patterns has to be controlled. In such cases, cut-off values shall be calculated from an $RSD_r = 25\%$, or two-thirds of the maximum or action level shall be preferred.

7.4. Performance characteristics

- Since no internal standards can be used in bioanalytical methods, tests on repeatability shall be carried out to obtain information on the standard deviation within and between test series. Repeatability shall be below 20 % and intra-laboratory reproducibility shall be below 25 %. This shall be based on the calculated levels in BEQs after blank and recovery correction.
- As part of the validation process, the test must be shown to discriminate between a blank sample and a level at the cut-off value, allowing the identification of samples above the corresponding cut-off value (see point 7.1.2).
- Target compounds, possible interferences and maximum tolerable blank levels shall be defined.
- The per cent standard deviation in the response or concentration calculated from the response (only possible in working range) of a triplicate determination of a sample extract shall not be above 15 %.
- The uncorrected results of the reference sample(s) expressed in BEQs (blank and at the maximum or action level) shall be used for evaluation of the performance of the bioanalytical method over a constant time period.
- QCcharts for procedure blanks and each type of reference sample shall be recorded and checked to make sure the analytical performance is in accordance with the requirements, in particular for the procedure blanks with regard to the requested minimum difference to the lower end of the working range and for the reference samples with regard to within-laboratory reproducibility. Procedure blanks must be well controlled in order to avoid false-compliant results when subtracted.
- The results from the confirmatory methods of suspected samples and 2 to 10 % of the compliant samples (minimum of 20 samples per matrix) shall be collected and used to evaluate the performance of the screening method and the relationship between BEQs and TEQs. This database might be used for re-evaluation of cut-off values applicable to routine samples for the validated matrices.
- Successful method performance may also be demonstrated by participation in ring trials. The results from samples analysed in ring trials, covering a concentration range up to, e.g. $2 \times ML$, may also be included in the evaluation of the false-compliant rate, if a laboratory is able to demonstrate its successful performance. The samples shall cover most frequent congener patterns, representing various sources.
- During incidents, the cut-off values may be re-evaluated, reflecting the specific matrix and congener patterns of this single incident.

8. REPORTING OF THE RESULT

Confirmatory methods

- The analytical results shall contain the levels of the individual PCDD/F and dioxin-like PCB congeners and TEQ-values shall be reported as lower-bound, upper-bound and medium-bound in order to include a maximum of information in the reporting of the results and thereby enabling the interpretation of the results according to specific requirements.
- The report shall also include the method used for extraction of PCDD/Fs, dioxin-like PCBs and lipids. The lipid content of the sample shall be determined and reported for food matrices with maximum levels expressed on fat basis and with an expected fat concentration in the range of 0-2 % (in correspondence to existing legislation). For other samples, the determination of the lipid content is optional.

- The recoveries of the individual internal standards must be made available in case the recoveries are outside the range mentioned in point 6.2 where the maximum level is exceeded (in this case, the recoveries for one of the two duplicate analysis) and in other cases upon request.
- As the expanded measurement uncertainty is to be taken into account when deciding about the compliance of a sample, this parameter shall also be made available. Thus, analytical results shall be reported as $x \pm U$ whereby x is the analytical result and U is the expanded measurement uncertainty using a coverage factor of 2 which gives a level of confidence of approximately 95 %. In case of a separate determination of PCDD/Fs and dioxin-like-PCBs the sum of the estimated expanded uncertainty of the separate analytical results of PCDD/Fs and dioxin-like PCBs has to be used for the sum of PCDD/Fs and dioxin-like PCBs.
- The results shall be expressed in the same units and with the same number of significant figures as the maximum levels laid down in Regulation (EC) No 1881/2006.

Bioanalytical screening methods

- The result of the screening shall be expressed as compliant or suspected to be non-compliant ('suspected').
- In addition, an indicative result for PCDD/F and/or dioxin-like PCBs expressed in BEQ (not TEQ) may be given (see point 1). Samples with a response below the reporting limit shall be expressed as lower than the reporting limit. Samples with a response above the working range shall be reported as exceeding the working range and the level corresponding to the upper end of the working range shall be given in BEQ.
- For each type of sample matrix, the report shall mention the maximum or action level on which the evaluation is based.
- The report shall mention the type of test applied, the basic test principle and kind of calibration.
- The report shall also include the method used for extraction of PCDD/Fs, dioxin-like PCBs and lipids. The lipid content of the sample shall be determined and reported for food matrices with maximum levels expressed on fat basis and with an expected fat concentration in the range of 0-2 % (in correspondence to existing legislation). For other samples, the determination of the lipid content is optional.
- In the case of samples suspected to be non-compliant, the report needs to include a note on the action to be taken. The concentration of PCDD/Fs and the sum of PCDD/Fs and dioxin-like PCBs in those samples with elevated levels has to be determined/confirmed by a confirmatory method.
- Non-compliant results shall only be reported from confirmatory analysis.

Physico-chemical screening methods

- The result of the screening shall be expressed as compliant or suspected to be non-compliant ('suspected').
- For each type of sample matrix, the report shall mention the maximum or action level on which the evaluation is based.
- In addition, levels for individual PCDD/F and/or dioxin-like PCB congeners and TEQ-values reported as lower-bound, upper-bound and medium-bound may be given. The results shall be expressed in the same units and with (at least) the same number of significant figures as the maximum levels laid down in Regulation (EC) No 1881/2006.
- The recoveries of the individual internal standards must be made available in case the recoveries are outside the range mentioned in point 6.2 and in other cases upon request.
- The report shall mention the GC-MS method applied.
- The report shall also include the method used for extraction of PCDD/Fs, dioxin-like PCBs and lipids. The lipid content of the sample shall be determined and reported for food matrices with maximum levels expressed on fat basis and with an expected fat concentration in the range of 0-2 % (in correspondence to existing legislation). For other samples, the determination of the lipid content is optional.

-
- In case of samples suspected to be non-compliant, the report needs to include a note on the action to be taken. The concentration of PCDD/Fs and the sum of PCDD/Fs and dioxin-like PCBs in those samples with elevated levels has to be determined/confirmed by a confirmatory method.
 - Non-compliance can only be decided after confirmatory analysis.

Appendix

WHO-TEFs for human risk assessment based on the conclusions of the World Health Organisation (WHO) 0151 International Programme on Chemical Safety (IPCS) expert meeting which was held in Geneva in June 2005 ⁽¹⁾

Congener	TEF value	Congener	TEF value
Dibenzo-p-dioxins ('PCDDs')		'Dioxin-like' PCBs	
		Non-ortho PCBs + Mono-ortho PCBs	
2,3,7,8-TCDD	1		
1,2,3,7,8-PeCDD	1	Non-ortho PCBs	
1,2,3,4,7,8-HxCDD	0,1	PCB 77	0,0001
1,2,3,6,7,8-HxCDD	0,1	PCB 81	0,0003
1,2,3,7,8,9-HxCDD	0,1	PCB 126	0,1
1,2,3,4,6,7,8-HpCDD	0,01	PCB 169	0,03
OCDD	0,0003		
Dibenzofurans ('PCDFs')		Mono-ortho PCBs	
2,3,7,8-TCDF	0,1	PCB 105	0,00003
1,2,3,7,8-PeCDF	0,03	PCB 114	0,00003
2,3,4,7,8-PeCDF	0,3	PCB 118	0,00003
1,2,3,4,7,8-HxCDF	0,1	PCB 123	0,00003
1,2,3,6,7,8-HxCDF	0,1	PCB 156	0,00003
1,2,3,7,8,9-HxCDF	0,1	PCB 157	0,00003
2,3,4,6,7,8-HxCDF	0,1	PCB 167	0,00003
1,2,3,4,6,7,8-HpCDF	0,01	PCB 189	0,00003
1,2,3,4,7,8,9-HpCDF	0,01		
OCDF	0,0003		

Abbreviations used: 'T' = tetra; 'Pe' = penta; 'Hx' = hexa; 'Hp' = hepta; 'O' = octa; 'CDD' = chlorodibenzodioxin; 'CDF' = chlorodibenzofuran; 'CB' = chlorobiphenyl.

⁽¹⁾ Martin van den Berg et al., The 2005 World Health Organisation Re-evaluation of Human and Mammalian Toxic Equivalency Factors for Dioxins and Dioxin-like Compounds. Toxicological Sciences 93(2), 223-241 (2006).

ANNEX IV

SAMPLE PREPARATION AND REQUIREMENTS FOR METHODS OF ANALYSIS USED IN CONTROL OF THE LEVELS OF NON-DIOXIN-LIKE PCBs IN CERTAIN FOODSTUFFS

The requirements set out in this Annex shall be applied where foodstuffs are analysed for the official control of the levels of non-dioxin-like PCBs and as regards sample preparation and analytical requirements for other regulatory purposes, including the controls performed by the food business operator to ensure compliance with the provisions in Article 4 of Regulation (EC) No 852/2004.

The provisions on sample preparation provided for in point 3 of Annex III of this Regulation shall also be applicable for the control of the levels of non-dioxin-like PCBs in food.

1. Applicable detection methods

Gas Chromatography/Electron Capture Detection (GC-ECD), GC-LRMS, GC-MS/MS, GC-HRMS or equivalent methods.

2. Identification and confirmation of analytes of interest:

- Relative retention time in relation to internal standards or reference standards (acceptable deviation of $\pm 0,25$ %).
- Gas chromatographic separation of the non-dioxin-like PCBs (from interfering substances, especially co-eluting PCBs, in particular if levels of samples are in the range of legal limits and non-compliance is to be confirmed ⁽¹⁾).
- For GC-MS techniques:
 - Monitoring of at least the following number of molecular ions or characteristic ions from the molecular cluster:
 - two specific ions for HRMS,
 - three specific ions for LRMS,
 - two specific precursor ions, each with one specific corresponding transition product ion for MS-MS.
 - Maximum permitted tolerances for abundance ratios for selected mass fragments:
Relative deviation of abundance ratio of selected mass fragments from theoretical abundance or calibration standard for target ion (most abundant ion monitored) and qualifier ion(s): ± 15 %.
- For GC-ECD:
Confirmation of results exceeding the maximum level with two GC columns with stationary phases of different polarity.

3. Demonstration of performance of method:

Validation in the range of the maximum level (0,5 to 2 times the maximum level) with an acceptable coefficient of variation for repeated analysis (see requirements for intermediate precision in point 8).

4. Limit of quantification:

The sum of the LOQs ⁽²⁾ of non-dioxin-like PCBs shall not be higher than one-third of the maximum level ⁽³⁾.

5. Quality control:

Regular blank controls, analysis of spiked samples, quality control samples, participation in interlaboratory studies on relevant matrices.

⁽¹⁾ Congeners often found to co-elute are, e.g. PCB 28/31, PCB 52/69 and PCB 138/163/164. For GC-MS also possible interferences from fragments of higher chlorinated congeners have to be considered.

⁽²⁾ The principles as described in the 'Guidance Document on the Estimation of LOD and LOQ for Measurements in the Field of Contaminants in Feed and Food' [link to website] shall be followed when applicable.

⁽³⁾ It is highly recommendable to have a lower contribution of the reagent blank level to the level of a contaminant in a sample. It is in the responsibility of the laboratory to control the variation of blank levels, in particular, if the blank levels are subtracted.

6. Control of recoveries:

- Use of suitable internal standards with physico-chemical properties comparable to analytes of interest.
- Addition of internal standards:
 - Addition to products (before extraction and clean-up process),
 - Addition also possible to extracted fat (before clean-up process), if maximum level is expressed on fat basis.
- Requirements for methods using all six isotope-labelled non-dioxin-like PCB congeners:
 - Correction of results for recoveries of internal standards,
 - Generally acceptable recoveries of isotope-labelled internal standards are between 60 and 120 %,
 - Lower or higher recoveries for individual congeners with a contribution to the sum of non-dioxin-like PCBs below 10 % are acceptable.
- Requirements for methods using not all six isotope-labelled internal standards or other internal standards:
 - Control of recovery of internal standard(s) for every sample,
 - Acceptable recoveries of internal standard(s) between 60 and 120 %,
 - Correction of results for recoveries of internal standards.
- The recoveries of unlabelled congeners shall be checked by spiked samples or quality control samples with concentrations in the range of the maximum level. Acceptable recoveries for these congeners are between 60 and 120 %.

7. Requirements for laboratories

In accordance with the provisions of Regulation (EC) No 882/2004, laboratories shall be accredited by a recognised body operating in accordance with ISO Guide 58 to ensure that they are applying analytical quality assurance. Laboratories shall be accredited following the EN ISO/IEC 17025 standard. In addition, the principles as described in Technical Guidelines for the estimation of measurement uncertainty and limits of quantification for PCB analysis shall be followed when applicable ⁽¹⁾.

8. Performance characteristics: Criteria for the sum of non-dioxin-like PCBs at the maximum level

	Isotope dilution mass spectrometry ^(*)	Other techniques
Trueness	- 20 to + 20 %	- 30 to + 30 %
Intermediate precision (RSD _R)	≤ 15 %	≤ 20 %
Difference between upper and lower bound calculation	≤ 20 %	≤ 20 %

^(*) Use of all six ¹³C-labelled analogues as internal standards required

9. Reporting of results

- The analytical results shall contain the levels of the individual non-dioxin-like PCB congeners and the sum of non-dioxin-like PCBs, reported as lower-bound, upper-bound and medium-bound, in order to include a maximum of information in the reporting of the results and thereby enabling the interpretation of the results according to specific requirements.

⁽¹⁾ 'Guidance Document on Measurement Uncertainty for Laboratories performing PCDD/F and PCB Analysis using Isotope Dilution Mass Spectrometry' [link to website], 'Guidance Document on the Estimation of LOD and LOQ for Measurements in the Field of Contaminants in Feed and Food' [link to website].

-
- The report shall also include the method used for the extraction of PCBs and lipids. The lipid content of the sample shall be determined and reported for food matrices with maximum levels expressed on fat basis and with an expected fat concentration in the range of 0-2 % (in correspondence to existing legislation). For other samples, the determination of the lipid content is optional.
 - The recoveries of the individual internal standards must be made available in case the recoveries are outside the range mentioned in point 6, in case the maximum level is exceeded and in other cases upon request.
 - As the expanded measurement uncertainty is to be taken into account when deciding about the compliance of a sample, that parameter shall also be made available. Thus, analytical results shall be reported as $x \pm U$ whereby x is the analytical result and U is the expanded measurement uncertainty using a coverage factor of 2 which gives a level of confidence of approximately 95 %.
 - The results shall be expressed in the same units and with the same number of significant figures as the maximum levels laid down in Regulation (EC) No 1881/2006.

Annex V:

Official Journal of the European Union

**COMMISSION REGULATION (EU) No 1259/2011
of 2 December 2011**

**amending Regulation (EC) No 1881/2006 as regards maximum levels for dioxins, dioxin-like
PCBs and non dioxin-like PCBs in foodstuffs**

COMMISSION REGULATION (EU) No 1259/2011

of 2 December 2011

amending Regulation (EC) No 1881/2006 as regards maximum levels for dioxins, dioxin-like PCBs and non dioxin-like PCBs in foodstuffs

(Text with EEA relevance)

THE EUROPEAN COMMISSION,

Having regard to the Treaty on the Functioning of the European Union,

Having regard to Council Regulation (EEC) No 315/93 of 8 February 1993 laying down Community procedures for contaminants in food ⁽¹⁾, and in particular Article 2(3) thereof,

Whereas:

- (1) Commission Regulation (EC) No 1881/2006 of 19 December 2006 setting maximum levels for certain contaminants in foodstuffs ⁽²⁾ sets maximum levels for dioxins and dioxin-like PCBs in a range of foodstuffs.
- (2) Dioxins belong to a group of 75 polychlorinated dibenzo-p-dioxin (PCDD) congeners and 135 polychlorinated dibenzofuran (PCDF) congeners, of which 17 are of toxicological concern. Polychlorinated biphenyls (PCBs) are a group of 209 different congeners which can be divided into two groups according to their toxicological properties: 12 congeners exhibit toxicological properties similar to dioxins and are therefore often referred to as 'dioxin-like PCBs' (DL-PCB). The other PCBs do not exhibit dioxin-like toxicity but have a different toxicological profile and are referred to as 'non dioxin-like PCB' (NDL-PCB).
- (3) Each congener of dioxins or DL-PCBs exhibits a different level of toxicity. In order to be able to sum up the toxicity of these different congeners, the concept of toxic equivalency factors (TEFs) was introduced to facilitate risk assessment and regulatory control. As a result the analytical results relating to all the individual dioxin and dioxin-like PCB congeners of toxicological concern are expressed in terms of a quantifiable unit, namely the TCDD toxic equivalent (TEQ).
- (4) The World Health Organisation (WHO) held an expert workshop on 28 to 30 June 2005 concerning the TEF values, agreed by WHO in 1998. A number of TEF values were changed, notably for PCBs, octachlorinated congeners and pentachlorinated furans. The data on the effect of the new TEF values and the recent occurrence are compiled in the European Food Safety Authority's

(EFSA) scientific report 'Results of the monitoring of dioxin levels in food and feed' ⁽³⁾. Therefore, it is appropriate to review the maximum levels of PCBs taking into account these new data.

- (5) The Scientific Panel on Contaminants in the Food Chain of the EFSA on a request from the Commission has adopted an opinion on the presence of NDL-PCBs in feed and food ⁽⁴⁾.
- (6) The sum of the six marker or indicator PCBs (PCB 28, 52, 101, 138, 153 and 180) comprises about half of the amount of total NDL-PCB present in feed and food. That sum is considered as an appropriate marker for occurrence and human exposure to NDL-PCB and therefore should be set as a maximum level.
- (7) Maximum levels have been established taking into account recent occurrence data compiled in the EFSA scientific report 'Results of the monitoring of non dioxin-like PCBs in food and feed' ⁽⁵⁾. Although it is possible to achieve lower limits of quantification (LOQ), it can be observed that a considerable number of laboratories apply an LOQ of 1 µg/kg fat or even 2 µg/kg fat. Expressing the analytical result as an upperbound level would result in some cases in a level close to the maximum level if very strict maximum levels would be established, even if no PCBs have been quantified. It was also acknowledged that for certain food categories the data were not very extensive. Therefore, it would be appropriate to review the maximum levels in 3 years time, based upon a more extensive database obtained with a method of analysis with sufficient sensitivity for quantifying low levels.
- (8) Derogations have been granted to Finland and Sweden to place on the market fish originating in the Baltic region and intended for consumption in their territory with dioxin levels higher than the maximum levels established for dioxins and the sum of dioxins and DL-PCBs in fish. Those Member States have fulfilled the conditions as regards the provision of information to consumers on dietary recommendations. Every year they communicate to the Commission the results of their monitoring of the levels of dioxins in fish from the Baltic region and the measures to reduce human exposure to dioxins from the Baltic region.

⁽¹⁾ OJ L 37, 13.2.1993, p. 1.

⁽²⁾ OJ L 364, 20.12.2006, p. 5.

⁽³⁾ EFSA Journal 2010; 8(3):1385, <http://www.efsa.europa.eu/en/efsajournal/doc/1385.pdf>

⁽⁴⁾ EFSA Journal (2005) 284, p. 1, <http://www.efsa.europa.eu/en/efsajournal/doc/284.pdf>

⁽⁵⁾ EFSA Journal 2010; 8(7):1701, <http://www.efsa.europa.eu/en/efsajournal/doc/1701.pdf>

- (9) On the basis of the results of monitoring of levels of dioxins and DL-PCBs carried out by Finland and Sweden, the derogation granted could be limited to certain fish species. Given the persistent presence of dioxins and PCBs in the environment and consequently in fish it is appropriate to grant this derogation without a time limit.
- (10) As regards wild caught salmon, Latvia has requested a similar derogation as that granted to Finland and Sweden. To that end, Latvia has demonstrated that human exposure to dioxins and DL-PCBs in its territory is not higher than the highest average level in any of the Member States and that it has a system in place to ensure that consumers are fully informed of dietary recommendations with regard to restrictions on the consumption of fish from the Baltic region by identified vulnerable sections of the population in order to avoid potential health risks. Furthermore, monitoring of the levels of dioxins and DL-PCBs in fish from the Baltic region should be carried out and the results and measures that have been taken to reduce human exposure to dioxins and DL-PCBs from fish from the Baltic region should be reported to the Commission. The necessary measures have been put in place ensuring that fish and fish products not complying with EU maximum levels for PCBs are not marketed in other Member States.
- (11) Given that the contamination pattern of NDL-PCBs in fish from the Baltic region show similarities with the contamination of dioxins and DL-PCBs and given that also NDL-PCBs are very persistent in the environment, it is appropriate to grant a similar derogation as regards the presence of NDL-PCBs as for dioxins and DL-PCBs in fish from the Baltic region.
- (12) EFSA has been requested to provide scientific opinion as regards the presence of dioxins and dioxin-like PCBs in sheep and deer liver and the appropriateness to establish maximum levels for dioxins and PCBs in liver and derived products on product basis rather than on a fat basis, as is currently the case. Therefore, the provisions on liver and derived products should be reviewed in particular the provisions as regards sheep and deer liver once the EFSA opinion is available. In the meantime it is appropriate to set the maximum level for dioxins and PCBs on a fat basis.
- (13) Foods with less than 1 % fat were until now excluded from the maximum level for dioxins and DL-PCBs, given that those foods are generally minor contributors to the human exposure. However, there have been cases with food containing less than 1 % fat but with very high levels of dioxins and DL-PCBs in the fat. Therefore, it is appropriate to apply the maximum level to such foods, but on a product basis. Taking into account that a maximum level is established on product basis for certain low fat containing foods, it is appropriate to apply a maximum level on product basis for foods containing less than 2 % fat.
- (14) In the light of the monitoring data for dioxins and DL-PCBs in foods for infants and young children it is appropriate to set specific lower maximum levels for dioxins and DL-PCBs in foods for infants and young children. The Federal Institute for Risk Assessment from Germany has addressed to EFSA a specific request to assess the risk for infants and young children of the presence of dioxins and dioxin-like PCBs in foods for infants and young children. Therefore, the provisions on foods for infants and young children should be reviewed once the EFSA opinion is available.
- (15) The measures provided for in this Regulation are in accordance with the opinion of the Standing Committee on the Food Chain and Animal Health and neither the European Parliament nor the Council have opposed them,

HAS ADOPTED THIS REGULATION:

Article 1

Regulation (EC) No 1881/2006 is amended as follows:

(1) Article 7 is amended as follows:

- (a) The title '**Temporary derogations**' is replaced by '**Derogations**';
- (b) paragraph 4 is replaced by the following:

'4. By way of derogation from Article 1, Finland, Sweden and Latvia may authorise the placing on their market of wild caught salmon (*Salmo salar*) and products thereof originating in the Baltic region and intended for consumption in their territory with levels of dioxins and/or dioxin-like PCBs and/or non-dioxin-like PCBs higher than those set out in point 5.3 of the Annex, provided that a system is in place to ensure that consumers are fully informed of the dietary recommendations with regard to the restrictions on the consumption of wild caught salmon from the Baltic region and products thereof by identified vulnerable sections of the population in order to avoid potential health risks.

Finland, Sweden and Latvia shall continue to apply the necessary measures to ensure that wild caught salmon and products thereof not complying with point 5.3 of the Annex are not marketed in other Member States.

Finland, Sweden and Latvia will report yearly to the Commission the measures they have taken to effectively inform the identified vulnerable sections of the population of the dietary recommendations and to ensure that wild caught salmon and products thereof not compliant with the maximum levels is not marketed in other Member States. They shall furthermore provide evidence of the effectiveness of these measures.;

(c) the following paragraph 5 is added:

‘5. By way of derogation from Article 1, Finland and Sweden may authorise the placing on their market of wild caught herring larger than 17 cm (*Clupea harengus*), wild caught char (*Salvelinus* spp.), wild caught river lamprey (*Lampetra fluviatilis*) and wild caught trout (*Salmo trutta*) and products thereof originating in the Baltic region and intended for consumption in their territory with levels of dioxins and/or dioxin-like PCBs and/or non dioxin-like PCBs higher than those set out in point 5.3 of the Annex, provided that a system is in place to ensure that consumers are fully informed of the dietary recommendations with regard to the restrictions on the consumption of wild caught herring larger than 17 cm, wild caught char, wild caught river lamprey and wild caught trout from the Baltic region and products thereof by identified vulnerable sections of the population in order to avoid potential health risks.

Finland and Sweden shall continue to apply the necessary measures to ensure that wild caught herring larger than 17 cm, wild caught char, wild caught river

lamprey and wild caught trout and products thereof not complying with point 5.3 of the Annex are not marketed in other Member States.

Finland and Sweden will report yearly to the Commission the measures they have taken to effectively inform the identified vulnerable sections of the population of the dietary recommendations and to ensure that fish and products thereof not compliant with the maximum levels is not marketed in other Member States. They shall furthermore provide evidence of the effectiveness of these measures.’;

(2) the Annex is amended in accordance with the Annex to this Regulation.

Article 2

This Regulation shall enter into force on the 20th day following its publication in the *Official Journal of the European Union*.

It shall apply from 1 January 2012.

This Regulation shall be binding in its entirety and directly applicable in all Member States.

Done at Brussels, 2 December 2011.

For the Commission

The President

José Manuel BARROSO

ANNEX

Section 5: Dioxins and PCBs of the Annex to Regulation (EC) No 1881/2006 is amended as follows:

(a) Section 5: Dioxins and PCBs is replaced by the following:

'Section 5: Dioxins and PCBs ⁽³¹⁾

Foodstuffs		Maximum levels		
		Sum of dioxins (WHO-PCDD/F-TEQ) ⁽³²⁾	Sum of dioxins and dioxin-like PCBs (WHO-PCDD/F-PCB-TEQ) ⁽³²⁾	Sum of PCB28, PCB52, PCB101, PCB138, PCB153 and PCB180 (ICES - 6) ⁽³²⁾
5.1	Meat and meat products (excluding edible offal) of the following animals ⁽⁶⁾ :			
	— bovine animals and sheep	2,5 pg/g fat ⁽³³⁾	4,0 pg/g fat ⁽³³⁾	40 ng/g fat ⁽³³⁾
	— poultry	1,75 pg/g fat ⁽³³⁾	3,0 pg/g fat ⁽³³⁾	40 ng/g fat ⁽³³⁾
	— pigs	1,0 pg/g fat ⁽³³⁾	1,25 pg/g fat ⁽³³⁾	40 ng/g fat ⁽³³⁾
5.2	Liver of terrestrial animals referred to in 5.1 ⁽⁶⁾ , and derived products thereof,	4,5 pg/g fat ⁽³³⁾	10,0 pg/g fat ⁽³³⁾	40 ng/g fat ⁽³³⁾
5.3	Muscle meat of fish and fishery products and products thereof ⁽²⁵⁾ ⁽³⁴⁾ , with the exemption of: <ul style="list-style-type: none"> — wild caught eel — wild caught fresh water fish, with the exception of diadromous fish species caught in fresh water — fish liver and derived products — marine oils <p>The maximum level for crustaceans applies to muscle meat from appendages and abdomen ⁽⁴⁴⁾. In case of crabs and crab-like crustaceans (<i>Brachyura</i> and <i>Anomura</i>) it applies to muscle meat from appendages.</p>	3,5 pg/g wet weight	6,5 pg/g wet weight	75 ng/g wet weight
5.4	Muscle meat of wild caught fresh water fish, with the exception of diadromous fish species caught in fresh water, and products thereof ⁽²⁵⁾	3,5 pg/g wet weight	6,5 pg/g wet weight	125 ng/g wet weight
5.5	Muscle meat of wild caught eel (<i>Anguilla anguilla</i>) and products thereof	3,5 pg/g wet weight	10,0 pg/g wet weight	300 ng/g wet weight
5.6	Fish liver and derived products thereof with the exception of marine oils referred to in point 5.7	—	20,0 pg/g wet weight ⁽³⁸⁾	200 ng/g wet weight ⁽³⁸⁾
5.7	Marine oils (fish body oil, fish liver oil and oils of other marine organisms intended for human consumption)	1,75 pg/g fat	6,0 pg/g fat	200 ng/g fat
5.8	Raw milk ⁽⁶⁾ and dairy products ⁽⁶⁾ , including butter fat	2,5 pg/g fat ⁽³³⁾	5,5 pg/g fat ⁽³³⁾	40 ng/g fat ⁽³³⁾

Foodstuffs		Maximum levels		
		Sum of dioxins (WHO-PCDD/F-TEQ) ⁽³²⁾	Sum of dioxins and dioxin-like PCBs (WHO-PCDD/F-PCB-TEQ) ⁽³²⁾	Sum of PCB28, PCB52, PCB101, PCB138, PCB153 and PCB180 (ICES – 6) ⁽³²⁾
5.9	Hen eggs and egg products ⁽⁶⁾	2,5 pg/g fat ⁽³³⁾	5,0 pg/g fat ⁽³³⁾	40 ng/g fat ⁽³³⁾
5.10	Fat of the following animals:			
	— bovine animals and sheep	2,5 pg/g fat	4,0 pg/g fat	40 ng/g fat
	— poultry	1,75 pg/g fat	3,0 pg/g fat	40 ng/g fat
	— pigs	1,0 pg/g fat	1,25 pg/g fat	40 ng/g fat
5.11	Mixed animal fats	1,5 pg/g fat	2,50 pg/g fat	40 ng/g fat
5.12	Vegetable oils and fats	0,75 pg/g fat	1,25 pg/g fat	40 ng/g fat
5.13	Foods for infants and young children ⁽⁴⁾	0,1 pg/g wet weight	0,2 pg/g wet weight	1,0 ng/g wet weight'

(b) footnote 31 is replaced by the following:

⁽³¹⁾ Dioxins (sum of polychlorinated dibenzo-para-dioxins (PCDDs) and polychlorinated dibenzofurans (PCDFs), expressed as World Health Organisation (WHO) toxic equivalent using the WHO-toxic equivalency factors (WHO-TEFs)) and sum of dioxins and dioxin-like PCBs (sum of PCDDs, PCDFs and polychlorinated biphenyls (PCBs), expressed as WHO toxic equivalent using the WHO-TEFs). WHO-TEFs for human risk assessment based on the conclusions of the World Health Organization (WHO) – International Programme on Chemical Safety (IPCS) expert meeting which was held in Geneva in June 2005 (Martin van den Berg et al., The 2005 World Health Organization Re-evaluation of Human and Mammalian Toxic Equivalency Factors for Dioxins and Dioxin-like Compounds. Toxicological Sciences 93(2), 223–241 (2006))

Congener	TEF value	Congener	TEF value
Dibenzo-p-dioxins ('PCDDs')		"Dioxin-like" PCBs Non-ortho PCBs + Mono-ortho PCBs	
2,3,7,8-TCDD	1		
1,2,3,7,8-PeCDD	1	<i>Non-ortho PCBs</i>	
1,2,3,4,7,8-HxCDD	0,1	PCB 77	0,0001
1,2,3,6,7,8-HxCDD	0,1	PCB 81	0,0003
1,2,3,7,8,9-HxCDD	0,1	PCB 126	0,1
1,2,3,4,6,7,8-HpCDD	0,01	PCB 169	0,03
OCDD	0,0003		
Dibenzofurans ('PCDFs')		<i>Mono-ortho PCBs</i>	
2,3,7,8-TCDF	0,1	PCB 105	0,00003
1,2,3,7,8-PeCDF	0,03	PCB 114	0,00003
2,3,4,7,8-PeCDF	0,3	PCB 118	0,00003
1,2,3,4,7,8-HxCDF	0,1	PCB 123	0,00003
1,2,3,6,7,8-HxCDF	0,1	PCB 156	0,00003
1,2,3,7,8,9-HxCDF	0,1	PCB 157	0,00003
2,3,4,6,7,8-HxCDF	0,1	PCB 167	0,00003
1,2,3,4,6,7,8-HpCDF	0,01	PCB 189	0,00003
1,2,3,4,7,8,9-HpCDF	0,01		
OCDF	0,0003		

Abbreviations used: "T" = tetra; "Pe" = penta; "Hx" = hexa; "Hp" = hepta; "O" = octa; "CDD" = chlorodibenzodioxin; "CDF" = chlorodibenzofuran; "CB" = chlorobiphenyl.

(c) footnote 33 is replaced by the following:

(³³) The maximum level expressed on fat is not applicable for foods containing < 2 % fat. For foods containing less than 2 % fat, the maximum level applicable is the level on product basis corresponding to the level on product basis for the food containing 2 % fat, calculated from the maximum level established on fat basis, making use of following formula:

Maximum level expressed on product basis for foods containing less than 2 % fat = maximum level expressed on fat for that food x 0,02'.

Annex VI:

**Recommended Method on
MICROWAVE DIGESTION OF MARINE SAMPLES
FOR THE DETERMINATION
OF TRACE ELEMENT CONTENT**



REPORT

Recommended Method on MICROWAVE DIGESTION OF MARINE SAMPLES FOR THE DETERMINATION OF TRACE ELEMENT CONTENT

IAEA/NAEL

**Marine Environmental Studies Laboratory in co-operation with
UNEP/MAP MED POL**

November 2011

For further information on this method, please contact:

IAEA-Environment Laboratories
Marine Environmental Studies Laboratory
4a Quai Antoine 1er
MC-98000 Principality of Monaco

Tel. (377) 979 772 72 Fax. (377) 979 772 73

E-mail: NAEL-MESL.Contact-Point@iaea.org

Recommended Method on
MICROWAVE DIGESTION OF MARINE SAMPLES
FOR THE DETERMINATION OF TRACE ELEMENT CONTENT

DISCLAIMER

This is not an official IAEA publication. The views expressed do not necessarily reflect those of the International Atomic Energy Agency or its Member States.

The material has not undergone an official review by the IAEA. This document should not be quoted or listed as a reference.

The use of particular designations of countries or territories does not imply any judgment by the IAEA, as to the legal status of such countries or territories, of their authorities and institutions or of the delimitation of their boundaries.

The mention of names of specific companies or products (whether or not indicated as registered) does not imply any intention to infringe proprietary rights, nor should it be construed as an endorsement or recommendation on the part of the IAEA.

Limited Distribution

Reproduced by the IAEA

TABLE OF CONTENTS

1. SCOPE	1
2. PRINCIPLE	1
3. SAMPLE PRE-TREATMENT	1
4. REAGENTS	1
5. MATERIAL	2
6. PROCEDURE	2
7. QUALITY CONTROL	5
8. REFERENCES	5

NOTE: This method is not intended to be an analytical training manual. Therefore, the method is written with the assumption that it will be performed by formally trained analytical chemist. Several stages of this procedure are potentially hazardous, especially stages with HF; users should be familiar with the necessary safety precautions.

In addition, the IAEA's recommended methods are intended to be guidance methods that can be used by laboratories as a starting point for generating their own standard operating procedure. If performance data are included in the method, they shall not be used as absolute QC acceptance criteria.

1. SCOPE

The method here below describes the protocol for dissolution of samples from marine origin. Digests are suitable for analyses of total content of trace element in sediment and biological material.

The goal of this method is the total sample decomposition with the judicious choice of acid combinations this is achievable for most matrices. The selection of reagents which give the highest recoveries for the target analytes is considered the optimum method condition.

The recommended protocol is mainly based on the EPA 3052 method; users are encouraged to consult this document (EPA, 1996).

2. PRINCIPLE

The grinded and dried samples are solubilized in an acid mixture using microwave oven apparatus.

The use of hydrofluoric acid allows the decomposition of silicates by reaction of F with Si to form the volatile SiF₄. The excess of hydrofluoric acid is either neutralized by boric acid, or digests are evaporated to dryness depending on the method used to analyze samples.

3. SAMPLE PRE-TREATMENT

Sediment samples are prepared following the recommendations of UNEP (2005).

Marine organisms are prepared following the recommendations of UNEP (1984, 1994).

4. REAGENTS

The reagents used shall meet the purity requirement of the subsequent analyses

- 4.1. ULTRAPUR WATER (type MilliQ).
- 4.2. NITRIC ACID 65%.
- 4.3. HYDROFLUORIC ACID.
- 4.4. HYDROCHLORIC ACID.
- 4.5. BORIC ACID.
- 4.6. HYDROGEN PEROXIDE.

5. MATERIAL

5.1. MICROWAVE APPARATUS

The microwave decomposition system should be temperature controlled. The temperature sensor should be accurate at $\pm 2.5^{\circ}\text{C}$. The calibration of the temperature sensor should be done at least once a year, preferably by the maintenance service of the manufacturer.

The microwave unit should be corrosion resistant.

The unit cavity should be well ventilated and connected to fume cleaner or special neutralizing system.

The method requires microwave transparent and acid resistant material (i.e. PFA, TFM) to be used as reactor. The minimal volume of the vessels should be 45 ml and it should be able to work under the pressure of 800PSI. the reactor system should be equipped with a pressure relief system.

- 5.2. ANALYTICAL BALANCE with 0.001 g precision at least.
- 5.3. FUME HOOD.
- 5.4. LAMINAR FLOW HOOD.
- 5.5. VOLUMETRIC CONTAINERS of 50 ml or 100 ml in polypropylene.
- 5.6. WEIGHING CUP in polyethylene.
- 5.7. PLASTIC SPATULAS.

6. PROCEDURE

- 6.1. All PLASTIC MATERIAL (i.e. volumetric, weighing cup...) should be acid cleaned by soaking in laboratory soap (or 10% alcohol) for at least 24h, followed by 24h of soaking in 10% nitric acid. Stronger acid cleaning protocol could be applied depending on the requirement of the subsequent analyses.
- 6.2. MICROWAVE VESSELS should be at least cleaned after each use by running the same microwave program used for samples with 5 ml of HNO_3 . If the risk of cross contamination is high (i.e. running sandy sediment after organic rich sediment) and/or in the case of long storage, the vessels should be cleaned twice. If available, an acid cleaner

(using acid vapors) can be used as a final cleaning stage. After cleaning, the vessels should be carefully rinsed with water and dried under a laminar flow hood. If a laminar flow hood is not available, vessels should be kept locked in double plastic bag; date of storage should be mentioned on the second bag.

6.3. Accurately weigh 0.1 to 0.5 g of well mixed sample in the microwave vessel.

6.4. In a fume hood, add 5 ml of nitric acid and 2 ml of hydrofluoric acid, close vessels with caps, then it is recommended to let samples react for at least 1 hour (or more if possible). Protect vessels by covering them with plastic bags or place them in a laminar flow hood compatible with acid fume. The quantity of hydrofluoric acid depends on the expected content of silicon dioxide, samples with low concentrations of silicon dioxide (< 10% like plant material to 0% like biological sample) may require less hydrofluoric acid (0.5 ml to 0 ml). Examples of acid quantities for different matrix are listed in table below.

	HF (ml)	HNO ₃ (ml)	HCl (ml)	H ₂ O ₂ (ml)	Boric (g)
Sediment	2	5	2 or 0	2	0.8
Fish	0	5	2 or 0	2	0
Sea plant	0.5	5	2 or 0	2	0

6.5. After room temperature pre-digestion, add 2 ml of hydrogen peroxide and close the reactors as recommended by the microwave manufacturer.

NOTE: The quantity and ratio of reagent can be adapted on a performance based judgment (i.e. visual total digestion, certified reference material results).

- In case of a sample containing high calcium carbonate, the hydrofluoric acid content can be set to 0 to avoid precipitation of insoluble CaF.
- A two stage digestion, using half of the hydrofluoric acid at the first stage and half at the second, could increase recovery and help achieving total decomposition.
- Additional reagent can be added depending on the sample composition to achieve complete dissolution. For example, 2±2 ml of HCl can be added to help the stabilization of As, Sb, Hg, Fe and Al at high level; however HCl might increase analytical difficulties for some techniques (i.e. ICP-MS) (Kingston 1997)
- Only one acid mixture or quantity should be used in a single batch, in the microwave, to insure consistent reaction conditions between all vessels and monitored conditions. This limitation is due to the current practice of monitoring a representative vessel, and applying a uniform microwave field to reproduce these reaction conditions within a group of vessels being simultaneously heated.

6.6. Place the closed reactor in the microwave apparatus, connect temperature and pressure control as specified by the manufacturer. The samples should be heated at 180°C

(minimum) in about 6 minutes and the temperature maintained for at least 10 minutes. The total decomposition is primarily controlled by maintaining samples at 180°C for 10 minutes. The ramping profile can be adapted, especially for safety purpose when very reactive samples are decomposed (i.e. biological material). In that case, it is recommended to increase the ramping time to 10 or 15 minutes. If possible, record temperature and pressure profile. In most samples matrices, pressure should peak between 5 and 15 minutes; profiles can be used to optimize temperature program.

- 6.7. At the end of the temperature profile, let the sample cool until the inside temperature goes down to 60°C, then remove the reactors from the microwave and place them in a ventilated fume hood. The pressure is carefully released following the manufacturer's instruction and reactors are opened.
- 6.8. In the case of removal of hydrofluoric acid excess with boric acid, 0.8 g of boric acid and 15 ml of water are added in the vessel. The quantity of boric acid is proportional to the quantity of hydrofluoric acid (usually 0.4 g for 1 ml should be sufficient). The vessels are closed again and run in the microwave with a program that heat samples at 170°C in 10 minutes and maintain this temperature for 10 minutes.
- 6.9. At the end of the temperature profile, let the sample cool until inside the temperature goes down to 60°C, then remove the reactors from the microwave and place them in a ventilated fume hood. The pressure is carefully released following the manufacturer's instruction and reactors are opened. Transfer the samples in a volumetric container and dilute them to a known volume (or a known weight, this requires to record the tare of each container before).

NOTE: An excess of boric acid will produce cloudy solutions, this might cause problem with sample introduction system of ICP. The use of boric acid will prevent measurement of boron, and possible bias introduced should be carefully investigated.

- If the use of boric acid is not possible, or if it is necessary to reduce the concentration of acid in final solutions, digest can be evaporated to incipient dryness on a hot plate at about 140°C. This stage should be performed in a controlled environment to avoid contamination and acid vapour should be treated. Some microwave oven apparatus can perform evaporation. The residue is then diluted to a known volume in nitric or hydrochloric diluted solution (usually 2% v/v) depending on the subsequent analytical method used.
- In case of insoluble precipitate or residue some extra steps can be performed like the addition of 2 ml of perchloric acid to the solution before evaporation, but this requires doing the evaporation under a specific hood for safety reason. Another option is the addition of 2 ml of concentrated hydrochloric acid, evaporation to near dryness, addition of concentrated nitric acid, evaporation to near dryness and dilution in known volume in 2% nitric acid solution.

Most samples will be totally dissolved by this method with the judicious choice of the acid combinations. A few refractory sample matrix compounds, such as TiO₂, alumina, and other oxides may not be totally dissolved, and in some cases may sequester target analyte elements.

7. QUALITY CONTROL

- 7.1. Each microwave batch should contain at the minimum one certified reference material of representative matrix.
- 7.2. A duplicate or triplicate sample should be processed on a routine basis. A duplicate sample should be processed with each analytical batch or every 10 samples. A duplicate sample should be prepared for each matrix type (i.e. sediment, sea plant, etc.).
- 7.3. A spiked sample should also be included whenever a new sample matrix is being analyzed, especially if no certified reference material is available for that matrix.
- 7.4. Blank samples should be prepared using the same reagents and quantities used in sample preparation, placed in vessels of the same type, and processed with the samples. Each microwave batch should contain at least two blank samples.

8. REFERENCES

EPA (1996) U.S. Environmental Protection Agency, EPA method 3052, Microwave assisted acid digestion of siliceous and organically based matrices Rev 0, December 2007, (<http://www.epa.gov/osw/hazard/testmethods/sw846/pdfs/3052.pdf>).

Kingston, H. M., Haswell, S (1997), Microwave Enhanced Chemistry, ACS Professional Reference.

Book Series; American Chemical Society: Washington, DC, 1997.

UNEP (2005), UNEP (DEC)/MED WG.282/inf.5/Rev1, Method for sediment sampling and analysis, February 2005, UNEP.

UNEP/IOC/IAEA (1984) reference method 7 rev2: Sampling of selected marine organisms and sample preparation for trace metal.

UNEP/IOC/IAEA (1994) reference method 57: Quality assurance and good laboratory practice, UNEP, 1994.

Annex VII:

Recommended method for the determination of selected trace element in samples of marine origin by flame atomic absorption spectrometry



Recommended method for the determination of selected trace element in samples of marine origin by flame atomic absorption spectrometry

Marine Environmental Studies Laboratory in co-operation with MED POL

November 2011

Table of Content

1. SCOPE:.....	3
2. PRINCIPLE:	4
3. SAMPLE PRE-TREATMENT:.....	4
4. REAGENT:.....	4
5. MATERIAL:.....	5
6. INTERFERENCES:.....	5
7. PROCEDURE:.....	7
8. CALCULATION OF RESULTS:	10
9. EXPRESSION OF RESULTS:.....	10
10. References:.....	11

***NOTE:** This recommended method is not intended to be an analytical training manual. Therefore the method is written with the assumption that it will be performed by formally trained analytical chemists.*

In addition the IAEA recommended methods are intended to be guidance methods that can be used by laboratories as a starting point for generating their own standard operating procedure. If performance data are included in the method they must not be used as absolute QC acceptance criteria,

The recommended protocol is mainly based on EPA 7000B method and ISO 11047 users are encouraged to consult this documents (US EPA, 2007; ISO 1998).

1. SCOPE:

This recommended method describes a protocol for measurement of Al, Ca, Co, Cr, Cu, Fe, Mg, Mn, Ni, Sr and Zn by flame (direct aspiration) atomic absorption spectrometry. The method is simple, rapid and applicable to a large number of environmental samples. This method is applicable when the element content in the digested solution is above the method limit. This limit will vary with the matrices and instrument model, indicative quantification limits are reported in table 1.

Table 1: Example of lower quantification limit for analyte in reagent water

Element	Lower quantification limit (mg l ⁻¹)
Al	0.5
Ca	0.02
Co	0.06
Cr	0.1
Cu	0.04
Fe	0.05
Mg	0.003
Mn	0.03
Ni	0.07
Sr	0.06
Zn	0.01

2. **PRINCIPLE:**

The method is based on the atomic absorption spectrometric measurement of the element in the mineralised solutions. In direct-aspiration atomic absorption spectrophotometry, the solution is aspirated and atomized in a flame. A light beam from a hollow cathode lamp or an electrodeless discharge lamp is directed through the flame into a monochromator, and onto a detector that measures the amount of absorbed light. Absorption depends upon the presence of free unexcited ground-state atoms in the flame. Because the wavelength of the light beam is characteristic of only the metal being determined, the light energy absorbed by the flame is a measure of the concentration of that metal in the sample. This principle is the basis of atomic absorption spectrophotometry.

3. **SAMPLE PRE-TREATMENT:**

Samples are prepared following the recommended method for microwave digestion of marine samples for determination of trace element content. (IAEA recommended method, 2011).

4. **REAGENT:**

All reagent used should be free of contamination of analyte of interest

4.1. Water: Reagent water (referenced also as water in the text) should be free of contamination

4.2. Caesium chloride solution, 4g l⁻¹: Dissolve 4g of CsCl of at least 99.999% purity in reagent water to 1 liter.

4.3. Caesium-Lanthanum solution: weigh 5.865g of La₂O₃ and 12.67g of CsCl in 100ml container, add 50ml of reagent water and 25ml of HCl and dilute to 100ml. Commercial solution specially produced for AAS may be used.

4.4. Commercial standard solution 1000µg ml⁻¹: Use a certified reference material solution; this solution should be accompanied by a certificate that should include at the minimum the traceability of the certified concentration as well as the expiration date. The density of the solution or the certified content in mg kg⁻¹ should also be defined to allow preparation of the calibration solution by weighing.

5. MATERIAL:

This section does not list common laboratory glassware

5.1. Atomic absorption spectrophotometer: This shall be equipped with: a hollow cathode lamp or an electrode-less discharge lamp appropriate to the element of interest (operated at the current recommended for the lamp by the instrument manufacturer), a background correction system, a burner suitable for an air/acetylene or nitrous oxide/acetylene flame (operated following the manufacturer's instructions). Deuterium background correction is the minimum technical specification acceptable for background correction for the measurement wavelengths below 350 nm.

5.2. Glassware: All glassware, polypropylene, or fluorocarbon (PFA or TFM) containers, including sample bottles, flasks and pipets tips, should be washed in the following sequence -- 24h soaking in laboratory soap (or 10% alcohol) followed by 24h soaking in 10% nitric acid, followed by 10% soaking in water, final rinse in water, drying under laminar flow hood. Cleaned items should be kept in double sealed plastic bags.

If it can be documented through an active analytical quality control program using spiked samples and method blanks that certain steps in the cleaning procedure are not needed for routine samples, those steps may be eliminated from the procedure (i.e. For the levels measured by flame AAS some sterile plastic containers are sufficiently free of contamination in certain analytes.)

5.3. Pipettes: microliter pipettes size ranging from 50 to 10000 μ l as needed. The accuracy and precision of the pipettes used should be checked as a routine every 6 months and obtained results should be compared with the individual certificates.

5.4. Volumetric containers preferably in polypropylene of a suitable precision and accuracy

6. INTERFERENCES:

6.1. The most troublesome type of interference in atomic absorption spectrometry is usually termed "chemical" and is caused by lack of absorption of atoms bound in molecular combination in the flame. This phenomenon can occur when the flame is not sufficiently hot to dissociate the molecule. The addition of chemical buffer (i.e. Lanthanum or calcium) or the use of nitrous oxide/acetylene gas mixture will help to prevent this interference.

6.2. The presence of high dissolved solids in the sample may result in interference from non-atomic absorbance such as light scattering. In the absence of background correction, this can result in false positive, signal contribution from uncorrected background which cannot be compensated by the method of standard addition.

6.3. Ionisation interference occurs when the flame temperature is sufficiently high to generate the removal of an electron from a neutral atom, giving a positively charged ion. This type of interference can generally be controlled by the addition of a large excess (~1mg l⁻¹) of an easily ionized element such as K or Cs.

6.4. Spectral interference can occur when an absorbing wavelength of an element present in the sample, but not being determined, falls within the width of the absorption line of the element of interest. This type of interference may sometimes be reduced by narrowing the slit width.

Specific conditions applied to individual analytes in case of known interferences are displayed in table 2.

Table 2: Instrument parameter

Element	Wavelength (nm)	Flame type	Chemical buffer*	Background	Typical calibration range (mg l ⁻¹)
Al	324.7	acetylene/NO ₂	Caesium chloride	Deuterium	1.5-40
Ca	422.7	acetylene/NO ₂	Caesium Lanthanum		0.02-1.2
Co	240.7	acetylene/air		Deuterium	0.06-4
Cr	357.9	acetylene/NO ₂			0.3-6
Cr	357.9	acetylene/air	Caesium chloride		0.1-6
Cu	324.7	acetylene/air		Deuterium	0.04-3
Fe	248.3	acetylene/air	Caesium chloride	Deuterium	0.05-3
Mg	285.2	acetylene/air	Caesium Lanthanum	Deuterium	0.003-0.3
Mn	279.5	acetylene/air	Caesium Lanthanum	Deuterium	0.03-3
Ni	232.0	acetylene/air		Deuterium	0.07-4
Sr		acetylene/NO ₂	Caesium chloride		0.06-5
Zn	213.9	acetylene/air		Deuterium	0.01-1.5

* see 4.2, 4.3 and 7.4 for use of chemical buffer

7. **PROCEDURE:**

7.1. Sample solution: Use sample prepared following the recommended method for digestion of marine samples for the determination of trace metal (IAEA, 2011)

7.2. Blank solution: Prepare at least two blank solutions with each batch of sample using same procedure than for samples

7.3. Preparation of calibration solutions:

7.3.1. Before each batch of determination prepare by appropriate dilution of $1000\mu\text{g ml}^{-1}$ stock standard solution (4.4) at least 4 standard solutions and one calibration blank solution covering the appropriate range of the linear part of the curve. The calibration standards and calibration blank should be prepared using the same type of acid or combination of acids and at the same concentration as will result in the test portion.

7.3.2. Calibration solutions should be prepared fresh each day.

7.3.3. If necessary intermediate stock standard solutions can be prepared in 10% nitric acid, these solutions should be prepared monthly.

7.3.4. All volumetric material (pipettes and containers) should be of appropriate precision and accuracy, if not available standard solution can be prepared by weighing.

7.3.5. Example of calibration curve are given in table 2.

7.4. Special case: Use of chemical buffer. If a chemical buffer is added, it should be at the same concentration as in the sample solution (7.1), the blank (7.2), calibration blank and standard solutions (7.3) following the recommendation of table 2.

For CsCl add 5ml of 4g l^{-1} for 50 ml of solution (4.2)

For CsLa solution add 0.5ml for 50ml of solution (4.3)

The chemical buffer will be added to a separate portion of sample and blank solutions that will need to be diluted to a known volume.

7.5. Calibration

7.5.1. Set up the atomic absorption spectrometer according to the manufacturer's instructions at the appropriate wavelength using appropriate conditions (see table 2), and with the suitable background correction system in operation.

7.5.2. Aspirate a calibration solution (7.3) and optimize the aspiration conditions, burner height and flame conditions to get the maximum signal.

7.5.3. Adjust the response of the instrument to zero absorbance whilst aspirating water

7.5.4. Aspirate the set of calibration solutions in ascending order and, as a zero member, the blank calibration solution (7.3).

NOTE: Care should be taken to ensure that, when using the more concentrated standards, the absorbance is < 1 , and preferably not more than 0,6.

The calibration curve is automatically plot from instrument software. The obtained curve should be linear with $r < 0.995$.

To correct for the instrumental drift the calibration should be performed every 20 samples or if the calibration verification has failed (7.8.1).

7.6. Aspirate blank (7.2) and sample solutions (7.1) and record their concentrations calculated by software using the calibration curve.

7.7. If the concentration of the test portion exceeds the calibration range dilute the test portion with the blank solution accordingly.

As an option to avoid too big dilution factors and/or to avoid a diluting large number of solutions, if all solutions are exceeding the calibration range, the burner can be turned from 0 to 90° to decrease the instrument's sensitivity. New calibration standard solutions should be prepared to match the sample range and the procedure should be repeated from (7.3).

7.8. Quality control solutions: Quality control solutions as describe below should be measured during the run.

7.8.1. Initial Calibration Verification ICV:

After initial calibration, the calibration curve must be verified by the use of initial calibration verification (ICV) standard.

The ICV standard is a standard solution made from an independent (second source) material at or near midrange. This solution as a calibration standard is prepared using the same type of acid or combination of acids and at the same concentration as will result in the test portion. If a chemical buffer is necessary it should be added in the ICV.

The acceptance criteria for the ICV standard must be $\pm 10\%$ of its true value

If the calibration curve cannot be verified within the specified limits, the cause must be determined and the instrument recalibrated before samples are analyzed. The analysis data for the ICV must be kept on file with the sample analysis

The calibration curve must also be verified at the end of each analysis batch and/or after every 10 samples. If the calibration cannot be verified within the specified limits, the sample analysis must be discontinued, the cause determined and the instrument recalibrated. All samples following the last acceptable test must be reanalyzed.

7.8.2. Blank solution (7.2): Maximum allowed blank concentration should be well documented and if blank solution exceeds this value all samples prepared along the contaminated blank should be prepared again and reanalysed.

7.8.3. Post digestion spike

Each unknown type of sample should be spike to check for potential matrix effect.

This spike is consider as a single point standard addition, and should be performed with a minimum dilution factor. The recovery of spike calculated as equation 1 should be 85-115%. If this test fails it is recommended to run analyses with standard addition method.

Spike solution: mix a fixe volume (V1) of sample solution, and a known volume (V2) of a standard solution of a known concentration (Cstandard)

Unspike solution: mix same fixe volume (V1) of sample solution, and same volume (V2) of reagent water

Measure concentration C (mg l^{-1}) in both solutions on the calibration curve (7.6), and calculate recovery as:

$$\text{Equation 1} \quad C_{\text{spike}} = \frac{C_{\text{standard}} \times V_2}{(V_1 + V_2)}$$

$$\text{Equation 2} \quad R = \frac{C_{\text{Spike Solution}} - C_{\text{Unspike solution}}}{C_{\text{spike}}} \times 100$$

To be valid concentrations of spike and unspike solutions should be in the linearity range of the calibration curve and the Spike concentration (equation 1) should be in the range of 50-150% of the concentration of unspike solution.

7.8.4. Dilution test:

If the analyte concentration is sufficiently high (minimally, a factor of 10 above the lower limit of quantitation after dilution), an analysis of a 1:5

dilution should agree within $\pm 10\%$ of the original determination. If not, then a chemical or physical interference effect should be suspected, and method of standard addition is recommended.

7.8.5. Certified Reference Material:

At least one certified reference material of a representative matrix should be prepared with each batch of sample, the calculated result should fall in the value of the certificate within the coverage uncertainty. (Linsinger, 2010), to show evidence of unbiased result.

Results of CRM should be recorded for quality control purpose and plot in control chart (UNEP/IOC/IAEA 1994).

An example of sequence order with recommended criteria and actions is given in table 3.

8. CALCULATION OF RESULTS:

Results are calculated with equation 3

$$\text{Equation 3: } w(m) = \frac{(\rho_1 - \rho_0)}{m} \times f \times V \times R$$

$w(m)$ mass fraction of element m in the sample in mg kg^{-1}

ρ_1 : concentration of element m in milligrams per liter as measured in the sample solution

ρ_0 : concentration of element m in milligrams per liter as measured in the blank solution

f : is the dilution factor calculated as

$$f = \frac{\text{final volume}}{\text{initial volume}}$$

or equal to 1 if ρ_1 is determined in undiluted solution

R : recovery calculated using CRM (see 7.8.5) or pre digestion spike

9. EXPRESSION OF RESULTS:

The rounding of values will depend of the uncertainty reported with the result; in general for this method no more than two significant figures will be reported.

Uncertainty component should be reported with all results. (ISO 2005, Nordtest 2004)

Example : $w(\text{Zn}) = 8.5 \pm 1.2 \text{ mg kg}^{-1}$

Table 3: Example of an analytical sequence:

Solutions Description	Performance	Action
Calibration blank	< maximum allowed calibration blank value	Stop until resolve
Standard solution 1 -4	$r > 0.995$	recalibrate in the linearity range
ICV	$\pm 10\%$ of true value	Stop until resolve
Sample blank	< maximum allowed blank value	
CRM	Fall in certificate value within coverage uncertainty, or fall within acceptable criteria of the QC chart	Stop until resolve, check Matrix spike and run again with standard addition method if necessary
Matrix Spike	recovery $100\% \pm 15\%$	switch to standard addition, keep record for future analyses of the same matrix
Dilution Test	sample 1 = 5x sample 1 diluted 5x within 10%	switch to standard addition, keep record for future analyses of the same matrix
Unknown Sample 1-10	should \geq standard 1 and \leq standard 4	report as <minimum quantification limit or dilute
ICV	$\pm 10\%$ of true value	Stop until resolve
Unknown Sample 11-20	should \geq standard 1 and \leq standard 4	report as <minimum quantification limit or dilute
Calibration blank	< maximum allowed calibration blank value	Stop until resolve
Standard solution 1 -4	$r > 0.995$	recalibrate in the linearity range
ICV	$\pm 10\%$ of true value	Stop until resolve
Ect....		

10. REFERENCES:

EPA (2007) U.S. Environmental Protection Agency, EPA method 7000B: Flame Atomic Absorption Spectrophotometry, Rev 2, Febuary 2007, (<http://www.epa.gov/osw/hazard/testmethods/sw846/pdfs/7000b.pdf>)

IAEA (2011) IAEA Recommended method for microwave digestion of marines samples for the determination of trace element content, 2011, *in preparation*, available upon request

ISO (1995) Guide to the expression of uncertainty of measurements International Organisation for Standardization: Geneva

ISO (1998) International Standard Organisation 11047:1998 Soil quality- determination of Cadmium, chromium, copper, lead, manganese, nickel and zinc in aqua regia extracts of soil- flame and electrothermal atomic absorption spectrometric methods, ISO geneva

Linsinger, T. (2010), European Commission - Joint Research Centre, Institute for Reference Materials and Measurements (http://www.erm-crm.org/ERM_products/application_notes/application_note_1/Documents/erm_application_note_1_english_rev3.pdf)

Nordtest (2004) Handbook For Calculation Of Measurement Uncertainty In Environmental Laboratories Edition 2 <http://www.nordicinnovation.net/nordtestfiler/tec537.pdf>)

UNEP/IOC/IAEA (1994) reference method 57: Quality assurance and good laboratory practice, UNEP, 1994

Annex VIII:

Recommended method for the determination of selected trace element in samples of marine origin by atomic absorption spectrometry using graphite furnace



Recommended method for the determination of selected trace element in samples of marine origin by atomic absorption spectrometry using graphite furnace

Marine Environmental Studies Laboratory in co-operation with MED POL

November 2011

Table of content

1. SCOPE:.....	3
2. PRINCIPLE:.....	3
3. SAMPLE PRE-TREATMENT:	4
4. REAGENTS:	4
5. MATERIALS:	6
6. INTERFERENCES:	6
7. CHEMICAL MODIFICATION:.....	7
8. PROCEDURE	8
9. CALCULATION OF RESULTS:	14
10. EXPRESSION OF RESULTS:	14
11. REFERENCES:.....	14
Table 1 Approximate characteristic masses and typical working range	3
Table 2 Recommended chemical modifiers	8
Table 3 Example of temperature program	9
Table 4 Example of analytical sequence:	12

***NOTE:** This recommended method is not intended to be an analytical training manual. Therefore the method is written with the assumption that it will be performed by formally trained analytical chemist.*

In addition, the IAEA recommended methods are intended to be guidance methods that can be used by laboratories as a starting point for generating their own standard operating procedure. If performance data are included in the method they must not be used as absolute QC acceptance criteria.

The recommended protocol is mainly based on EPA 7010 method and ISO 15586 users are encouraged to consult this documents (US EPA, 2007; ISO 2003)

1. **SCOPE:**

This International Standard includes principles and procedures for the determination of trace levels of: As, Cd, Co, Cr, Cu, Ni, Pb, and V in samples from marine origin, using atomic absorption spectrometry with electro thermal atomization in a graphite furnace. The method is applicable to the determination of low concentrations of elements. The detection limit of the method for each element depends on the sample matrix as well as the instrument, the type of atomizer and the use of chemical modifiers. Table 1 gives approximate working range and characteristic masses.

Table 1 Approximate characteristic masses and typical working range using 20µl sample volume

Element	Characteristic mass M_0^* pg	Working range ng ml ⁻¹
As	15	5-50
Cd	0.8	0.2-2
Co	10	3-30
Cr	3	2-20
Cu	10	3-30
Ni	13	5-50
Pb	15	5-50
V	35	10-100

**The characteristic mass (m_0) of an element is the mass in pg corresponding to a signal of 0.00044 unity using peak area as integration*

2. **PRINCIPLE:**

An aliquot of sample solution (5-50 μL) is introduced into a graphite tube of the GF AAS and atomized by rapid heating at high temperature. A light beam is directed through the graphite tube, into a monochromator, and onto a detector that measures the amount of light absorbed by the atomized element in the tube. Each metal has its own characteristic wavelength therefore a source hollow cathode lamp composed of that element is used. The amount of energy absorbed at the characteristic wavelength is proportional to the concentration of the element in the sample.

3. **SAMPLE PRE-TREATMENT:**

Samples are prepared following the recommended method for microwave digestion of marine samples for determination of trace element content. (IAEA recommended method, 2011)

4. **REAGENTS:**

4.1. Water: Reagent water (referenced also as water in the text) should be free of contamination

4.2. Concentrated acid solution as used for sample preparation (section 3)

4.3. Commercial standard solution $1000\mu\text{g ml}^{-1}$: Use certified reference material solution; this solution should be accompanied by a certificate that should include at least the traceability of the certified concentration as well as the expiration date. The density of the solution or the certified content in mg kg^{-1} should also be defined to allow preparation of calibration solution by weighing.

4.4. Calibration solutions: Prepare calibration solutions from the standard solutions (4.3) by appropriate dilution. Intermediate standard solutions should be prepared in 2% (v/v) nitric acid. For calibration solution use the same amount of acid as that of the samples solutions.

Calibration solutions below 1 mg/l should not be used for more than one month, and those below 100 $\mu\text{g/l}$ should not be used for more than one day.

4.5. Blank calibration solution: Prepare a blank calibration solution in the same way as the calibration solution but without adding standard. The final amount of acid will be the same as that of the sample solutions.

4.6. Palladium nitrate/magnesium nitrate modifier

Pd(NO₃)₂ solution is commercially available (10 g/l). Dissolve 0,259 g of Mg(NO₃)₂·6H₂O in 100 ml of water. Mix the palladium nitrate solution with twice as much magnesium nitrate solution. 10 µl of the mixed solution is equal to 15 µg Pd and 10 µg Mg(NO₃)₂. The mixture is also commercially available.

Prepare a fresh solution monthly.

4.7. Magnesium nitrate modifier

Dissolve 0,865 g of Mg(NO₃)₂·6H₂O in 100 ml of water. 10 µl of this solution is equal to 50 µg Mg(NO₃)₂.

4.8. Ammonium dihydrogen phosphate modifier

Dissolve 2,0 g of NH₄H₂PO₄ in 100 ml of water. 10 µl of this solution is equal to 200 µg NH₄H₂PO₄.

4.9. Ammonium dihydrogen phosphate/magnesium nitrate modifier

Dissolve 2,0 g of NH₄H₂PO₄ and 0,173 g of Mg(NO₃)₂·6H₂O in 100 ml of water. 10 µl of this solution is equal to 200 µg NH₄H₂PO₄ and 10 µg Mg(NO₃)₂.

4.10. Palladium/Ammonium dihydrogen phosphate/magnesium nitrate modifier

Mix 2ml of Pd(NO₃)₂ solution is commercially available (10 g/l), 2ml of Mg(NO₃)₂ solution prepared as (4.7), 0.5ml of NH₄H₂PO₄ prepared as (4.8) and dilute with water to 10ml. 4µl of this solution is equal to 8µg of Pd, 4µg of Mg(NO₃)₂ and 4µg of NH₄H₂PO₄.

4.11. Nickel modifier

Dissolve 0,200 g of nickel powder in 1 ml concentrated nitric acid and dilute to 100 ml with water. 10 µl of this solution is equal to 20 µg Ni. Solutions of Ni(NO₃)₂ are also commercially available.

4.12. Iridium solution 1000µg ml⁻¹

Use commercial solution (standard)

4.13. Argon

5. MATERIALS:

5.1. Glassware: All glassware, polypropylene, or fluorocarbon (PFA or TFM) containers, including sample bottles, flasks and pipettes tips, should be washed in the following sequence -- 24h soaking in laboratory soap (or 10% alcohol) followed by 24h soaking in 10% nitric acid, followed by 10% soaking in water, final rinsing in water, drying under laminar flow hood. Cleaned items should be kept in double sealed plastic bags

5.2. Pipettes: microliter pipettes size ranging from 50 to 10000 μ l as needed. The accuracy and precision of the pipettes used should be checked as a routine every 6 months and the obtained results should be compared with the individual certificates.

5.3. Volumetric containers preferably in polypropylene of suitable precision and accuracy

5.4. Atomic Absorption Spectrometer equipped with graphite furnace, background correction system and necessary hollow cathode lamp.

5.5. Auto sampler

5.6. Polypropylene cups for automatic sampler cleaned as explained in (5.1)

5.7. Graphite tubes: pyrolytically-coated with platforms, preferably for highly and medium volatile elements, whereas elements of low volatility should be atomized from the wall. Provided satisfactory results are achieved, manufacturer's recommendations regarding the use of graphite tubes and platforms should be followed.

6. INTERFERENCES:

Some sample solutions, may contain large amounts of substances that may affect the results. High concentrations of chloride may cause low results, because the volatility of many elements is increased and analyte loss may occur during the pyrolysis step. Matrix effects may be overcome, partially or completely, by the optimization of the temperature program, the use of pyrolytically-coated tubes and platforms, the use of chemical modifiers, the standard addition technique and the use of background correction.

7. CHEMICAL MODIFICATION:

Chemical modifiers are used to overcome spectral and/or non-spectral interferences in a sample (matrix effects). In general, the aim of chemical modification is to allow a pyrolysis temperature that is high enough to remove the bulk of concomitants before the atomization step. In order to ascertain that the modification works, the spike procedures is performed with and without the addition of a chosen chemical modifier and recovery are compared

Spike experiment:

Spike solution: mix a fixe volume (V1) of sample solution, and a known volume (V2) of a standard solution of a known concentration (C_{standard})

Unspike solution: mix same fixe volume (V1) of sample solution, and same volume (V2) of reagent water

Measure concentration C (mg l⁻¹) in both solutions on the calibration curve, and calculate recovery as:

$$\text{Equation 1} \quad C_{\text{spike}} = \frac{C_{\text{standard}} \times V_2}{(V_1 + V_2)}$$

$$\text{Equation 2} \quad R = \frac{C_{\text{Spike Solution}} - C_{\text{Unspike solution}}}{C_{\text{spike}}} \times 100$$

To be valid concentrations of spike and unspike solutions should be in the linearity range of the calibration curve and Spike concentration (equation 1) should be in the range of 50-150% of the concentration of unspike solution. The recovery should be 100 ± 15%

In Table 2 some recommendations of chemical modifiers are given.

Other chemical modifiers may be used if they show consistent results. Graphite tube can also be pretreated with Iridium (Vasileva 2001) as following:

Inject 50µl of the solution and run the temperature program below

Step	Temperature (°C)	Ramp Time (s)	Hold Time (s)
1	100	5	30
2	1200	20	5
3	100	5	2
4	2500	2	10

Repeat this 3 times, the coating is stable for about 200 injections and can be repeated

If chemical modifiers are used, add them to test samples, sample blank solutions, calibration solutions, and blank calibration solutions. Preferably inject the modifier solution with the auto sampler directly into the atomizer after the sample is delivered.

Table 2 Recommended chemical modifiers

Element	Chemical modifier	Amount* µg
As	Pd + Mg(NO ₃) ₂ or NH ₄ H ₂ PO ₄	15+10 200
Cd	Pd + Mg(NO ₃) ₂ +NH ₄ H ₂ PO ₄ or Ir coating	8+4+4
Co	Pd + Mg(NO ₃) ₂	15+10
Cr	Mg(NO ₃) ₂	50
Cu	None	
Ni	Mg(NO ₃) ₂	50
Pb	Pd + Mg(NO ₃) ₂ +NH ₄ H ₂ PO ₄ or Ir coating	8+4+4
V	None	

*These amounts are only recommendation, significantly lower amounts may be required in some atomizers, see also recommendations from instrument manufacturers.

8. PROCEDURE

8.1. Switch on the instrument and perform the optimization according to the manufacturer's instructions. Install an appropriate graphite tube, and set up the auto sampler.

8.2. Program the graphite furnace and the auto sampler. Examples of temperature program are given in table 3.

Note: Method for specific element and matrix should be developed and all necessary information should be stored with at least:

- *Temperature program*
- *Matrix modifier*
- *Type of graphite tube*
- *Matrix effect*
- *Type of calibration curve*
- *Typical m_0 obtained with the program*
- *Linearity*

Table 3 Example of temperature program

Element	Cu	Cu	Cd	Cd	Pb	Pb	As	As	Cr	Cr
Sample type	Sediment	Biota	Sediment	Biota	Sediment	Biota	Sediment	Biota	Sediment	Biota
Wavelength(nm)	327.4	327.4	228.8	228.8	283.3	283.3	193.7	193.7	357.9	357.9
Graphite tube	Partition Tube	Partition Tube	platform	platform	platform	platform	platform	platform	Partition Tube	Partition Tube
Matrix Modifier	none	none	none	Pd,Mg, Amonium Phosphate	none	Pd,Mg ,Amonium Phosphate	Pd,Mg	Pd,Mg	none	none
Peak Measurement	area	area	area	area	area	area	area	area	area	area
M0(pg/0.0044 UA) on standard	13	13	1	1	16	16	15	15	2.5	2.5
Ashing T° (C°)	700	700	300	700	400	925	1400	1400	1100	1100
Atomisation T° (C°)	2300	2300	1800	1900	2100	2200	2600	2600	2600	2600
Remark							Number of Fire is critical	Standard Addition often required. Number of fire is critical	Use peak Height for lower concentration (peak shape)	Standard Addition often required. Use peak Height for lower concentration (peak shape)

8.3. Generality for measurements:

All measurements should be performed with at least duplicate injections of solutions; the relative standard deviation should be less than 5% for a signal above 0.01 unit of absorbance.

It is recommended to work in peak area.

Check the number of firing and change the graphite tube when appropriate, if graphite tube is changed during a run, the instrument needs to be recalibrated.

8.4. Run the calibration:

8.4.1. **Standard calibration technique:** Perform the calibration with a blank calibration solution (4.5) and 3 to 5 equidistant calibration solutions (4.4) for an appropriate concentration range.

To correct for the instrumental drift calibration should be performed every 10 samples (if possible the option of reslope using the middle standard point should be applied every 5 samples)

Calibration solutions can be prepared by the auto sampler from the highest standard solution, the minimum volume uptake should not be less than 4 μ l.

The blank calibration solution should be free of analyte, or below a well-documented maximum allowed calibration blank value (i.e. validation, control charts..).

It should be stressed that the linearity of the calibration curve is often limited. The calibration curve is automatically plot by instrument software, if linear regression is set checked that $r \leq 0.995$ or switch to second order equation.

8.4.2. **Standard addition method:** This technique involves preparing same aliquots of sample solution with increasing amount of analyte. As describe in section 7 for the spike experiment using an increasing concentration of standard (V1 and V2 should stay the same). The auto sampler can be prograded to perform standard addition. Determine the analyte concentration in the reagent blank solution the same way. Example of standard addition is given in figure 1. The concentration is obtained by dividing the absorbance of zero addition by the slope.

The standard addition should be performed for each type of matrix (i.e. a sediment sample solution cannot be measured with a standard addition curve done on a fish sample solution). For similar sample matrices (i.e. same fish species) the slope obtained with one sample can be used for other measurements respecting recalibration every 10 samples.

For standard addition to be valid the following limitation should be taken into consideration:

- The resulting calibration should be linear ($r \leq 0.995$), software calibration equation is a linear regression
- The additions should represent ideally 50, 100, 150 and 200% of the sample concentration
- The standard addition technic cannot be used to correct for spectral interferences, such as unspecific background absorption, and should not be used if interferences change the signal by a factor of more than three.

Figure 1 Standard addition example

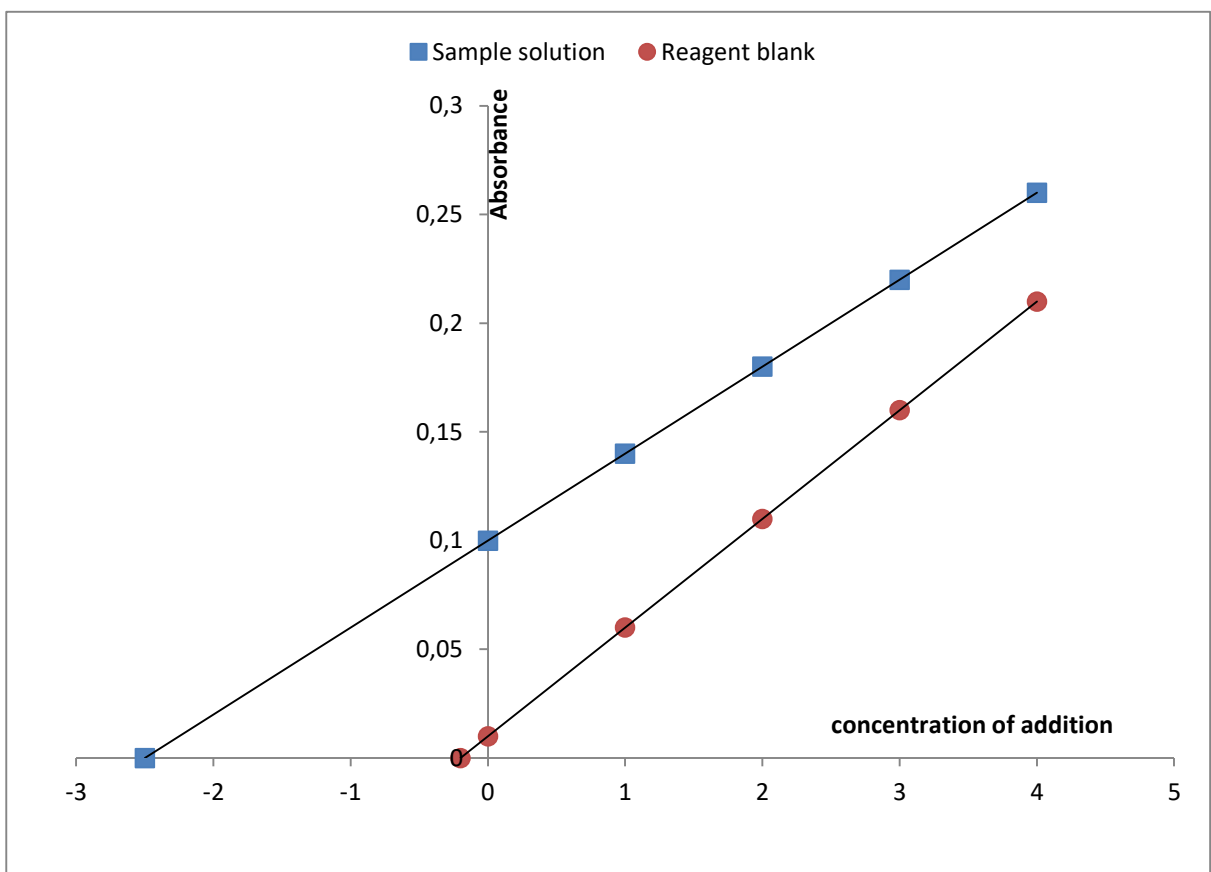

8.5. Measure sample blank and sample solutions (prepared following section 3) record the concentration as calculated by the software and calculate results following equation 3 (section 9), if samples exceed the highest point of calibration dilute appropriately. As an option a smaller volume of solution can be injected to stay under linear range of the instrument.

8.6. Quality control solutions: Quality control solutions as described below should be measured during the run. An example of a sequence order with recommended criteria and action is given in table 4.

Table 4 Example of analytical sequence:

Solutions Description	Performance	Action
Calibration blank	< maximum allowed calibration blank value	Stop until resolve
Standard solution 1 -4	$r > 0.995$	recalibrate in the linearity range
ICV	$\pm 10\%$ of true value	Stop until resolve
Sample blank	< maximum allowed blank value	
CRM	Fall in certificate value within coverage uncertainty, or fall within acceptable criteria of the QC chart	Stop until resolve, check Matrix spike and run again with standard addition method if necessary
Matrix Spike	recovery $100\% \pm 15\%$	switch to standard addition, keep record for future analyses of the same matrix
Dilution Test	sample 1 = 5x sample 1 diluted 5x within 10%	switch to standard addition, keep record for future analyses of the same matrix
Unknown Sample 1-10	should \geq standard 1 and \leq standard 4	report as <minimum quantification limit or dilute

ETC...(restart sequence from calibration blank)

8.6.1. Initial Calibration Verification ICV:

After the initial calibration, the calibration curve must be verified using the initial calibration verification (ICV) standard.

The ICV standard is a standard solution made from an independent (second source) material at or near midrange. This solution as calibration standard is prepared using the same type of acid or combination of acids and at the same concentration as will result in the test portion.

The acceptance criteria for the ICV standard must be $\pm 10\%$ of its true value

If the calibration curve cannot be verified within the specified limits, the cause must be determined and the instrument recalibrated before samples are analyzed.

The analysis data for the ICV must be kept on file with the sample analysis

The calibration curve must also be verified at the end of each analysis batch and/or after every 10 samples. If the calibration cannot be verified within the specified limits, the sample analysis must be discontinued, the cause determined and the instrument recalibrated. All samples following the last acceptable test must be reanalyzed.

8.6.2. **Blank solution (4.5):** Maximum allowed blank concentration should be well documented and if blank solution exceeds this value all samples prepared along the contaminated blank should be prepared again and re analyzed.

8.6.3. **Post digestion spike**

Each unknown type of sample should be spike to check for potential matrix effect.

This spike is consider as a single point standard addition, and should be performed with a minimum dilution factor. Recovery of spike calculated as equation 1 should be 85-115%. If this test failed it is recommended to run analyses with standard addition method. (see section 7 for detail)

8.6.4. **Dilution test:**

If the analyte concentration is sufficiently high (minimally, a factor of 10 above the lower limit of quantitation after dilution), an analysis of a 1:5 dilution should agree within $\pm 10\%$ of the original determination. If not, then a chemical or physical interference effect should be suspected, and method of standard addition is recommended.

8.6.5. **Certified reference material:**

At least one certified reference material of a representative matrix will be prepared with each batch of sample, the calculated result should be comparable with the value of the certificate within the coverage uncertainty.(Linsinger, 2010), to show evidence of unbiased result.

Results of CRM should be record for quality control purpose and plot in control chart (UNEP/IOC/IAEA 1994)

9. CALCULATION OF RESULTS:

Results are calculated with equation 3

$$\text{Equation 3: } w(m) = \frac{(\rho_1 - \rho_0)}{m} \times f \times V \times R$$

w(m) mass fraction of element m in the sample in mg kg⁻¹

ρ1: concentration of element m in milligrams per liter as measured in the sample solution

ρ0: concentration of element m in milligrams per liter as measured in the blank solution

f: is the dilution factor calculated as

$$f = \frac{\text{final volume}}{\text{initial volume}}$$

or equal to 1 if ρ1 is determined in undiluted solution

R: recovery calculated using CRM (see 8.6.5) or pre digestion spike

10. EXPRESSION OF RESULTS:

The rounding of values will depend of the uncertainty reported with the result. Uncertainty component should be reported with all results. (ISO 1995, Nordtest 2004)

Example : w(Pb) = 8.5 ± 1.2 mg kg⁻¹

11. REFERENCES:

EPA (2007) U.S. Environmental Protection Agency, EPA method 7010: Graphite furnace Atomic Absorption Spectrophotometry, Rev 0, February 2007, (<http://www.epa.gov/osw/hazard/testmethods/sw846/pdfs/7010.pdf>)

IAEA (2011) IAEA Recommended method for microwave digestion of marines samples for the determination of trace element content, 2011, *in preparation*, available upon request

ISO (1995) Guide to the expression of uncertainty of measurements International Organisation for Standardization: Geneva

ISO (1998) International Standard Organisation 11047:1998 Soil quality- determination of Cadmium, chromium, copper, lead, manganese, nickel and zinc in aqua regia extracts of soil-flame and electrothermal atomic absorption spectrometric methods, ISO geneva

Linsinger, T. (2010), European Commission - Joint Research Centre, Institute for Reference Materials and Measurements (http://www.erm-crm.org/ERM_products/application_notes/application_note_1/Documents/erm_application_note_1_english_rev3.pdf)

Nordtest (2004) Handbook For Calculation Of Measurement Uncertainty In Environmental Laboratories Edition 2 <http://www.nordicinnovation.net/nordtestfiler/tec537.pdf>

UNEP/IOC/IAEA (1994) reference method 57: Quality assurance and good laboratory practice, UNEP, 1994

Vasileva. E, Baeten. H, Hoenig. M (2001), Advantages of the iridium permanent modifier in fast programs applied to trace-element analysis of plant samples by electrothermal atomic absorption spectrometry, *Fresenius J Anal Chem* (2001) 369 :491–495

Annex IX:

HELCOM

**Manual for marine monitoring in the COMBINE programme
ANNEX B-12, APPENDIX 4: TECHNICAL NOTE ON THE DETERMINATION OF TRACE
METALLIC ELEMENTS IN BIOTA**

HELCOM Manual for marine monitoring in the COMBINE programme

ANNEX B-12, APPENDIX 4: TECHNICAL NOTE ON THE DETERMINATION OF TRACE METALLIC ELEMENTS IN BIOTA

1. INTRODUCTION

Metallic elements appear in different marine biological matrices in trace concentrations, ranging from the mg/kg through the $\mu\text{g}/\text{kg}$ to the ng/kg level. Stoeppler (1991) provided a comprehensive review of the most frequently used techniques for quantitative analysis of metallic trace elements, such as optical atomic absorption, fluorescence or emission spectrometry, anodic, cathodic or adsorptive stripping voltammetry, isotope dilution mass spectrometry and total reflection X-ray fluorescence, respectively. In spite of the powerful instrumental techniques presently in use, various analytical error sources have to be taken into consideration that may significantly influence the accuracy of the analytical data.

2. WORKING CONDITIONS

For each step of the analytical procedure, contamination of the sample may occur from the environment (laboratory air dust particles and the analyst), from sample containers or packing materials, from instruments used during sample pre-treatment and sample preparation, and from the chemical reagents used for analysis. The predominant purpose of the analytical clean laboratory is to eliminate contamination, which may be airborne or laboratory-induced, as far as possible and to control the total analytical blank.

Contamination by particles from the laboratory air may be controlled by a high-efficiency particulate filter. (A clean room is designed to maintain air with 100 particles per ft³ or 3.6.10³ per m³ of 0.5 μm particles (class 100 of U.S. Federal Standards 209), or better, preferably with a minimum of activity in the room.) U.S. Federal Standards 209 describes designs for complete laminar flow rooms, clean benches, and fume hoods, and contains information on design, testing, and maintenance of clean rooms, and should be considered an essential reference for those interested in a clean laboratory.

To control the analytical blank for analysis of metallic trace elements, one must not only maintain good laboratory air quality, but also select the appropriate composition and type of construction materials used to build the laboratory. Principally, contaminants must be effectively removed at the source to minimize their uncontrolled distribution in the analytical clean laboratory. Accordingly, the laboratory's walls should be cleaned easily and therefore painted with special metal-free wipe-resistant paints. Surfaces of working areas should be protected with, for example, disposable plastic (polyethylene, PTFE) foils. The floors should, for example, be covered with adhesive plastic mats. Details of the design that are essential for obtaining a working laboratory with low trace element blanks are described by Moody (1982), Mitchell (1982a), Boutron (1990), and Schmidt and Gerwinski (1994).

3. PRETREATMENT OF LABORATORY WARE AND REAGENTS, CONTAMINATION CONTROL

Chemically resistant materials, used in the production of high-quality laboratory ware appropriate for metallic trace element analysis, include low- and high-density polyethylene (LDPE and HDPE), polypropylene (PP), polytetrafluorethylene (PTFE), perfluoralkoxy (PFA), ethylenetetrafluorethylene (ETFE), tetrafluorethylenepolypropylene (FEP), borosilicate and quartz glass, respectively. With appropriate pretreatment and handling, these materials meet the requirements of purity necessary for the required analytical investigations.

Cleaning procedures for plastic and glass laboratory ware were comprehensively dealt with by Moody and Lindstrom (1977), Tschopel et al. (1980), Kosta (1982) and Boutron (1990). Generally, immersion in diluted (10-25 % v/v) high-purity nitric acid at room temperature for a period of one to three days, followed by repeated rinsing with high-purity water, is recommended. Steaming in high-purity acids (predominantly nitric acid) is also very effective to remove impurities from container surfaces and condition them for subsequent analysis.

The materials mentioned above for the production of laboratory ware exhibit some adsorptive or exchange properties. Boundary-surface interactions can be important, particularly when very dilute analytical solutions are being handled, since uncontrollable losses through sorption of element ions can occur (Tschopel et al., 1980; Harms, 1985). Based on this information, it is imperative that volumetric flasks, reagent vessels, pipette tips, etc., for handling samples, sample solutions and low-level reference or analyte solutions must never be used for transferring or processing stock calibration solutions, analyte solutions or concentrated reagents. Considerable quantities of analytes may be adsorbed from such solutions by the respective container surfaces, residuals of which may be leached later when dilute sample or analyte solutions are handled.

The availability of high-purity reagents is a key condition for reliable investigations of metallic trace element concentrations. For many analytical problems, the level of a specific contaminant can adequately be controlled only by applying specific purification methods. The first order of priority in regard to high-purity reagents is a sufficient supply of high-purity water. Ion-exchange units are universally accepted as an effective means of removing dissolved ionic species from water. Since high-purity water is frequently used in metallic trace element analysis, equipment for sustainable production of high-purity water by high-purity mixed-bed ion exchange resins should be available. The next most important group of reagents are mineral acids. Contamination of the sample by residual concentrations of metallic trace elements in the acids used for dissolution or decomposition represents a major problem. Purification of the acids is essential to ensure acceptable blanks.

Isothermal (isopiestic) distillation can produce volatile acids (and ammonia) of medium concentration in high-purity form. For example, pure hydrochloric acid (and ammonia) can be generated by placing an open container of concentrated reagent-grade acid adjacent to a

container of high-purity water, within a closed system (such as a desiccator) at room temperature. Acid vapours are continuously transferred into the water until equilibrium is obtained. Purification by sub-boiling distillation is based on motionless evaporation of the liquid by infrared heating at the surface to prevent violent boiling. Different purification systems are described in detail by Matthinson (1972), Kuehner et al. (1972), Dabeka et al. (1976), Tschopel et al. (1980), Mitchell (1982b), Moody and Beary (1982), Moody et al. (1989), and Paulsen et al. (1989). Acids of extremely high purity are produced by multiple batchwise distillation of reagent-grade acids in a silica apparatus, which is placed in a laminar-flow hood.

4. SAMPLE PRETREATMENT

If the determinands are heterogeneously distributed in the sample material, it may be preferable to homogenize prior to taking subsamples for analysis. However, this procedural step is problematic, since uncontrollable contamination through the homogenizing tool may occur. Cryogenic homogenization at liquid nitrogen temperature and application of high-purity material such as quartz, PTFE, titanium or stainless steel for the construction of homogenizing devices may help to minimize contamination (Iyengar, 1976; Iyengar and Kasperek, 1977; Klusmann et al., 1985).

5. SAMPLE DECOMPOSITION

For accurate direct measurements of metallic trace element contents in biological matrices, appropriate calibration (reference) standards are lacking in most instances. Therefore, multi-stage, easy to calibrate methods are still necessary, which include decomposition procedures and transformation of biological material into solution.

As a general rule wet sample is to be subject to decomposition procedures to avoid contamination or loss of determinands. A general sample decomposition procedure cannot be recommended due to the diverse composition of materials to be analysed, as well as to the different elements to be determined, and also because of the variety of possible analytical methods applied. However, the following minimum requirements should be met:

- complete destruction of all organic material of the sample,
- avoidance of determinand losses,
- avoidance of contamination.

Complete decomposition of the organic matrix is a prerequisite for a variety of the subsequently used instrumental determination techniques. Residual dissolved organic carbon from biological materials incompletely disintegrated after decomposition with nitric acid causes problems particularly in voltammetric and polarographic determinations. Both are sensitive to interference from chelating and electroactive organic components coexisting in incompletely decomposed samples during analysis (Pratt et al., 1988; Wurfels

et al., 1987, 1989). Residual dissolved organic carbon compounds even of low molecular weight can change the equilibria in the spray chambers for sample introduction in atomic emission spectrometry (AES), optical emission spectrometry (OES), and atomic absorption spectrophotometry (AAS) by changing the viscosity of the sample solution. In such cases, comparison with pure aquatic calibration standard solutions can lead to erroneous results. In graphite furnace atomic absorption spectrophotometry (GFAAS), residual organic carbon may undergo complicated secondary reactions with the analyte prior to or during the atomization process. Such 'matrix interferences' alter the rate at which atoms enter the optical path relative to that obtained for an undisturbed element standard (Harms, 1985; and other references cited there).

The comparatively simple dry ashing method using a muffle furnace is problematic, since both uncontrollable losses of the determinands and contamination through contact with the furnace material may occur.

Both, application of a carefully developed and controlled temperature programme and modifying the matrix prior to the ashing procedure (addition of ashing aids agents) may be suitable to prevent losses of volatile elements (special analytical problems concerning mercury determination are described in Attachment 1). The use of special materials (quartz, titanium, stainless steel) for the construction of sample containers may be helpful to minimise contamination.

In the widely applied wet ashing procedure in open systems, the sample is treated with acids, mainly nitric, sulphuric and perchloric acids, in different ratios and under different conditions. Usually large quantities of reagents and voluminous apparatus with large surfaces are needed for complete destruction of the organic material. Serious contamination problems (too high blank values) may arise, if insufficiently purified acids are used.

The rate of reaction and efficiency of acid decomposition increase substantially with elevated temperatures. Accordingly, closed-vessel techniques, using conventional heating or microwave energy, have an advantage over open systems. As a result of the closed systems with vessels manufactured of dense and very pure material (PTFE, PFA, quartz), loss of elements through volatilisation and contamination by desorption of impurities from the vessel surface are significantly reduced. In addition, since only small quantities of high-purity acid (usually nitric acid) need to be used, extremely low analytical blanks can be obtained. Kingston and Jassie (1986, 1988) comprehensively considered the fundamental parameters governing closed vessel acid decomposition at elevated temperatures using a microwave radiation field. Microwave systems enable a very fast energy transfer to the sample and a very rapid build up of high internal vessel temperature and pressure, with the advantage of an enormous reduction in digestion time occurs. Furthermore, a reduction of acid volume

(McCarthy and Ellis, 1991) and contamination reduction during the decomposition process were found (Dunemann, 1994; Sheppard et al., 1994).

The application of microwave energy must be carefully controlled to avoid explosions; a pressure-relief system is recommended for safe operation (Gilman and Grooms, 1988). At this stage of development, it can be concluded that advances in pressure and temperature feedback control features have contributed to the acceptance of microwave sample decomposition in analytical chemistry.

6. CALIBRATION

For calibration purposes, single element standard stock solutions at a concentration of 1000 mg/l, purchased from a qualified manufacturer, should be available. The actual concentration of the named element should be stated on the label together with the date of the preparation of the standard solution.

Fresh stock standard solutions should be compared with the old standard solutions. Traceability can be ensured by the use of CRM(s) or participation in intercomparison exercises (EURACHEM, 2003).

Single or mixed element working standard solutions for calibration purposes are prepared by dilution of the standard stock solutions using dilute acid, as required. Both stock standard and working standard solutions are stored in polyethylene, borosilicate or quartz volumetric flasks. Working standard solutions at concentrations less than 100 µg/l should be freshly prepared for every batch of samples and kept no longer than two weeks. The calibration procedure must meet some basic criteria in order to give the best estimate of the true (but unknown) element concentration of the sample analysed. These criteria are as follows:

- The amounts or concentrations of standards for the establishment of the calibration function must cover the range as related to practical conditions. The mean of the range should be roughly equal to the expected analyte concentration in the sample.
- The required analytical precision must be achievable and known throughout the entire range.
- The measured value (response) at the lower end of the range must be significantly different from the procedural analytical blank.
- The chemical and physical properties of the calibration standards must closely resemble those of the sample under investigation.
- The calibration standards must be processed through the entire analytical procedure in the same manner as the sample.

- The standard addition technique should be used only under very special circumstances (Cardone, 1986a, 1986b).

7. DETERMINATION

In an analytical series, especially with the number of samples >10, the control of calibration settings should be carried out with 2-3 calibration solution between environmental 10 samples. The analytical series should contain also a control sample of LRM or CRM.

8. REFERENCES

- Baxter, D., and Frech, W. 1990. Critical comparison of two standard digestion procedures for the determination of total mercury in natural water samples by cold vapour atomic absorption spectrometry. *Analytica Chimica Acta*, 236: 377-384.
- EURACHEM 2003. EURACHEM/CITAC Guide "Traceability in Chemical Measurement" – A guide to achieving comparable results in chemical measurement. S.L.R. Ellison, B. King, M. Rösslein, M. Salit, A. Williams (Eds.), 43 pp.
- Feldman, C. 1974. Preservation of dilute mercury solutions. *Analytical Chemistry*, 46: 99-102.
- Guo, T., and Baasner, J. 1993. Determination of mercury in urine by flow-injection cold vapour atomic absorption spectrometry. *Analytica Chimica Acta*, 278: 189-196.
- Hanna, C., and McIntosh, S. 1995. Determination of total Hg in environmental samples with on-line microwave digestion coupled to a flow injection mercury system (FIMS). *Atomic Spectroscopy*, 16: 106-114.
- Harms, U. 1988: Analytical procedures for mercury, cadmium and lead in biological material. *Baltic Sea Environment Proceedings*, No. 27C, Part CI, pp. 36-62. Helsinki Commission.
- Hatch, W., and Ott, W. 1968. Determination of sub-microgram quantities of mercury by atomic absorption spectrometry. *Analytical Chemistry*, 40: 2085-2087.
- Kaiser, G., Götz, D., Tölg, G., Knapp, G., Maichin, B., and Spitzzy, H. 1978. Untersuchung von systematischen Fehlern bei der Bestimmung von Hg-Gesamtgehalten im Bereich 10 -5 % in anorganischen und organischen Matrices mit zwei unabhängigen Verbundverfahren. *Fresenius Z. Analytical Chemistry*, 291: 278-291.
- Kingston, K., and McIntosh, S. 1995. Determination of mercury in geological samples by flow injection AAS. *Atomic Spectroscopy*, 16: 115-117.
- Landi, S., Fagioli, F., Locatelli, C., and Vecchiotti, R. 1990. Digestion method for the determination of mercury in vegetable matrices by cold vapour atomic absorption spectrometry. *Analyst*, 115: 173-177.
- Lippo, H., Jauhiainen, T., and Perämäki, P. 1997. Comparison of digestion methods for the determination of total mercury in environmental samples by flow injection CV-AAS. *Atomic Spectroscopy*, 18: 102-108.

- Navarro, M., Lopez, M., Lopez, H., and Sanchez, M. 1992. Microwave dissolution for the determination of mercury in fish by cold vapour atomic absorption spectrometry. *Analytica Chimica Acta*, 257: 155-158.
- Ping, L., and Dasgupta, P. 1989. Determination of total mercury in water and urine by gold film sensor following Fenton's Reagent digestion. *Analytical Chemistry*, 61: 1230-1235. Rokkjaer, J., Hoyer, B., and Jensen, N. 1993. Interference by volatile nitrogen oxides in the determination of mercury by flow injection cold vapour atomic absorption spectrometry. *Talanta*, 40: 729-735.
- Toffaletti, J., and Savory, J. 1975. Use of sodium borohydride for determination of total mercury in urine by atomic absorption spectrometry. *Analytical Chemistry*, 47: 2091-2095.
- Toribara, T., Shields, C., and Koval, L. 1970. Behaviour of dilute solutions of mercury. *Talanta*, 17: 1025-1028. Tsalev, D., Sperling, M., and Welz, B. 1992a: On-line microwave sample pre-treatment for hydride generation and cold vapour atomic absorption spectrometry. Part 1. The manifold. *Analyst*, 117: 1729-1733.
- Tsalev, D., Sperling, M., and Welz, B. 1992b. On-line microwave sample pre-treatment for hydride generation and cold vapour atomic absorption spectrometry. Part 2. Chemistry and application. *Analyst*, 117: 1735-1739.
- Vermeir, G., Vandecasteele, C., and Dams, R. 1989. Microwave dissolution for the determination of mercury in biological samples. *Analytica Chimica Acta*, 220: 257-261.
- Welz, B., and Melcher, M. 1984. Picotrace determination of mercury using the amalgamation technique. *Atomic Spectroscopy*, 5: 37-42.
- Welz, B., Tsalev, D., and Sperling, M. 1992. On-Line microwave sample pre-treatment for the determination of mercury in water and urine by flow-injection cold-vapour atomic absorption spectrometry. *Analytica Chimica Acta*, 261: 91-103.

Annex X:

METHOD 200.8

**DETERMINATION OF TRACE ELEMENTS IN WATERS AND WASTES
BY INDUCTIVELY COUPLED PLASMA - MASS SPECTROMETRY**

**Revision 5.4
EMMC Version**

METHOD 200.8

**DETERMINATION OF TRACE ELEMENTS IN WATERS AND WASTES
BY INDUCTIVELY COUPLED PLASMA - MASS SPECTROMETRY**

**Revision 5.4
EMMC Version**

S.E. Long (Technology Applications Inc.), T.D. Martin, and E.R. Martin - Method 200.8,
Revisions 4.2 and 4.3 (1990)

S.E. Long (Technology Applications Inc.) and T.D. Martin - Method 200.8, Revision 4.4 (1991)

J.T. Creed, C.A. Brockhoff, and T.D. Martin - Method 200.8, Revision 5.4 (1994)

**ENVIRONMENTAL MONITORING SYSTEMS LABORATORY
OFFICE OF RESEARCH AND DEVELOPMENT
U.S. ENVIRONMENTAL PROTECTION AGENCY
CINCINNATI, OHIO 45268
METHOD 200.8**

**DETERMINATION OF TRACE ELEMENTS IN WATERS AND WASTES
BY INDUCTIVELY COUPLED PLASMA - MASS SPECTROMETRY**

1.0 SCOPE AND APPLICATION

- 1.1 This method provides procedures for determination of dissolved elements in ground waters, surface waters and drinking water. It may also be used for determination of total recoverable element concentrations in these waters as well as wastewaters, sludges and soils samples. This method is applicable to the following elements:

Analyte	Chemical Abstract Services Registry Number (CASRN)	
Aluminum	(Al)	7429-90-5
Antimony	(Sb)	7440-36-0
Arsenic	(As)	7440-38-2
Barium	(Ba)	7440-39-3
Beryllium	(Be)	7440-41-7
Cadmium	(Cd)	7440-43-9
Chromium	(Cr)	7440-47-3
Cobalt	(Co)	7440-48-4
Copper	(Cu)	7440-50-8
Lead	(Pb)	7439-92-1
Manganese	(Mn)	7439-96-5
Mercury	(Hg)	7439-97-6
Molybdenum	(Mo)	7439-98-7
Nickel	(Ni)	7440-02-0
Selenium	(Se)	7782-49-2
Silver	(Ag)	7440-22-4
Thallium	(Tl)	7440-28-0
Thorium	(Th)	7440-29-1
Uranium	(U)	7440-61-1
Vanadium	(V)	7440-62-2
Zinc	(Zn)	7440-66-6

Estimated instrument detection limits (IDLs) for these elements are listed in Table 1. These are intended as a guide to instrumental limits typical of a system optimized for multielement determinations and employing commercial instrumentation and pneumatic nebulization sample introduction. However, actual method detection limits (MDLs) and linear working ranges will be dependent on the sample matrix, instrumentation and selected operating conditions. Given in Table 7 are typical MDLs for both total recoverable determinations by "direct analysis" and where sample digestion is employed.

- 1.2 For reference where this method is approved for use in compliance monitoring programs [e.g., Clean Water Act (NPDES) or Safe Drinking Water Act (SDWA)] consult both the appropriate sections of the Code of Federal Regulation (40 CFR Part 136 Table 1B for NPDES, and Part 141 § 141.23 for drinking water), and the latest Federal Register announcements.
- 1.3 Dissolved elements are determined after suitable filtration and acid preservation. In order to reduce potential interferences, dissolved solids should not exceed 0.2% (w/v) (Section 4.1.4).
- 1.4 With the exception of silver, where this method is approved for the determination of certain metal and metalloid contaminants in drinking water, samples may be analyzed directly by pneumatic nebulization without acid digestion if the samples have been properly preserved with acid and have turbidity of <1 NTU at the time of analysis. This total recoverable determination procedure is referred to as "direct analysis".
- 1.5 For the determination of total recoverable analytes in aqueous and solid samples a digestion/extraction is required prior to analysis when the elements are not in solution (e.g., soils, sludges, sediments and aqueous samples that may contain particulate and suspended solids). Aqueous samples containing suspended or particulate material $\geq 1\%$ (w/v) should be extracted as a solid type sample (Section 11.2.2).
- 1.6 The total recoverable sample digestion procedure given in this method is not suitable for the determination of volatile organo-mercury compounds. However, for "direct analysis" of drinking water (turbidity <1 NTU), the combined concentrations of inorganic and organo-mercury in solution can be determined by "direct analysis" pneumatic nebulization provided gold is added to both samples and standards alike to eliminate memory interference effects.
- 1.7 Silver is only slightly soluble in the presence of chloride unless there is a sufficient chloride concentration to form the soluble chloride complex. Therefore, low recoveries of silver may occur in samples, fortified sample matrices and even fortified blanks if determined as a dissolved analyte or by "direct analysis" where the sample has not been processed using the total recoverable mixed acid digestion. For this reason it is recommended that samples be digested prior to the determination of silver. The total recoverable sample digestion procedure given in this method is suitable for the determination of silver in aqueous samples containing concentrations up to 0.1 mg/L. For the analysis of wastewater samples containing higher concentrations of silver, succeeding smaller volume, well mixed sample aliquots must be prepared until the analysis solution contains <0.1 mg/L silver. The extraction of solid samples containing concentrations of silver >50 mg/kg should be treated in a similar manner.
- 1.8 The total recoverable sample digestion procedure given in this method will solubilize and hold in solution only minimal concentrations of barium in the presence of free sulfate. For the analysis of barium in samples having varying

and unknown concentrations of sulfate, analysis should be completed as soon as possible after sample preparation.

- 1.9 This method should be used by analysts experienced in the use of inductively coupled plasma mass spectrometry (ICP-MS), the interpretation of spectral and matrix interferences and procedures for their correction. A minimum of six months experience with commercial instrumentation is recommended.
- 1.10 Users of the method data should state the data-quality objectives prior to analysis. Users of the method must document and have on file the required initial demonstration performance data described in Section 9.2 prior to using the method for analysis.

2.0 SUMMARY OF METHOD

- 2.1 An aliquot of a well mixed, homogeneous aqueous or solid sample is accurately weighed or measured for sample processing. For total recoverable analysis of a solid or an aqueous sample containing undissolved material, analytes are first solubilized by gentle refluxing with nitric and hydrochloric acids. After cooling, the sample is made up to volume, is mixed and centrifuged or allowed to settle overnight prior to analysis. For the determination of dissolved analytes in a filtered aqueous sample aliquot, or for the "direct analysis" total recoverable determination of analytes in drinking water where sample turbidity is <1 NTU, the sample is made ready for analysis by the appropriate addition of nitric acid, and then diluted to a predetermined volume and mixed before analysis.
- 2.2 The method describes the multi-element determination of trace elements by ICP-MS.¹⁻³ Sample material in solution is introduced by pneumatic nebulization into a radiofrequency plasma where energy transfer processes cause desolvation, atomization and ionization. The ions are extracted from the plasma through a differentially pumped vacuum interface and separated on the basis of their mass-to-charge ratio by a quadrupole mass spectrometer having a minimum resolution capability of 1 amu peak width at 5% peak height. The ions transmitted through the quadrupole are detected by an electron multiplier or Faraday detector and the ion information processed by a data handling system. Interferences relating to the technique (Section 4.0) must be recognized and corrected for. Such corrections must include compensation for isobaric elemental interferences and interferences from polyatomic ions derived from the plasma gas, reagents or sample matrix. Instrumental drift as well as suppressions or enhancements of instrument response caused by the sample matrix must be corrected for by the use of internal standards.

3.0 DEFINITIONS

- 3.1 **Calibration Blank** - A volume of reagent water acidified with the same acid matrix as in the calibration standards. The calibration blank is a zero standard and is used to calibrate the ICP instrument (Section 7.6.1).

- 3.2 **Calibration Standard (CAL)** - A solution prepared from the dilution of stock standard solutions. The CAL solutions are used to calibrate the instrument response with respect to analyte concentration (Section 7.4).
- 3.3 **Dissolved Analyte** - The concentration of analyte in an aqueous sample that will pass through a 0.45 µm membrane filter assembly prior to sample acidification (Section 11.1).
- 3.4 **Field Reagent Blank (FRB)** - An aliquot of reagent water or other blank matrix that is placed in a sample container in the laboratory and treated as a sample in all respects, including shipment to the sampling site, exposure to the sampling site conditions, storage, preservation, and all analytical procedures. The purpose of the FRB is to determine if method analytes or other interferences are present in the field environment (Section 8.5).
- 3.5 **Instrument Detection Limit (IDL)** - The concentration equivalent to the analyte signal which is equal to three times the standard deviation of a series of 10 replicate measurements of the calibration blank signal at the selected analytical mass(es). (Table 1).
- 3.6 **Internal Standard** - Pure analyte(s) added to a sample, extract, or standard solution in known amount(s) and used to measure the relative responses of other method analytes that are components of the same sample or solution. The internal standard must be an analyte that is not a sample component (Sections 7.5 and 9.4.5).
- 3.7 **Laboratory Duplicates (LD1 and LD2)** - Two aliquots of the same sample taken in the laboratory and analyzed separately with identical procedures. Analyses of LD1 and LD2 indicates precision associated with laboratory procedures, but not with sample collection, preservation, or storage procedures.
- 3.8 **Laboratory Fortified Blank (LFB)** - An aliquot of LRB to which known quantities of the method analytes are added in the laboratory. The LFB is analyzed exactly like a sample, and its purpose is to determine whether the methodology is in control and whether the laboratory is capable of making accurate and precise measurements (Sections 7.9 and 9.3.2).
- 3.9 **Laboratory Fortified Sample Matrix (LFM)** - An aliquot of an environmental sample to which known quantities of the method analytes are added in the laboratory. The LFM is analyzed exactly like a sample, and its purpose is to determine whether the sample matrix contributes bias to the analytical results. The background concentrations of the analytes in the sample matrix must be determined in a separate aliquot and the measured values in the LFM corrected for background concentrations (Section 9.4).
- 3.10 **Laboratory Reagent Blank (LRB)** - An aliquot of reagent water or other blank matrices that are treated exactly as a sample including exposure to all glassware, equipment, solvents, reagents, and internal standards that are used with other samples. The LRB is used to determine if method analytes or other interferences

are present in the laboratory environment, reagents, or apparatus (Sections 7.6.2 and 9.3.1).

- 3.11 **Linear Dynamic Range (LDR)** - The concentration range over which the instrument response to an analyte is linear (Section 9.2.2).
- 3.12 **Method Detection Limit (MDL)** - The minimum concentration of an analyte that can be identified, measured, and reported with 99% confidence that the analyte concentration is greater than zero (Section 9.2.4 and Table 7).
- 3.13 **Quality Control Sample (QCS)** - A solution of method analytes of known concentrations which is used to fortify an aliquot of LRB or sample matrix. The QCS is obtained from a source external to the laboratory and different from the source of calibration standards. It is used to check either laboratory or instrument performance (Sections 7.8 and 9.2.3).
- 3.14 **Solid Sample** - For the purpose of this method, a sample taken from material classified as either soil, sediment or sludge.
- 3.15 **Stock Standard Solution** - A concentrated solution containing one or more method analytes prepared in the laboratory using assayed reference materials or purchased from a reputable commercial source (Section 7.3).
- 3.16 **Total Recoverable Analyte** - The concentration of analyte determined either by "direct analysis" of an unfiltered acid preserved drinking water sample with turbidity of <1 NTU (Section 11.2.1), or by analysis of the solution extract of a solid sample or an unfiltered aqueous sample following digestion by refluxing with hot dilute mineral acid(s) as specified in the method (Sections 11.2 and 11.3).
- 3.17 **Tuning Solution** - A solution which is used to determine acceptable instrument performance prior to calibration and sample analyses (Section 7.7).
- 3.18 **Water Sample** - For the purpose of this method, a sample taken from one of the following sources: drinking, surface, ground, storm runoff, industrial or domestic wastewater.

4.0 INTERFERENCES

- 4.1 Several interference sources may cause inaccuracies in the determination of trace elements by ICP-MS. These are:
 - 4.1.1 Isobaric elemental interferences - Are caused by isotopes of different elements which form singly or doubly charged ions of the same nominal mass-to-charge ratio and which cannot be resolved by the mass spectrometer in use. All elements determined by this method have, at a minimum, one isotope free of isobaric elemental interference. Of the analytical isotopes recommended for use with this method (Table 4), only molybdenum-98 (ruthenium) and selenium-82 (krypton) have isobaric elemental interferences. If alternative analytical isotopes having higher

natural abundance are selected in order to achieve greater sensitivity, an isobaric interference may occur. All data obtained under such conditions must be corrected by measuring the signal from another isotope of the interfering element and subtracting the appropriate signal ratio from the isotope of interest. A record of this correction process should be included with the report of the data. It should be noted that such corrections will only be as accurate as the accuracy of the isotope ratio used in the elemental equation for data calculations. Relevant isotope ratios should be established prior to the application of any corrections.

- 4.1.2 Abundance sensitivity - Is a property defining the degree to which the wings of a mass peak contribute to adjacent masses. The abundance sensitivity is affected by ion energy and quadrupole operating pressure. Wing overlap interferences may result when a small ion peak is being measured adjacent to a large one. The potential for these interferences should be recognized and the spectrometer resolution adjusted to minimize them.
- 4.1.3 Isobaric polyatomic ion interferences - Are caused by ions consisting of more than one atom which have the same nominal mass-to-charge ratio as the isotope of interest, and which cannot be resolved by the mass spectrometer in use. These ions are commonly formed in the plasma or interface system from support gases or sample components. Most of the common interferences have been identified³, and these are listed in Table 2 together with the method elements affected. Such interferences must be recognized, and when they cannot be avoided by the selection of alternative analytical isotopes, appropriate corrections must be made to the data. Equations for the correction of data should be established at the time of the analytical run sequence as the polyatomic ion interferences will be highly dependent on the sample matrix and chosen instrument conditions. In particular, the common ⁸²Kr interference that affects the determination of both arsenic and selenium, can be greatly reduced with the use of high purity krypton free argon.
- 4.1.4 Physical interferences - Are associated with the physical processes which govern the transport of sample into the plasma, sample conversion processes in the plasma, and the transmission of ions through the plasma-mass spectrometer interface. These interferences may result in differences between instrument responses for the sample and the calibration standards. Physical interferences may occur in the transfer of solution to the nebulizer (e.g., viscosity effects), at the point of aerosol formation and transport to the plasma (e.g., surface tension), or during excitation and ionization processes within the plasma itself. High levels of dissolved solids in the sample may contribute deposits of material on the extraction and/or skimmer cones reducing the effective diameter of the orifices and therefore ion transmission. Dissolved solids levels not exceeding 0.2% (w/v) have been recommended³ to reduce such effects. Internal standardization may be effectively used to compensate for many physical interference effects.⁴ Internal standards ideally should have similar

analytical behavior to the elements being determined.

- 4.1.5 Memory interferences - Result when isotopes of elements in a previous sample contribute to the signals measured in a new sample. Memory effects can result from sample deposition on the sampler and skimmer cones, and from the buildup of sample material in the plasma torch and spray chamber. The site where these effects occur is dependent on the element and can be minimized by flushing the system with a rinse blank between samples (Section 7.6.3). The possibility of memory interferences should be recognized within an analytical run and suitable rinse times should be used to reduce them. The rinse times necessary for a particular element should be estimated prior to analysis. This may be achieved by aspirating a standard containing elements corresponding to 10 times the upper end of the linear range for a normal sample analysis period, followed by analysis of the rinse blank at designated intervals. The length of time required to reduce analyte signals to within a factor of 10 of the method detection limit, should be noted. Memory interferences may also be assessed within an analytical run by using a minimum of three replicate integrations for data acquisition. If the integrated signal values drop consecutively, the analyst should be alerted to the possibility of a memory effect, and should examine the analyte concentration in the previous sample to identify if this was high. If a memory interference is suspected, the sample should be reanalyzed after a long rinse period. In the determination of mercury, which suffers from severe memory effects, the addition of 100 µg/L gold will effectively rinse 5 µg/L mercury in approximately two minutes. Higher concentrations will require a longer rinse time.

5.0 SAFETY

- 5.1 The toxicity or carcinogenicity of reagents used in this method have not been fully established. Each chemical should be regarded as a potential health hazard and exposure to these compounds should be as low as reasonably achievable. Each laboratory is responsible for maintaining a current awareness file of OSHA regulations regarding the safe handling of the chemicals specified in this method.^{5,8} A reference file of material data handling sheets should also be available to all personnel involved in the chemical analysis. Specifically, concentrated nitric and hydrochloric acids present various hazards and are moderately toxic and extremely irritating to skin and mucus membranes. Use these reagents in a fume hood whenever possible and if eye or skin contact occurs, flush with large volumes of water. Always wear safety glasses or a shield for eye protection, protective clothing and observe proper mixing when working with these reagents.
- 5.2 The acidification of samples containing reactive materials may result in the release of toxic gases, such as cyanides or sulfides. Acidification of samples should be done in a fume hood.
- 5.3 All personnel handling environmental samples known to contain or to have been

in contact with human waste should be immunized against known disease causative agents.

- 5.4 Analytical plasma sources emit radiofrequency radiation in addition to intense UV radiation. Suitable precautions should be taken to protect personnel from such hazards. The inductively coupled plasma should only be viewed with proper eye protection from UV emissions.
- 5.5 It is the responsibility of the user of this method to comply with relevant disposal and waste regulations. For guidance see Sections 14.0 and 15.0.

6.0 EQUIPMENT AND SUPPLIES

6.1 Inductively coupled plasma mass spectrometer:

- 6.1.1 Instrument capable of scanning the mass range 5-250 amu with a minimum resolution capability of 1 amu peak width at 5% peak height. Instrument may be fitted with a conventional or extended dynamic range detection system.

Note: If an electron multiplier detector is being used, precautions should be taken, where necessary, to prevent exposure to high ion flux. Otherwise changes in instrument response or damage to the multiplier may result.

- 6.1.2 Radio-frequency generator compliant with FCC regulations.
 - 6.1.3 Argon gas supply - High purity grade (99.99%). When analyses are conducted frequently, liquid argon is more economical and requires less frequent replacement of tanks than compressed argon in conventional cylinders (Section 4.1.3).
 - 6.1.4 A variable-speed peristaltic pump is required for solution delivery to the nebulizer.
 - 6.1.5 A mass-flow controller on the nebulizer gas supply is required. A water-cooled spray chamber may be of benefit in reducing some types of interferences (e.g., from polyatomic oxide species).
 - 6.1.6 If an electron multiplier detector is being used, precautions should be taken, where necessary, to prevent exposure to high ion flux. Otherwise changes in instrument response or damage to the multiplier may result. Samples having high concentrations of elements beyond the linear range of the instrument and with isotopes falling within scanning windows should be diluted prior to analysis.
- 6.2 Analytical balance, with capability to measure to 0.1 mg, for use in weighing solids, for preparing standards, and for determining dissolved solids in digests or extracts.

- 6.3 A temperature adjustable hot plate capable of maintaining a temperature of 95°C.
- 6.4 (Optional) A temperature adjustable block digester capable of maintaining a temperature of 95°C and equipped with 250 mL constricted digestion tubes.
- 6.5 (Optional) A steel cabinet centrifuge with guard bowl, electric timer and brake.
- 6.6 A gravity convection drying oven with thermostatic control capable of maintaining 105°C ± 5°C.
- 6.7 (Optional) An air displacement pipetter capable of delivering volumes ranging from 0.1-2500 µL with an assortment of high quality disposable pipet tips.
- 6.8 Mortar and pestle, ceramic or nonmetallic material.
- 6.9 Polypropylene sieve, 5-mesh (4 mm opening).
- 6.10 Labware - For determination of trace levels of elements, contamination and loss are of prime consideration. Potential contamination sources include improperly cleaned laboratory apparatus and general contamination within the laboratory environment from dust, etc. A clean laboratory work area designated for trace element sample handling must be used. Sample containers can introduce positive and negative errors in the determination of trace elements by (1) contributing contaminants through surface desorption or leaching, (2) depleting element concentrations through adsorption processes. All reusable labware (glass, quartz, polyethylene, PTFE, FEP, etc.) should be sufficiently clean for the task objectives. Several procedures found to provide clean labware include soaking overnight and thoroughly washing with laboratory-grade detergent and water, rinsing with tap water, and soaking for four hours or more in 20% (V/V) nitric acid or a mixture of dilute nitric and hydrochloric acid (1+2+9), followed by rinsing with reagent grade water and storing clean.

Note: Chromic acid must not be used for cleaning glassware.

- 6.10.1 Glassware - Volumetric flasks, graduated cylinders, funnels and centrifuge tubes (glass and/or metal free plastic).
- 6.10.2 Assorted calibrated pipettes.
- 6.10.3 Conical Phillips beakers (Corning 1080-250 or equivalent), 250 mL with 50 mm watch glasses.
- 6.10.4 Griffin beakers, 250 mL with 75 mm watch glasses and (optional) 75 mm ribbed watch glasses.
- 6.10.5 (Optional) PTFE and/or quartz beakers, 250 mL with PTFE covers.
- 6.10.6 Evaporating dishes or high-form crucibles, porcelain, 100 mL capacity.

6.10.7 Narrow-mouth storage bottles, FEP (fluorinated ethylene propylene) with ETFE (ethylene tetrafluorethylene) screw closure, 125-250 mL capacities.

6.10.8 One-piece stem FEP wash bottle with screw closure, 125 mL capacity.

7.0 REAGENTS AND STANDARDS

7.1 Reagents may contain elemental impurities that might affect the integrity of analytical data. Owing to the high sensitivity of ICP-MS, high-purity reagents should be used whenever possible. All acids used for this method must be of ultra high-purity grade. Suitable acids are available from a number of manufacturers or may be prepared by sub-boiling distillation. Nitric acid is preferred for ICP-MS in order to minimize polyatomic ion interferences. Several polyatomic ion interferences result when hydrochloric acid is used (Table 2), however, it should be noted that hydrochloric acid is required to maintain stability in solutions containing antimony and silver. When hydrochloric acid is used, corrections for the chloride polyatomic ion interferences must be applied to all data.

7.1.1 Nitric acid, concentrated (sp.gr. 1.41).

7.1.2 Nitric acid (1+1) - Add 500 mL conc. nitric acid to 400 mL of reagent grade water and dilute to 1 L.

7.1.3 Nitric acid (1+9) - Add 100 mL conc. nitric acid to 400 mL of reagent grade water and dilute to 1 L.

7.1.4 Hydrochloric acid, concentrated (sp.gr. 1.19).

7.1.5 Hydrochloric acid (1+1) - Add 500 mL conc. hydrochloric acid to 400 mL of reagent grade water and dilute to 1 L.

7.1.6 Hydrochloric acid (1+4) - Add 200 mL conc. hydrochloric acid to 400 mL of reagent grade water and dilute to 1 L.

7.1.7 Ammonium hydroxide, concentrated (sp.gr. 0.902).

7.1.8 Tartaric acid (CASRN 87-69-4).

7.2 Reagent water - All references to reagent grade water in this method refer to ASTM Type I water (ASTM D1193).⁹ Suitable water may be prepared by passing distilled water through a mixed bed of anion and cation exchange resins.

7.3 Standard Stock Solutions - Stock standards may be purchased from a reputable commercial source or prepared from ultra high-purity grade chemicals or metals (99.99-99.999% pure). All salts should be dried for one hour at 105°C, unless otherwise specified. Stock solutions should be stored in FEP bottles. Replace stock standards when succeeding dilutions for preparation of the multielement stock standards can not be verified.

CAUTION: Many metal salts are extremely toxic if inhaled or swallowed. Wash hands thoroughly after handling.

The following procedures may be used for preparing standard stock solutions:

Note: Some metals, particularly those which form surface oxides require cleaning prior to being weighed. This may be achieved by pickling the surface of the metal in acid. An amount in excess of the desired weight should be pickled repeatedly, rinsed with water, dried and weighed until the desired weight is achieved.

- 7.3.1 Aluminum solution, stock 1 mL = 1000 µg Al: Pickle aluminum metal in warm (1+1) HCl to an exact weight of 0.100 g. Dissolve in 10 mL conc. HCl and 2 mL conc. nitric acid, heating to effect solution. Continue heating until volume is reduced to 4 mL. Cool and add 4 mL reagent grade water. Heat until the volume is reduced to 2 mL. Cool and dilute to 100 mL with reagent grade water.
- 7.3.2 Antimony solution, stock 1 mL = 1000 µg Sb: Dissolve 0.100 g antimony powder in 2 mL (1+1) nitric acid and 0.5 mL conc. hydrochloric acid, heating to effect solution. Cool, add 20 mL reagent grade water and 0.15 g tartaric acid. Warm the solution to dissolve the white precipitate. Cool and dilute to 100 mL with reagent grade water.
- 7.3.3 Arsenic solution, stock 1 mL = 1000 µg As: Dissolve 0.1320 g As₂O₃ in a mixture of 50 mL reagent grade water and 1 mL conc. ammonium hydroxide. Heat gently to dissolve. Cool and acidify the solution with 2 mL conc. nitric acid. Dilute to 100 mL with reagent grade water.
- 7.3.4 Barium solution, stock 1 mL = 1000 µg Ba: Dissolve 0.1437 g BaCO₃ in a solution mixture of 10 mL reagent grade water and 2 mL conc. nitric acid. Heat and stir to effect solution and degassing. Dilute to 100 mL with reagent grade water.
- 7.3.5 Beryllium solution, stock 1 mL = 1000 µg Be: Dissolve 1.965 g BeSO₄•4H₂O (DO NOT DRY) in 50 mL reagent grade water. Add 1 mL conc. nitric acid. Dilute to 100 mL with reagent grade water.
- 7.3.6 Bismuth solution, stock 1 mL = 1000 µg Bi: Dissolve 0.1115 g Bi₂O₃ in 5 mL conc. nitric acid. Heat to effect solution. Cool and dilute to 100 mL with reagent grade water.
- 7.3.7 Cadmium solution, stock 1 mL = 1000 µg Cd: Pickle cadmium metal in (1+9) nitric acid to an exact weight of 0.100 g. Dissolve in 5 mL (1+1) nitric acid, heating to effect solution. Cool and dilute to 100 mL with reagent grade water.
- 7.3.8 Chromium solution, stock 1 mL = 1000 µg Cr: Dissolve 0.1923 g CrO₃ in a solution mixture of 10 mL reagent grade water and 1 mL conc. nitric

acid. Dilute to 100 mL with reagent grade water.

- 7.3.9 Cobalt solution, stock 1 mL = 1000 µg Co: Pickle cobalt metal in (1+9) nitric acid to an exact weight of 0.100 g. Dissolve in 5 mL (1+1) nitric acid, heating to effect solution. Cool and dilute to 100 mL with reagent grade water.
- 7.3.10 Copper solution, stock 1 mL = 1000 µg Cu: Pickle copper metal in (1+9) nitric acid to an exact weight of 0.100 g. Dissolve in 5 mL (1+1) nitric acid, heating to effect solution. Cool and dilute to 100 mL with reagent grade water.
- 7.3.11 Gold solution, stock 1 mL = 1000 µg Au: Dissolve 0.100 g high purity (99.9999%) Au shot in 10 mL of hot conc. nitric acid by dropwise addition of 5 mL conc. HCl and then reflux to expel oxides of nitrogen and chlorine. Cool and dilute to 100 mL with reagent grade water.
- 7.3.12 Indium solution, stock 1 mL = 1000 µg In: Pickle indium metal in (1+1) nitric acid to an exact weight of 0.100 g. Dissolve in 10 mL (1+1) nitric acid, heating to effect solution. Cool and dilute to 100 mL with reagent grade water.
- 7.3.13 Lead solution, stock 1 mL = 1000 µg Pb: Dissolve 0.1599 g PbNO₃ in 5 mL (1+1) nitric acid. Dilute to 100 mL with reagent grade water.
- 7.3.14 Magnesium solution, stock 1 mL = 1000 µg Mg: Dissolve 0.1658 g MgO in 10 mL (1+1) nitric acid, heating to effect solution. Cool and dilute to 100 mL with reagent grade water.
- 7.3.15 Manganese solution, stock 1 mL = 1000 µg Mn: Pickle manganese flake in (1+9) nitric acid to an exact weight of 0.100 g. Dissolve in 5 mL (1+1) nitric acid, heating to effect solution. Cool and dilute to 100 mL with reagent grade water.
- 7.3.16 Mercury solution, stock, 1 mL = 1000 µg Hg: **DO NOT DRY. CAUTION:** highly toxic element. Dissolve 0.1354 g HgCl₂ in reagent water. Add 5.0 mL concentrated HNO₃ and dilute to 100 mL with reagent water.
- 7.3.17 Molybdenum solution, stock 1 mL = 1000 µg Mo: Dissolve 0.1500 g MoO₃ in a solution mixture of 10 mL reagent grade water and 1 mL conc. ammonium hydroxide., heating to effect solution. Cool and dilute to 100 mL with reagent grade water.
- 7.3.18 Nickel solution, stock 1 mL = 1000 µg Ni: Dissolve 0.100 g nickel powder in 5 mL conc. nitric acid, heating to effect solution. Cool and dilute to 100 mL with reagent grade water.
- 7.3.19 Scandium solution, stock 1 mL = 1000 µg Sc: Dissolve 0.1534 g Sc₂O₃ in 5 mL (1+1) nitric acid, heating to effect solution. Cool and dilute to

100 mL with reagent grade water.

- 7.3.20 Selenium solution, stock 1 mL = 1000 µg Se: Dissolve 0.1405 g SeO_2 in 20 mL ASTM Type I water. Dilute to 100 mL with reagent grade water.
- 7.3.21 Silver solution, stock 1 mL = 1000 µg Ag: Dissolve 0.100 g silver metal in 5 mL (1+1) nitric acid, heating to effect solution. Cool and dilute to 100 mL with reagent grade water. Store in dark container.
- 7.3.22 Terbium solution, stock 1 mL = 1000 µg Tb: Dissolve 0.1176 g Tb_4O_7 in 5 mL conc. nitric acid, heating to effect solution. Cool and dilute to 100 mL with reagent grade water.
- 7.3.23 Thallium solution, stock 1 mL = 1000 µg Tl: Dissolve 0.1303 g TlNO_3 in a solution mixture of 10 mL reagent grade water and 1 mL conc. nitric acid. Dilute to 100 mL with reagent grade water.
- 7.3.24 Thorium solution, stock 1 mL = 1000 µg Th: Dissolve 0.2380 g $\text{Th}(\text{NO}_3)_4 \cdot 4\text{H}_2\text{O}$ (DO NOT DRY) in 20 mL reagent grade water. Dilute to 100 mL with reagent grade water.
- 7.3.25 Uranium solution, stock 1 mL = 1000 µg U: Dissolve 0.2110 g $\text{UO}_2(\text{NO}_3)_2 \cdot 6\text{H}_2\text{O}$ (DO NOT DRY) in 20 mL reagent grade water and dilute to 100 mL with reagent grade water.
- 7.3.26 Vanadium solution, stock 1 mL = 1000 µg V: Pickle vanadium metal in (1+9) nitric acid to an exact weight of 0.100 g. Dissolve in 5 mL (1+1) nitric acid, heating to effect solution. Cool and dilute to 100 mL with reagent grade water.
- 7.3.27 Yttrium solution, stock 1 mL = 1000 µg Y: Dissolve 0.1270 g Y_2O_3 in 5 mL (1+1) nitric acid, heating to effect solution. Cool and dilute to 100 mL with reagent grade water.
- 7.3.28 Zinc solution, stock 1 mL = 1000 µg Zn: Pickle zinc metal in (1+9) nitric acid to an exact weight of 0.100 g. Dissolve in 5 mL (1+1) nitric acid, heating to effect solution. Cool and dilute to 100 mL with reagent grade water.
- 7.4 Multielement Stock Standard Solutions - Care must be taken in the preparation of multielement stock standards that the elements are compatible and stable. Originating element stocks should be checked for the presence of impurities which might influence the accuracy of the standard. Freshly prepared standards should be transferred to acid cleaned, not previously used FEP fluorocarbon bottles for storage and monitored periodically for stability. The following combinations of elements are suggested:

Standard Solution A		Standard Solution B
Aluminum	Mercury	Barium
Antimony	Molybdenum	Silver
Arsenic	Nickel	
Beryllium	Selenium	
Cadmium	Thallium	
Chromium	Thorium	
Cobalt	Uranium	
Copper	Vanadium	
Lead	Zinc	
Manganese		

Except for selenium and mercury, multielement stock standard solutions A and B (1 mL = 10 µg) may be prepared by diluting 1.0 mL of each single element stock standard in the combination list to 100 mL with reagent water containing 1% (v/v) nitric acid. For mercury and selenium in solution A, aliquots of 0.05 mL and 5.0 mL of the respective stock standards should be diluted to the specified 100 mL (1 mL = 0.5 µg Hg and 50 µg Se). Replace the multielement stock standards when succeeding dilutions for preparation of the calibration standards cannot be verified with the quality control sample.

7.4.1 Preparation of calibration standards - fresh multielement calibration standards should be prepared every two weeks or as needed. Dilute each of the stock multielement standard solutions A and B to levels appropriate to the operating range of the instrument using reagent water containing 1% (v/v) nitric acid. The element concentrations in the standards should be sufficiently high to produce good measurement precision and to accurately define the slope of the response curve. Depending on the sensitivity of the instrument, concentrations ranging from 10-200 µg/L are suggested, except mercury, which should be limited to ≤5 µg/L. It should be noted the selenium concentration is always a factor of 5 greater than the other analytes. If the direct addition procedure is being used (Method A, Section 10.3), add internal standards (Section 7.5) to the calibration standards and store in FEP bottles. Calibration standards should be verified initially using a quality control sample (Section 7.8).

7.5 Internal Standards Stock Solution - 1 mL = 100 µg. Dilute 10 mL of scandium, yttrium, indium, terbium and bismuth stock standards (Section 7.3) to 100 mL with reagent water, and store in a FEP bottle. Use this solution concentrate for addition to blanks, calibration standards and samples, or dilute by an appropriate amount using 1% (v/v) nitric acid, if the internal standards are being added by peristaltic pump (Method B, Section 10.3).

Note: If mercury is to be determined by the "direct analysis" procedure, add an aliquot of the gold stock standard (Section 7.3.11) to the internal standard solution sufficient to provide a concentration of 100 µg/L in final the dilution of all blanks, calibration standards, and samples.

- 7.6 Blanks - Three types of blanks are required for this method. A calibration blank is used to establish the analytical calibration curve, the laboratory reagent blank is used to assess possible contamination from the sample preparation procedure and to assess spectral background and the rinse blank is used to flush the instrument between samples in order to reduce memory interferences.
- 7.6.1 Calibration blank - Consists of 1% (v/v) nitric acid in reagent grade water. If the direct addition procedure (Method A, Section 10.3) is being used, add internal standards.
- 7.6.2 Laboratory reagent blank (LRB) - Must contain all the reagents in the same volumes as used in processing the samples. The LRB must be carried through the same entire preparation scheme as the samples including digestion, when applicable. If the direct addition procedure (Method A, Section 10.3) is being used, add internal standards to the solution after preparation is complete.
- 7.6.3 Rinse blank - Consists of 2% (v/v) nitric acid in reagent grade water.
- Note:** If mercury is to be determined by the "direct analysis" procedure, add gold (Section 7.3.11) to the rinse blank to a concentration of 100 µg/L.
- 7.7 Tuning Solution - This solution is used for instrument tuning and mass calibration prior to analysis. The solution is prepared by mixing beryllium, magnesium, cobalt, indium and lead stock solutions (Section 7.3) in 1% (v/v) nitric acid to produce a concentration of 100 µg/L of each element. Internal standards are not added to this solution. (Depending on the sensitivity of the instrument, this solution may need to be diluted 10-fold.)
- 7.8 Quality Control Sample (QCS) - The QCS should be obtained from a source outside the laboratory. The concentration of the QCS solution analyzed will depend on the sensitivity of the instrument. To prepare the QCS dilute an appropriate aliquot of analytes to a concentration ≤100 µg/L in 1% (v/v) nitric acid. Because of lower sensitivity, selenium may be diluted to a concentration of <500 µg/L, however, in all cases, mercury should be limited to a concentration of ≤5 µg/L. If the direct addition procedure (Method A, Section 10.3) is being used, add internal standards after dilution, mix and store in a FEP bottle. The QCS should be analyzed as needed to meet data-quality needs and a fresh solution should be prepared quarterly or more frequently as needed.
- 7.9 Laboratory Fortified Blank (LFB) - To an aliquot of LRB, add aliquots from multielement stock standards A and B (Section 7.4) to prepared the LFB. Depending on the sensitivity of the instrument, the fortified concentration used should range from 40-100 µg/L for each analyte, except selenium and mercury. For selenium the concentration should range from 200-500 µg/L, while the concentration range mercury should be limited to 2-5 µg/L. The LFB must be carried through the same entire preparation scheme as the samples including sample digestion, when applicable. If the direct addition procedure (Method A, Section 10.3) is being used, add internal standards to this solution after

preparation has been completed.

8.0 SAMPLE COLLECTION, PRESERVATION, AND STORAGE

- 8.1 Prior to the collection of an aqueous sample, consideration should be given to the type of data required, (i.e., dissolved or total recoverable), so that appropriate preservation and pretreatment steps can be taken. The pH of all aqueous samples **must** be tested immediately prior to aliquoting for processing or "direct analysis" to ensure the sample has been properly preserved. If properly acid preserved, the sample can be held up to 6 months before analysis.
- 8.2 For the determination of dissolved elements, the sample must be filtered through a 0.45 μm pore diameter membrane filter at the time of collection or as soon thereafter as practically possible. Use a portion of the sample to rinse the filter flask, discard this portion and collect the required volume of filtrate. Acidify the filtrate with (1+1) nitric acid immediately following filtration to pH <2.
- 8.3 For the determination of total recoverable elements in aqueous samples, samples are **not** filtered, but acidified with (1+1) nitric acid to pH <2 (normally, 3 mL of (1+1) acid per liter of sample is sufficient for most ambient and drinking water samples). Preservation may be done at the time of collection, however, to avoid the hazards of strong acids in the field, transport restrictions, and possible contamination it is recommended that the samples be returned to the laboratory within two weeks of collection and acid preserved upon receipt in the laboratory. Following acidification, the sample should be mixed, held for 16 hours, and then verified to be pH <2 just prior withdrawing an aliquot for processing or "direct analysis". If for some reason such as high alkalinity the sample pH is verified to be >2, more acid must be added and the sample held for 16 hours until verified to be pH <2. See Section 8.1.
- Note:** When the nature of the sample is either unknown or known to be hazardous, acidification should be done in a fume hood. See Section 5.2.
- 8.4 Solid samples require no preservation prior to analysis other than storage at 4°C. There is no established holding time limitation for solid samples.
- 8.5 For aqueous samples, a field blank should be prepared and analyzed as required by the data user. Use the same container and acid as used in sample collection.

9.0 QUALITY CONTROL

- 9.1 Each laboratory using this method is required to operate a formal quality control (QC) program. The minimum requirements of this program consist of an initial demonstration of laboratory capability, and the periodic analysis of laboratory reagent blanks, fortified blanks and calibration solutions as a continuing check on performance. The laboratory is required to maintain performance records that define the quality of the data thus generated.
- 9.2 Initial Demonstration of Performance (mandatory)

- 9.2.1 The initial demonstration of performance is used to characterize instrument performance (determination of linear calibration ranges and analysis of quality control samples) and laboratory performance (determination of method detection limits) prior to analyses conducted by this method.
- 9.2.2 Linear calibration ranges - Linear calibration ranges are primarily detector limited. The upper limit of the linear calibration range should be established for each analyte by determining the signal responses from a minimum of three different concentration standards, one of which is close to the upper limit of the linear range. Care should be taken to avoid potential damage to the detector during this process. The linear calibration range which may be used for the analysis of samples should be judged by the analyst from the resulting data. The upper LDR limit should be an observed signal no more than 10% below the level extrapolated from lower standards. Determined sample analyte concentrations that are greater than 90% of the determined upper LDR limit must be diluted and reanalyzed. The LDRs should be verified whenever, in the judgement of the analyst, a change in analytical performance caused by either a change in instrument hardware or operating conditions would dictate they be redetermined.
- 9.2.3 Quality control sample (QCS) - When beginning the use of this method, on a quarterly basis or as required to meet data-quality needs, verify the calibration standards and acceptable instrument performance with the preparation and analyses of a QCS (Section 7.8). To verify the calibration standards the determined mean concentration from three analyses of the QCS must be within $\pm 10\%$ of the stated QCS value. If the QCS is used for determining acceptable on-going instrument performance, analysis of the QCS prepared to a concentration of 100 $\mu\text{g/L}$ must be within $\pm 10\%$ of the stated value or within the acceptance limits listed in Table 8, whichever is the greater. (If the QCS is not within the required limits, an immediate second analysis of the QCS is recommended to confirm unacceptable performance.) If the calibration standards and/or acceptable instrument performance cannot be verified, the source of the problem must be identified and corrected before either proceeding on with the initial determination of method detection limits or continuing with on-going analyses.
- 9.2.4 Method detection limits (MDL) should be established for all analytes, using reagent water (blank) fortified at a concentration of two to five times the estimated detection limit.⁷ To determine MDL values, take seven replicate aliquots of the fortified reagent water and process through the entire analytical method. Perform all calculations defined in the method and report the concentration values in the appropriate units. Calculate the MDL as follows:

$$\text{MDL} = (t) \times (S)$$

where:

t = Student's t value for a 99% confidence level and a standard deviation estimate with n-1 degrees of freedom [t = 3.14 for seven replicates]

S = standard deviation of the replicate analyses

Note: If additional confirmation is desired, reanalyze the seven replicate aliquots on two more nonconsecutive days and again calculate the MDL values for each day. An average of the three MDL values for each analyte may provide for a more appropriate MDL estimate. If the relative standard deviation (RSD) from the analyses of the seven aliquots is <10%, the concentration used to determine the analyte MDL may have been inappropriately high for the determination. If so, this could result in the calculation of an unrealistically low MDL. Concurrently, determination of MDL in reagent water represents a best case situation and does not reflect possible matrix effects of real world samples. However, successful analyses of LFMs (Section 9.4) can give confidence to the MDL value determined in reagent water. Typical single laboratory MDL values using this method are given in Table 7.

The MDLs must be sufficient to detect analytes at the required levels according to compliance monitoring regulation (Section 1.2). MDLs should be determined annually, when a new operator begins work or whenever, in the judgement of the analyst, a change in analytical performance caused by either a change in instrument hardware or operating conditions would dictate they be redetermined.

9.3 Assessing Laboratory Performance (mandatory)

9.3.1 Laboratory reagent blank (LRB) - The laboratory must analyze at least one LRB (Section 7.6.2) with each batch of 20 or fewer of samples of the same matrix. LRB data are used to assess contamination from the laboratory environment and to characterize spectral background from the reagents used in sample processing. LRB values that exceed the MDL indicate laboratory or reagent contamination should be suspected. When LRB values constitute 10% or more of the analyte level determined for a sample or is 2.2 times the analyte MDL whichever is greater, fresh aliquots of the samples must be prepared and analyzed again for the affected analytes after the source of contamination has been corrected and acceptable LRB values have been obtained.

9.3.2 Laboratory fortified blank (LFB) - The laboratory must analyze at least one LFB (Section 7.9) with each batch of samples. Calculate accuracy as percent recovery using the following equation:

$$R = \frac{\text{LFB} - \text{LRB}}{s} \times 100$$

where:

- R = percent recovery
- LFB = laboratory fortified blank
- LRB = laboratory reagent blank
- s = concentration equivalent of analyte added to fortify the LBR solution

If the recovery of any analyte falls outside the required control limits of 85-115%, that analyte is judged out of control, and the source of the problem should be identified and resolved before continuing analyses.

- 9.3.3 The laboratory must use LFB analyses data to assess laboratory performance against the required control limits of 85-115% (Section 9.3.2). When sufficient internal performance data become available (usually a minimum of 20-30 analyses), optional control limits can be developed from the mean percent recovery (\bar{x}) and the standard deviation (S) of the mean percent recovery. These data can be used to establish the upper and lower control limits as follows:

$$\begin{aligned}\text{UPPER CONTROL LIMIT} &= \bar{x} + 3S \\ \text{LOWER CONTROL LIMIT} &= \bar{x} - 3S\end{aligned}$$

The optional control limits must be equal to or better than the required control limits of 85-115%. After each five to ten new recovery measurements, new control limits can be calculated using only the most recent 20-30 data points. Also, the standard deviation (S) data should be used to establish an on-going precision statement for the level of concentrations included in the LFB. These data must be kept on file and be available for review.

- 9.3.4 Instrument performance - For all determinations the laboratory must check instrument performance and verify that the instrument is properly calibrated on a continuing basis. To verify calibration run the calibration blank and calibration standards as surrogate samples immediately following each calibration routine, after every ten analyses and at the end of the sample run. The results of the analyses of the standards will indicate whether the calibration remains valid. The analysis of all analytes within the standard solutions must be within $\pm 10\%$ of calibration. If the calibration cannot be verified within the specified limits, the instrument must be recalibrated. (The instrument responses from the calibration check may be used for recalibration purposes, however, it must be verified before continuing sample analysis.) If the continuing calibration check is not confirmed within $\pm 15\%$, the previous 10 samples must be reanalyzed after recalibration. If the sample matrix is responsible for the calibration drift, it is recommended that the previous 10 samples are reanalyzed in groups of five between calibration checks to prevent a similar drift situation from occurring.

9.4 Assessing Analyte Recovery and Data Quality

- 9.4.1 Sample homogeneity and the chemical nature of the sample matrix can affect analyte recovery and the quality of the data. Taking separate aliquots from the sample for replicate and fortified analyses can in some cases assess the effect. Unless otherwise specified by the data user, laboratory or program, the following laboratory fortified matrix (LFM) procedure (Section 9.4.2) is required.
- 9.4.2 The laboratory must add a known amount of analyte to a minimum of 10% of the routine samples. In each case the LFM aliquot must be a duplicate of the aliquot used for sample analysis and for total recoverable determinations added prior to sample preparation. For water samples, the added analyte concentration must be the same as that used in the laboratory fortified blank (Section 7.9). For solid samples, the concentration added should be 100 mg/kg equivalent (200 µg/L in the analysis solution) except silver which should be limited to 50 mg/kg (Section 1.8). Over time, samples from all routine sample sources should be fortified.
- 9.4.3 Calculate the percent recovery for each analyte, corrected for background concentrations measured in the unfortified sample, and compare these values to the designated LFM recovery range of 70-130%. Recovery calculations are not required if the concentration of the analyte added is less than 30% of the sample background concentration. Percent recovery may be calculated in units appropriate to the matrix, using the following equation:

$$R = \frac{C_s - C}{s} \times 100$$

where:

R = percent recovery

C_s = fortified sample concentration

C = sample background concentration

s = concentration equivalent of analyte added to fortify the sample

- 9.4.4 If recovery of any analyte falls outside the designated range and laboratory performance for that analyte is shown to be in control (Section 9.3), the recovery problem encountered with the fortified sample is judged to be matrix related, not system related. The data user should be informed that the result for that analyte in the unfortified sample is suspect due to either the heterogeneous nature of the sample or an uncorrected matrix effect.
- 9.4.5 Internal standards responses - The analyst is expected to monitor the responses from the internal standards throughout the sample set being

analyzed. Ratios of the internal standards responses against each other should also be monitored routinely. This information may be used to detect potential problems caused by mass dependent drift, errors incurred in adding the internal standards or increases in the concentrations of individual internal standards caused by background contributions from the sample. The absolute response of any one internal standard must not deviate more than 60-125% of the original response in the calibration blank. If deviations greater than these are observed, flush the instrument with the rinse blank and monitor the responses in the calibration blank. If the responses of the internal standards are now within the limit, take a fresh aliquot of the sample, dilute by a further factor of two, add the internal standards and reanalyze. If after flushing the response of the internal standards in the calibration blank are out of limits, terminate the analysis and determine the cause of the drift. Possible causes of drift may be a partially blocked sampling cone or a change in the tuning condition of the instrument.

10.0 CALIBRATION AND STANDARDIZATION

- 10.1 Operating conditions - Because of the diversity of instrument hardware, no detailed instrument operating conditions are provided. The analyst is advised to follow the recommended operating conditions provided by the manufacturer. It is the responsibility of the analyst to verify that the instrument configuration and operating conditions satisfy the analytical requirements and to maintain quality control data verifying instrument performance and analytical results. Instrument operating conditions which were used to generate precision and recovery data for this method (Section 13.0) are included in Table 6.
- 10.2 Precalibration routine - The following precalibration routine must be completed prior to calibrating the instrument until such time it can be documented with periodic performance data that the instrument meets the criteria listed below without daily tuning.
- 10.2.1 Initiate proper operating configuration of instrument and data system. Allow a period of not less than 30 minutes for the instrument to warm up. During this process conduct mass calibration and resolution checks using the tuning solution. Resolution at low mass is indicated by magnesium isotopes 24, 25, and 26. Resolution at high mass is indicated by lead isotopes 206, 207, and 208. For good performance adjust spectrometer resolution to produce a peak width of approximately 0.75 amu at 5% peak height. Adjust mass calibration if it has shifted by more than 0.1 amu from unit mass.
- 10.2.2 Instrument stability must be demonstrated by running the tuning solution (Section 7.7) a minimum of five times with resulting relative standard deviations of absolute signals for all analytes of less than 5%.
- 10.3 Internal Standardization - Internal standardization must be used in all analyses to correct for instrument drift and physical interferences. A list of acceptable

internal standards is provided in Table 3. For full mass range scans, a minimum of three internal standards must be used. Procedures described in this method for general application, detail the use of five internal standards; scandium, yttrium, indium, terbium and bismuth. These were used to generate the precision and recovery data attached to this method. Internal standards must be present in all samples, standards and blanks at identical levels. This may be achieved by directly adding an aliquot of the internal standards to the CAL standard, blank or sample solution (Method A, Section 10.3), or alternatively by mixing with the solution prior to nebulization using a second channel of the peristaltic pump and a mixing coil (Method B, Section 10.3). The concentration of the internal standard should be sufficiently high that good precision is obtained in the measurement of the isotope used for data correction and to minimize the possibility of correction errors if the internal standard is naturally present in the sample. Depending on the sensitivity of the instrument, a concentration range of 20-200 µg/L of each internal standard is recommended. Internal standards should be added to blanks, samples and standards in a like manner, so that dilution effects resulting from the addition may be disregarded.

- 10.4 Calibration - Prior to initial calibration, set up proper instrument software routines for quantitative analysis. The instrument must be calibrated using one of the internal standard routines (Method A or B) described in Section 10.3. The instrument must be calibrated for the analytes to be determined using the calibration blank (Section 7.6.1) and calibration standards A and B (Section 7.4.1) prepared at one or more concentration levels. A minimum of three replicate integrations are required for data acquisition. Use the average of the integrations for instrument calibration and data reporting.
- 10.5 The rinse blank should be used to flush the system between solution changes for blanks, standards and samples. Allow sufficient rinse time to remove traces of the previous sample (Section 4.1.5). Solutions should be aspirated for 30 seconds prior to the acquisition of data to allow equilibrium to be established.

11.0 PROCEDURE

11.1 Aqueous Sample Preparation - Dissolved Analytes

11.1.1 For the determination of dissolved analytes in ground and surface waters, pipet an aliquot (≥ 20 mL) of the filtered, acid preserved sample into a 50 mL polypropylene centrifuge tube. Add an appropriate volume of (1+1) nitric acid to adjust the acid concentration of the aliquot to approximate a 1% (v/v) nitric acid solution (e.g., add 0.4 mL (1+1) HNO₃ to a 20 mL aliquot of sample). If the direct addition procedure (Method A, Section 10.3) is being used, add internal standards, cap the tube and mix. The sample is now ready for analysis (Section 1.2). Allowance for sample dilution should be made in the calculations.

Note: If a precipitate is formed during acidification, transport, or storage, the sample aliquot must be treated using the procedure in Section 11.2 prior to analysis.

11.2 Aqueous Sample Preparation - Total Recoverable Analytes

11.2.1 For the "direct analysis" of total recoverable analytes in drinking water samples containing turbidity <1 NTU, treat an unfiltered acid preserved sample aliquot using the sample preparation procedure described in Section 11.1.1 while making allowance for sample dilution in the data calculation. For the determination of total recoverable analytes in all other aqueous samples or for preconcentrating drinking water samples prior to analysis follow the procedure given in Sections 11.2.2 through 11.2.8.

11.2.2 For the determination of total recoverable analytes in aqueous samples (other than drinking water with <1 NTU turbidity), transfer a 100 mL (± 1 mL) aliquot from a well mixed, acid preserved sample to a 250 mL Griffin beaker (Sections 1.2, 1.3, 1.7, and 1.8). (When necessary, smaller sample aliquot volumes may be used.)

Note: If the sample contains undissolved solids >1%, a well mixed, acid preserved aliquot containing no more than 1 g particulate material should be cautiously evaporated to near 10 mL and extracted using the acid-mixture procedure described in Sections 11.3.3 through 11.3.7.

11.2.3 Add 2 mL (1+1) nitric acid and 1.0 mL of (1+1) hydrochloric acid to the beaker containing the measured volume of sample. Place the beaker on the hot plate for solution evaporation. The hot plate should be located in a fume hood and previously adjusted to provide evaporation at a temperature of approximately but no higher than 85°C. (See the following note.) The beaker should be covered with an elevated watch glass or other necessary steps should be taken to prevent sample contamination from the fume hood environment.

Note: For proper heating adjust the temperature control of the hot plate such that an uncovered Griffin beaker containing 50 mL of water placed in the center of the hot plate can be maintained at a temperature approximately but no higher than 85°C. (Once the beaker is covered with a watch glass the temperature of the water will rise to approximately 95°C.)

11.2.4 Reduce the volume of the sample aliquot to about 20 mL by gentle heating at 85°C. DO NOT BOIL. This step takes about two hours for a 100 mL aliquot with the rate of evaporation rapidly increasing as the sample volume approaches 20 mL. (A spare beaker containing 20 mL of water can be used as a gauge.)

11.2.5 Cover the lip of the beaker with a watch glass to reduce additional evaporation and gently reflux the sample for 30 minutes. (Slight boiling may occur, but vigorous boiling must be avoided to prevent loss of the HCl-H₂O azeotrope.)

11.2.6 Allow the beaker to cool. Quantitatively transfer the sample solution to

a 50 mL volumetric flask or 50 mL class A stoppered graduated cylinder, make to volume with reagent water, stopper and mix.

- 11.2.7 Allow any undissolved material to settle overnight, or centrifuge a portion of the prepared sample until clear. (If after centrifuging or standing overnight the sample contains suspended solids that would clog the nebulizer, a portion of the sample may be filtered for their removal prior to analysis. However, care should be exercised to avoid potential contamination from filtration.)
- 11.2.8 Prior to analysis, adjust the chloride concentration by pipetting 20 mL of the prepared solution into a 50 mL volumetric flask, dilute to volume with reagent water and mix. (If the dissolved solids in this solution are >0.2%, additional dilution may be required to prevent clogging of the extraction and/or skimmer cones. If the direct addition procedure (Method A, Section 10.3) is being used, add internal standards and mix. The sample is now ready for analysis. Because the effects of various matrices on the stability of diluted samples cannot be characterized, all analyses should be performed as soon as possible after the completed preparation.

11.3 Solid Sample Preparation - Total Recoverable Analytes

- 11.3.1 For the determination of total recoverable analytes in solid samples, mix the sample thoroughly and transfer a portion (>20 g) to tared weighing dish, weigh the sample and record the wet weight (WW). (For samples with <35% moisture a 20 g portion is sufficient. For samples with moisture >35% a larger aliquot 50-100 g is required.) Dry the sample to a constant weight at 60°C and record the dry weight (DW) for calculation of percent solids (Section 12.6). (The sample is dried at 60°C to prevent the loss of mercury and other possible volatile metallic compounds, to facilitate sieving, and to ready the sample for grinding.)
- 11.3.2 To achieve homogeneity, sieve the dried sample using a 5-mesh polypropylene sieve and grind in a mortar and pestle. (The sieve, mortar and pestle should be cleaned between samples.) From the dried, ground material weigh accurately a representative 1.0 ± 0.01 g aliquot (W) of the sample and transfer to a 250 mL Phillips beaker for acid extraction.
- 11.3.3 To the beaker add 4 mL of (1+1) HNO₃ and 10 mL of (1+4) HCl. Cover the lip of the beaker with a watch glass. Place the beaker on a hot plate for reflux extraction of the analytes. The hot plate should be located in a fume hood and previously adjusted to provide a reflux temperature of approximately 95°C. (See the following note.)

Note: For proper heating adjust the temperature control of the hot plate such that an uncovered Griffin beaker containing 50 mL of water placed in the center of the hot plate can be maintained at a temperature approximately but no higher than 85°C. (Once the beaker is covered with a watch glass the temperature of the water will rise to approximately

95°C.) Also, a block digester capable of maintaining a temperature of 95°C and equipped with 250 mL constricted volumetric digestion tubes may be substituted for the hot plate and conical beakers in the extraction step.

- 11.3.4 Heat the sample and gently reflux for 30 minutes. Very slight boiling may occur, however vigorous boiling must be avoided to prevent loss of the HCl-H₂O azeotrope. Some solution evaporation will occur (3-4 mL).
- 11.3.5 Allow the sample to cool and quantitatively transfer the extract to a 100 mL volumetric flask. Dilute to volume with reagent water, stopper and mix.
- 11.3.6 Allow the sample extract solution to stand overnight to separate insoluble material or centrifuge a portion of the sample solution until clear. (If after centrifuging or standing overnight the extract solution contains suspended solids that would clog the nebulizer, a portion of the extract solution may be filtered for their removal prior to analysis. However, care should be exercised to avoid potential contamination from filtration.)
- 11.3.7 Prior to analysis, adjust the chloride concentration by pipetting 20 mL of the prepared solution into a 100 mL volumetric flask, dilute to volume with reagent water and mix. (If the dissolved solids in this solution are >0.2%, additional dilution may be required to prevent clogging of the extraction and/or skimmer cones. If the direct addition procedure (Method A, Section 10.3) is being used, add internal standards and mix. The sample extract is now ready for analysis. Because the effects of various matrices on the stability of diluted samples cannot be characterized, all analyses should be performed as soon as possible after the completed preparation.

Note: Determine the percent solids in the sample for use in calculations and for reporting data on a dry weight basis.

11.4 Sample Analysis

- 11.4.1 For every new or unusual matrix, it is highly recommended that a semi-quantitative analysis be carried out to screen the sample for elements at high concentration. Information gained from this may be used to prevent potential damage to the detector during sample analysis and to identify elements which may be higher than the linear range. Matrix screening may be carried out by using intelligent software, if available, or by diluting the sample by a factor of 500 and analyzing in a semi-quantitative mode. The sample should also be screened for background levels of all elements chosen for use as internal standards in order to prevent bias in the calculation of the analytical data.
- 11.4.2 Initiate instrument operating configuration. Tune and calibrate the instrument for the analytes of interest (Section 10.0).

- 11.4.3 Establish instrument software run procedures for quantitative analysis. For all sample analyses, a minimum of three replicate integrations are required for data acquisition. Use the average of the integrations for data reporting.
- 11.4.4 All masses which might affect data quality must be monitored during the analytical run. As a minimum, those masses prescribed in Table 4 must be monitored in the same scan as is used for the collection of the data. This information should be used to correct the data for identified interferences.
- 11.4.5 During the analysis of samples, the laboratory must comply with the required quality control described in Sections 9.3 and 9.4. Only for the determination of dissolved analytes or the "direct analysis" of drinking water with turbidity of <1 NTU is the sample digestion step of the LRB, LFB, and LFM not required.
- 11.4.6 The rinse blank should be used to flush the system between samples. Allow sufficient time to remove traces of the previous sample or a minimum of one minute (Section 4.1.5). Samples should be aspirated for 30 seconds prior to the collection of data.
- 11.4.7 Samples having concentrations higher than the established linear dynamic range should be diluted into range and reanalyzed. The sample should first be analyzed for the trace elements in the sample, protecting the detector from the high concentration elements, if necessary, by the selection of appropriate scanning windows. The sample should then be diluted for the determination of the remaining elements. Alternatively, the dynamic range may be adjusted by selecting an alternative isotope of lower natural abundance, provided quality control data for that isotope have been established. The dynamic range must not be adjusted by altering instrument conditions to an uncharacterized state.

12.0 DATA ANALYSIS AND CALCULATIONS

- 12.1 Elemental equations recommended for sample data calculations are listed in Table 5. Sample data should be reported in units of $\mu\text{g/L}$ for aqueous samples or mg/kg dry weight for solid samples. Do not report element concentrations below the determined MDL.
- 12.2 For data values less than 10, two significant figures should be used for reporting element concentrations. For data values greater than or equal to 10, three significant figures should be used.
- 12.3 For aqueous samples prepared by total recoverable procedure (Section 11.2), multiply solution concentrations by the dilution factor 1.25. If additional dilutions were made to any samples or an aqueous sample was prepared using the acid-mixture procedure described in Section 11.3, the appropriate factor should be applied to the calculated sample concentrations.

- 12.4 For total recoverable analytes in solid samples (Section 11.3), round the solution analyte concentrations ($\mu\text{g/L}$ in the analysis solution) as instructed in Section 12.2. Multiply the $\mu\text{g/L}$ concentrations in the analysis solution by the factor 0.005 to calculate the mg/L analyte concentration in the 100 mL extract solution. (If additional dilutions were made to any samples, the appropriate factor should be applied to calculate analyte concentrations in the extract solution.) Report the data up to three significant figures as mg/kg dry-weight basis unless specified otherwise by the program or data user. Calculate the concentration using the equation below:

$$\text{Sample Conc. (mg/kg)}_{\text{dry-weight basis}} = \frac{C \times V}{W}$$

where:

C = Concentration in the extract (mg/L)

V = Volume of extract (L, 100 mL = 0.1L)

W = Weight of sample aliquot extracted ($\text{g} \times 0.001 = \text{kg}$)

Do not report analyte data below the estimated solids MDL or an adjusted MDL because of additional dilutions required to complete the analysis.

- 12.5 To report percent solids in solid samples (Sect. 11.3) calculate as follows:

$$\% \text{ solids (S)} = \frac{DW}{WW} \times 100$$

where:

DW = Sample weight (g) dried at 60°C

WW = Sample weight (g) before drying

Note: If the data user, program or laboratory requires that the reported percent solids be determined by drying at 105°C , repeat the procedure given in Section 11.3 using a separate portion ($>20 \text{ g}$) of the sample and dry to constant weight at $103\text{-}105^\circ\text{C}$.

- 12.6 Data values should be corrected for instrument drift or sample matrix induced interferences by the application of internal standardization. Corrections for characterized spectral interferences should be applied to the data. Chloride interference corrections should be made on all samples, regardless of the addition of hydrochloric acid, as the chloride ion is a common constituent of environmental samples.
- 12.7 If an element has more than one monitored isotope, examination of the concentration calculated for each isotope, or the isotope ratios, will provide useful information for the analyst in detecting a possible spectral interference.

Consideration should therefore be given to both primary and secondary isotopes in the evaluation of the element concentration. In some cases, secondary isotopes may be less sensitive or more prone to interferences than the primary recommended isotopes, therefore differences between the results do not necessarily indicate a problem with data calculated for the primary isotopes.

- 12.8 The QC data obtained during the analyses provide an indication of the quality of the sample data and should be provided with the sample results.

13.0 METHOD PERFORMANCE

- 13.1 Instrument operating conditions used for single laboratory testing of the method are summarized in Table 6. Total recoverable digestion and "direct analysis" MDLs determined using the procedure described in Section 9.2.4, are listed in Table 7.
- 13.2 Data obtained from single laboratory testing of the method are summarized in Table 9 for five water samples representing drinking water, surface water, ground water and waste effluent. Samples were prepared using the procedure described in Section 11.2. For each matrix, five replicates were analyzed and the average of the replicates used for determining the sample background concentration for each element. Two further pairs of duplicates were fortified at different concentration levels. For each method element, the sample background concentration, mean percent recovery, the standard deviation of the percent recovery and the relative percent difference between the duplicate fortified samples are listed in Table 8.
- 13.3 Data obtained from single laboratory testing of the method are summarized in Table 10 for three solid samples consisting of SRM 1645 River Sediment, EPA Hazardous Soil and EPA Electroplating Sludge. Samples were prepared using the procedure described in Section 11.3. For each method element, the sample background concentration, mean percent recovery, the standard deviation of the percent recovery and the relative percent difference between the duplicate fortified samples were determined as for Section 13.2.
- 13.4 Data obtained from single laboratory testing of the method for drinking water analysis using the "direct analysis" procedure (Section 11.2.1) are given in Table 11. Three drinking water samples of varying hardness collected from Regions 4, 6, and 10 were fortified to contain 1 µg/L of all metal primary contaminants, except selenium, which was added to a concentration of 20 µg/L. For each matrix, four replicate aliquots were analyzed to determine the sample background concentration of each analyte and four fortified aliquots were analyzed to determine mean percent recovery in each matrix. Listed in the Table 11 are the average mean percent recovery of each analyte in the three matrices and the standard deviation of the mean percent recoveries.
- 13.5 Listed in Table 12 are the regression equations for precision and bias developed from the joint USEPA/Association of Official Analytical Chemists (AOAC) multilaboratory validation study conducted on this method. These equations

were developed from data received from 13 laboratories on reagent water, drinking water and ground water. Listed in Tables 13 and 14, respectively, are the precision and recovery data from a wastewater digestate supplied to all laboratories and from a wastewater of the participant's choice. For a complete review of the study see Reference 11, Section 16.0 of this method.

14.0 POLLUTION PREVENTION

- 14.1 Pollution prevention encompasses any technique that reduces or eliminates the quantity or toxicity of waste at the point of generation. Numerous opportunities for pollution prevention exist in laboratory operation. The EPA has established a preferred hierarchy of environmental management techniques that places pollution prevention as the management option of first choice. Whenever feasible, laboratory personnel should use pollution prevention techniques to address their waste generation. When wastes cannot be feasibly reduced at the source, the Agency recommends recycling as the next best option.
- 14.2 For information about pollution prevention that may be applicable to laboratories and research institutions, consult "Less is Better: Laboratory Chemical Management for Waste Reduction", available from the American Chemical Society's Department of Government Relations and Science Policy, 1155 16th Street N.W., Washington D.C. 20036, (202)872-4477.

15.0 WASTE MANAGEMENT

- 15.1 The Environmental Protection Agency requires that laboratory waste management practices be conducted consistent with all applicable rules and regulations. The Agency urges laboratories to protect the air, water, and land by minimizing and controlling all releases from hoods and bench operations, complying with the letter and spirit of any sewer discharge permits and regulations, and by complying with all solid and hazardous waste regulations, particularly the hazardous waste identification rules and land disposal restrictions. For further information on waste management consult "The Waste Management Manual for Laboratory Personnel", available from the American Chemical Society at the address listed in the Section 14.2.

16.0 REFERENCES

1. Gray, A.L. and A. R. Date. Inductively Coupled Plasma Source Mass Spectrometry Using Continuum Flow Ion Extraction. *Analyst* 108 1033-1050, 1983.
2. Houk, R.S. et al. Inductively Coupled Argon Plasma as an Ion Source for Mass Spectrometric Determination of Trace Elements. *Anal Chem.* 52 2283-2289, 1980.
3. Houk, R.S. Mass Spectrometry of Inductively Coupled Plasmas. *Anal. Chem.* 58 97A-105A, 1986.
4. Thompson, J.J. and R. S. Houk. A Study of Internal Standardization in Inductively Coupled Plasma-Mass Spectrometry. *Appl. Spec.* 41 801-806, 1987.

5. Carcinogens - Working With Carcinogens, Department of Health, Education, and Welfare, Public Health Service, Center for Disease Control, National Institute for Occupational Safety and Health, Publication No. 77-206, Aug. 1977. Available from the National Technical Information Service (NTIS) as PB-277256.
6. OSHA Safety and Health Standards, General Industry, (29 CFR 1910), Occupational Safety and Health Administration, OSHA 2206, (Revised, January 1976).
7. Safety in Academic Chemistry Laboratories, American Chemical Society Publication, Committee on Chemical Safety, 3rd Edition, 1979.
8. Proposed OSHA Safety and Health Standards, Laboratories, Occupational Safety and Health Administration, Federal Register, July 24, 1986.
9. American Society for Testing and Materials. Standard Specification for Reagent Water, D1193-77. Annual Book of ASTM Standards, Vol. 11.01. Philadelphia, PA, 1991.
10. Code of Federal Regulations 40, Ch. 1, Pt. 136 Appendix B.
11. Longbottom, J.E. et. al. Determination of Trace Elements in Water by Inductively Coupled Plasma-Mass Spectrometry: Collaborative Study, Journal of AOAC International 77 1004-1023, 1994.
12. Hinnners, T.A. Interferences in ICP-MS by Bromine Species. Winter Conference on Plasma Spectrochemistry, San Diego, CA, January, 10-15, 1994.

17.0 TABLES, DIAGRAMS, FLOWCHARTS, AND VALIDATION DATA**TABLE 1: ESTIMATED INSTRUMENT DETECTION LIMITS**

Element	Recommended Analytical Mass	Scanning Mode¹	Selection Ion Monitoring Mode^{2,3}
Aluminum	27	0.05	0.02
Antimony	123	0.08	0.008
Arsenic ⁽³⁾	75	0.9	0.02
Barium	137	0.5	0.03
Beryllium	9	0.1	0.02
Cadmium	111	0.1	0.02
Chromium	52	0.07	0.04
Cobalt	59	0.03	0.002
Copper	63	0.03	0.004
Lead	206, 207, 208	0.08	0.015
Manganese	55	0.1	0.007
Mercury	202	n.a	0.2
Molybdenum	98	0.1	0.005
Nickel	60	0.2	0.07
Selenium ⁽³⁾	82	5	1.3
Silver	107	0.05	0.004
Thallium	205	0.09	0.014
Thorium	232	0.03	0.005
Uranium	238	0.02	0.005
Vanadium	51	0.02	0.006
Zinc	66	0.2	0.07

Instrument detection limits (3σ) estimated from seven replicate integrations of the blank (1% v/v nitric acid) following calibration of the instrument with three replicate integrations of a multi-element standard.

¹Instrument operating conditions and data acquisition mode are given in Table 6.

²IDLs determined using state-of-the-art instrumentation (1994). Data for ⁷⁵As, ⁷⁷Se, and ⁸²Se were acquired using a dwell time of 4.096 seconds with 1500 area count per sec ⁸³Kr present in argon supply. All other data were acquired using a dwell time of 1.024 seconds per AMU monitored.

TABLE 2: COMMON MOLECULAR ION INTERFERENCES IN ICP-MS

BACKGROUND MOLECULAR IONS

Molecular Ion	Mass	Element Interference ^a
NH ⁺	15	
OH ⁺	17	
OH ₂ ⁺	18	
C ₂ ⁺	24	
CN ⁺	26	
CO ⁺	28	
N ₂ ⁺	28	
N ₂ H ⁺	29	
NO ⁺	30	
NOH ⁺	31	
O ₂ ⁺	32	
O ₂ H ⁺	33	
³⁶ ArH ⁺	37	
³⁸ ArH ⁺	39	
⁴⁰ ArH ⁺	41	
CO ₂ ⁺	44	
CO ₂ H ⁺	45	Sc
ArC ⁺ , ArO ⁺	52	Cr
ArN ⁺	54	Cr
ArNH ⁺	55	Mn
ArO ⁺	56	
ArOH ⁺	57	
⁴⁰ Ar ³⁶ Ar ⁺	76	Se
⁴⁰ Ar ³⁸ Ar ⁺	78	Se
⁴⁰ Ar ⁺	80	Se

^amethod elements or internal standards affected by the molecular ions.

TABLE 2: COMMON MOLECULAR ION INTERFERENCES IN ICP-MS (Cont'd)

MATRIX MOLECULAR IONS		
Molecular Ion	Mass	Element Interference^a
Bromide¹²		
$^{81}\text{BrH}^+$	82	Se
$^{79}\text{BrO}^+$	95	Mo
$^{81}\text{BrO}^+$	97	Mo
$^{81}\text{BrOH}^+$	98	Mo
$\text{Ar}^{81}\text{Br}^+$	121	Sb
Chloride		
$^{35}\text{ClO}^+$	51	V
$^{35}\text{ClOH}^+$	52	Cr
$^{37}\text{ClO}^+$	53	Cr
$^{37}\text{ClOH}^+$	54	Cr
$\text{Ar}^{35}\text{Cl}^+$	75	As
$\text{Ar}^{37}\text{Cl}^+$	77	Se
Sulphate		
$^{32}\text{SO}^+$	48	
$^{32}\text{SOH}^+$	49	
$^{34}\text{SO}^+$	50	V, Cr
$^{34}\text{SOH}^+$	51	V
$\text{SO}_2^+, \text{S}_2^+$	64	Zn
Ar^{32}S^+	72	
Ar^{34}S^+	74	
Phosphate		
PO^+	47	
POH^+	48	
PO_2^+	63	Cu
ArP^+	71	
Group I, II Metals		
ArNa^+	63	Cu
ArK^+	79	
ArCa^+	80	

TABLE 2: COMMON MOLECULAR ION INTERFERENCES IN ICP-MS (Cont'd)**MATRIX MOLECULAR IONS**

Molecular Ion	Mass	Element Interference^a
Matrix Oxides [*]		
TiO	62-66	Ni, Cu, Zn
ZrO	106-112	Ag, Cd
MoO	108-116	Cd

^{*}Oxide interferences will normally be very small and will only impact the method elements when present at relatively high concentrations. Some examples of matrix oxides are listed of which the analyst should be aware. It is recommended that Ti and Zr isotopes are monitored in solid waste samples, which are likely to contain high levels of these elements. Mo is monitored as a method analyte.

TABLE 3: INTERNAL STANDARDS AND LIMITATIONS OF USE

Internal Standard	Mass	Possible Limitation
⁶ Lithium	6	a
Scandium	45	polyatomic ion interference
Yttrium	89	a,b
Rhodium	103	
Indium	115	isobaric interference by Sn
Terbium	159	
Holmium	165	
Lutetium	175	
Bismuth	209	a

a May be present in environmental samples.

b In some instruments Yttrium may form measurable amounts of YO⁺ (105 amu) and YOH⁺ (106 amu). If this is the case, care should be taken in the use of the cadmium elemental correction equation.

Internal standards recommended for use with this method are shown in bold face. Preparation procedures for these are included in Section 7.3.

TABLE 4: RECOMMENDED ANALYTICAL ISOTOPES AND ADDITIONAL MASSES WHICH MUST BE MONITORED

Isotope	Element of Interest
<u>27</u>	Aluminum
121, <u>123</u>	Antimony
<u>75</u>	Arsenic
135, <u>137</u>	Barium
<u>9</u>	Beryllium
106, 108, <u>111</u> , 114	Cadmium
<u>52</u> , 53	Chromium
<u>59</u>	Cobalt
<u>63</u> , 65	Copper
<u>206</u> , <u>207</u> , <u>208</u>	Lead
<u>55</u>	Manganese
95, 97, <u>98</u>	Molybdenum
<u>60</u> , 62	Nickel
77, <u>82</u>	Selenium
<u>107</u> , 109	Silver
<u>203</u> , <u>205</u>	Thallium
<u>232</u>	Thorium
<u>238</u>	Uranium
<u>51</u>	Vanadium
<u>66</u> , 67, 68	Zinc
83	Krypton
99	Ruthenium
105	Palladium
118	Tin

NOTE: Isotopes recommended for analytical determination are underlined.

TABLE 5: RECOMMENDED ELEMENTAL EQUATIONS FOR DATA CALCULATIONS

Element	Elemental Equation	Note
Al	(1.000) (²⁷ C)	
Sb	(1.000) (¹²³ C)	
As	(1.000) (⁷⁵ C)-(3.127) [(⁷⁷ C)-(0.815) (⁸² C)]	(1)
Ba	(1.000) (¹³⁷ C)	
Be	(1.000) (⁹ C)	
Cd	(1.000) (¹¹¹ C)-(1.073) [(¹⁰⁸ C)-(0.712) (¹⁰⁶ C)]	(2)
Cr	(1.000) (⁵² C)	(3)
Co	(1.000) (⁵⁹ C)	
Cu	(1.000) (⁶³ C)	
Pb	(1.000) (²⁰⁶ C)+(1.000) [(²⁰⁷ C)+(1.000) (²⁰⁸ C)]	(4)
Mn	(1.000) (⁵⁵ C)	
Mo	(1.000) (⁹⁸ C)-(0.146) (⁹⁹ C)	(5)
Ni	(1.000) (⁶⁰ C)	
Se	(1.000) (⁸² C)	(6)
Ag	(1.000) (¹⁰⁷ C)	
Tl	(1.000) (²⁰⁵ C)	
Th	(1.000) (²³² C)	
U	(1.000) (²³⁸ C)	
V	(1.000) (⁵¹ C)-(3.127) [(⁵³ C)-(0.113) (⁶² C)]	(7)
Zn	(1.000) (⁶⁶ C)	

TABLE 5: RECOMMENDED ELEMENTAL EQUATIONS FOR DATA CALCULATIONS

Element	Elemental Equation	Note
Bi	(1.000) (²⁰⁹ C)	
In	(1.000) (²⁰⁹ C)-(0.016) (¹¹⁸ C)	(8)
Sc	(1.000) (⁴⁵ C)	
Tb	(1.000) (¹⁵⁹ C)	
Y	(1.000) (⁸⁹ C)	

C - Calibration blank subtracted counts at specified mass.

(1) - Correction for chloride interference with adjustment for ⁷⁷Se. ArCl 75/77 ratio may be determined from the reagent blank. Isobaric mass 82 must be from Se only and not BrH⁺.

(2) - Correction for MoO interference. Isobaric mass 106 must be from Cd only not ZrO⁺. An additional isobaric elemental correction should be made if palladium is present.

(3) - In 0.4% v/v HCl, the background from ClOH will normally be small. However the contribution may be estimated from the reagent blank. Isobaric mass must be from Cr only not ArC⁺.

(4) - Allowance for isotopic variability of lead isotopes.

(5) - Isobaric elemental correction for ruthenium.

(6) - Some argon supplies contain krypton as an impurity. Selenium is corrected for ⁸²Kr by background subtraction.

(7) - Correction for chloride interference with adjustment for ⁵³Cr. ClO 51/53 ratio may be determined from the reagent blank. Isobaric mass 52 must be from Cr only not ArC⁺.

(8) - Isobaric elemental correction for tin.

**TABLE 6: INSTRUMENT OPERATING CONDITIONS FOR PRECISION
AND RECOVERY DATA¹**

Instrument	VG PlasmaQuad Type I
Plasma forward power	1.35 kW
Coolant flow rate	13.5 L/min.
Auxillary flow rate	0.6 L/min.
Nebulizer flow rate	0.78 L/min.
Solution uptake rate	0.6 mL/min.
Spray chamber temperature	15°C
Data Acquisition	
Detector mode	Pulse counting
Replicate integrations	3
Mass range	8-240 amu
Dwell time	320 µs
Number of MCA channels	2048
Number of scan sweeps	85
Total acquisition time	3 minutes per sample

¹The described instrument and operating conditions were used to determine the scanning mode MDL data listed in Table 7 and the precision and recovery data given in Tables 9 and 10.

TABLE 7: METHOD DETECTION LIMITS

AMU	Element	Scanning Mode ¹		Selection Ion Monitoring Mode ²	
		Total Recoverable		Total Recoverable	Direct Analysis ³
		Aqueous µg/L	Solids mg/kg	Aqueous µg/L	Aqueous µg/L
27	Al	1.0	0.4	1.7	0.04
123	Sb	0.4	0.2	0.04	0.02
75	As	1.4	0.6	0.4	0.1
137	Ba	0.8	0.4	0.04	0.04
9	Be	0.3	0.1	0.02	0.03
111	Cd	0.5	0.2	0.03	0.03
52	Cr	0.9	0.4	0.08	0.08
59	Co	0.09	0.04	0.004	0.003
63	Cu	0.5	0.2	0.02	0.01
206,207,208	Pb	0.6	0.3	0.05	0.02
55	Mn	0.1	0.05	0.02	0.04
202	Hg	n.a.	n.a.	n.a.	0.2
98	Mo	0.3	0.1	0.01	0.01
60	Ni	0.5	0.2	0.06	0.03
82	Se	7.9	3.2	2.1	0.5
107	Ag	0.1	0.05	0.005	0.005
205	Tl	0.3	0.1	0.02	0.01
232	Th	0.1	0.05	0.02	0.01
238	U	0.1	0.05	0.01	0.01
51	V	2.5	1.0	0.9	0.05
66	Zn	1.8	0.7	0.1	0.2

¹Data acquisition mode given in Table 6. Total recoverable MDL concentrations are computed for original matrix with allowance for sample dilution during preparation. Listed MDLs for solids calculated from determined aqueous MDLs.

²MDLs determined using state-of-the-art instrumentation (1994). Data for ⁷⁵As, ⁷⁷Se, and ⁸²Se were acquired using a dwell time of 4.096 seconds with 1500 area count per seconds ⁸³Kr present in argon supply. All other data were acquired using a dwell time of 1.024 seconds per AMU monitored.

³MDLs were determined from analysis of seven undigested aqueous sample aliquots.

n.a. - Not applicable. Total recoverable digestion not suitable for organo-mercury compounds.

TABLE 8: ACCEPTANCE LIMITS FOR QC CHECK SAMPLE

METHOD PERFORMANCE ($\mu\text{g/L}$)¹

Element	QC Check Sample Conc.	Average Recovery	Standard Deviation² (S_r)	Acceptance Limits³ $\mu\text{g/L}$
Aluminum	100	100.4	5.49	84-117
Antimony	100	99.9	2.40	93-107
Arsenic	100	101.6	3.66	91-113
Barium	100	99.7	2.64	92-108
Beryllium	100	105.9	4.13	88-112 ⁴
Cadmium	100	100.8	2.32	94-108
Chromium	100	102.3	3.91	91-114
Cobalt	100	97.7	2.66	90-106
Copper	100	100.3	2.11	94-107
Lead	100	104.0	3.42	94-114
Manganese	100	98.3	2.71	90-106
Molybdenum	100	101.0	2.21	94-108
Nickel	100	100.1	2.10	94-106
Selenium	100	103.5	5.67	86-121
Silver	100	101.1	3.29	91-111 ⁵
Thallium	100	98.5	2.79	90-107
Thorium	100	101.4	2.60	94-109
Uranium	100	102.6	2.82	94-111
Vanadium	100	100.3	3.26	90-110
Zinc	100	105.1	4.57	91-119

¹Method performance characteristics calculated using regression equations from collaborative study, Reference 11.

²Single-analyst standard deviation, S_r.

³Acceptance limits calculated as average recovery \pm three standard deviations.

⁴Acceptance limits centered at 100% recovery.

⁵Statistics estimated from summary statistics at 48 and 64 $\mu\text{g/L}$.

TABLE 9: PRECISION AND RECOVERY DATA IN AQUEOUS MATRICES

DRINKING WATER									
Element	Sample	Low	Average			High	Average		
	Conc.	Spike	Recovery	S (R)	RPD	Spike	Recovery	S (R)	RPD
	µg/L	µg/L	R (%)			µg/L	R (%)		
Al	175	50	115.8	5.9	0.4	200	102.7	1.6	1.1
Sb	<0.4	10	99.1	0.7	2.0	100	100.8	0.7	2.0
As	<1.4	50	99.7	0.8	2.2	200	102.5	1.1	2.9
Ba	43.8	50	94.8	3.9	5.8	200	95.6	0.8	1.7
Be	<0.3	10	113.5	0.4	0.9	100	111.0	0.7	1.8
Cd	<0.5	10	97.0	2.8	8.3	100	101.5	0.4	1.0
Cr	<0.9	10	111.0	3.5	9.0	100	99.5	0.1	0.2
Co	0.11	10	94.4	0.4	1.1	100	93.6	0.5	1.4
Cu	3.6	10	101.8	8.8	17.4	100	91.6	0.3	0.3
Pb	0.87	10	97.8	2.0	2.8	100	99.0	0.8	2.2
Mn	0.96	10	96.9	1.8	4.7	100	95.8	0.6	1.8
Mo	1.9	10	99.4	1.6	3.4	100	98.6	0.4	1.0
Ni	1.9	10	100.2	5.7	13.5	100	95.2	0.5	1.3
Se	<7.9	50	99.0	1.8	5.3	200	93.5	3.5	10.7
Ag	<0.1	50	100.7	1.5	4.2	200	99.0	0.4	1.0
Tl	<0.3	10	97.5	0.4	1.0	100	98.5	1.7	4.9
Th	<0.1	10	109.0	0.7	1.8	100	106.0	1.4	3.8
U	0.23	10	110.7	1.4	3.5	100	107.8	0.7	1.9
V	<2.5	50	101.4	0.1	0.4	200	97.5	0.7	2.1
Zn	5.2	50	103.4	3.3	7.7	200	96.4	0.5	1.0

S (R) Standard deviation of percent recovery.

RPD Relative percent difference between duplicate spike determinations.

< Sample concentration below established method detection limit.

**TABLE 9: PRECISION AND RECOVERY DATA IN AQUEOUS
MATRICES (Cont'd)**

<u>WELL WATER</u>									
Element	Sample	Low	Average			High	Average		
	Conc. µg/L	Spike µg/L	Recovery R (%)	S (R)	RPD	Spike µg/L	Recovery R (%)	S (R)	RPD
Al	34.3	50	100.1	3.9	0.8	200	102.6	1.1	1.3
Sb	0.46	10	98.4	0.9	1.9	100	102.5	0.7	1.9
As	<1.4	50	110.0	6.4	16.4	200	101.3	0.2	0.5
Ba	106	50	95.4	3.9	3.3	200	104.9	1.0	1.6
Be	<0.3	10	104.5	0.4	1.0	100	101.4	1.2	3.3
Cd	106	10	88.6	1.7	3.8	100	98.6	0.6	1.6
Cr	<0.9	10	111.0	0.0	0.0	100	103.5	0.4	1.0
Co	2.4	10	100.6	1.0	1.6	100	104.1	0.4	0.9
Cu	37.4	10	104.3	5.1	1.5	100	100.6	0.8	1.5
Pb	3.5	10	95.2	2.5	1.5	100	99.5	1.4	3.9
Mn	2770	10	*	*	1.8	100	*	*	0.7
Mo	2.1	10	103.8	1.1	1.6	100	102.9	0.7	1.9
Ni	11.4	10	116.5	6.3	6.5	100	99.6	0.3	0.0
Se	<7.9	50	127.3	8.4	18.7	200	101.3	0.2	0.5
Ag	<0.1	50	99.2	0.4	1.0	200	101.5	1.4	3.9
Tl	<0.3	10	93.9	0.1	0.0	100	100.4	1.8	5.0
Th	<0.1	10	103.0	0.7	1.9	100	104.5	1.8	4.8
U	1.8	10	106.0	1.1	1.6	100	109.7	2.5	6.3
V	<2.5	50	105.3	0.8	2.1	200	105.8	0.2	0.5
Zn	554	50	*	*	1.2	200	102.1	5.5	3.2

S (R) Standard deviation of percent recovery.

RPD Relative percent difference between duplicate spike determinations.

< Sample concentration below established method detection limit.

* Spike concentration <10% of sample background concentration.

**TABLE 9: PRECISION AND RECOVERY DATA IN AQUEOUS
MATRICES (Cont'd)**

POND WATER									
Element	Sample	Low	Average			High	Average		
	Conc. µg/L	Spike µg/L	Recovery R (%)	S (R)	RPD	Spike µg/L	Recovery R (%)	S (R)	RPD
Al	610	50	*	*	1.7	200	78.2	9.2	5.5
Sb	<0.4	10	101.1	1.1	2.9	100	101.5	3.0	8.4
As	<1.4	50	100.8	2.0	5.6	200	96.8	0.9	2.6
Ba	28.7	50	102.1	1.8	2.4	200	102.9	3.7	9.0
Be	<0.3	10	109.1	0.4	0.9	100	114.4	3.9	9.6
Cd	<0.5	10	106.6	3.2	8.3	100	105.8	2.8	7.6
Cr	2.0	10	107.0	1.0	1.6	100	100.0	1.4	3.9
Co	0.79	10	101.6	1.1	2.7	100	101.7	1.8	4.9
Cu	5.4	10	107.5	1.4	1.9	100	98.1	2.5	6.8
Pb	1.9	10	108.4	1.5	3.2	100	106.1	0.0	0.0
Mn	617	10	*	*	1.1	100	139.0	11.1	4.0
Mo	0.98	10	104.2	1.4	3.5	100	104.0	2.1	5.7
Ni	2.5	10	102.0	2.3	4.7	100	102.5	2.1	5.7
Se	<7.9	50	102.7	5.6	15.4	200	105.5	1.4	3.8
Ag	0.12	50	102.5	0.8	2.1	200	105.2	2.7	7.1
Tl	<0.3	10	108.5	3.2	8.3	100	105.0	2.8	7.6
Th	0.19	10	93.1	3.5	10.5	100	93.9	1.6	4.8
U	0.30	10	107.0	2.8	7.3	100	107.2	1.8	4.7
V	3.5	50	96.1	5.2	14.2	200	101.5	0.2	0.5
Zn	6.8	50	99.8	1.7	3.7	200	100.1	2.8	7.7

S (R) Standard deviation of percent recovery.

RPD Relative percent difference between duplicate spike determinations.

< Sample concentration below established method detection limit.

* Spike concentration <10% of sample background concentration.

**TABLE 9: PRECISION AND RECOVERY DATA IN AQUEOUS
MATRICES (Cont'd)**

SEWAGE TREATMENT PRIMARY EFFLUENT

Element	Sample	Low	Average			High	Average		
	Conc. µg/L	Spike µg/L	Recovery R (%)	S (R)	RPD	Spike µg/L	Recovery R (%)	S (R)	RPD
Al	1150	50	*	*	3.5	200	100.0	13.8	1.5
Sb	1.5	10	95.7	0.4	0.9	100	104.5	0.7	1.9
As	<1.4	50	104.2	4.5	12.3	200	101.5	0.7	2.0
Ba	202	50	79.2	9.9	2.5	200	108.6	4.6	5.5
Be	<0.3	10	110.5	1.8	4.5	100	106.4	0.4	0.9
Cd	9.2	10	101.2	1.3	0.0	100	102.3	0.4	0.9
Cr	128	10	*	*	1.5	100	102.1	1.7	0.4
Co	13.4	10	95.1	2.7	2.2	100	99.1	1.1	2.7
Cu	171	10	*	*	2.4	100	105.2	7.1	0.7
Pb	17.8	10	95.7	3.8	1.1	100	102.7	1.1	2.5
Mn	199	10	*	*	1.5	100	103.4	2.1	0.7
Mo	136	10	*	*	1.4	100	105.7	2.4	2.1
Ni	84.0	10	88.4	16.3	4.1	100	98.0	0.9	0.0
Se	<7.9	50	112.0	10.9	27.5	200	108.8	3.0	7.8
Ag	10.9	50	97.1	0.7	1.5	200	102.6	1.4	3.7
Tl	<0.3	10	97.5	0.4	1.0	100	102.0	0.0	0.0
Th	0.11	10	15.4	1.8	30.3	100	29.3	0.8	8.2
U	0.71	10	109.4	1.8	4.3	100	109.3	0.7	1.8
V	<2.5	50	90.9	0.9	0.6	200	99.4	2.1	6.0
Zn	163	50	85.8	3.3	0.5	200	102.0	1.5	1.9

S (R) Standard deviation of percent recovery.

RPD Relative percent difference between duplicate spike determinations.

< Sample concentration below established method detection limit.

* Spike concentration <10% of sample background concentration.

**TABLE 9: PRECISION AND RECOVERY DATA IN AQUEOUS
MATRICES (Cont'd)**

INDUSTRIAL EFFLUENT									
Element	Sample	Low	Average			High	Average		
	Conc.	Spike	Recovery	S (R)	RPD	Spike	Recovery	S (R)	RPD
	µg/L	µg/L	R (%)			µg/L	R (%)		
Al	44.7	50	98.8	8.7	5.7	200	90.4	2.1	2.2
Sb	2990	10	*	*	0.3	100	*	*	0.0
As	<1.4	50	75.1	1.8	6.7	200	75.0	0.0	0.0
Ba	100	50	96.7	5.5	3.4	200	102.9	1.1	0.7
Be	<0.3	10	103.5	1.8	4.8	100	100.0	0.0	0.0
Cd	10.1	10	106.5	4.4	2.4	100	97.4	1.1	2.8
Cr	171	10	*	*	0.0	100	127.7	2.4	1.7
Co	1.3	10	90.5	3.2	8.7	100	90.5	0.4	1.3
Cu	101	10	*	*	0.9	100	92.5	2.0	1.6
Pb	294	10	*	*	2.6	100	108.4	2.1	0.0
Mn	154	10	*	*	2.8	100	103.6	3.7	1.6
Mo	1370	10	*	*	1.4	100	*	*	0.7
Ni	17.3	10	107.4	7.4	5.0	100	88.2	0.7	1.0
Se	15.0	50	129.5	9.3	15.1	200	118.3	1.9	3.6
Ag	<0.1	50	91.8	0.6	1.7	200	87.0	4.9	16.1
Tl	<0.3	10	90.5	1.8	5.5	100	98.3	1.0	2.8
Th	0.29	10	109.6	1.2	2.7	100	108.7	0.0	0.0
U	0.17	10	104.8	2.5	6.6	100	109.3	0.4	0.9
V	<2.5	50	74.9	0.1	0.3	200	72.0	0.0	0.0
Zn	43.4	50	85.0	4.0	0.6	200	97.6	1.0	0.4

S (R) Standard deviation of percent recovery.

RPD Relative percent difference between duplicate spike determinations.

< Sample concentration below established method detection limit.

* Spike concentration <10% of sample background concentration.

TABLE 10: PRECISION AND RECOVERY DATA IN SOLID MATRICES

EPA HAZARDOUS SOIL #884

Element	Sample Conc. (mg/kg)	Low ⁺ Spike (mg/kg)	Average Recovery			High ⁺ Spike (mg/kg)	Average Recovery		
			R (%)	S (R)	RPD		R (%)	S (R)	RPD
Al	5170	20	*	*	–	100	*	*	–
Sb	5.4	20	69.8	2.5	4.7	100	70.4	1.8	6.5
As	8.8	20	104.7	5.4	9.1	100	102.2	2.2	5.4
Ba	113	20	54.9	63.6	18.6	100	91.0	9.8	0.5
Be	0.6	20	100.1	0.6	1.5	100	102.9	0.4	1.0
Cd	1.8	20	97.3	1.0	1.4	100	101.7	0.4	1.0
Cr	83.5	20	86.7	16.1	8.3	100	105.5	1.3	0.0
Co	7.1	20	98.8	1.2	1.9	100	102.9	0.7	1.8
Cu	115	20	86.3	13.8	3.4	100	151.7	4.2	4.6
Pb	152	20	85.0	45.0	13.9	100	85.2	25.7	23.7
Mn	370	20	*	*	12.7	100	95.2	10.4	2.2
Mo	4.8	20	95.4	1.5	2.9	100	102.3	0.7	2.0
Ni	19.2	20	101.7	3.8	1.0	100	100.7	0.8	0.8
Se	<3.2	20	79.5	7.4	26.4	100	94.8	9.4	26.5
Ag	1.1	20	96.1	0.6	0.5	100	97.9	0.8	2.3
Tl	0.24	20	94.3	1.1	3.1	100	76.0	1.0	2.9
Th	1.0	20	69.8	0.6	1.3	100	102.9	2.2	7.9
U	1.1	20	100.1	0.2	0.0	100	106.7	0.0	0.0
V	17.8	20	109.2	4.2	2.3	100	113.4	1.3	2.4
Zn	128	20	87.0	27.7	5.5	100		12.9	14.1

S (R) Standard deviation of percent recovery.

RPD Relative percent difference between duplicate spike determinations.

< Sample concentration below established method detection limit.

* Spike concentration <10% of sample background concentration.

– Not determined.

⁺ Equivalent.

TABLE 10: PRECISION AND RECOVERY DATA IN SOLID MATRICES

NBS 1645 RIVER SEDIMENT

Element	Sample Conc. (mg/kg)	Low ⁺ Spike (mg/kg)	Average Recovery			High ⁺ Spike (mg/kg)	Average Recovery		
			R (%)	S (R)	RPD		R (%)	S (R)	RPD
Al	5060	20	*	*	–	100	*	*	–
Sb	21.8	20	73.9	6.5	9.3	100	81.2	1.5	3.9
As	67.2	20	104.3	13.0	7.6	100	107.3	2.1	2.9
Ba	54.4	20	105.6	4.9	2.8	100	98.6	2.2	3.9
Be	0.59	20	88.8	0.2	0.5	100	87.9	0.1	0.2
Cd	8.3	20	92.9	0.4	0.0	100	95.7	1.4	3.9
Cr	29100	20	*	*	–	100	*	*	–
Co	7.9	20	97.6	1.3	2.6	100	103.1	0.0	0.0
Cu	112	20	121.0	9.1	1.5	100	105.2	2.2	1.8
Pb	742	20	*	*	–	100	–	–	–
Mn	717	20	*	*	–	100	–	–	–
Mo	17.1	20	89.8	8.1	12.0	100	98.4	0.7	0.9
Ni	41.8	20	103.7	6.5	4.8	100	102.2	0.8	0.0
Se	<3.2	20	108.3	14.3	37.4	100	93.9	5.0	15.1
Ag	1.8	20	94.8	1.6	4.3	100	96.2	0.7	1.9
Tl	1.2	20	91.2	1.3	3.6	100	94.4	0.4	1.3
Th	0.90	20	91.3	0.9	2.6	100	92.3	0.9	2.8
U	0.79	20	95.6	1.8	5.0	100	98.5	1.2	3.5
V	21.8	20	91.8	4.6	5.7	100	100.7	0.6	0.8
Zn	1780	20	*	*	–	100	*	*	–

S (R) Standard deviation of percent recovery.

RPD Relative percent difference between duplicate spike determinations.

< Sample concentration below established method detection limit.

* Spike concentration <10% of sample background concentration.

– Not determined.

⁺ Equivalent.

TABLE 10: PRECISION AND RECOVERY DATA IN SOLID MATRICES

EPA ELECTROPLATING SLUDGE #286									
Element	Sample Conc. (mg/kg)	Low ⁺ Spike (mg/kg)	Average Recovery			High ⁺ Spike (mg/kg)	Average Recovery		
			R (%)	S (R)	RPD		R (%)	S (R)	RPD
Al	5110	20	*	*	-	100	*	*	-
Sb	8.4	20	55.4	1.5	4.1	100	61.0	0.2	0.9
As	41.8	20	91.0	2.3	1.7	100	94.2	0.8	1.5
Ba	27.3	20	1.8	7.1	8.3	100	0	1.5	10.0
Be	0.25	20	92.0	0.9	2.7	100	93.4	0.3	0.9
Cd	112	20	85.0	5.2	1.6	100	88.5	0.8	0.5
Cr	7980	20	*	*	-	100	*	*	-
Co	4.1	20	89.2	1.8	4.6	100	88.7	1.5	4.6
Cu	740	20	*	*	6.0	100	61.7	20.4	5.4
Pb	1480	20	*	*	-	100	*	*	-
Mn	295	20	*	*	-	100	-	-	-
Mo	13.3	20	82.9	1.2	1.3	100	89.2	0.4	1.0
Ni	450	20	*	*	6.8	100	83.0	10.0	4.5
Se	3.5	20	89.7	3.7	4.2	100	91.0	6.0	18.0
Ag	5.9	20	89.8	2.1	4.6	100	85.1	0.4	1.1
Tl	1.9	20	96.9	0.9	2.4	100	98.9	0.9	2.4
Th	3.6	20	91.5	1.3	3.2	100	97.4	0.7	2.0
U	2.4	20	107.7	2.0	4.6	100	109.6	0.7	1.8
V	21.1	20	105.6	1.8	2.1	100	97.4	1.1	2.5
Zn	13300	20	*	*	-	100	*	*	-

S (R) Standard deviation of percent recovery.

RPD Relative percent difference between duplicate spike determinations.

< Sample concentration below established method detection limit.

* Spike concentration <10% of sample background concentration.

- Not determined.

⁺ Equivalent.

**TABLE 11: PRIMARY DRINKING WATER CONTAMINANTS
PRECISION AND RECOVERY DATA**

Analyte	Regional Sample Background Concentration, µg/L			Average Mean ¹ % Recovery	S (R)
	(IV)	(VI)	(X)		
Antimony	0.16	0.07	0.03	114%	1.9
Arsenic	< MDL	2.4	1.0	93	8.5
Barium	4.6	280	14.3	(*)	–
Beryllium	< MDL	< MDL	< MDL	100%	8.2
Cadmium	0.05	0.05	0.03	81	4.0
Chromium	0.71	5.1	0.10	94	2.5
Copper	208	130	14.3	(*)	–
Lead	1.2	1.2	2.5	91	2.6
Mercury	< MDL	0.23	< MDL	86	11.4
Nickel	1.7	3.6	0.52	101%	11.5
Selenium	< MDL	4.3	< MDL	98	8.4
Thallium	< MDL	0.01	< MDL	100	1.4

¹The three regional waters were fortified with 1.0 µg/L of all analytes listed, except selenium, which was fortified to 20 µg/L.

(*) Recovery of barium and copper was not calculated because the analyte addition was <20% the sample background concentration in all waters. (Recovery calculations are not required if the concentration of the analyte added is less than 30% of the sample background concentration. Section 9.4.3).

S (R) Standard deviation of the mean percent recoveries.

TABLE 12: SUMMARY STATISTICS AND DESCRIPTIVE EQUATIONS FOR THE 20 ANALYTES TESTED IN THE COLLABORATIVE STUDY

Analyte	Reagent Water					Finished Drinking Water					Ground Water				
	C ^a	\bar{X}^b	S _R	S _T	Regr. Equations	\bar{X}	S _R	S _T	Regr. Equations	\bar{X}	S _R	S _T	Regr. Equations		
Aluminum	8.00	10.01	2.33	1.74	$\bar{X} = 0.992C + 1.19$	11.18	9.02	6.34	$\bar{X} = 0.954C + 2.38$	9.86	7.10	2.70	$\bar{X} = 0.946C + 2.20$		
	12.00	10.98	5.16		$S_R = 0.056\bar{X} + 2.59^c$	11.02	3.02		$S_R = 7.70^d$	13.40	10.27		$S_R = 0.169\bar{X} + 6.22^e$		
	56.00	59.13	5.55	4.19	$S_T = 0.042X + 1.27$	56.97	7.14	6.18	$S_T = 0.013X + 6.17$	51.75	10.78	16.92	$S_T = 0.172X + 0.75^f$		
	80.00	82.59	4.92			82.73	8.01			82.83	33.37				
	160.00	158.95	11.82	8.90		159.89	11.94	10.59		155.40	15.39	19.27			
	200.00	200.89	8.61			189.98	12.97			189.64	31.46				
Antimony	2.80	2.75	0.27	0.27	$\bar{X} = 0.999C + 0.04$	2.73	0.29	0.17	$\bar{X} = 0.983C + 0.03$	2.82	0.19	0.22	$\bar{X} = 1.003C + 0.01$		
	4.00	4.22	0.46		$S_R = 0.013\bar{X} + 0.61^a$	4.10	0.47		$S_R = 0.049\bar{X} + 0.19$	4.02	0.35		$S_R = 0.059\bar{X} + 0.04$		
	20.00	19.76	1.09	0.85	$S_T = 0.022X + 0.20$	19.17	1.37	0.66	$S_T = 0.026X + 0.08$	20.12	0.82	0.97	$S_T = 0.058X + 0.02$		
	28.00	27.48	1.38			26.48	1.72			27.77	1.38				
	80.00	82.52	2.24	1.76		83.43	2.05	2.46		80.34	9.14	6.80			
	100.00	98.06	1.34			97.19	5.31			101.09	2.89				
Arsenic	8.00	8.64	3.01	3.02	$\bar{X} = 1.013C + 0.50$	9.00	3.13	1.96	$\bar{X} = 0.993C + 0.57$	10.40	5.17	4.90	$\bar{X} = 0.949C + 0.91$		
	12.00	12.58	3.18		$S_R = 0.031\bar{X} + 2.74$	11.37	1.77		$S_R = 0.018\bar{X} + 2.55$	7.85	4.62		$S_R = 0.048\bar{X} + 4.52$		
	56.00	55.44	4.64	3.51	$S_T = 0.007X + 2.95$	53.77	4.12	4.07	$S_T = 0.031X + 1.65$	53.25	3.49	7.88	$S_T = 0.059X + 4.29$		
	80.00	85.15	2.54			87.72	4.14			83.60	12.46				
	160.00	161.80	11.15	3.96		157.56	4.83	6.30		159.86	11.67	14.94			
	200.00	201.52	10.81			197.99	10.66			194.41	18.24				
Barium	8.01	7.58	0.50	0.48	$\bar{X} = 1.001C - 0.36$	8.21	1.21	1.11	$\bar{X} = 0.995C + 0.37$	8.04	2.60	2.24	$\bar{X} = 1.055C - 0.21$		
	12.00	11.81	1.05		$S_R = 0.039\bar{X} + 0.31$	12.56	1.79		$S_R = 0.045\bar{X} + 0.97^c$	12.85	1.45		$S_R = 0.020\bar{X} + 2.05$		
	48.00	47.32	1.60	1.82	$S_T = 0.024X + 0.25$	49.13	3.72	3.77	$S_T = 0.040X + 0.72^c$	50.12	2.98	2.19	$S_T = 0.014X + 2.08$		
	64.00	65.52	2.90			65.30	4.16			69.53	2.66				
	160.00	157.09	6.53	4.07		155.25	7.82	5.67		164.44	8.81	6.61			
	200.00	198.53	8.28			196.52	5.70			208.32	9.22				
Beryllium	2.80	3.31	0.81	0.26	$\bar{X} = 1.056C + 0.32$	3.15	0.47	0.31	$\bar{X} = 1.055C + 0.20$	3.02	0.46	0.22	$\bar{X} = 1.049C + 0.08$		
	4.00	4.45	0.73		$S_R = 0.067\bar{X} + 0.55$	4.45	0.51		$S_R = 0.057\bar{X} + 0.28$	4.27	0.44		$S_R = 0.084\bar{X} + 0.16$		
	20.00	22.38	2.76	1.00	$S_T = 0.038X + 0.11$	21.27	1.23	0.63	$S_T = 0.016X + 0.25$	21.55	1.72	1.10	$S_T = 0.043X + 0.06$		
	28.00	30.02	2.86			29.57	1.67			29.24	2.09				
	80.00	84.18	4.79	4.02		87.59	6.89	1.88		84.23	9.05	4.32			
	100.00	102.88	5.90			102.64	6.27			103.39	10.17				
Cadmium	4.00	4.01	0.34	0.20	$\bar{X} = 1.007C + 0.07$	4.11	0.88	0.71	$\bar{X} = 0.985C + 0.10$	3.98	0.48	0.14	$\bar{X} = 0.944C + 0.11$		
	6.00	6.32	0.49		$S_R = 0.041\bar{X} + 0.19$	5.87	0.58		$S_R = 0.031\bar{X} + 0.65$	5.62	0.73		$S_R = 0.017\bar{X} + 1.09^a$		
	20.00	19.81	1.12	0.86	$S_T = 0.022X + 0.10^c$	19.57	1.45	1.26	$S_T = 0.021X + 0.61$	18.15	1.73	0.88	$S_T = 0.029X + 0.01$		
	28.00	28.33	0.94			27.68	1.27			26.86	2.59				
	80.00	81.28	4.91	1.33		80.62	4.45	2.02		77.83	3.05	1.88			
	100.00	100.11	3.24			98.15	3.60			95.31	2.04				

TABLE 12: SUMMARY STATISTICS AND DESCRIPTIVE EQUATIONS FOR THE 20 ANALYTES TESTED IN THE COLLABORATIVE STUDY

Analyte	Reagent Water					Finished Drinking Water				Ground Water			
	C ^a	\bar{X}^b	S _R	S _t	Regr. Equations	\bar{X}	S _R	S _t	Regr. Equations	\bar{X}	S _R	S _t	Regr. Equations
Chromium	8.00	8.27	0.32	1.54	$\bar{X} = 1.017C + 0.62$	9.46	2.34	2.08	$\bar{X} = 0.990C + 1.45$	8.98	1.47	0.37	$\bar{X} = 1.026C + 0.89$
	12.00	13.88	3.10		$S_R = 0.066\bar{X} + 0.48$	13.10	2.39		$S_R = 0.015\bar{X} + 2.19$	13.42	1.13		$S_R = 0.067\bar{X} + 0.68$
	56.00	57.86	4.03	2.68	$S_t = 0.026\bar{X} + 1.25$	56.04	2.24	1.29	$S_t = 2.18^d$	59.35	5.99	5.42	$S_t = 0.068\bar{X} - 0.37$
	80.00	84.73	2.65			84.38	3.18			83.90	5.70		
	160.00	157.66	13.62	6.97		158.24	5.12	3.16		164.58	14.11	9.80	
	200.00	197.43	9.47			196.72	7.47			199.88	11.19		
Cobalt	0.80	0.88	0.10	0.05	$\bar{X} = 0.977C + 0.01$	0.92	0.45	0.31	$\bar{X} = 0.964C + 0.06$	0.85	0.13	0.09	$\bar{X} = 0.989C - 0.01$
	1.21	0.98	0.04		$S_R = 0.028\bar{X} + 0.06$	1.02	0.10		$S_R = 0.019\bar{X} + 0.32$	1.04	0.18		$S_R = 0.057\bar{X} + 0.09$
	20.10	20.77	0.74	0.67	$S_t = 0.027\bar{X} + 0.02$	20.45	0.91	0.53	$S_t = 0.014\bar{X} + 0.30$	20.81	1.11	1.12	$S_t = 0.012\bar{X} + 0.40^e$
	28.20	27.75	0.96			27.29	1.22			28.07	2.16		
	80.50	78.59	2.29	2.31		78.04	3.72	1.84		79.26	4.66	1.34	
	101.00	98.79	2.94			97.62	4.62			99.41	4.22		
Copper	4.00	3.88	0.73	0.59	$\bar{X} = 1.003C - 0.05$	3.33	0.85	0.99	$\bar{X} = 0.976C - 0.38$	3.86	1.40	0.71	$\bar{X} = 0.977C - 0.01$
	6.00	6.14	1.00		$S_R = 0.037\bar{X} + 0.64$	5.95	1.78		$S_R = 0.063\bar{X} + 0.86$	5.96	0.95		$S_R = 0.073\bar{X} + 0.92$
	20.00	20.07	1.08	0.92	$S_t = 0.016\bar{X} + 0.51$	18.90	1.64	1.51	$S_t = 0.029\bar{X} + 0.86$	18.97	1.68	2.32	$S_t = 0.077\bar{X} + 0.35$
	28.00	27.97	1.94			27.21	2.76			27.44	2.58		
	80.00	79.80	3.22	1.91		76.64	5.30	3.42		79.30	9.05	6.54	
	100.00	99.57	4.42			96.17	5.64			97.54	11.16		
Lead	4.00	4.00	1.57	1.62	$\bar{X} = 1.043C - 0.31$	3.44	1.15	1.18	$\bar{X} = 1.032C - 0.30$	4.20	1.13	1.76	$\bar{X} = 1.012C + 0.15$
	6.00	5.56	2.00		$S_R = 0.064\bar{X} + 1.43^c$	6.84	1.10		$S_R = 0.015\bar{X} + 1.06$	6.27	2.38		$S_R = 0.048\bar{X} + 1.27$
	20.00	20.54	2.91	4.36	$S_t = 3.42^d$	20.18	1.20	1.44	$S_t = 0.011\bar{X} + 1.13$	19.57	2.72	0.88	$S_t = 1.78^d$
	28.00	30.90	4.58			28.08	1.57			28.55	1.73		
	80.00	80.57	3.13	4.29		80.92	2.30	2.07		82.47	4.38	2.69	
	100.00	102.93	6.62			101.60	3.23			102.47	3.58		
Manganese	0.80	0.86	0.15	0.09	$\bar{X} = 0.983C + 0.02$	0.96	0.32	0.42	$\bar{X} = 0.989C + 0.10$	0.64	0.22	0.17	$\bar{X} = 0.954C - 0.16$
	1.20	1.09	0.12		$S_R = 0.026\bar{X} + 0.11$	1.13	0.38		$S_R = 0.047\bar{X} + 0.29$	0.90	0.21		$S_R = 0.103\bar{X} + 0.14$
	20.00	20.43	0.89	0.72	$S_t = 0.027\bar{X} + 0.06$	21.06	1.32	0.96	$S_t = 0.021\bar{X} + 0.40$	19.61	2.60	2.62	$S_t = 0.025\bar{X} + 0.09^e$
	28.00	27.53	0.41			27.60	1.47			25.65	4.10		
	80.00	79.00	3.16	2.38		79.57	4.18	2.01		77.38	6.13	2.90	
	100.00	97.60	2.51			97.97	4.10			95.86	6.74		

TABLE 12: SUMMARY STATISTICS AND DESCRIPTIVE EQUATIONS FOR THE 20 ANALYTES TESTED IN THE COLLABORATIVE STUDY

Analyte	Reagent Water				Finished Drinking Water				Ground Water				
	C ^a	\bar{X}^b	S _R	S _T	Regr. Equations	\bar{X}	S _R	S _T	Regr. Equations	\bar{X}	S _R	S _T	Regr. Equations
Molybdenum	2.80	2.63	0.32	0.16	$\bar{X} = 1.012C - 0.20$	2.80	0.20	0.32	$\bar{X} = 1.013C - 0.07$	3.00	0.47	0.42	$\bar{X} = 1.032C - 0.09$
	4.00	3.85	0.31		$S_R = 0.032X + 0.22$	3.95	0.47		$S_R = 0.037X + 0.17$	3.60	0.90		$S_R = 0.55X + 0.43$
	20.00	19.75	0.64	0.64	$S_T = 0.021X + 0.09$	19.78	0.60	1.16	$S_T = 0.035X + 0.20$	20.69	1.37	1.11	$S_T = 0.042X + 0.27$
	28.00	27.87	1.07			27.87	1.51			28.80	2.01		
	80.00	83.07	3.07	1.78		85.65	3.50	3.07		84.26	4.13	4.81	
100.00	100.08	4.32			99.06	2.89			103.57	6.10			
Nickel	4.00	4.02	0.41	0.50	$\bar{X} = 1.000C + 0.12$	3.66	0.53	1.03	$\bar{X} = 0.953C - 0.19$	4.81	2.06	2.82	$\bar{X} = 1.022C + 0.66$
	6.00	6.36	0.91		$S_R = 0.051X + 0.31$	5.44	1.32		$S_R = 0.046X + 0.56$	6.67	3.66		$S_R = 0.091X + 2.03$
	20.00	19.93	1.30	0.63	$S_T = 0.017X + 0.40$	18.42	0.87	1.11	$S_T = 0.023X + 0.91$	20.58	3.71	2.37	$S_T = 0.008X + 2.75^c$
	28.00	28.02	1.25			27.09	1.68			30.73	3.75		
	80.00	79.29	2.95	2.55		75.84	4.40	3.94		82.71	9.49	5.42	
100.00	100.87	7.20			95.83	4.41			101.00	9.89			
Selenium	32.00	33.54	4.63	1.57	$\bar{X} = 1.036C - 0.06$	32.57	4.37	3.65	$\bar{X} = 1.022C + 0.14$	32.46	4.95	3.24	$\bar{X} = 1.045C - 0.83$
	40.00	41.03	6.04		$S_R = 0.051X + 3.24$	42.18	3.71		$S_R = 0.056X + 2.10$	41.46	3.30		$S_R = 0.037X + 2.97$
	80.00	81.40	5.86	5.44	$S_T = 0.061X - 0.64$	79.97	6.66	5.28	$S_T = 0.040X + 2.15$	81.63	6.94	5.65	$S_T = 0.058X + 1.02$
	96.10	98.34	8.57			94.94	7.90			98.92	4.39		
	160.00	163.58	15.69	9.86		163.48	9.17	10.06		167.54	8.69	12.98	
200.00	214.30	10.57			212.19	16.49			209.21	14.65			
Silver	0.80	0.93	0.09	0.14	$\bar{X} = 0.917C + 0.26$	0.70	0.34	0.34	$\bar{X} = 0.888C + 0.09$	0.70	0.26	0.10	$\bar{X} = 0.858C - 0.00$
	1.20	1.51	0.23		$S_R = 0.196X - 0.09$	1.37	0.33		$S_R = 0.186X + 0.17$	0.98	0.28		$S_R = 0.169X + 0.14$
	48.00	49.39	3.25	1.81	$S_T = 0.053X + 0.08$	45.43	6.78	5.15	$S_T = 0.164X + 0.18$	45.59	4.27	2.70	$S_T = 0.120X - 0.01$
	64.00	63.54	2.75			60.35	2.22			59.71	6.58		
	160.00	136.42	48.31	12.19		119.06	55.28	36.34		121.43	42.55	28.19	
200.00	153.74	57.34			172.15	31.92			160.69	27.15			
Thallium	2.80	2.89	0.23	0.22	$\bar{X} = 0.984X + 0.08$	2.88	0.40	0.16	$\bar{X} = 1.010C + 0.01$	2.88	0.14	0.12	$\bar{X} = 1.023C - 0.06$
	4.00	3.92	0.15		$S_R = 0.035X + 0.09$	3.96	0.21		$S_R = 0.040X + 0.21$	3.88	0.37		$S_R = 0.056X + 0.04$
	20.00	19.27	0.99	0.67	$S_T = 0.027X + 0.13$	19.77	1.13	0.83	$S_T = 0.039X + 0.02$	20.22	1.05	0.65	$S_T = 0.049X - 0.06$
	28.00	28.08	0.83			27.61	1.24			28.65	1.50		
	80.00	81.29	3.65	2.86		85.32	4.08	4.05		83.97	6.10	6.05	
100.00	96.69	2.86			100.07	4.33			101.09	4.15			
Thorium	0.80	0.93	0.16	0.09	$\bar{X} = 1.013C + 0.08$	0.78	0.13	0.07	$\bar{X} = 1.019C - 0.06$	0.87	0.17	0.07	$\bar{X} = 1.069C - 0.03$
	1.20	1.22	0.19		$S_R = 0.036X + 0.13$	1.09	0.19		$S_R = 0.035X + 0.12$	1.15	0.17		$S_R = 0.041X + 0.13$
	20.00	20.88	0.90	0.71	$S_T = 0.025X + 0.07$	21.66	0.94	0.54	$S_T = 0.024X + 0.05$	21.78	0.90	0.94	$S_T = 0.027X + 0.04$
	28.00	27.97	1.11			28.09	0.83			29.86	1.65		
	80.10	81.14	2.99	2.14		79.99	2.03	2.60		86.00	3.43	1.95	
100.00	102.64	3.39			100.50	4.56			107.35	4.72			

TABLE 12: SUMMARY STATISTICS AND DESCRIPTIVE EQUATIONS FOR THE 20 ANALYTES TESTED IN THE COLLABORATIVE STUDY

Analyte	Reagent Water				Finished Drinking Water				Ground Water				
	C ^a	\bar{X}^b	S _R	S _T	Regr. Equations	\bar{X}	S _R	S _T	Regr. Equations	\bar{X}	S _R	S _T	Regr. Equations
Uranium	0.80	0.86	0.05	0.08	$\bar{X} = 1.026C - 0.02$	0.85	0.15	0.09	$\bar{X} = 1.026C - 0.04$	0.84	0.23	0.19	$\bar{X} = 1.058C - 0.06$
	1.20	1.10	0.11		$S_R = 0.048\bar{X} + 0.02$	1.05	0.13		$S_R = 0.044\bar{X} + 0.11$	1.10	0.14		$S_R = 0.039\bar{X} + 0.17$
	20.10	21.38	0.99	0.82	$S_T = 0.027\bar{X} + 0.05$	22.30	1.40	0.46	$S_T = 0.022\bar{X} + 0.07$	21.56	1.11	1.08	$S_T = 0.028\bar{X} + 0.16$
	28.10	28.36	1.10			28.89	1.47			29.86	1.83		
	80.30	82.47	4.03	2.16		80.31	2.00	2.71		85.01	3.76	2.00	
	100.00	103.49	5.24			100.70	5.30			106.47	3.74		
Vanadium	32.00	31.02	2.68	2.19	$\bar{X} = 1.025C - 2.21$	33.15	2.51	2.28	$\bar{X} = 1.022C - 0.30$	33.25	3.83	1.87	$\bar{X} = 1.076C - 1.87$
	40.00	38.54	2.94		$S_R = 3.79^d$	40.20	1.88		$S_R = 0.023\bar{X} + 1.45$	40.34	3.08		$S_R = 0.033\bar{X} + 2.25$
	80.00	79.14	4.94	4.29	$S_T = 3.26^d$	77.83	4.18	2.75	$S_T = 0.023\bar{X} + 1.38$	84.42	3.97	2.93	$S_T = 0.049\bar{X} - 0.09$
	96.00	93.47	3.85			96.32	1.34			98.70	5.03		
	160.00	162.43	5.67	3.30		161.89	7.63	6.56		170.94	9.09	11.55	
	200.00	208.20	2.65			214.91	5.89			217.90	11.36		
Zinc	8.00	8.33	2.56	1.78	$\bar{X} = 1.042C + 0.87$	11.60	6.18	5.72	$\bar{X} = 0.943C + 2.54$	7.29	1.12	2.20	$\bar{X} = 0.962C + 0.07$
	12.00	15.49	4.18		$S_R = 0.041\bar{X} + 2.60$	10.21	4.96		$S_R = 0.048\bar{X} + 5.27$	12.66	3.24		$S_R = 0.093\bar{X} + 0.92$
	56.00	56.07	2.91	2.47	$S_T = 0.030\bar{X} + 1.42$	56.83	7.66	4.56	$S_T = 0.004\bar{X} + 5.66^e$	54.86	5.12	7.24	$S_T = 0.069\bar{X} + 1.55$
	80.00	85.53	5.81			82.88	8.34			78.62	8.56		
	160.00	165.17	7.78	9.87		156.69	17.01	9.48		150.12	12.52	10.84	
	200.00	207.27	14.61			191.59	17.21			184.37	16.59		

^a True Value for the concentration added (µg/L)

^b Mean Recovery (µg/L)

^c COD_r < 0.5 - Use of regression equation outside study concentration range not recommended.

^d COD_r < 0 - Mean precision is reported.

^e COD_r < 0 - Unweighted linear regression equation presented.

TABLE 13: BACKGROUND AND SPIKE MEASUREMENTS IN WASTEWATER DIGESTATE^a

	Background		Concentrate 1					Concentrate 2					
	Conc. µg/L	Std Dev µg/L	Spike µg/L	Found µg/L	Std Dev µg/L	% Rec %	RSD %	Spike µg/L	Found µg/L	Std Dev µg/L	% Rec %	RSD %	RSD_r %
Be	0.0	0.0	100	94.5	11.8	94.5	12.5	125	118.1	14.7	94.5	12.4	3.5
Al	78.2	12.4	200	260.9	41.2	91.4	15.8	250	309.1	48.5	92.4	15.7	2.7
Cr	19.5	8.1	200	222.2	23.3	101.4	10.5	250	274.3	26.6	101.9	9.7	2.0
V	1.9	2.8	250	271.8	36.5	108.0	13.4	200	219.3	30.1	108.7	13.7	2.6
Mn	296.6	24.7	125	419.0	35.7	97.9	8.5	100	397.4	34.8	100.8	8.8	1.0
Co	2.5	0.4	125	124.7	12.3	97.8	9.9	101	100.7	9.4	97.2	9.3	2.8
Ni	47.3	5.0	125	161.7	4.9	91.5	3.0	100	142.7	5.6	95.4	3.9	2.1
cu	77.4	13.2	125	194.5	29.5	93.7	15.2	100	172.3	26.6	94.9	15.4	2.2
Zn	77.4	4.9	200	257.4	16.3	90.0	6.3	250	302.5	21.1	90.0	7.0	1.8
As	0.8	1.1	200	194.9	8.0	97.1	4.1	250	244.7	12.8	97.6	5.2	3.4
Se	4.5	6.2	250	236.8	14.2	92.9	6.0	200	194.3	9.3	94.9	4.8	3.8
Mo	166.1	9.4	100	269.8	19.0	103.7	7.0	125	302.0	18.0	108.7	6.0	1.5
Ag	0.6	0.7	200	176.0	14.6	87.7	8.3	250	214.6	17.8	85.6	8.3	2.3
Cd	2.7	1.1	125	117.0	4.8	91.4	4.1	100	96.6	3.2	93.9	3.3	2.9
Sb	3.3	0.2	100	100.2	4.8	96.9	4.8	125	125.9	4.3	98.1	3.4	1.8
Ba	68.6	3.3	250	321.0	19.4	101.0	6.0	200	279.3	17.2	105.4	6.2	2.5
Tl	0.1	0.1	100	103.3	8.0	103.2	7.7	125	129.2	8.9	103.3	6.9	2.1
Pb	6.9	0.5	125	135.1	7.8	102.6	5.8	100	110.3	6.3	103.4	5.7	1.8
Th	0.1	0.1	125	140.2	19.5	112.1	13.9	100	113.3	15.4	113.2	13.6	2.7
U	0.4	0.2	125	141.2	19.3	112.6	13.7	100	113.6	16.0	113.2	14.1	2.5

^aResults from 10 participating laboratories. Wastewater digestate supplied with the study materials. Mean background concentrations determined by the participants.

TABLE 14: SPIKE MEASUREMENTS IN PARTICIPANTS WASTEWATER^a

	Concentrate 1					Concentrate 2					
	Spike µg/L	Found µg/L	Std Dev µg/L	% Rec %	RSD %	Spike µg/L	Found µg/L	Std Dev µg/L	% Rec %	RSD %	RSD _r %
Be	101	103.4	12.0	103.4	11.6	125	128.2	13.6	102.6	10.6	2.4
Al	200	198.7	23.9	99.4	12.0	250	252.4	15.5	101.0	6.1	2.9
Cr	200	205.4	12.3	102.7	6.0	250	253.4	15.4	101.4	6.1	1.1
V	250	246.5	4.4	98.6	1.8	200	196.8	2.8	98.4	1.4	2.0
Mn	125	119.0	5.4	95.2	4.5	100	95.5	4.3	95.5	4.5	0.8
Co	125	125.8	7.0	100.6	5.6	101	99.5	5.3	98.5	5.3	1.8
Ni	125	127.4	9.7	101.9	7.6	100	101.0	7.5	101.0	7.4	1.7
cu	125	126.8	5.3	101.4	4.2	100	105.3	3.6	105.3	3.4	2.8
Zn	200	201.4	36.7	100.7	18.2	250	246.4	29.7	98.6	12.1	2.6
As	200	207.3	11.9	103.7	5.7	250	263.0	2.6	105.2	1.0	3.2
Se	250	256.8	26.4	102.7	10.3	200	214.0	18.7	107.3	8.7	3.6
Mo	100	98.6	4.6	98.6	4.7	125	123.2	6.7	98.6	5.4	2.2
Ag	200	200.7	48.9	100.4	24.4	250	231.2	63.5	92.5	27.5	8.2
Cd	125	123.2	11.5	98.6	9.3	100	95.8	2.9	95.8	3.0	5.8
Sb	100	92.2	4.4	92.2	4.8	125	119.0	1.0	95.2	0.8	2.8
Ba	250	245.2	12.8	98.1	5.2	200	204.7	12.1	102.4	5.9	2.1
Tl	100	100.0	0.9	100.0	0.9	125	128.0	6.0	102.4	4.7	3.5
Pb	125	125.8	5.1	100.6	4.1	100	100.8	2.7	100.8	2.7	2.2
Th	125	124.2	7.6	99.4	6.1	100	99.8	5.7	99.8	5.7	3.2
U	125	130.4	10.3	104.3	7.9	100	106.4	6.8	106.4	6.4	2.3

^aResults from five participating laboratories. Mean concentrations before spiking are not listed because they varied considerably among the different wastewaters.

Annex XI:

**Recommended Method for the
DETERMINATION OF TOTAL MERCURY IN
MARINE SAMPLES BY THERMAL
DECOMPOSITION AMALGAMATION AND
ATOMIC ABSORPTION SPECTROPHOTOMETRY**



REPORT

Recommended Method for the DETERMINATION OF TOTAL MERCURY IN MARINE SAMPLES BY THERMAL DECOMPOSITION AMALGAMATION AND ATOMIC ABSORPTION SPECTROPHOTOMETRY

IAEA/NAEL

Marine Environmental Studies Laboratory in co-operation with

UNEP/MAP MED POL

December 2012

For further information on this method, please contact:

IAEA-Environment Laboratories
Marine Environmental Studies Laboratory
4a Quai Antoine 1er
MC-98000 Principality of Monaco

Tel. (377) 979 772 72; Fax. (377) 979 772 73

E-mail: NAEL-MESL.Contact-Point@iaea.org

Recommended Method for the
DETERMINATION OF TOTAL MERCURY IN MARINE SAMPLES BY
THERMAL DECOMPOSITION AMALGAMATION
AND ATOMIC ABSORPTION SPECTROPHOTOMETRY

DISCLAIMER

This is not an official IAEA publication. The views expressed do not necessarily reflect those of the International Atomic Energy Agency or its Member States.

The material has not undergone an official review by the IAEA. This document should not be quoted or listed as a reference.

The use of particular designations of countries or territories does not imply any judgment by the IAEA, as to the legal status of such countries or territories, of their authorities and institutions or of the delimitation of their boundaries.

The mention of names of specific companies or products (whether or not indicated as registered) does not imply any intention to infringe proprietary rights, nor should it be construed as an endorsement or recommendation on the part of the IAEA.

Limited Distribution

Reproduced by the IAEA

TABLE OF CONTENTS

1. SCOPE	1
2. PRINCIPLE.....	1
3. SAMPLE PRE-TREATMENT	1
4. REAGENTS	2
5. MATERIAL	2
6. CALIBRATION	3
7. PROCEDURE	4
8. QUALITY CONTROL.....	6
9. CALCULATION OF RESULTS	7
10. EXPRESSION OF RESULTS	8
11. REFERENCES	8

NOTE: This method is not intended to be an analytical training manual. Therefore, this method is written with the assumption that it will be performed by formally trained analytical chemist.

In addition, the IAEA recommended methods are intended to be guidance methods that can be used by laboratories as a starting point for generating their own standard operating procedure. If performance data are included in the method, they shall not be used as absolute QC acceptance criteria.

1. SCOPE

The method hereinafter describes the protocol for the determination of total mercury (inorganic and organic) in sediment and biological material.

By using this method, the total mercury in solid samples can be determined without sample chemical pre-treatment.

The recommended protocol is mainly based on the EPA 7473 method; users are encouraged to consult this document (EPA, 2007).

2. PRINCIPLE

The sample is dried and then chemically decomposed under oxygen in the decomposition furnace. The decomposition products are carried out to the catalytic section of the furnace, where oxidation is completed (halogens and nitrogen/sulfur oxides are trapped). The mercury present in the remaining decomposition products is selectively trapped on an amalgamator. After flushing the system with oxygen, the mercury vapour is released by rapid heating of the amalgamator, and carried through the absorbance cell in the light path of a single wavelength atomic absorption spectrophotometer. The absorbance is measured at 253.7 nm as a function of mercury quantity (ng).

The typical working range is 0.1–500 ng. The mercury vapour is carried through a long (first) and a short path length absorbance cell. The same quantity of mercury is measured twice with different sensitivity resulting in a dynamic range that spans four orders of magnitude.

The typical detection limit is 0.01 ng of mercury.

3. SAMPLE PRE-TREATMENT

The sediment samples are prepared following the recommendations of UNEP (2005);

The marine organisms are prepared following the recommendations of UNEP (1984, 1994).

4. REAGENTS

The reagents used shall meet the purity requirement of the subsequent analysis

4.1. ULTRAPUR WATER (type MilliQ)

4.2. NITRIC ACID 65%

4.3. POTASSIUM DICHROMATE OXIDIZING SOLUTION (10% w/v)

Weight 25 g of $K_2Cr_2O_7$ in 250 ml glass bottle, fill it up to 250 ml with water, and shake until total dissolution of solids. Keep the bottle tightly closed in a double plastic bag, and in an Hg free environment (i.e. laminar flow hood). This solution is stable indefinitely and rarely becomes contaminated.

4.4. COMMERCIAL STANDARD SOLUTION 1000 $\mu\text{g ml}^{-1}$ MERCURY

Use a certified reference material solution; this solution should be accompanied by a certificate stipulating at minimum the traceability of the certified concentration, as well as the expiry date. The density of the solution, or the certified content in mg kg^{-1} should also be defined, to allow for the preparation of the calibration solution by weighing. Stock solutions should be kept at 5°C.

5. MATERIAL

5.1. SOLID MERCURY ANALYZER

Optionally equipped with an auto-sampler.

5.2. ANALYTICAL BALANCE

With a 0.001 g precision at least.

5.3. VOLUMETRIC CONTAINERS

Preferably in Teflon or glass.

5.4. PIPETTES

Some microliter pipettes sized ranging from 50 to 10000 μl are needed. The accuracy and precision of the pipettes used should be checked as a routine every 6 months, and the results obtained should be compared with the individual certificates.

5.5. METAL SPATULA (inox).

5.6. SAMPLE BOAT

Metal or metal alloy. Before measurement, sample boats are cleaned by heating over a flame until constant "red" to remove mercury.

5.7. OXYGEN

It should be of high purity and free of mercury. If there is a possible mercury contamination from oxygen, install a gold mesh filter between the cylinder and the instrument to prevent any mercury from entering the instrument.

6. CALIBRATION

- 6.1. PRIMARY CALIBRATION. This is the calibration of the instrument working range. This calibration is performed initially (usually done by the manufacturer and stored in the instrument), and/or when any significant instrumental parameters are changed (i.e. after maintenance).
- 6.2. PREPARE STANDARD SOLUTIONS of appropriate concentration by dilution of a commercial standard (see 4.4). It is recommended to prepare standard solution in Teflon or glass container, in 1 or 0.5% HNO₃ (see 4.2) and 0.1% (v/v) potassium dichromate (see 4.3). Fresh mercury standard should be prepared daily. Prepare a zero calibration solution using the same quantity of acid and potassium dichromate.
- 6.3. START THE INSTRUMENT according to the manufacturer recommendations.
- 6.4. CLEAN THE SYSTEM. Inject 100 µl of water and start the measurement with the recommended parameters (see 7.1). Repeat the cleaning until the absorbance is below 0.001ABS.
- 6.5. SET THE INSTRUMENT PARAMETERS (see 7.1) for selected volume (usually 100 µl) and inject the zero calibration, at least three measurements should be done. The zero solution serves to correct the amount of mercury in water and reagent used for preparing the calibration curve, hence the important of keeping the injected volume equal at all points of the calibration curve. If the amount of mercury in the zero calibration is high (i.e. more than 0.01 ng), it is recommended to check for contamination sources and to prepare new standard solution with clean acid.
- 6.6. STANDARDS ARE MEASURED from the lowest to the highest at least twice. The maximum relative standard deviation between readings should be 3% (except for zero calibration); if higher it is recommended to carry out more measurements.
- 6.7. EXAMPLE OF AMOUNTS used for recalibration (primary):

First Range:

Standard (ng ml ⁻¹)	1	3	10	30	100	300
Volume injected (µl)	100	100	100	100	100	100
Quantity of Hg (ng)	0.1	0.3	1	3	10	30

Second Range:

Standard ($\mu\text{g ml}^{-1}$)	1	2	3	4	5	6
Volume injected (μl)	100	100	100	100	100	100
Quantity of Hg (ng)	100	200	300	400	500	600

Note: The calibration of the second range might induce problems for subsequent analysis, due to the relatively high quantity of mercury introduced (especially with memory effect). It should be performed only if there is a probability of using it (i.e. measuring samples with high mercury level $> 1\mu\text{g g}^{-1}$). After the reading of the last calibration point, clean the system (see 6.4).

- 6.8. ALTERNATIVE CALIBRATION CURVE can be performed using a solid certified reference material. In this case, weigh accurately a CRM onto a tare sample boat, set up the instrument according to the sample type (see 7.1) and measure the absorbance. The matrix of the CRM should be as similar as possible to the sample of interest. Repeat this procedure with different weights of the CRM and/or with different CRM, to get results in the desired working range.
- 6.9. CONSTRUCT A CALIBRATION CURVE by plotting the absorbance against Nano grams of mercury (this could be done automatically by the software). The type of equation will depend on the levels, as the response is not linear over the entire working range.
- 6.10. DAILY CALIBRATION: calibration performed every day with a minimum number of standards to ensure that the primary calibration is valid. It can be performed by using either liquid standard (see 6.2) or solid certified reference material (CRM) see 6.8. It should be performed in the range of interest, with at least two standards (or matrix CRM) and the results should agree within the acceptance criteria. The acceptance criteria should be set through the use of historical data, but the maximum deviation should not exceed 10%.

7. PROCEDURE

7.1. GENERAL ANALYTICAL PARAMETERS

The analytical parameters will depend on the sample size and matrix, and are instrument specific. It is important to follow the guidelines from the instrument manufacturer. There are three time to set: drying, decomposition and waiting.

Some typical recommended conditions below:

Drying time:

Sample type	Dry (s)	Comments
Liquid	0.7 x injected Volume (μ l)	
Dry inorganic	10	
Organic liquid	50–300	To be optimized ¹
Dry organic (i.e. fat)	50–200	To be optimized ¹
Wet (i.e. fresh)	0.7 x weight x % moisture	Example: 100 mg with 45% moisture $0.7 \times 100 \times 0.45 = 31.5\text{s}$ (35)

¹ In the case of organic, there is a risk of explosion especially with organic liquid; to optimize set the instrument at: 300s dry/ 150s decomposition/ 45s wait, do the measurement and check for possible small explosion, note the time of the phenomenon and add to the drying time 10s more.

Decomposition time:

Sample type	Decomposition (s)	Comments
Liquid	150–400	To be optimized ¹
Solid inorganic	120 + 0.4 x sample (mg)	To be optimized ¹
Solid organic	120	

¹ Set the instrument to XX (see above) dry/ 400s decomposition/ 45s wait, run a sample and observe the results. Decrease the decomposition time by 30s and repeat measurement. Continue until you observe a significant decrease, note that time and add to the decomposition time 30s more.

Waiting time:

It is recommended to use 40–45s, except for long decomposition time (over 200s) when it is beneficial to add 10s of waiting for every 100s of decomposition.

Note: These indications above are recommended by ALTECH (AMA 254).

7.2. ANALYSIS OF A SOLID SAMPLE

Weight a sample accurately onto a tare boat, insert the boat into the instrument, set the appropriate parameters (see 7.1) and start the measurements. The results can be records on absorbance, quantity or concentration depending on the instrument software. See 9: Calculation of results.

7.3. ANALYSIS OF BLANK FOR SOLID MEASUREMENT

Analyse an empty sample boat using the same instrument settings than for the sample.

7.4. ANALYSIS OF A LIQUID SAMPLE

Dose a known volume of the sample onto a sample boat, set the appropriate parameters (see 7.1) and start the measurements. The results can be records on absorbance, quantity or concentration depending on the instrument software. See the calculation section (see 9).

7.5. ANALYSIS OF BLANK FOR LIQUID

Repeat 7.4 with the same volume of blank solution (solution that contain the same reagent and chemical than the sample).

8. QUALITY CONTROL

8.1. For every day of analysis, the CALIBRATION SHOULD BE VALIDATED by doing a daily calibration (see 6.10) before starting the measurements. The results of the daily calibration should be recorded for quality control purposes.

8.2. CERTIFIED REFERENCE MATERIAL

At least one certified reference material of a representative matrix should be measured with each batch of the sample, the calculated results should fall in the value of the certificate and within the coverage uncertainty (Linsinger, 2010), to show evidence of unbiased results. The results for the CRM should be recorded for quality control purpose and plotted in a control chart (UNEP/IOC/IAEA 1994).

8.3. A DUPLICATE OR TRIPLICATE SAMPLE should be processed on a routine basis.

A duplicate sample should be processed with each analytical batch or for every 10 samples.

8.4. A SPIKED SAMPLE should also be included, whenever a new sample matrix is being analysed, especially if no certified reference material is available for that matrix. Measure a spiked sample by adding a known volume of standard solution (prepared as in paragraph 6.2) to the sample in the boat. Keep the spike volume small enough not to overspill. The recovery of spike calculated with the equation 2 should be 85–115% (this limits should be reset after collection of historical data). If the test fails, it is recommended to check the calibration (see 6.10) and/or to revise the instrument parameters (see 7.1).

$$\text{Spike (ng)} = \text{Concentration of standard (ng/ml)} \times \text{Volume of spike (ml)} \quad \text{Equation 1}$$

$$\text{Recovery (\%)} = \frac{\text{Spiked sample (ng)} - \text{Unspiked sample (ng)}}{\text{Spike (ng)}} \times 100 \quad \text{Equation 2}$$

To be valid the quantity of Spike (equation 1) should be in the range of 50–150% the quantity of unspiked sample.

9. CALCULATION OF RESULTS

9.1. SOLID SAMPLE RESULTS are calculated using equation 3

$$w(Hg) = \frac{(\rho_1 - \rho_0)}{m} \times R \quad \text{Equation 3}$$

Where:

w(Hg) is the mass fraction of element m in the sample, expressed in mg kg⁻¹;

ρ₁ is the quantity of mercury, expressed in ng as measured in the sample;

ρ₀ is the quantity of mercury expressed in ng as measured in the blank (see 7.3);

R is the recovery calculated using the CRM (see 8.2) or spike (see 8.4);

m is the amount of sample in mg.

Note: ρ₁ and ρ₀ are calculated using calibration curve equation (usually done by software).

9.2. LIQUID SAMPLE RESULTS are calculated using equation 4

$$w(Hg) = \frac{(\rho_1 - \rho_0) \times V}{V_i \times m} \times f \times R \quad \text{Equation 4}$$

Where:

w(Hg) is the mass fraction of mercury in the sample, expressed in mg kg⁻¹;

ρ₁ is the quantity of mercury, expressed in ng as measured in the sample solution;

ρ₀ is the quantity of mercury expressed in ng as measured in the blank solution (see 7.4);

R is the recovery calculated using the CRM (see 8.2) or spike (see 8.4);

V_i is the injected volume (should be the same in sample and blank solution) in ml;

m is the amount of sample in mg;

V is the volume of solution in ml;

f is the dilution factor.

Note: ρ₁ and ρ₀ are calculated using calibration curve equation (usually done by software).

10. EXPRESSION OF RESULTS

The rounding of values will depend on the uncertainty reported with the results; in general for this method two or three significant figures should be reported.

The uncertainty component should be reported with all results. (ISO 2005, Nordtest 2004)

Example: $w(\text{Hg}) = 0.512 \pm 0.065 \text{ mg kg}^{-1}$.

11. REFERENCES

- EPA (2007). U.S. Environmental Protection Agency, EPA method 7473, Mercury in solids and solutions by thermal decomposition, amalgamation and atomic absorption spectrophotometry Rev 0, February 2007:

<http://www.epa.gov/osw/hazard/testmethods/sw846/pdfs/7473.pdf>

- ISO (1995). Guide to the expression of uncertainty of measurements International Organisation for Standardization: Geneva

- Linsinger, T. (2010). European Commission - Joint Research Centre, Institute for Reference Materials and Measurements http://www.erm-crm.org/ERM_products/application_notes/application_note_1/Documents/erm_application_note_1_english_rev3.pdf

- Nordtest (2004). Handbook For Calculation Of Measurement Uncertainty In Environmental Laboratories Edition 2 <http://www.nordicinnovation.net/nordtestfiler/tec537.pdf>

- UNEP (2005). UNEP (DEC)/MED WG.282/inf.5/Rev1, Method for sediment sampling and analysis, February 2005, UNEP.

- UNEP/IOC/IAEA (1984). Reference method 7 rev2: Sampling of selected marine organisms and sample preparation for trace metal.

- UNEP/IOC/IAEA (1994). Reference method 57: Quality assurance and good laboratory practice, UNEP, 1994.

Annex XII:

**RECOMMENDED METHOD FOR THE DETERMINATION OF TOTAL MERCURY IN
SAMPLES OF MARINE ORIGIN BY COLD VAPOUR ATOMIC ABSORPTION
SPECTROMETRY**



REPORT

RECOMMENDED METHOD FOR THE DETERMINATION OF TOTAL MERCURY IN SAMPLES OF MARINE ORIGIN BY COLD VAPOUR ATOMIC ABSORPTION SPECTROMETRY

**IAEA/NAEL Marine Environmental Studies Laboratory in co-operation with
UNEP/MAP MED POL**

December 2012

For further information on this method, please contact:

IAEA-Environment Laboratories
Marine Environmental Studies Laboratory
4a Quai Antoine 1er
MC-98000 Principality of Monaco

Tel. (377) 979 772 72; Fax. (377) 979 772 76

E-mail: NAEL-MESL.Contact-Point@iaea.org

RECOMMENDED METHOD ON THE DETERMINATION OF TOTAL MERCURY
IN SAMPLES OF MARINE ORIGIN BY COLD VAPOUR ATOMIC ABSORPTION
SPECTROMETRY

DISCLAIMER

This is not an official IAEA publication. The views expressed do not necessarily reflect those of the International Atomic Energy Agency or its Member States.

The material has not undergone an official review by the IAEA. This document should not be quoted or listed as a reference.

The use of particular designations of countries or territories does not imply any judgment by the IAEA, as to the legal status of such countries or territories, of their authorities and institutions or of the delimitation of their boundaries.

The mention of names of specific companies or products (whether or not indicated as registered) does not imply any intention to infringe proprietary rights, nor should it be construed as an endorsement or recommendation on the part of the IAEA.

Limited Distribution

Reproduced by the IAEA

TABLE OF CONTENT

1. SCOPE.....	1
2. PRINCIPLE	1
3. REAGENT	2
4. MATERIAL	3
5. INTERFERENCES	4
6. SAMPLE PREPARATION.....	5
7. PROCEDURE	6
8. CALCULATION OF RESULTS	10
9. EXPRESSION OF RESULTS	10
10. REFERENCES	10

NOTE: This method is not intended to be an analytical training manual. Therefore, the method is written with the assumption that it will be used by formally trained analytical chemists.

In addition, the IAEA recommended methods are intended to be guidance methods that can be used by laboratories as a starting point for generating their own standard operating procedure. If performance data are included in the method they must not be used as absolute QC acceptance criteria.

1. SCOPE

This method describes a protocol for measurement of total mercury by cold vapour atomic absorption spectrometry (CV-AAS). The method is simple, rapid and applicable to a large number of environmental samples. This method is applicable when the element content in the digested solution is above the method limit (~ 0.15 ng ml⁻¹ depending on instrument). The typical working range is 0.25–100 ng ml⁻¹ for direct injection of cold vapour, using “batch system”; FIAS or amalgamation accessory will give better sensitivity.

2. PRINCIPLE

The sediment or biological samples are mineralized with strong acids. The inorganic mercury is reduced to its elemental form with stannous chloride. The cold mercury vapour is then passed through the quartz absorption cell of an atomic absorption spectrometer (AAS), where its concentration is measured. The light beam of Hg hollow cathode lamp is directed through the quartz cell, into a monochromator and onto a detector that measures the amount of light absorbed by the atomized vapour in the cell. The amount of energy absorbed at the characteristic wavelength is proportional to the concentration of the element in the sample.

3. REAGENT

The reagents used shall meet the purity requirement of the subsequent analysis:

3.1. WATER

Reagent water (referenced also as water in the text) should be free of contamination.

3.2. NITRIC ACID 65%

3.3. HYDROCHLORIC ACID (37%)

3.4. HYDROGEN PEROXIDE

3.5. VANADIUM PENTOXIDE (V_2O_5)

3.6. SILICON ANTI-FOAMING

3.7. HYDROXYLAMINE HYDROCHLORIDE ($NH_2OH.HCl$)

Dissolve 12.0 g of $NH_2OH.HCl$ in 100 ml reagent water. This solution may be purified by the addition of 0.1 ml of $SnCl_2$ solution and purging 1 hour with Hg-free argon.

3.8. POTASSIUM DICHROMATE OXIDIZING SOLUTION (10% w/v)

Weight 25 g of $K_2Cr_2O_7$ in a 250 ml glass bottle, fill it up to 250 ml with water, and shake until total dissolution of the solid. Keep the bottle tightly closed in a double plastic bag, and in an Hg free environment (i.e. laminar flow hood). This solution is stable indefinitely and rarely becomes contaminated.

3.9. $BrCl$ OXIDIZING SOLUTION

Weigh accurately 11 g of $KBrO_3$ and 15 g of KBr into a clean 1 liter glass bottle. Add 200 ml of Milli-Q water; add carefully 800 ml of concentrated HCl . The dilution has to be carried out in a well-ventilated fume hood to prevent exposure to toxic fumes released during dissolution of $KBrO_3$. Keep the bottle wrapped in aluminium foil, tightly closed in a double plastic bag, and in an Hg free environment (i.e. laminar flow hood). This solution is stable indefinitely but can become contaminated.

3.10. STANNOUS CHLORINE SOLUTION 20% (w/v) in 20% (w/v) HCl

Weigh 20 g of $SnCl_2$ in a 100 ml volumetric flask; add 20 ml of concentrated HCl ; dissolve the $SnCl_2$ (if needed heat at $60^\circ C$ for a few minutes on a hot plate); complete to 100 ml with water. This solution might be purified by bubbling with Hg-free argon for 15 minutes. The obtained solution should be clear and transparent, cloudy or yellow solution indicates a bad quality $SnCl_2$. This solution should be prepared fresh every day preferably, if not it should be kept in the fridge.

Note: The concentration of this solution is dependent on the type of accessory use for vapour generation, and can vary between 5 and 30%, the recommendation of the manufacturer

should be followed (i.e. the solution above is recommended for a VGA-70 from Varian). The validity of the solution (i.e. shelf-life) should be defined during method validation.

3.11. COMMERCIAL STANDARD SOLUTION 1000 $\mu\text{g ml}^{-1}$

Use a certified reference material solution; this solution should be accompanied by a certificate stipulating at minimum the traceability of the certified concentration, as well as the expiry date. The density of the solution, or the certified content in mg kg^{-1} should also be defined, to allow for the preparation of the calibration solution by weighing. Stock solutions should be kept at 5°C.

3.12. ARGON

Use of a gas purifier cartridge for removing mercury, oxygen and organic compounds is recommended.

4. MATERIAL

This section does not list the common laboratory glassware.

4.1. ATOMIC ABSORPTION SPECTROPHOTOMETER

Instrument equipped with an appropriate cold vapour generation system and a quartz or glass tube atomizer. Use a hollow cathode lamp or, preferably, an electrodeless discharge lamp (which gives a greater and more stable light intensity), operated at a current recommended for the lamp and by the instrument manufacturer. An AAS system with background correction device is recommended.

4.2. GLASSWARE

All the glassware, polypropylene, or fluorocarbon (PFA or TFM) containers, including the sample bottles, flasks and pipettes tips, should be washed in the following sequence:

- 24 hrs soaking in a laboratory soap (or 10% alcohol);
- followed by 24 hrs soaking in 10% nitric acid;
- followed by 10% soaking in water;
- final rinse in water; and
- drying under a laminar flow hood.

The cleaned items should be kept in a double sealed plastic bag. It is better to avoid storage of low level ($< 5 \text{ ng ml}^{-1}$) solution in plastic, and for this purpose glass or Teflon is recommended.

If it can be documented, through an active analytical quality control program, using spiked samples and method blanks, then certain steps in the cleaning procedure would not be needed for routine samples, those steps may be eliminated from the procedure (i.e. for the levels

measured by flame AAS, some sterile plastic containers are sufficiently free of contamination for certain analytes).

4.3. PIPETTES

Some microliter pipettes size ranging from 50 to 10000 µl are needed. The accuracy and precision of the pipettes used should be checked as a routine every 6 months, and the results obtained should be compared with the individual certificates.

4.4. VOLUMETRIC CONTAINERS of suitable precision and accuracy.

5. INTERFERENCES

- 5.1. IODIDE, GOLD AND SILVER are known interferences for mercury determination by cold vapour. In samples from marine origin (biota or sediment), the levels of those elements are low, and consequently, do not interfere in the measurement process.
- 5.2. WATER VAPOUR (moisture) should be avoided in the measurement cell, always follow the manufacturer's protocol (e.g. use of membrane drying tube, correct position of gas separator...) and check for absence of moisture in the measurement cell.
- 5.3. When using GOLD AMALGAMATION, and with certain batch systems, the excess of oxidant can cause interference or damage the gold amalgamator, it is then recommended to pre-reduce the samples with hydroxylamine ammonium (see 3.7). This is important when using large amount of digested solution in "batch system".
- 5.4. Some samples (i.e. plants or large amount of mussels) might produce FOAM during the reduction reaction. If the amount of foam is important, it can interfere with gas liquid separation, and/or leak in the measurement cell, this phenomenon can be overcome by using silicon anti-foaming inside the gas liquid separator and/or in the "batch" system. Another option is to use vanadium pentoxide during digestion (see 6.4).
- 5.5. REDUCTION of inorganic mercury will induce loss, so it is important to stabilise all the solutions by using a strong oxidant as dichromate or BrCl (see 3.8 or 3.9).

6. SAMPLE PREPARATION

- 6.1. The sample should be prepared according to the recommended method for digestion of marine samples for the determination of trace metal (IAEA, 2011), but before diluting to the final volume (or weight) with water, add an adequate volume of potassium dichromate or BrCl to get the final concentration of 2% or 1% respectively. All the samples from marine origin (sediment or biota) can be prepared using the acid mixture recommended for fish, as Hg is not attached to silicates. For microwave digestion of sample size above 0.8 g, it is strongly recommended to do cold digestion for at least 5 hours and to use a long ramping time (i.e. 25 minutes) to avoid strong reactions in the microwave vessels.
- 6.2. If other trace elements have to be determined in the digested solution prepared according to the recommended method for digestion of marine samples for the determination of trace metal (IAEA, 2011), following the dilution to the final volume or weight, transfer a quantitatively sufficient amount of digested solution (i.e. at least 10 ml) into a separate container (preferably glass or Teflon), and add an oxidising solution 1% (v/v) of BrCl (see 3.9) or 2% (v/v) of potassium dichromate (see 3.8). Record the amount of oxidising solution added in order to calculate the dilution factor (i.e. dilution factor = 1.01 for 0.1 ml of dichromate in 10 ml).
- 6.3. Alternatively, the samples can be digested using a mixture of 5 ml of HNO₃ and 2 ml of H₂O₂ at 90°C for 4 hours on a hot plate. It is recommended to leave the samples in acid at room temperature, for at least 1 hour before heating. The digestion can be performed either in a Teflon or glass closed containers. After cooling, add an adequate volume of potassium dichromate or BrCl to get the final concentration of 2% or 1% respectively, and dilute to the final volume with water (i.e. for 50 ml final volume, add 1 ml of potassium dichromate or 0.5 ml of BrCl solution). This procedure can be used with bigger sample size if needed (i.e. 2 g); in this case, the volume of nitric acid should be increased to obtain a liquid mixture.
- 6.4. In the case that the digested solution produces foam during the reduction process (see 5.4), 45 mg of vanadium pentoxide should be added in the digestion vessels before addition of the acid mixture, then follow either paragraph 6.1 or 6.3.

7. PROCEDURE

7.1. SAMPLE SOLUTION

Use the sample prepared with one option as described in section 6.

7.2. BLANK SOLUTION

Prepare at least two blank solutions with each batch of sample, using the same procedure than for the samples.

7.3. PREPARATION OF CALIBRATION SOLUTIONS

7.3.1. Before each batch of determination, prepare by the appropriate dilution of 1000 $\mu\text{g ml}^{-1}$ stock standard solution (see 3.11), at least 4 standard solutions and one calibration blank solution, covering the appropriate range of the linear part of the curve. The calibration standards and calibration blank should be prepared using the same type of acid and oxidising solution than in the test portion (the final concentration should be similar).

7.3.2. Calibration solutions should be prepared fresh each day.

7.3.3. If the necessary intermediate stock standard solutions can be prepared in 5% nitric acid and 1% BrCl or 2% $\text{K}_2\text{Cr}_2\text{O}_7$, these solutions should be prepared monthly.

7.3.4. All volumetric material (pipettes and containers) should be of appropriate precision and accuracy, if not available standard solution can be prepared by weighing.

7.4. INSTALLATION OF VAPOUR GENERATOR ACCESSORY

7.4.1. Install the accessory according to the manufacturer's instructions. Certain systems (i.e. VGA from Varian) are designed to be used for hydride generation as well, and require in the instructions to aspirate an extra HCl solution, in the case of stannous chlorine reduction this solution is to be replaced by water. It is recommended to separate the systems used for hydride and for SnCl_2 (i.e. use a spare gas liquid separator and Teflon tubing).

7.4.2. Switch on the argon. For on-line system: start the pump, check the aspiration, and verify the gas liquid separator. If needed replace the pump tubing, clean the gas liquid separator by sonication in diluted detergent.

7.4.3. Clean the system by aspirating reagent and 10% nitric acid as a sample for about 10 minutes. For batch system, perform two cycles with 10% nitric acid.

7.4.4. Set up the atomic absorption spectrometer according to the manufacturer's instructions, at the appropriate wavelength, using the appropriate conditions, and with the suitable background correction system in operation.

7.4.5. Optimise the position of the measurement cell to get the maximum signal.

7.4.6. Connect the vapour generation system to the measurement cell.

7.5. CALIBRATION

7.5.1. Adjust the response of the instrument to zero absorbance whilst aspirating water.

NOTE: if the instrument zero reading is more than 0.002 ABS, the system should be clean again and reagent should be checked.

7.5.2. Aspirate the set of calibration solutions in ascending order, and as a zero member, the blank calibration solution. After the last standard, aspirate 10% nitric acid for 1 minute to rinse the system.

NOTE: The calibration curve is automatically plotted by the instrument software. The obtained curve should be linear with $r > 0.995$.

To correct for the instrumental drift, the calibration should be performed every 20 samples or if the calibration verification has failed (see 7.8.1).

7.6. ASPIRATE SAMPLE BLANK (see 7.2) AND SAMPLE SOLUTIONS (see 7.1)

Record their concentrations as calculated by the software using the calibration curve. Rinse the system by aspirating 10% nitric acid for at least 30 s between samples.

7.7. IF THE CONCENTRATION OF THE TEST PORTION EXCEEDS THE CALIBRATION RANGE, dilute the test portion with the blank solution accordingly.

NOTE: After the measurement of high level (or over calibration) sample, measure a sample blank or water to check the absence of memory effect. If necessary, clean the system for 1 minute with 10% nitric acid.

7.8. QUALITY CONTROL SOLUTIONS

The quality control solutions as described below should be measured during the run.

7.8.1. Calibration Verification CV

After the initial calibration, the calibration curve must be verified by the use of initial calibration verification (CV) standard.

The CV standard is a standard solution made from an independent (second source) material, at/or near midrange. This solution as a calibration standard should be prepared using the same type of acid and oxidising solution than in the test portion (the final concentration should be similar).

The acceptance criteria for the CV standard must be $\pm 10\%$ of its true value.

If the calibration curve cannot be verified within the specified limits, the causes must be determined and the instrument recalibrated before the samples are analysed. The analysis data for the CV must be kept on file with the sample analysis.

The calibration curve must also be verified at the end of each analysis batch and/or after every 10 samples. If the calibration cannot be verified within the specified limits, the sample analysis must be discontinued, the causes must be determined and the instrument recalibrated. All samples following the last acceptable test must be reanalysed.

7.8.2. Blank solution (see 7.2)

The maximum allowed blank concentration should be well documented, and if the blank solution exceeds this value all samples prepared along the contaminated blank should be prepared again and reanalysed.

7.8.3. Post digestion spike

Each unknown type of sample should be spiked to check for potential matrix effect.

This spike is considered as a single point standard addition, and should be performed with a minimum dilution factor. The recovery of spike calculated with equation 1 should be 85-115%. If this test fails, it is recommended to run analysis with standard addition method.

Spike solution: mix a fix volume (V1) of the sample solution, and a known volume (V2) of a standard solution with known concentrations (Cstandard).

Unspike solution: mix the same fix volume (V1) of sample solution, and the same volume (V2) of reagent water.

Measure the concentration C (mg l⁻¹) in both solutions on the calibration curve (see 7.6), and calculate recovery as:

$$C_{spike} = \frac{C_{standard} \times V_2}{(V_1 + V_2)} \quad \text{Equation 1}$$

$$R = \frac{C_{Spike\ Solution} - C_{Unspike\ solution}}{C_{spike}} \times 100 \quad \text{Equation 2}$$

To be valid, the concentrations of spiked and unspiked solutions should be in the linearity range of the calibration curve, and the spiked concentration (equation 1) should be in the range of 50-150% of the concentration of the unspiked solution.

7.8.4. Dilution test

If the analyte concentration is sufficiently high (minimally, a factor of 10 above the lower limit of the quantitation following dilution), an analysis of a 1:5 dilution should agree within

$\pm 10\%$ of the original determination. If not, then a chemical or physical interference effect should be suspected, and method of standard addition is recommended.

7.8.5. Certified Reference Material

At least one certified reference material of a representative matrix should be prepared with each batch of sample, the calculated result should fall in the value of the certificate and within the coverage uncertainty (Linsinger, 2010), to show evidence of an unbiased result.

The results for the CRM should be recorded for quality control purpose and plotted on a control chart (UNEP/IOC/IAEA 1994).

An example of sequence order with recommended criteria and actions is given in table 1.

TABLE 1. EXAMPLE OF AN ANALYTICAL SEQUENCE:

Solutions Description	Performance	Action
Calibration blank	< maximum allowed calibration blank value	Stop until resolve
Standard solution 1–4	$r > 0.995$	recalibrate in the linearity range
CV	$\pm 10\%$ of the true value	Stop until resolve
Sample blank	< maximum allowed blank value	
CRM	Fall in the certificate value within coverage uncertainty, or fall within acceptable criteria of the QC chart	Stop until resolve, check Matrix spike and run again with standard addition method if necessary
Matrix Spike	recovery $100\% \pm 15\%$	switch to standard addition, keep records for future analysis of the same matrix
Dilution Test	sample 1 = 5x sample 1 diluted 5x within 10%	switch to standard addition, keep records for future analysis of the same matrix
Unknown Sample 1–10	should \geq standard 1 and \leq standard 4	report as <minimum quantification limit or dilute
CV	$\pm 10\%$ of the true value	Stop until resolve
Unknown Sample 11–20	should \geq standard 1 and \leq standard 4	report as <minimum quantification limit or dilute
Calibration blank	< maximum allowed calibration blank value	Stop until resolve
Standard solution 1–4	$r > 0.995$	recalibrate in the linearity range
CV	$\pm 10\%$ of the true value	Stop until resolve
Etc....		

8. CALCULATION OF RESULTS

Results are calculated using equation 3

$$w(m) = \frac{(\rho_1 - \rho_0)}{m} \times f \times V \times R \quad \text{Equation 3}$$

Where:

w(m) is the mass fraction of element m in the sample, expressed in mg kg⁻¹;

ρ1 is the concentration of element m, expressed in mg/l as measured in the sample solution;

ρ0 is the concentration of element m expressed in mg/l as measured in the blank solution;

F is the dilution factor calculated as follow:

$$f = \frac{\text{final volume}}{\text{initial volume}}$$

or equal to 1 if ρ1 is determined in undiluted solution;

R is the recovery calculated using the CRM (see 7.8.5) or the post digestion spike.

m is the mass of sample in g

V is the volume of solution in ml

9. EXPRESSION OF RESULTS

The rounding of values will depend on the uncertainty reported with the result; in general for this method two or three significant figures should be reported.

Uncertainty component should be reported with all results. (ISO 2005, Nordtest 2004)

Example: w(Hg) = 0.512 ± 0.065 mg kg⁻¹.

10. REFERENCES

- IAEA (2011). IAEA Recommended method on the microwave digestion of marines samples for the determination of trace element content, 2011, *in preparation*, available upon request
- ISO (1995). Guide to the expression of uncertainty of measurements International Organisation for Standardization: Geneva
- Linsinger T. (2010). European Commission - Joint Research Centre, Institute for Reference Materials and Measurements (http://www.erm-crm.org/ERM_products/application_notes/application_note_1/Documents/erm_application_note_1_english_rev3.pdf)

- Nordtest (2004). Handbook For Calculation Of Measurement Uncertainty In Environmental Laboratories Edition 2 <http://www.nordicinnovation.net/nordtestfiler/tec537.pdf>
- UNEP/IOC/IAEA (1994) reference method 57: Quality assurance and good laboratory practice, UNEP, 1994.

Annex XIII:

HELCOM

Manual for marine monitoring in the COMBINE programme
ATTACHMENT 1. TECHNICAL NOTE ON THE DETERMINATION OF TOTAL
MERCURY IN MARINE BIOTA BY COLD VAPOUR ATOMIC ABSORPTION
SPECTROSCOPY

HELCOM Manual for marine monitoring in the COMBINE programme

ATTACHMENT 1. TECHNICAL NOTE ON THE DETERMINATION OF TOTAL MERCURY IN MARINE BIOTA BY COLD VAPOUR ATOMIC ABSORPTION SPECTROSCOPY

1. POSSIBILITIES OF USING COLD VAPOUR ATOMIC ABSORPTION SPECTROMETRY IN TOTAL MERCURY ANALYSIS

The most widely used method for the determination of total mercury in biological tissues is cold vapour atomic absorption spectrometry (CV-AAS), based on a technique elaborated in detail by Hatch and Ott (1968). In this method, (divalent) ionic mercury is reduced to its metallic form (Hg⁰) in acidic solution using a powerful reducing agent. Subsequently, the elemental mercury is volatilized (purged) by a carrier gas and transported into an absorption cell, where the 253.65 nm wavelength absorbance of mercury atoms is measured.

CV-AAS analysis can be performed manually using batch CV-AAS or automatically using flow injection (FI) techniques. FI is a very efficient approach for introducing and processing liquid samples in atomic absorption spectrometry. The FI technique, combined with a built-in atomic absorption spectrometer optimised for mercury determination, reduces sample and reagent consumption, has a higher tolerance of interferences, lower determination limits and improved precision compared with conventional cold vapour techniques.

The efficiency of various flow injection mercury systems has been reported by several groups (Tsalev *et al.*, 1992a, 1992b; Welz *et al.*, 1992; Guo and Baasner, 1993; Hanna and McIntosh, 1995; Kingston and McIntosh, 1995; Lippo *et al.*, 1997). Better sensitivities of both conventional CV-AAS and FI-CV-AAS can be obtained by collecting mercury vapour released from the sample solution on a gold adsorber (Welz and Melcher, 1984). This so-called amalgamation technique eliminates kinetic interferences due to a different vaporization rate or a different distribution function of the elemental mercury between the liquid and the gaseous phases. The amalgamation ability of the gold adsorber must be carefully and regularly checked. Volatile compounds (in particular sulfur-containing compounds) evaporating together with the elemental mercury from the sample solution may deactivate the adsorber surface. This means an increased risk of underestimation, as unknown quantities of mercury are not collected by the adsorber.

2. SAMPLE PRETREATMENT

It is generally agreed that oxidative conversion of all forms of mercury in the sample to ionic Hg(II) is necessary prior to reduction to elemental Hg and its subsequent measurement by CV-AAS. Therefore, the initial procedural step in mercury analysis is a sample pretreatment, which is aimed at liberating the analyte element from its chemical bonding to the organic matrix and thus transforming all of the analyte species into a well-defined oxidation state. For this purpose, a wide variety of combinations of strong acids (HCl, H₂SO₄, HNO₃) and oxidants (H₂O₂, KMnO₄, K₂Cr₂O₇, K₂S₂O₈) have been tested and recommended (Kaiser *et al.*, 1978; Harms, 1988; Vermeiret *et al.*, 1989; Ping and Dasgupta, 1989; Baxter and Frech, 1990; Landi *et al.*, 1990; Navarro *et al.*, 1992; Lippo *et al.*, 1997).

A suitable sample pretreatment, which implies the complete transformation of all organomercury species into inorganic mercury ions, requires the following:

- oxidation mixtures with a high oxidation potential;
- rapid oxidation (usually promoted by high reaction temperatures), preferably in closed systems;

- compatibility with CV-AAS techniques;
- stability of sample solutions during storage (at least short term);
- no formation of solid reaction products.

On-line sample pretreatment is of particular interest in total mercury determinations because it allows reduction of the well-known problems associated with the inherent risk of contamination, and volatilization and adsorption losses. At present, suitable procedures for on-line pretreatment of solid biological samples are lacking. However, several authors (Tsalev *et al.*, 1992a 1992b; Welz *et al.*, 1992; Guo and Baasner, 1993) have demonstrated that microwave digestion coupled with FI-CV-AAS can successfully be applied to the analysis of liquid samples.

3. CONTROL OF CONTAMINATION AND ANALYTE LOSSES

Major difficulties arise due to the mobility and reactivity of mercury and its compounds, respectively, during sample preparation, sample pretreatment, and analysis. Therefore, the stability of samples and standard solutions is of prime importance, and it is advisable to test the stability of typical standard and sample solutions under typical laboratory conditions.

Mercury can disappear from solution due to several mechanisms, including volatilization of mercury compounds, reduction of such compounds followed by volatilization of elemental (metallic) mercury, adsorption on container walls, adsorption onto colloids or particles, incorporation into stable chemical complexes, or incorporation, upon reduction, into stable amalgams.

Thermodynamic considerations of Toribara *et al.* (1970) showed that loss of mercury from a solution containing the element in the monovalent form may occur readily through disproportion and subsequent loss of metallic mercury. Because of the high oxidation potential of the mercury(II)-mercury(I) system, almost any reducing substance could convert some divalent mercury ions into monovalent mercury ions, which then spontaneously disproportionate into mercury(II) and mercury(0). The latter escape as metallic vapour from the solution into the gas phase. Because of the almost impossibility of preventing the introduction of small amounts of reducing substances by reagents or solvents, the more dilute mercury(II) solutions would be less stable and lose mercury more readily. The only practical method for stabilizing such solutions is to add a small excess of an oxidising substance (such as permanganate), which has a higher oxidation potential than the mercury(II)-mercury(I) system.

Similarly, Feldman (1974) concluded from his experiments that solutions with 0.1 µg divalent Hg dm⁻³ in distilled water could be stored in glass vials for as long as five months without deteriorating if the solutions contained 5 % (v/v) HNO₃ and 0.01 % Cr₂O₇²⁻. Storage of such solutions was safe in polyethylene vials for at least 10 days if the solutions contained 5 % (v/v) HNO₃ and 0.05 % Cr₂O₇²⁻. The efficiency of this mixture was probably due to its ability to prevent the hydrolysis of dissolved mercury and prevent its reduction to valencies lower than +2.

4. REDUCING REAGENTS

Tin(II) chloride and sodium tetrahydroborate are predominantly used as reducing reagents for the determination of total mercury by CV-AAS. Sodium tetrahydroborate has been found advantageous for several applications owing to its higher reducing power and faster reaction (Toffaletti and Savory, 1975). In addition, this reductant has been successfully used even in the presence of interfering agents such as iodide and selenium (Kaiser *et al.*, 1978). However, potential interferences can occur from metal ions (e.g., Ag(I), Cu(II), Ni(II)), which are themselves reduced to the metallic state and so may occlude mercury through amalgamation.

Welz and Melcher (1984) showed that sodium tetrahydroborate could more readily attack those organic mercury compounds which were not reduced to metallic mercury by tin(II) chloride.

However, they stated that sodium tetrahydroborate could not be recommended as the reducing reagent for the amalgamation technique. They found that, due to the rather violent reaction with sodium tetrahydroborate, fine droplets of the sample solution were carried by the gas stream and contaminated or deactivated the adsorber surface. Further, they considered even more important the fact that not only mercury but all gaseous hydride-forming elements (e.g., arsenic, antimony, selenium) were volatilized when sodium tetrahydroborate was used as reductant. These hydrides reacted with the adsorber material and deactivated its surface, thus no longer permitting a sensitive and reproducible determination of mercury.

5. INTERFERENCES

Interferences by volatile nitrogen oxides in the determination of mercury by FI-CV-AAS were studied by Rokkjaer et al. (1993). The main symptom of the interference effects was a suppression, broadening or even splitting of the mercury signal. The authors postulated that volatile nitrogen oxides formed as reaction products of nitric acid during sample decomposition scavenged the reducing agent and concomitantly inhibited the reduction of mercury(II). The rate of the reaction of nitrogen oxides with the reducing agent was considered to be so fast that it was consumed before the reduction of mercury was complete. Rokkjaer et al. (1993) demonstrated that the interference could easily be remedied by purging the sample solution with an inert gas prior to the introduction of the reducing agent. Lippo et al. (1997) concluded from their experiments that nitrogen mono- and dioxide, having molecular absorption bands at 253.63 nm and 253.85 nm, respectively, might cause unspecific absorption at the specific mercury wavelength of 253.65 nm, leading to enhanced and broadened mercury signals if not properly compensated for by adequate instrumental background correction.

6. INTERNAL (ROUTINE) QUALITY CONTROL

In order to demonstrate that the analytical method applied is fit for the purpose of the investigations to be carried out, control materials should be regularly analysed alongside the test materials (cf. Chapter B.5 of the Manual).

The control materials - preferably certified reference materials (CRM) - should be typical of the test materials under investigation in terms of chemical composition, physical properties and analyte concentration. Fitness for purpose is achieved if the results obtained from the analysis of the control materials are within the defined limits of permissible tolerances in analytical error (see Chapters B.3.5, B.4.2.5 and B.4.2.5.2b of the Manual).

7. REFERENCES

- Baxter, D., and Frech, W. 1990. Critical comparison of two standard digestion procedures for the determination of total mercury in natural water samples by cold vapour atomic absorption spectrometry. *Analytica Chimica Acta*, 236: 377-384.
- EURACHEM 2003. EURACHEM/CITAC Guide "Traceability in Chemical Measurement" – A guide to achieving comparable results in chemical measurement. S.L.R. Ellison, B. King, M. Rösslein, M. Salit, A. Williams (Eds.), 43 pp.
- Feldman, C. 1974. Preservation of dilute mercury solutions. *Analytical Chemistry*, 46: 99-102.
- Guo, T., and Baasner, J. 1993. Determination of mercury in urine by flow-injection cold vapour atomic absorption spectrometry. *Analytica Chimica Acta*, 278: 189-196.
- Hanna, C., and McIntosh, S. 1995. Determination of total Hg in environmental samples with on-line microwave digestion coupled to a flow injection mercury system (FIMS). *Atomic Spectroscopy*, 16: 106-114.

- Harms, U. 1988: Analytical procedures for mercury, cadmium and lead in biological material. Baltic Sea Environment Proceedings, No. 27C, Part CI, pp. 36-62. Helsinki Commission.
- Hatch, W., and Ott, W. 1968. Determination of sub-microgram quantities of mercury by atomic absorption spectrometry. *Analytical Chemistry*, 40: 2085-2087.
- Kaiser, G., Götz, D., Tölg, G., Knapp, G., Maichin, B., and Spitzzy, H. 1978. Untersuchung von systematischen Fehlern bei der Bestimmung von Hg-Gesamtgehalten im Bereich 10 -5 % in anorganischen und organischen Matrices mit zwei unabhängigen Verbundverfahren. *Fresenius Z. Analytical Chemistry*, 291: 278-291.
- Kingston, K., and McIntosh, S. 1995. Determination of mercury in geological samples by flow injection AAS. *Atomic Spectroscopy*, 16: 115-117.
- Landi, S., Fagioli, F., Locatelli, C., and Vecchietti, R. 1990. Digestion method for the determination of mercury in vegetable matrices by cold vapour atomic absorption spectrometry. *Analyst*, 115: 173-177.
- Lippo, H., Jauhiainen, T., and Perämäki, P. 1997. Comparison of digestion methods for the determination of total mercury in environmental samples by flow injection CV-AAS. *Atomic Spectroscopy*, 18: 102-108.
- Navarro, M., Lopez, M., Lopez, H., and Sanchez, M. 1992. Microwave dissolution for the determination of mercury in fish by cold vapour atomic absorption spectrometry. *Analytica Chimica Acta*, 257: 155-158.
- Ping, L., and Dasgupta, P. 1989. Determination of total mercury in water and urine by gold film sensor following Fenton's Reagent digestion. *Analytical Chemistry*, 61: 1230-1235. Rokkjaer, J., Hoyer, B., and Jensen, N. 1993. Interference by volatile nitrogen oxides in the determination of mercury by flow injection cold vapour atomic absorption spectrometry. *Talanta*, 40: 729-735.
- Toffaletti, J., and Savory, J. 1975. Use of sodium borohydride for determination of total mercury in urine by atomic absorption spectrometry. *Analytical Chemistry*, 47: 2091-2095.
- Toribara, T., Shields, C., and Koval, L. 1970. Behaviour of dilute solutions of mercury. *Talanta*, 17: 1025-1028. Tsalev, D., Sperling, M., and Welz, B. 1992a: On-line microwave sample pre-treatment for hydride generation and cold vapour atomic absorption spectrometry. Part 1. The manifold. *Analyst*, 117: 1729-1733.
- Tsalev, D., Sperling, M., and Welz, B. 1992b. On-line microwave sample pre-treatment for hydride generation and cold vapour atomic absorption spectrometry. Part 2. Chemistry and application. *Analyst*, 117: 1735-1739.
- Vermeir, G., Vandecasteele, C., and Dams, R. 1989. Microwave dissolution for the determination of mercury in biological samples. *Analytica Chimica Acta*, 220: 257-261.
- Welz, B., and Melcher, M. 1984. Picotrace determination of mercury using the amalgamation technique. *Atomic Spectroscopy*, 5: 37-42.
- Welz, B., Tsalev, D., and Sperling, M. 1992. On-Line microwave sample pre-treatment for the determination of mercury in water and urine by flow-injection cold-vapour atomic absorption spectrometry. *Analytica Chimica Acta*, 261: 91-103.

Annex XIV:

**Sample work-up for the analysis of selected chlorinated
hydrocarbons in the marine environment**



UNITED NATIONS ENVIRONMENT PROGRAMME

November 2011

Sample work-up for the analysis of selected chlorinated hydrocarbons in the marine environment

Recommended Methods For Marine Pollution Studies 71

Prepared in co-operation with



NOTE: This recommended method is not intended to be an analytical training manual. Therefore, the method is written with the assumption that it will be used by formally trained analytical chemists. Several stages of this procedure are potentially hazardous; users should be familiar with the necessary safety precautions.

For bibliographic purposes this document may be cited as:

UNEP/IAEA: Sample work-up for the analysis of selected chlorinated hydrocarbons in the marine environment. Reference Methods for Marine Pollution Studies No 71, UNEP, 2011.

PREFACE

The Regional Seas Programme was initiated by UNEP in 1974. Since then, the Governing Council of UNEP has repeatedly endorsed a regional approach to the control of marine pollution and the management of marine and coastal resources and has requested the development of regional action plans. The Regional Seas Programme at present includes thirteen regions and has over 140 coastal States participating in it (1).

One of the basic components of the action plans sponsored by UNEP in the framework of the Regional Seas Programme is the assessment of the state of the marine environment, its resources and the sources and trends of the pollution and its impact on human health, marine ecosystems and amenities. In order to assist those participating in this activity and to ensure that the data obtained through this assessment can be compared on a world-wide basis and thus contribute to the Global Environment Monitoring System (GEMS) of UNEP, a set of Reference Methods and Guidelines for marine pollution studies are being developed as part of a programme of comprehensive technical support which includes the provision of expert advice, reference methods and materials, training and data quality assurance (2). The Methods recommended for adoption by Governments participating in the Regional Seas Programme.

The methods and guidelines are prepared in co-operation with the relevant specialised bodies of the United Nations system as well as other organisations and are tested by a number of experts competent in the field relevant to the methods described.

In the description of the methods and guidelines, the style used by the International Organisation for Standardisation (ISO) has been followed as closely as possible.

The methods and guidelines published in UNEP's series of Reference Methods for Marine Pollution Studies are not considered as definitive. They are planned to be periodically revised taking into account the new developments in analytical instrumentation, our understanding of the problems and the actual need of the users. In order to facilitate these revisions, the users are invited to convey their comments and suggestions to:

Marine Environmental Studies Laboratory
IAEA Environment Laboratories
4, Quai Antoine 1^{er}
MC 98000 MONACO

which is responsible for the technical co-ordination of the development, testing and inter-calibration of Reference Methods.

References:

(1) www.unep.org/regionalseas (2011)

(2) UNEP/IAEA/IOC: Reference Methods and Materials: A Programme of comprehensive support for regional and global marine pollution assessment. UNEP, 1990.

CONTENTS

	Page
1. Scope and field of application	1
2. Principles	1
3. Reagents, solvents, standards	1
3.1. Reagents	1
3.1.1. List of reagents	1
3.1.2. Cleaning of solvents	3
3.1.3. Cleaning of reagents and adsorbents	3
3.1.3.1. Cleaning of reagents	3
3.1.3.2. Cleaning of adsorbents	4
3.2. Apparatus and equipment	4
3.2.1. List of materials	4
3.2.2. Cleaning of glassware	5
4. Sediments	7
4.1. Sampling	7
4.2. Cleaning of extraction thimbles	7
4.3. Extraction of sediment	7
4.3.1. Extraction of freeze-dried samples	7
4.3.2. Extraction of wet samples	7
4.3.3. Example of determination of percent moisture	8
4.4. Concentration of the extract	8
4.5. Extractable organic matter	9
4.6. Clean-up procedure and fractionation	10
4.6.1. Sulphur and sulphur compounds removal	10
4.6.2. Fractionation	11
4.6.2.1. Florisil	11
4.6.2.2. Gel permeation chromatography	13
4.6.2.3. Alumina and HPLC (silica column)	13
4.6.2.4. High pressure chromatography	13
5. Biota	14
5.1. Sampling	14
5.2. Cleaning of extraction thimbles	14
5.3. Extraction of tissues	16
5.3.1. Extraction procedure for freeze-dried samples	16
5.3.2. Extraction procedure without freeze-drying	16
5.4. Concentration of the extract	16
5.5. Extractable organic matter (EOM)	16
5.6. Clean-up procedure and fractionation	16
5.6.1. Removal of lipids by concentrated sulphuric acid	16
5.6.2. Fractionation	16
6. Capillary Gas chromatographic determinations	17
6.1. Gas chromatography conditions	17
6.2. Column preparation	17
6.3. Column test	18
6.4. Electron capture detector	19
6.5. Quantification	19
7. Computerized gas chromatography/Mass spectrometry (GC/MS)	20
7.1. Operating conditions	20
7.2. Example of a selected ion monitoring programme useful for quantitative analysis of chlorinated compounds	25
8. Notes on water analysis	25
9. Alternative procedures	25
9.1. Combining sample preparation and extraction for chlorinated and petroleum hydrocarbons	25
9.2. Supercritical fluid extraction (SFE) of marine samples	26
9.3. Microwave assisted extraction for marine samples	28
9.3.1. Sediment	28
9.3.2. Biota	28

10. Data interpretation	29
10.1. DDT	29
10.2. PCBs congeners	29
10.3. Typical profiles of commercial mixtures	30
11. Quality assurance / quality control	31
11.1. Precision	31
11.2. Accuracy	31
11.3. Blanks	31
11.4. Recovery	31
11.5. Archiving and reporting of results	31
12. References	34
 Annex:	
Explanations sent to all laboratories with sets of standard provided by IAEA-EL/MESL.	36

1. SCOPE AND FIELD OF APPLICATION

This reference method is intended for use in monitoring programmes and pilot research studies. The document describes procedures for the isolation of purified fractions amenable for the determination of DDTs and PCBs in marine sediments and marine organisms by capillary GC/ECD. It is assumed that most of the participants in the UNEP Regional Seas Programmes are equipped with advanced high resolution capillary gas chromatographs and will be able to implement most, if not all, of the procedures described in Reference Method No 40, "Determination of DDTs and PCBs by capillary gas chromatography and electron capture detection" (UNEP 1988). Assuming consistent results are routinely being obtained with these methods by the analytical laboratory, the determination of specific compounds (as opposed to generic mixture of PCBs) opens up the possibility not only of identifying environmental "hot spots", but also for characterising sources, elucidating transport pathways and developing data of greater toxicological relevance. The organisation and content of this document, however, deserves further comment. Under the sections devoted to SEDIMENTS and ORGANISMS, subsections are provided relating to procedures for: 1) Sampling, 2) Extraction and 3) Clean-up and fractionation. In each subsection, several alternative procedures are described. These various procedures have been previously tested and are provided to accommodate the range of capabilities in participating laboratories. For example, laboratories which have access to an HPLC may consider the benefits of using HPLC fractionation procedures in lieu of more conventional low pressure column chromatographic method. Participants are generally encouraged to implement the most effective procedures within the constraints of their individual laboratories.

Several other halogenated pesticides and other electron capturing organic compounds may be present in environmental samples and many of these compounds could also be isolated by the methods described here. However, not all residues will be stable to the clean-up procedures applied for the determination of PCBs and DDTs. Consequently, every analyst must test for analyte recovery and analytical reproducibility prior to applying these methods for other analytes on a routine basis. Primary emphasis should be placed on obtaining the cleanest possible purified fraction for capillary GC/ECD analysis so that interferences and misidentification are minimised, if not eliminated.

2. PRINCIPLES

Following collection of sediment or biota samples using appropriate techniques, samples are stored in trace organic free vessels at -20°C until analysis. For analysis, the samples are prepared for solvent extraction. To achieve a satisfactory recovery of the chlorinated hydrocarbons, samples are dried by either desiccation with anhydrous sodium sulphate or by freeze-drying. Lipids are then Soxhlet extracted from sediments using hexane and dichloromethane, and from biota using hexane or petroleum ether. Following initial clean-up treatments (removal of sulphur from sediment extracts and treatment of biota extracts with concentrated sulphuric acid to destroy some interfering lipids), extracts are fractionated using column chromatography. Detailed protocols for absorption chromatographic fractionation are described for both low and high pressure systems, using Florisil and silica gel respectively. (Additional information concerning alternative techniques including gel permeation chromatography is provided).

3. REAGENTS, SOLVENTS, STANDARDS

3.1. Reagents

3.1.1. List of reagents

- Demineralized distilled water produced by distillation over potassium permanganate (0.1 g/l KMnO₄) or equivalent quality, demonstrated to be free from interfering substances.
- Detergent.
- Potassium dichromate.
- HCl. 32%.
- Concentrated H₂SO₄ (d 20°C: 1.84 g/ml).
- Sulfochromic cleaning solution made from concentrated sulphuric acid and potassium

- dichromate.
- KOH.
 - Anhydrous sodium sulphate.
 - Copper fine powder (particle size 63µm).
 - Carborundum boiling chips.
 - Hg.
 - Glass wool
 - Alumina (200-240).
 - Silica gel (60-100).
 - Florisil PR (60-100).
 - Bio-Beads SX-3 (200-400).
 - Sephadex LX-20.

Solvents:

- Hexane, Dichloromethane, Methanol, Pentane, Cyclohexane, Toluene and Ethyl Acetate, all "distilled in glass" quality.

Standards:

- PCB congeners: 29, 30, 121, 198.
- ε HCH.
- Endosulfan Id₄.
- n-C₁₄ d₃₀, n-C₁₉ d₄₀, n-C₃₂ d₆₆.
- Naphthalene d₈.
- Hexamethylbenzene.
- Cadalene: 1, 6-dimethyl-4-(1-methylethyl)naphthalene.
- DDT reference solutions - Prepare a stock solution of the DDT series (pp' DDT, op DDT, pp' DDD, op DDD, pp' DDE, op DDE) by dissolving 50 mg of each compound in 100 ml of hexane. Store stock solution in sealed glass ampoules.
- Other reference solutions - should be prepared if other residues are to be quantified in these procedures.

NOTES:

Working solutions obtained from the stock reference solutions should be prepared on a regular basis depending on their use and stored in clean glass volumetric flasks tightly capped with non-contaminating materials such as Teflon or glass. Extreme care must be taken to ensure that the concentrations of the standards have not altered due to solvent evaporation.

In order to achieve acceptable accuracy for the standard solutions, at least 50 mg of pure individual compound should be weighed and dissolved into 100 ml of hexane. This will give stock solutions of 500ng/µl.

Example of preparation of stock solutions:

Preparation of a stock solution of pp' DDE at approximately 500ng/µl:

The pp' DDE stock solution is prepared by dissolving approximately (but weighed accurately) 50 mg of pp' DDE in hexane in a 100 ml volumetric flask and bringing the volume to exactly 100 ml with hexane. If the actual weight of pp' DDE is 52 mg, then

$$\frac{52 \text{ mg DDE}}{100 \text{ ml solvent}} \times \frac{1000 \mu\text{g}}{\text{mg}} \times \frac{\text{ml}}{1000 \mu\text{l}} = \frac{52 \text{ mg DDE}}{100 \text{ ml of solution}}$$

$$52 \text{ mg}/100 \text{ ml} \Rightarrow 0.52 \text{ mg/ml} \Rightarrow 520 \mu\text{g/ml} \Rightarrow 520 \text{ ng}/\mu\text{l}$$

The concentration of the stock solution will be: 520ng/µl

Preparation of an intermediate solution:

Use the stock solution to prepare the intermediate solution. The concentration of pp' DDE intermediate solution should be approximately 5ng/μl. To prepare the 5ng/μl intermediate solution, transfer 1 ml of the pp' DDE stock solution into a 100 ml volumetric flask and dilute with hexane to 100 ml.

$$\frac{1 \text{ ml DDE stock solution}}{100 \text{ ml final volume}} \times \frac{520 \text{ ng DDE}}{\mu\text{l}} = \frac{5.2 \text{ ng}}{\mu\text{l intermediate solution}}$$

The concentration of the intermediate solution will be: 5.2 ng/μl

Preparation of the working solution:

Use the intermediate solution to prepare the working solution. The concentration of pp' DDE in the working solution could be approximately 50pg/μl.

To prepare the 50 pg/μl working solution, transfer 1 ml of the pp' DDE intermediate solution into a 100 ml volumetric flask and dilute with hexane to 100 ml.

$$\frac{1 \text{ ml DDE intermediate solution}}{100 \text{ ml final volume}} \times \frac{5.2 \text{ ng}}{\mu\text{l}} \times \frac{1000 \text{ pg}}{\text{ng}} = \frac{52 \text{ pg}}{\mu\text{l working solution}}$$

The concentration of the working solution will be: 52 pg/μl

3.1.2. Cleaning of solvents

All reagents, including the distilled water should be of analytical quality. Commercially available solvents like acetone, acetonitrile, dichloromethane, hexane and pentane are invariably contaminated with ECD-active substances; their concentrations vary from batch to batch and with supplier. Reagent quality should be checked by injection of 2 μl of a 100 ml batch of solvent, after concentration to 50 μl in a rotary evaporator. No peak in the GC-ECD chromatogram (90 - 250 °C) should be larger than that for 1pg of lindane. Otherwise, the solvent must be distilled. The following procedure has been found to be both efficient and cost effective, as it allows the use of technical grade solvents as the basic material (reducing the cost by one order of magnitude). 130 - 150 cm height columns are required; the packing material must be glass (to allow subsequent cleaning with an oxidising acid). The entire equipment is cleaned prior to use by 2 consecutive distillation procedures with 500 ml water in each case. It is essential that a current of nitrogen gas (15 ml/min) flows from the distillation flask during distillation of the organic solvents: the condenser serves as exhaust. Ambient air is not in contact with the solvent in this way. Problems are associated with other methods of excluding room air (e.g., active carbon or molecular sieves), the most important one being discontinuity. The condensate is distilled into a 1 litre flask at a 1:20 ratio. This large volume allows for direct transfer into the appropriate solvent containers which should be made of glass and of a sufficient size to provide solvent for not more than 6 analyses. A bottle with sufficient solvent for 10 - 15 analysis has to be opened and closed many times and even when kept closed, when not in use, contamination from the surrounding atmosphere takes place. For more detailed information, consult the Reference Method No 65: UNEP/IOC/IAEA: Reagent and laboratory ware clean-up procedures for low-level contaminant monitoring.

3.1.3. Cleaning of reagents and adsorbents**3.1.3.1. Cleaning of reagents**

Powdered or crystalline reagents, such as anhydrous sodium sulfate (Na₂SO₄)*, potassium hydroxide (KOH), glass wool * and carbon or carborundum boiling chips *, must be thoroughly cleaned before use. They should be extracted with hexane in a Soxhlet apparatus for 8 hours and then with methanol or dichloromethane for another 8 hours. For those items indicated by an *, this will require pre-combustion in a muffle furnace at approximately 400°C.

3.1.3.2. Cleaning of adsorbents

Silica gel, alumina and Florisil have to be solvent extracted. Each reagent is first refluxed with methanol or dichloromethane in a Soxhlet apparatus for 8 hours, then with n-hexane for the same period. The solvent is removed by a rotary evaporator operating at low speed, until the sorbent starts falling down as fine particles. Reagents are dried in a drying oven at 0.01 mbar. If this is not available, they are dried in a normal oven at 120°C for 4 hours. This serves to activate silica and alumina. Florisil has to be activated at 130°C for 12 hours. The sorbent is allowed to cool in the oven (if possible under vacuum to avoid uptake of contaminants from the atmosphere) or alternatively, in a dessicator. As active sorbents attract water and contaminants from the atmosphere, controlled deactivation should be carried out by adding water to the fully active sorbent (5% by weight to silica, 2% by weight to alumina, and 0.5% by weight to Florisil). The deactivation procedure should be carried out by adding the water to the sorbent and mixing by gentle shaking for a few minutes. The equilibration takes one day. The activity can be maintained for longer periods of time by sealing the required amount of sorbent in glass ampoules. Otherwise, the activation/deactivation has to be done the day before use.

3.2. Apparatus and equipment

The laboratory used for organic trace analysis must be a dedicated facility, isolated from other projects that could be sources of contamination. It must be properly constructed with fume hoods and benches with electric sockets that are safe for use with flammable solvents. The laboratory must have extractors and rotary evaporators cooling water to run the stills. In tropical regions and in dry climates, a refrigerated re-circulating system should be used to reduce temperatures to the required levels and/or to conserve water. Stainless steel or ceramic tiles make good non-contaminating surfaces. If necessary, benches can be coated with a hard epoxy resin and walls can be painted with epoxy paint. A sheet of aluminium foil on the workbench provides a surface which can be cleaned with solvent. A vented storage facility for solvents is essential. Benches must be fitted with frames to hold stills, extractors, etc. The emergency cut-off switch should be accessible from both inside and outside the laboratory. Fire fighting equipment should be mounted in obvious places and laboratory personnel trained in their use.

3.2.1. List of materials

- A coring device with liners and plunger or a grab sampler (thoroughly cleaned with detergents and solvents before use).
- Glass jars and aluminium foil, stainless steel knives, scoops, forceps, labels, marking pens, logbook.
- Insulated plastic boxes for transporting samples. Ice or dry ice.
- Deep freezer (-18 to -20°C) for sample preservation (frost free type freezers heat to above zero during frost removal cycles and they cannot be used for long term storage).
- Rotary evaporator.
- Kuderna-Danish (or similar) concentrator and heater.
- Soxhlet extraction apparatus and heaters.
- Glassware including boiling flasks, ground glass stoppers, beakers, Erlenmeyer flasks, separatory funnels, centrifuge tubes, weighing bottles, pipettes, tissue grinders.
- Drying oven (temperature range up to at least 300°C) for determining sample dry weights, baking of contaminant residues from glassware and reagents.

Note: A muffle furnace is better for baking materials at greater than 300°C, if required.

- Centrifuge and tubes.
- Freeze-dryer and porcelain pestle and mortar.
- Analytical balance with an accuracy of 0.1 mg and an electro-balance with an accuracy of at least 1 µg.
- Stainless steel tweezers and spatulas.

- Dessicator - completely free of organic contamination and with no grease applied to sealing edges.
- Supply of clean, dry nitrogen.
- Columns for silica gel, alumina and Florisil chromatography.
- Mechanical blender (food mixer).
- Vacuum pump (water-jet air pump).

3.2.2. Cleaning of glassware

Scrub all glassware vigorously with brushes in hot water and detergent. Rinse five times with tap water and twice with distilled water. Rinse with acetone or methanol followed by hexane or petroleum ether. Bake overnight in an oven at 300 °C. All glassware should be stored in dust free cabinets and tightly sealed with pre-cleaned aluminium foil when not in use. Ideally glassware should be cleaned just before use.

For more detailed information, consult Reference Method No 65: UNEP/IOC/IAEA: Reagent and laboratory ware clean-up procedures for low level contaminant monitoring.

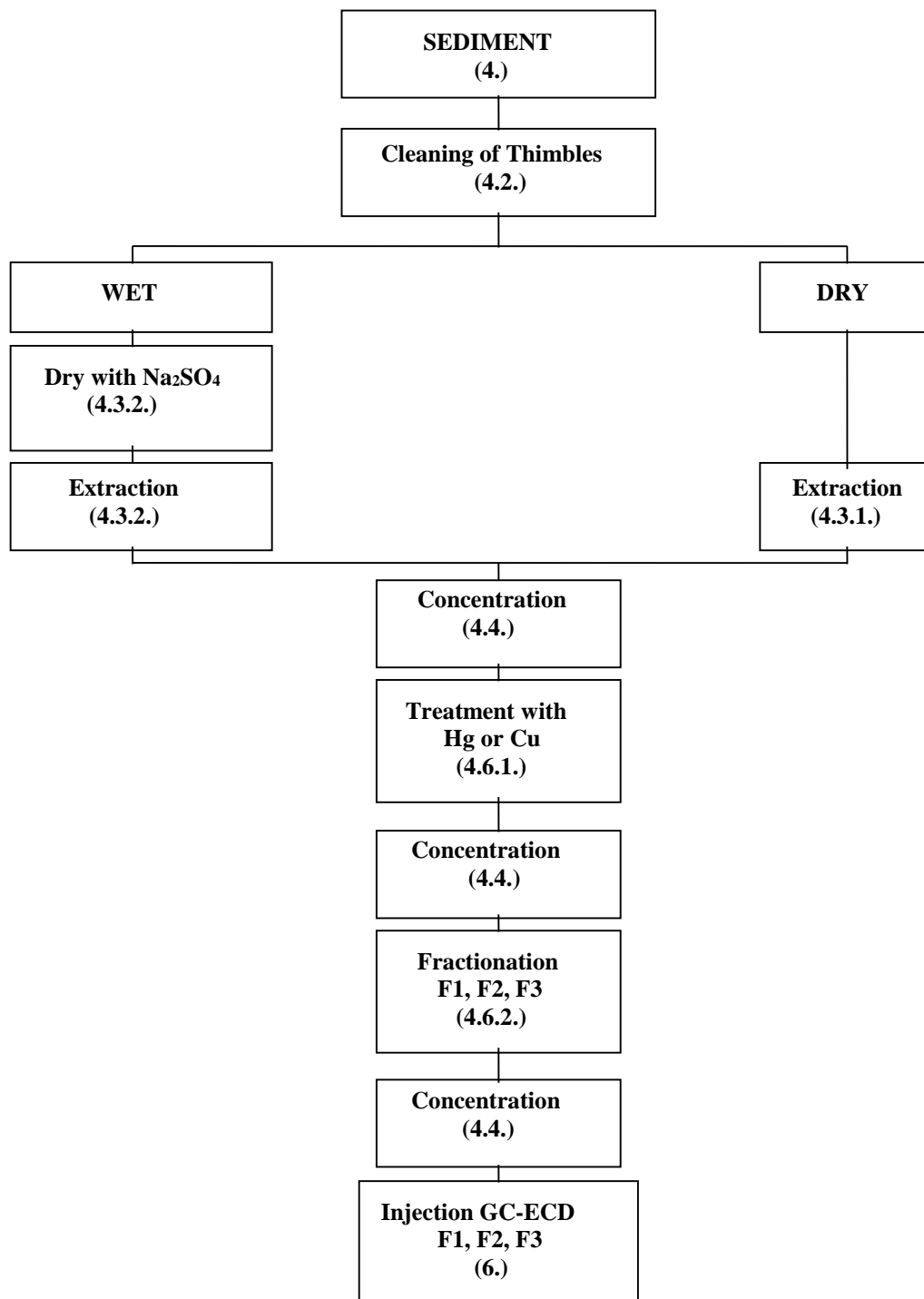

Diagram of the extraction procedure for sediment samples.

4. SEDIMENTS

4.1. Sampling

For the preparation of the samples (including selection of sites, collection of samples and storage) the reader should refer to the Reference Method N° 58: Guidelines for the use of sediments for the marine pollution monitoring programmes, to the Reference Method N° 20: UNEP/IOC/IAEA: Monitoring of petroleum hydrocarbons in sediments and to UNEP(DEC)/MEDW.C282/Inf.5/Rev1: Methods for sediment sampling and analysis (2006).

4.2. Cleaning of extraction thimbles

Paper extraction thimbles should be cleaned prior to sample extraction. For use in the extraction of sediment samples, the extraction can be performed in the Soxhlet apparatus with 250 ml of a mixture hexane / dichloromethane (50:50) for 8 hours cycling the solvent through at a rate of 4 to 5 cycles per hour. Add into the solvent a few carborundum boiling chips to get a regular ebullition.

The use of disposable paper thimbles for the extraction procedure rather than re-usable glass fibre thimbles is recommended due to the difficulties encountered in cleaning the latter.

4.3. Extraction of sediments

4.3.1. Extraction of freeze-dried samples

Select a 50-100 g sub-sample of the sediment, weigh this sub-sample and freeze-dry it. When dried, re-weigh it and calculate the dry to wet ratio. Then pulverise the sample using a pestle and mortar and sieve it using a 250 µm stainless steel sieve. Accurately weigh about 20 g of ground sample and place it in the pre-cleaned extraction thimble. Add 1 ml of a solution of 25 pg/µl of 2,4,5 trichlorobiphenyl (PCB N° 29), 20.9 pg/µl of 2,2',3,3',4,5,5',6 octachlorobiphenyl (PCB N° 198), 20 pg/µl of ε HCH and 21 pg/µl of Endosulfan Id₄ as internal standards and extract for 8 hours in a Soxhlet apparatus with 250 ml of a mixture hexane / dichloromethane (50:50), cycling the solvent through at a rate of 4 to 5 cycles per hour, add into the solvent a few carborundum boiling chips to get a regular ebullition. Alternatively (or in addition), PCB congeners No 30, 121, or octachloronaphthalene and PCB congeners can be used as internal standards. Prepare a procedural blank by extracting an empty thimble using the same procedure as for the samples.

4.3.2. Extraction of wet samples

The sediment is thawed, sieved at 250 µm and homogenised manually with a stainless steel spatula or clean glass rod. A sub-sample of 1-2 g is weighed into a flask and placed in a drying oven at 105 °C for 24 hours, then allowed to cool to room temperature and re-weighed. Calculate the dry to wet ratio and discard the dry sediment (unless it is being used for other analysis e.g. TOC, total organic carbon).

Place a 30-40 g sub-sample of thawed, homogenised sediment into a blender. Slowly, add 100g of anhydrous sodium sulphate (desiccant) and blend the mixture at high speed for 10 minutes. Transfer the dried sample quantitatively to the pre-cleaned extraction thimble in the Soxhlet apparatus, add the internal standard solution (see above) and apply the same extraction procedure as above. Extract the same amount of sodium sulphate as a procedural blank, making sure to add an appropriate amount of internal standard solution.

4.3.3. Example of determination of percent moisture

Many environmental measurements require the results to be reported on a dry weight basis. The percent moisture or water content in the sample is determined by weighing an aliquot, not used for analysis, of the sample before and after drying. The drying can be done by heating a few grams (1-2 g) of the sample in an oven to constant weight.

Weigh an empty glass beaker that will be used to hold the sample while it is dried.

Empty beaker weight = 10.4417 g

Add the wet sample to the beaker and reweigh. Calculate the wet weight of the sample.

Empty beaker weight + wet sample = 12.2972 g

Wet sample weight = 12.2972 g - 10.4417 g = 1.8555 g

Dry the sample to constant weight: dry the sample for 24 hours, weigh it, dry again for 12 hours, re-weigh it, when the difference in weight is less than 5%, it means that the sample is dried.

Empty beaker weight + dry sample weight = 10.9396 g

Dry sample weight = 10.9396 g - Empty beaker weight

Dry sample weight = 10.9396 g - 10.4417 g = 0.4979 g

Calculate the percent dry sample weight.

$$\begin{aligned} \% \text{ Sample weight} &= \frac{\text{Sample dry weight}}{\text{Sample wet weight}} \times 100 \\ &= \frac{0.4979}{1.8555} \times 100 = 26.8 \% \end{aligned}$$

Calculate the percent moisture.

$$\begin{aligned} \text{Water content} &= \text{wet weight} - \text{dry weight} \\ &= 1.855 \text{ g} - 0.4979 \text{ g} = 1.3576 \text{ g} \end{aligned}$$

$$\% \text{ Moisture} = \frac{\text{Sample water weight}}{\text{Sample wet weight}} \times 100$$

$$\% \text{ moisture} = \frac{1.3576}{1.8555} \times 100 = 73.2 \%$$

4.4. Concentration of the extract

For both extraction procedures, the extracts are concentrated in a rotary evaporator to about 15 ml. Under good vacuum conditions the temperature of the water bath must not exceed 30 °C. Dry the extract with anhydrous sodium sulphate (when the sodium sulphate moves freely in the flask it means that the extract is dried). Collect the dried extract in the graduated tube of a Kuderna-Danish concentrator. Concentrate the extract to approximately 5 ml with the Kuderna-Danish concentrator and adjust the volume to exactly 1 ml by evaporating excess solvent under a gentle stream of clean dry nitrogen. The sample extract will be analysed gravimetrically for extractable organic matter (EOM) content at the 1 ml volume as a starting point. If measurements of the EOM are outside the calibration range of the balance, the total volume of the extract is adjusted accordingly using either dilution with hexane or evaporating under a stream of nitrogen gas.

4.5. Extractable organic matter

Before carrying out the clean-up procedure, it is advisable to determine the extractable organic matter.

The EOM is determined in the following manner. On the weighing pan of an electro-balance, evaporate a known volume of the sediment or biota extract (up to 100 µl) and weigh the residue with a precision of about ± 1 µg. If the residue is less than 2 µg, pre-concentration of the original extract is required. The quantity of EOM is:

$$\text{EOM } (\mu\text{g/g}) = \frac{\text{Weight of residue } (\mu\text{g}) \times \text{volume of the extract (ml)} \times 1000}{\text{Volume evaporated } (\mu\text{l}) \times \text{quantity of sample extracted (g)}}$$

Note that extreme care must be taken to ensure balance and pans are clean, dry and stable to obtain accurate readings at the ± 1 µg level. A small hot plate is used to warm pans and forceps and thus keep these instruments dry after solvent cleaning. If no electro-balance is available, a known volume of the extract can be transferred into a clean pre-weighed beaker. The solvent is evaporated with dry and clean nitrogen until a constant weight of about 1 mg is reached. Calculate the amount of “lipids” in the sample taking into account the volume of the lipid extract which was dried.

Example of calculation of E.O.M.

The extractable organic matter content of a sample is operationally defined as the weight of material extracted with the solvent employed (H.E.O.M. in case hexane is used as solvent). An aliquot of the sample extract is taken (few µl), the solvent is evaporated and the residue is weighed to determine the quantity of lipids extracted in the aliquot and from it to the total sample. The results are normally reported in mg lipids per gram dry weight extracted.

A 1 µl aliquot is removed from a 2.5 ml sample extract for determination of E.O.M. The 1 µl aliquot is evaporated on the pan of an electro-balance and the residue is weighed. Three determinations are made and the average taken.

Measurements:

Sample dry weight extracted: 4.443 g

Total volume of the extract: 2.5 ml

Sample aliquot removed: 1 µl

(1) Weight of a 1 µl aliquot after solvent evaporation: 32.2 µg

(2) Weight of a 1 µl aliquot after solvent evaporation: 32.1 µg

(3) Weight of a 1 µl aliquot after solvent evaporation: 32.3 µg

Average weight of a 1 µl aliquot : 32.2 µg

Total volume of the extract: 2.5 ml

Total quantity of lipids in the sample:

$$32.2 \mu\text{g}/\mu\text{l} \times 2.5 \text{ ml} \times \frac{1000 \mu\text{l}}{\text{ml}} = 80500 \mu\text{g} \text{ or: } 80.5 \text{ mg}$$

With 4.443 g of sample extracted:

$$80.5 \text{ mg} / 4.443 \text{ g} = 18.1 \text{ mg lipids/g}$$

4.6. Clean-up procedure and fractionation

Purposes of the clean-up: removal of lipids, whenever present at a significant amount; removal of elementary sulphur and sulphur compounds. Both these compound classes can interfere with the gas-chromatographic separation.

4.6.1. Sulphur and sulphur compounds removal

Elementary sulphur and sulphur compounds such as mercaptans should be removed from the extract. This could be done by using either mercury or activated copper.

a) Mercury method.

Add one drop (a few ml) of mercury to the sediment extract and shake vigorously for one minute. Centrifuge and carefully recover and transfer the extract in another tube with a Pasteur pipette. If the mercury is still tarnished, repeat the treatment with another drop of mercury, shake, transfer the hexane into another tube. Repeat this treatment until the mercury stays brilliant in the extract. Rinse the mercury with 5 ml of hexane and combine the extracts. Then, concentrate the resulting solution to ca. 1 ml with a gentle stream of nitrogen.

Cleaning of mercury:

Caution: When removing mercury from the sample, always use a plastic tray to keep the glassware in and work under a fume hood.

Fit a folded filter paper in a 10 cm diameter conical glass funnel and fix the funnel over a 250 ml glass beaker. Using a needle, make a small hole in the bottom of the filter paper. Carefully put the mercury onto the funnel. The mercury flows through the small hole in the filter paper leaving the solid impurities on its surface. The mercury collected is washed three times by shaking it carefully with dichloromethane and by removing dichloromethane layer with the help of a clean glass syringe. Allow the rest of dichloromethane evaporate and store the clean mercury in a thick walled glass bottle with a ground glass stopper. In order to avoid escape of mercury vapour, store the mercury under methanol.

Another way of cleaning the mercury involves sucking the dirty mercury through a capillary tube, such as a Pasteur pipette, connected to a guard-flask and then to a vacuum pump. The mercury will pass through the Pasteur pipette and will be collected and cleaned in the guard-flask. Then it should be transferred into a thick wall glass bottle with a ground glass stopper. The mercury is covered with a layer of methanol to protect it from oxidation.

b) Activated copper method.

Transfer about 20 grams of the copper powder in an Erlenmeyer. Add enough concentrated HCl to cover the copper powder, agitate. Sonicate for 10 min., agitate, put again in ultrasonic bath and sonicate for 10 min. Throw the used HCl, add some fresh HCl, transfer in ultrasonic bath and sonicate for 20 min. repeat that procedure four times in total. Wash with distilled water, agitate, discard, add water again, transfer in ultrasonic bath and sonicate for 15 min., discard the used water, repeat that procedure again, up to pH neutral. Wash with acetone, agitate, transfer in ultrasonic bath and sonicate for 15 min. repeat that procedure four times in total. Then use the same procedure with hexane as a solvent.

Keep in hexane (use it immediately, avoids Cu to be in contact with air).

Transfer 3 to 4 Pasteur pipettes per sample in the flasks containing the hexane extracts. Let the copper react all night. The presence of sulphur compounds in the sample will be detected by the tarnishing of the copper powder. Then, concentrate the resulting solution to ca. 1 ml with a gentle stream of pure nitrogen.

4.6.2. Fractionation

An adsorption chromatography step is used to remove interfering lipids and to fractionate the extract into classes of compounds. Many variations of adsorption chromatography clean-up procedures have been published to date. Four procedures are reported here in order of increasing complexity.

Preparation of the columns: Glass burettes (1 cm diameter) with Teflon stopcocks make convenient adsorption columns. The column is plugged with pre-cleaned cotton or glass wool. Prepare separate columns for each sample and blank determination. The column is partially filled with hexane. The appropriate amount of sorbent is mixed with hexane in a small beaker to form a slurry. A glass funnel and a glass rod are used to pour the adsorbent into the column. Several rinses with hexane are necessary to fill the column to the desired height. Tap with a pencil or a hard silicone tube against the column in order to settle the adsorbent into an even bed. Flush the material adhering to the wall of the column down to the bed with solvent. Prepare each column freshly immediately before use. Never let the column get dry.

4.6.2.1. Florisil

A Florisil column is used for this fractionation, which is prepared in the following way. The Florisil should be pre-extracted in the Soxhlet apparatus to remove any contaminants, using methanol or dichloromethane for 8 hours, followed by hexane for another 8 hours. It is then dried in an oven. Activation is achieved by heating the dried Florisil at 130°C for 12 hours. It is then partially deactivated with 0.5% water by weight and stored in a tightly sealed glass jar with ground glass stopper. The water should be well mixed into the Florisil and the mixture should be allowed to equilibrate for one day before use. The activation/deactivation procedure should be carried out one day before use. A 1 cm burette with Teflon stopcock is plugged with pre-cleaned glass wool. A column with a sintered glass disk could also be used. 17 grams of Florisil are weighed out in a beaker and covered with hexane. A slurry is made by agitation and poured into the glass column. The Florisil is allowed to settle into an even bed and any Florisil adhering to the column is rinsed down with hexane. The solvent is drained to just above the Florisil bed. It should be rinsed with a further 5 ml of hexane; one gram of anhydrous sodium sulphate is added to the top of the column in order to protect the surface of the Florisil from any disturbance. The column should never run dry. Individual columns should be prepared immediately before use and a new column of Florisil used for each sample.

The extract, reduced to 1 ml, is put onto the Florisil column. It is carefully eluted with 65 ml of hexane and the first fraction collected. Then the column is eluted with 45 ml of a mixture containing 70 % of hexane and 30 % of dichloromethane and the second fraction collected. The third fraction will be eluted with 60 ml of pure dichloromethane.

Fraction one will contain the PCBs, pp' and op DDE and some other pesticides such as HCB, aldrin, heptachlor, DDMU.

Fraction two will contain the DDTs, DDDs, most of the toxaphene, and some pesticides such as the HCH isomers and chlordane components.

Fraction three will contain mainly dieldrin, endrin, heptachlor epoxide and endosulfan components. Typical chromatograms obtained are shown below.

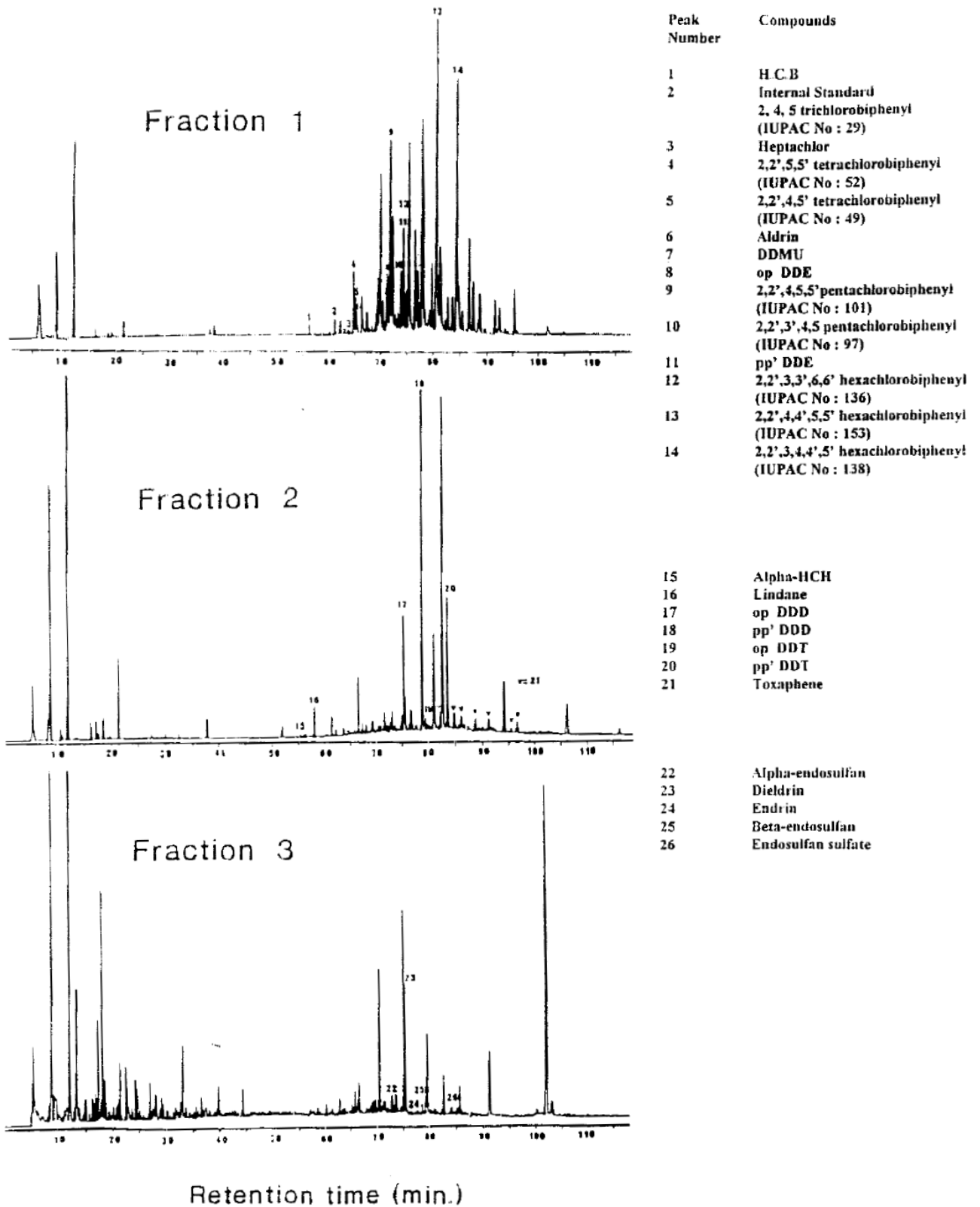

Figure 2: GC-ECD organohalogen analyses

4.6.2.2. Gel permeation chromatography

Low pressure GPC can be used as an alternative clean-up technique to remove high molecular weight co-extractable lipidic material from polycyclic aromatic compounds and halogenated aromatics. Concurrently, elemental sulphur could be also removed from the whole organic extract.

The main feature of the semi-preparative-GPC as a clean-up technique relies on the compatibility of this analytical procedure with labile components of the extract (i.e. DDTs, chlorinated cyclohexadiene derivatives), which are not stable in other types of extract clean-up procedures. Further, GPC as a clean-up technique has already been automated, enabling a high sample throughput, taking into account the short analysis time involved.

The GPC retention mechanism may involve adsorption, partition and size exclusion mechanisms. The predominance of one mechanism over the others is largely determined by the choice of the mobile phase and the pore size of the packing. In the case of GPC packings with large pore size (1000-2000 daltons) size exclusion and adsorption mechanisms prevail (Bio-Beads SX-3 using cyclohexane, dichloromethane-hexane, dichloromethane-cyclohexane, toluene-ethylacetate and ethylacetate-cyclohexane) (Ericksson *et al.*, 1986). On the other hand, when smaller pore sizes (400 daltons) are used in combination with highly polar solvents, (THF, DMF) size exclusion predominates (Lee *et al.*, 1981). While using the first approach, a chemical class fractionation could be obtained, however, if smaller pore sizes are used it should be combined with another fractionation technique (i.e. adsorption chromatography) to achieve this selectivity. It has yet to be demonstrated that using GPC as a single clean-up step produces a completely clean extract for GC-ECD determination. Nevertheless, taking into account the increasing availability of high-resolution low molecular weight exclusion packings, they could definitively integrate fractionation and clean-up in a single step.

Low resolution packing (Sephadex LH and Bio-Beads SX, 200-400 mesh size) are the most widely used because they are inexpensive and afford relatively high sample loading (500 mg in 10 mm i.d. columns). The implementation of low resolution GPC requires a solvent delivery system and a UV detector and may be useful. For method development, it is advisable to inject a broad range of standard compounds covering the whole range of molecular weights of the analytes to be determined in order to determine the cut-off points to fractionate real samples. Reported recoveries of PCBs and PAHs range from 60 to 80 % for the concentration level (ng) injected. (Fernandez and Bayona, 1992).

4.6.2.3. Alumina and HPLC (silica column)

The first step in this clean-up procedure is an adsorption step using an alumina column to remove most of the lipid material. Prepare an alumina column (4 x 0.5 cm i.d., made from a Pasteur pipette). Apply the concentrated extract to the top of the column and elute with 10 ml hexane. Concentrate the eluate to about 200 µl. It is followed by a second step to more completely remove interfering compounds and at the same time to separate the compounds of interest into different fractions, containing aliphatics, PCBs, PAHs, pesticides and toxaphene. Between 20 and 200 µl of the extract (after alumina clean-up) are eluted on a stainless steel column (200 x 4 mm i.d.), packed with Nucleosil 100-5 with n-pentane, 20 % dichloromethane in n-pentane and finally dichloromethane. The eluate is collected in fractions containing 1) n-hydrocarbons, 2) PCBs, 3) PAHs and toxaphene, 4) pesticides and toxaphene and 5) acids, etc. (polar compounds). The size of the fractions has to be determined with standard solutions containing the compounds of interest, collecting the eluate in 0.5 ml fractions. Each fraction is then analysed by GC-ECD. Full details have been given in the literature (Petrick *et al.*, 1988 and IOC, 1993).

4.6.2.4. High pressure chromatography

High pressure liquid chromatography (HPLC) columns packed with microparticles are available and have the advantages of high reproducibility, low consumption of solvents, high efficiency and high sample loading capacity.

This method can be used to separate fractions containing aliphatic hydrocarbons, PCBs and aromatic hydrocarbons from interfering compounds. These fractions can then be analysed separately for their constituents by GC-FID and/or GC-ECD.

HPLC methods have been developed using synthetic solutions of n-alkanes, PAHs, pesticides, PCBs and toxaphene and have been applied to samples in which interfering substances were present in such high concentrations as to render the analysis of HC and PCBs extremely difficult without this clean-up procedure (e.g. sediments and biological tissues with OCs in the ng/g range). The samples are eluted with n-hexane, subjected to clean-up over alumina, concentrated down to 20-200 µl and treated by HPLC. With the use of n-hexane, n-pentane and 10 %, 20 % and 50 % dichloromethane in n-hexane, respectively, the following five fractions are obtained : 1) n-hydrocarbons and alkenes, 2) PCBs and alkylbenzenes, 3) PAHs and toxaphene, 4) pesticides, 5) acids, etc.(polar compounds). (Petrick *et al.* 1988).

5. BIOTA

5.1. Sampling

Organisms accumulate many contaminants from their environment (i.e., from sea water, suspended particulate matter, sediment and food). Field and laboratory studies have shown that contaminant concentrations in some marine plants and animals reflect concentrations in their environment. Scientists use this process (termed bio-accumulation) to assess marine contamination resulting from human activity (e.g., pipeline discharges, dumping from ships).

There are problems with using biota as bio-accumulators (bio-indicators). For example, tissues from individuals of a species exposed to the same contaminant concentration may contain different levels of contamination after the same exposure time. These deviations reflect individual differences in factors such as age, sex, size, and physiological and nutritional states. Also, various species show different contaminant concentrations following identical exposure; differences in elimination rates may partially account for this. These factors must be considered when planning a monitoring programme in order to control their effects on the precision of the analysis (by reducing the variances). Variance reduction is necessary in order to detect smaller differences in mean contaminant concentrations observed in monitoring programmes.

For proper sampling and sample preparation, refer to Reference Method No 6 “Guidelines for monitoring chemical contaminants in the sea using marine organisms” and Reference Method No 12 Rev.2 “Sampling of selected marine organisms and sample preparation for the analysis of chlorinated hydrocarbons”.

5.2. Cleaning of extraction thimbles

As for extraction of sediment samples, thimbles should be extracted first with the same solvent used for the extraction of the sample. As the extraction of biota sample is achieved with hexane, a pre-extraction of these thimbles is made with 250 ml of hexane for 8 hours in the Soxhlet apparatus, cycling the solvent through at a rate of 4 to 5 cycles per hour. Add into the solvent a few carborundum boiling chips to get a regular ebullition.

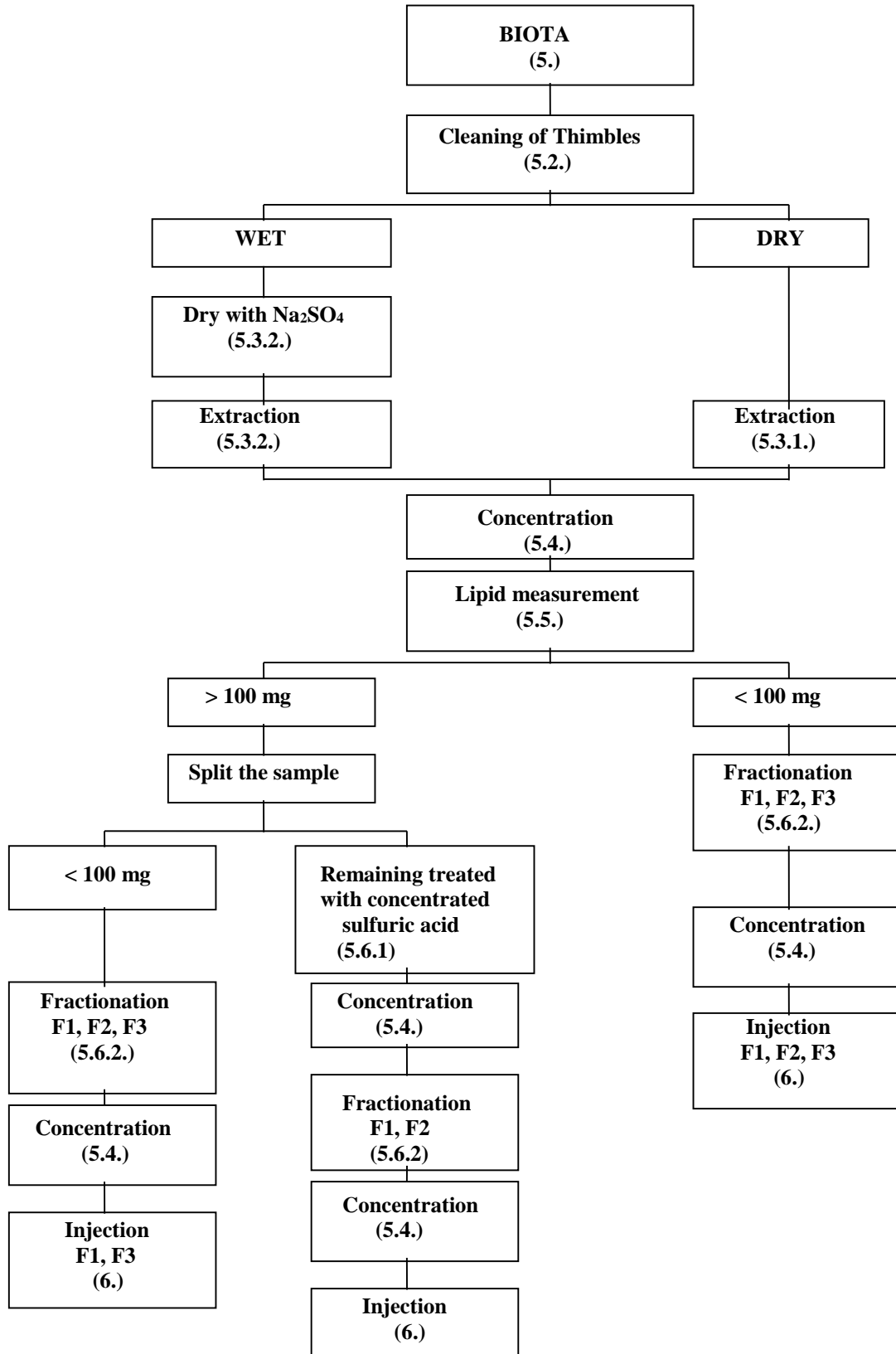

Figure 3: Diagram of the extraction procedure for biota samples.

5.3. Extraction of tissues

5.3.1. Extraction procedure for freeze-dried samples.

Take a 50 to 100 g fresh weight sub-sample from the sample. Weigh this sub-sample and freeze-dry it. When the sub-sample appears to be dry, re-weigh it and freeze-dry it for a further 24 hours and then re-weigh it. If the difference between the two dry weights is greater than 5%, continue the freeze-drying process. Special care must be taken to ensure that the freeze-drier is clean and does not contaminate the samples. The freeze drying procedure should be tested by drying 100 g Na₂SO₄ as a blank and extracting this as a sample. Pulverise the freeze-dried sub-sample carefully using a cleaned pestle and mortar. Accurately weigh about 5 to 10 g of this pulverised material, note the exact weight to be extracted, and place it into a pre-cleaned extraction thimble in a Soxhlet apparatus. The size of the sub-sample should be adjusted so that about 100 mg of extractable organic matter ("lipid") will be obtained. Smaller sub-samples should be used if residue concentrations are expected to be high. Add a known amount of internal standard to the sub-sample in the thimble before Soxhlet extraction. It is important to spike the sample at levels that are near to that of the analyte concentrations in the samples. If, in the end, the analyte and the internal standard concentrations do not fall within the established calibration range of the GC-ECD, the analysis must be repeated. Consequently, it may be advisable to perform range-finding analysis for samples of unknown character beforehand. Candidate internal standards are the same as for sediment samples (see 5.3.). Add about 200 ml of hexane or petroleum ether to the extraction flask with a few carborundum boiling chips, and extract the sample for 8 hours cycling the solvent through at a rate of 4 to 5 cycles per hour. Extract an empty thimble as a procedural blank, making sure to spike it with internal standards in the same fashion as the sample. If unacceptable procedural blanks are found, the source of contamination must be identified and eliminated rather than subtracting high blank values from the analytical results.

5.3.2. Extraction procedure without freeze-drying

Select a 25 to 100 g fresh weight sub-sample and place in a blender. Add anhydrous sodium sulphate to the sample, manually homogenise and determine whether the sample is adequately dried. If not, more sodium sulphate should be added until a dry mixture is obtained. Normally, 3 times by the sample weight used should be enough. Once this has been achieved, blend the mixture at high speed for 1 or 2 minutes until the mixture is well homogenised and the sample appears to be dry. Transfer the mixture to a pre-cleaned extraction thimble, add internal standards as described above and extract the dehydrated tissue with about 200 ml hexane or petroleum ether for 8 hours in a Soxhlet apparatus, cycling 4 to 5 times per hour. Extract the same amount of sodium sulphate as the procedural blank, making sure to add internal standards in the same fashion as the sample.

5.4. Concentration of the extract

Refer to section (4.4.)

5.5. Extractable Organic Matter (EOM)

Refer to section (4.5.)

5.6. Clean-up procedure and fractionation

5.6.1. Removal of lipids by concentrated sulphuric acid

If the lipid content of the extracts is higher than 100-150 mg, a preliminary step for the removal of the lipids is necessary before further sample purification. This can be carried out by using concentrated sulphuric acid. Treatment with sulphuric acid is used when chlorinated hydrocarbons are to be determined. However, sulphuric acid will destroy dieldrin and endrin so that an aliquot of the untreated extract must be set aside for the determination of these compounds.

CAUTION: During all this procedure it is very important to wear safety glasses.

Take an aliquot of the concentrated extract, containing about 200 mg of “lipids”, transfer into a separatory funnel and add to this extract enough hexane in order to dilute the sample (40 to 50 ml should be enough), this will allow recovery of the hexane after acid treatment, because if the sample is too concentrated, the destroyed “lipids” will become almost solid and it will be difficult then to recover the hexane from this solid mass. Add 5 ml concentrated sulphuric acid to the extract and tightly fit the glass stopper and shake vigorously. Invert the funnel and carefully vent the vapours out through the stopcock. Repeat this procedure for several minutes. Place the separatory funnel in a rack and allow the phases to separate. Four or five samples and a spiked blank are convenient to process at one time. The extract should be colourless. Recover the hexane phase into a glass beaker. Dry with sodium sulphate and transfer the hexane into a Kuderna-Danish concentrator. Reduce the volume of the extract by evaporating the solvent with a gentle stream of pure nitrogen to about 1 ml.

5.6.2. Fractionation

Refer to section (4.6.2.)

6. CAPILLARY GAS CHROMATOGRAPHIC DETERMINATIONS

6.1. Gas chromatographic conditions

- Gas chromatograph with a split/splitless injection system, separate regulation system for inlet and column pressures and temperatures; multi-ramp temperature programming facilities (preferably microprocessor controlled), electron capture detector interfaced with the column with electronic control unit and pulsed mode facilities. An integrator with a short response time (0.25 s) is essential.
- Narrow-bore (0.22 mm internal diameter), 25 m long, fused silica open tubular column, coated with SE-54 (0.17 µm film thickness, preferably chemically bonded) with sufficient resolution to separate the relevant peaks in the standards provided for PCB analysis.
- Carrier gas should be high purity H₂. If this is not available or if the GC is not equipped with a special security system for hydrogen leak, He may be used. Gas purification traps should be used with molecular sieves to remove oxygen, moisture and other interfering substances.
- High purity nitrogen gas (99.995 %) as ECD make-up gas can be used (Argon/methane high purity gas is another option).

Conditions:

- H₂ or He carrier gas at inlet pressure of 0.5 to 1 Kg/cm² to achieve a flow rate of 1 to 2 ml/min.
- Make-up gas N₂ or Ar/CH₄ at the flow rate recommended by the manufacturer (between 30 and 60 ml/min.).
- ECD temperature: 300°C

6.2. Column preparation

Fused silica columns are the columns of choice for their inertness and durability (they are extremely flexible). They are made of material that is stable up to 360 °C. The 5 % phenyl methyl silicone gum (SE-54) liquid phase, is present as a thin, (0.17 µm), uniform film which can tolerate temperatures up to 300 °C. SE-54 is relatively resistant to the detrimental effects of solvents, oxygen and water, at least at low temperatures. These columns are even more resistant and durable if the liquid phase is chemically bonded to the support by the manufacturer.

For GC/MS work, it is advised to restrict the film thickness to 0.17 µm because with thicker films some of the phase could be released, resulting in an increase of the noise signal in the GC/MS.

The flexible fused silica columns can be conveniently connected directly to the inlet and outlet systems without the transfer lines used in conventional glass capillary chromatography which often lead to increased dead volume. Low bleed graphite or vespel ferrules provide a good seal.

The presence of extraneous peaks and elevated baseline drift will result in poor detector performance. This can be caused by components which elute from the column, such as residual solvents and low molecular weight liquid phase fractions on new columns and build-up of later eluting compounds on old columns. Conditioning is a necessary step to remove these contaminants. New columns are connected to the inlet (while left unconnected to the detector). Columns are flushed with carrier gas at low temperature for 15 min. to remove the oxygen, then heated at 70-100 °C for 30 min. and finally at 170 °C overnight. The column can be then connected to the detector. Old columns can be heated directly to elevated temperatures overnight. The final temperature is selected as a compromise between time required to develop a stable baseline and expected column life. Thus, it may be necessary for older columns to be heated to the maximum temperature of the liquid phase resulting in shorter column life. The temperature of the ECD, when connected to the column, should always be at least 50 °C higher than the column, in order to avoid condensation of the material onto the detector foil. It is essential that carrier gas flows through the column at all times when at elevated temperatures. Even short exposure of the column to higher temperature without sufficient flow will ruin the column.

CAUTION: if H₂ is used as a carrier gas, position the column end outside of the oven to avoid explosion risk.

6.3. Column test

When the column has been connected to the detector, the carrier gas flow is set to 30 ml per minute for a column with 4 mm internal diameter. The column performance is then measured according to the criteria of the “number of theoretical plates” for a specific compound and can be achieved according to the following procedure.

- Set injector and detector temperatures at 200 and 300°C respectively and the column oven temperature at 180 °C.
- Inject pp’ DDT standard and measure the retention time (Tr). Adjust the column temperature to get a pp’ DDT retention time relative to Aldrin of 3.03.
- Measure the width of the pp’ DDT peak at its half height ($b_{1/2}$), in minutes and the retention time (Tr) also in minutes.
- Calculate the number of theoretical plates using the formula:

$$N = 5.54 \left(\frac{Tr}{b_{1/2}} \right)^2$$

- A parameter which is independent of the column length is the height equivalent to a theoretical plate (HETP):

$$HEPT = \frac{L}{N}$$

Where L is the column length. Adjust the flow rate of the carrier gas to obtain optimum performance. The HETP should be as low as possible (i.e. the number of theoretical plates should be as great as possible).

The column remains in optimum condition as long as the liquid phase exists as a thin, uniform film. The quality of the film at the inlet side may be degraded as a result of repeated splitless

injections. Decreased column quality may be remedied by the removal of the end of the column (10 to 20 cm) at the inlet side. Chemically bonded liquid phases require less maintenance.

6.4. Electron capture detector

High-energy electrons, emitted by a radioactive source within the detector (e.g. a ^{63}Ni foil), are subject to repeated collisions with carrier gas molecules, producing secondary electrons. These electrons, upon returning to their normal state, can be captured by sample molecules, eluting from a GC column. The resulting reduction in cell current is the operating principle of an electron capture detector. The detector current produced is actually a non-linear function of the concentration of electron-capturing material. However, the useful linear range of an ECD may be greatly improved if the instrument is operated at a constant current, but in a pulsed mode, i.e. with short voltage pulses being applied to the cell electrodes. The current in the cell is kept constant by varying the frequency of the pulses.

Contamination of the detector (and thus lower sensitivity) may result from high-boiling organic compounds eluting from the column. Periodic heating to 350°C may overcome this problem. The ^{63}Ni ECD can be used at 320°C under normal operational conditions, in order to limit such contamination.

The optimum flow for an ECD (30 to 60 ml/min.) is much higher than carrier gas flow through the column of one or two ml/min. Thus an additional detector purge flow is necessary (N_2 or Ar/CH_4). Once leaving the outlet of the column, the compounds have to be taken up into an increased gas flow in order to avoid extra-volume band broadening within the detector. Thus, the detector purge flow also serves as the sweep gas.

6.5. Quantification

The most widely used information for identification of a peak is its retention time, or its relative retention time (i.e., the adjusted retention time relative to that of a selected reference compound). Retention behaviour is temperature dependent and comparison of retention times obtained at two or more temperatures may aid in determining a peak's identity. However, retention times are not specific and despite the high resolution offered by capillary columns, two compounds of interest in the same sample may have identical retention times.

One way of using retention indexes could be to inject di-n-alkyl-phthalates such as a mixture containing di-n-methyl-phthalate, di-n-ethyl-phthalate, di-n-propyl-phthalate, di-n-butyl-phthalate, di-n-hexyl-phthalate and di-n-heptyl-phthalate, which will cover the elution range from 70°C to 260°C. An arbitrary index of 100 is given to the di-n-methyl phthalate, 200 to the di-n-ethyl phthalate, and so on up to 700 to the di-n-heptyl phthalate; it is possible to identify all chlorinated pesticides by a proper retention index. This will be used also for unknown compounds which can be found easily on the GC/MS using the same index and so, identified. (Villeneuve J.P. 1986).

PCBs represent a complex mixture of compounds that cannot all be resolved on a packed column. Also there is no simple standard available for their quantification. Each peak in a sample chromatogram might correspond to a mixture of more than one individual compound. These difficulties have led to the recommendation of various quantification procedures. The usual method to quantify PCBs is to compare packed-column chromatograms of commercially available industrial formulations (Aroclors, Clophens, Phenoclor) with the sample chromatogram. Most commonly, it is possible to match one single formulation, such as Aroclor 1254 or Aroclor 1260 with the sample chromatogram. An industrial formulation (or mixture of formulations) should be chosen to be as close a match as possible and in the case of sample extracts from sediment or organisms, Aroclor 1254 and Aroclor 1260 are most frequently chosen.

For the second fraction obtained on Florisil separation, it is possible to quantify DDTs after comparison with the retention times of peaks in the sample chromatogram to those in the corresponding standard, the peak heights (or peak areas) are measured and related to the peak height (or peak area) in the standard according to the formula:

$$[\text{Concentration}] = \frac{h \times C \times V \times 1000}{h' \times V(\text{inj}) \times M \times R} \text{ ng/g (or pg/g)}$$

Where:

- V = total extract volume (ml)
- M = weight of sample extracted (g)
- H = peak height of the compound in the sample
- h' = peak height of the compound in the standard
- C = quantity of standard injected (ng or pg)
- V (inj) = volume of sample injected (µl)
- R = Recovery of the sample

7. COMPUTERIZED GAS CHROMATOGRAPHY/MASS SPECTROMETRY (GC/MS)

7.1. Operating conditions

The chemical ionisation source of a mass spectrometer can be used to produce negative ions by electron capture reactions (CI-NI-MS) using a non-reactive enhancement gas such as methane or argon. CI-NI has the advantage of being highly selective, permitting the detection of specific compounds in complex matrices. Under CI-NI conditions, methane (99.99 %) is used as the reagent gas. Samples are introduced through a SE-54, 30 m x 0.25 mm i.d., fused silica column. The film thickness used is 0.17 µm in order to minimise the bleeding of the phase into the system. Helium is used as carrier gas with an inlet pressure of 13 psi, which gives a carrier flow of 1.5 ml/min. or a gas velocity of 44 cm/sec.

The temperature of the injection port is held at 250°C.

The temperature of the source is set at 240°C, the quadrupole at 100°C and the interface at 285°C.

Injections of 1-3 µl are made in the splitless mode.

The temperature programme of the oven starts at 70°C, for 2 minutes, then it is increased at 3°C/min. to 260°C and kept under isothermal conditions for 40 minutes.

File : C:\HPCHEM\1\DATA\AR1254.D
Operator : jpv
Acquired : 12 Jul 95 8:02 am using AcqMethod OC
Instrument : 5989B
Sample Name: standard ar1254
Misc Info :
Vial Number: 1

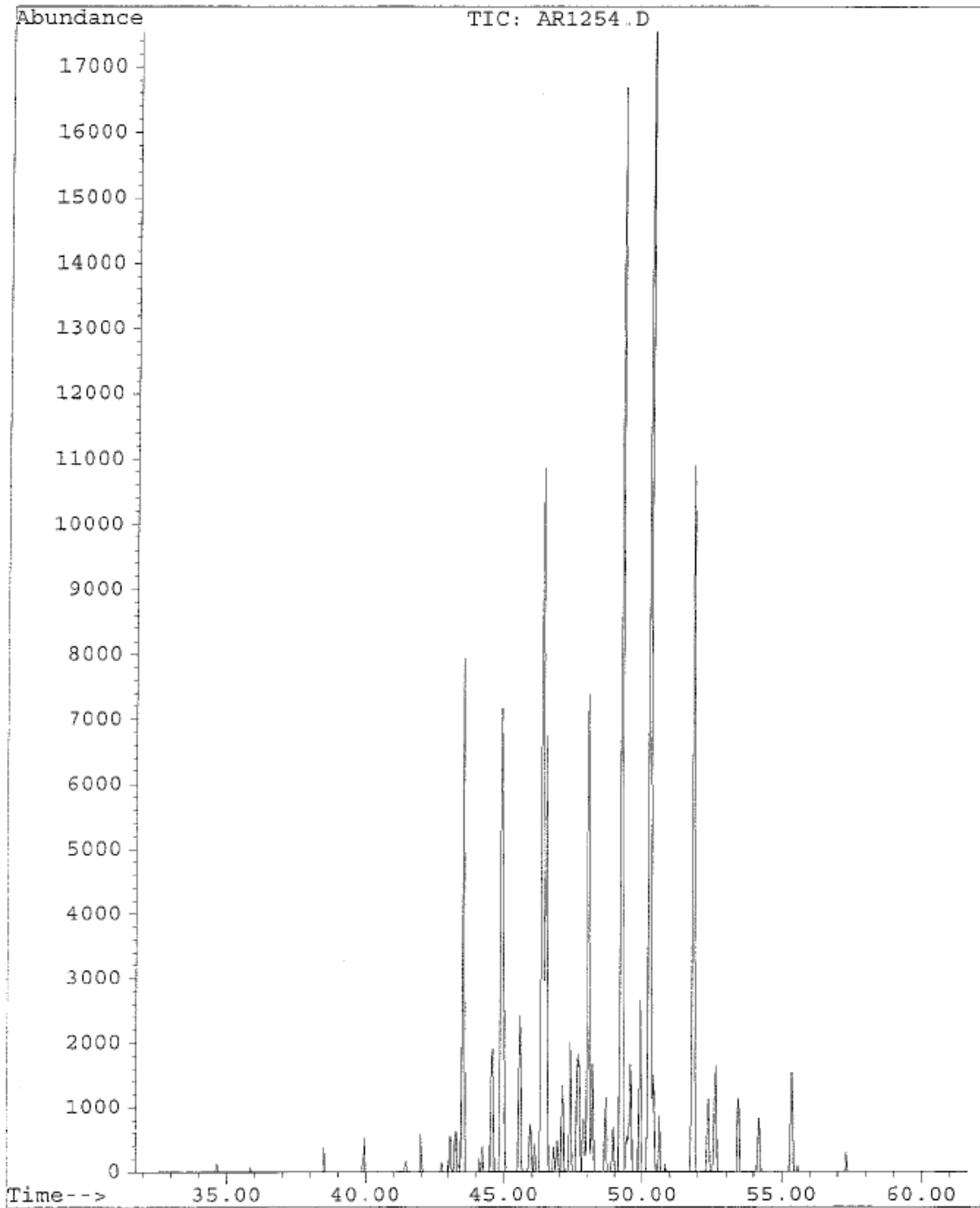

Figure 4: TIC of Aroclor 1254

File : C:\HPCHEM\1\DATA\AR1254.D
Operator : jpv
Acquired : 12 Jul 95 8:02 am using AcqMethod OC
Instrument : 5989B
Sample Name: standard ar1254
Misc Info :
Vial Number: 1

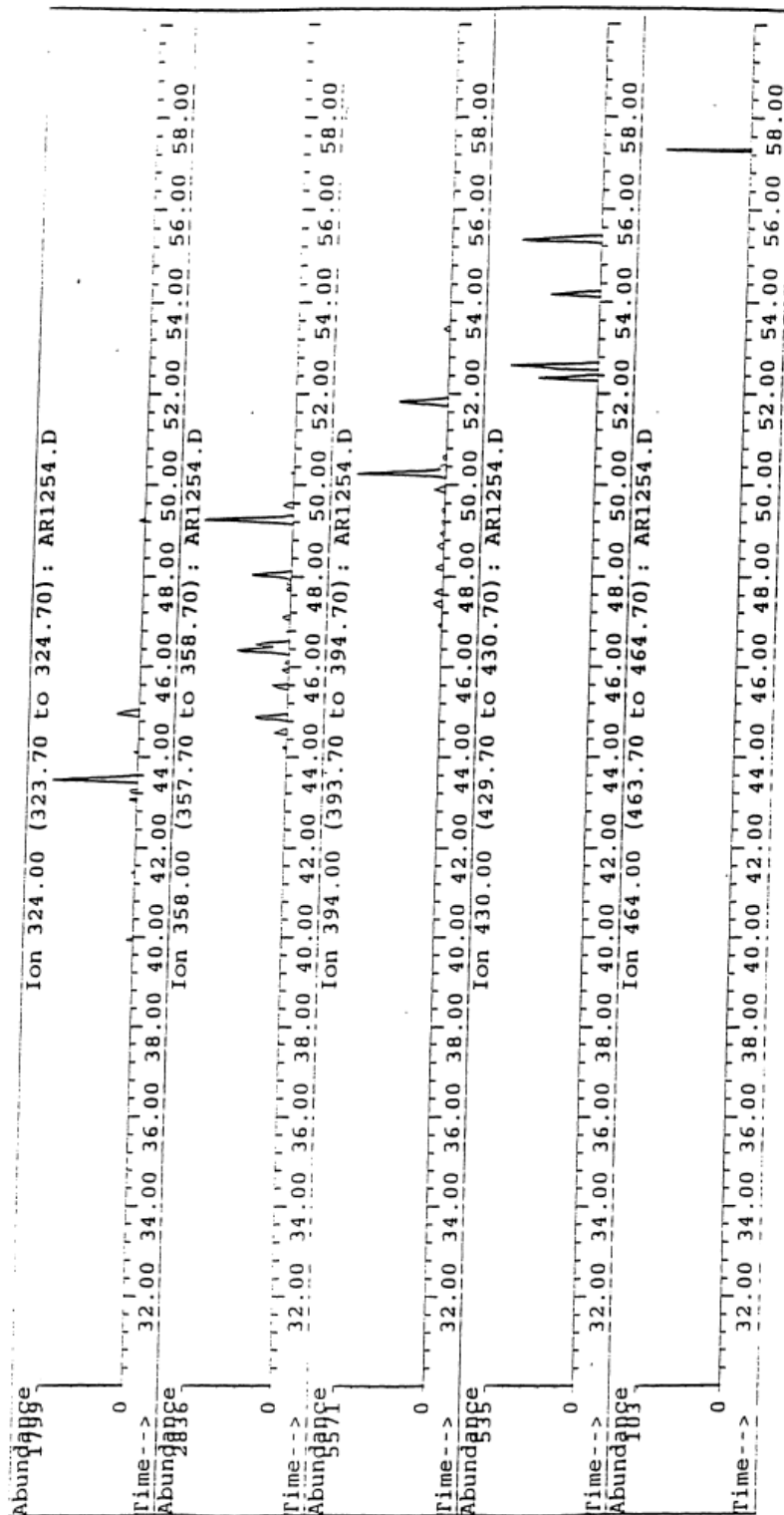

Figure 5: RIC of Aroclor 1254 main compounds

File : C:\HPCHEM\1\DATA\AR1260.D
Operator : jpv
Acquired : 12 Jul 95 9:42 am using AcqMethod OC
Instrument : 5989B
Sample Name: standard ar1260
Misc Info :
Vial Number: 1

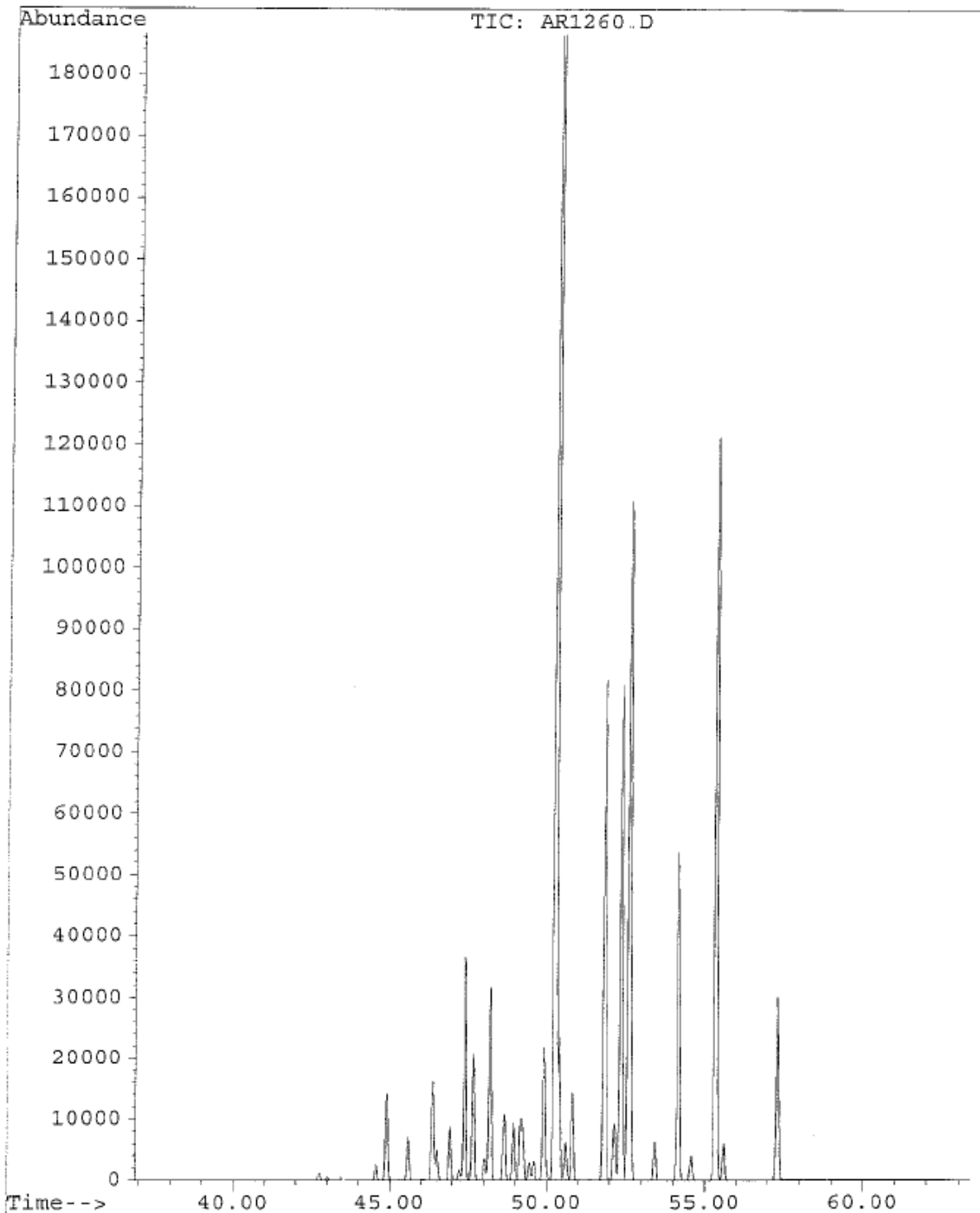

Figure 6: TIC of Aroclor 1260

File : C:\HPCHEM\1\DATA\AR1260.D
 Operator : jpv
 Acquired : 12 Jul 95 9:42 am using AcqMethod OC
 Instrument : 5989B
 Sample Name: standard ar1260
 Misc Info :
 Vial Number: 1

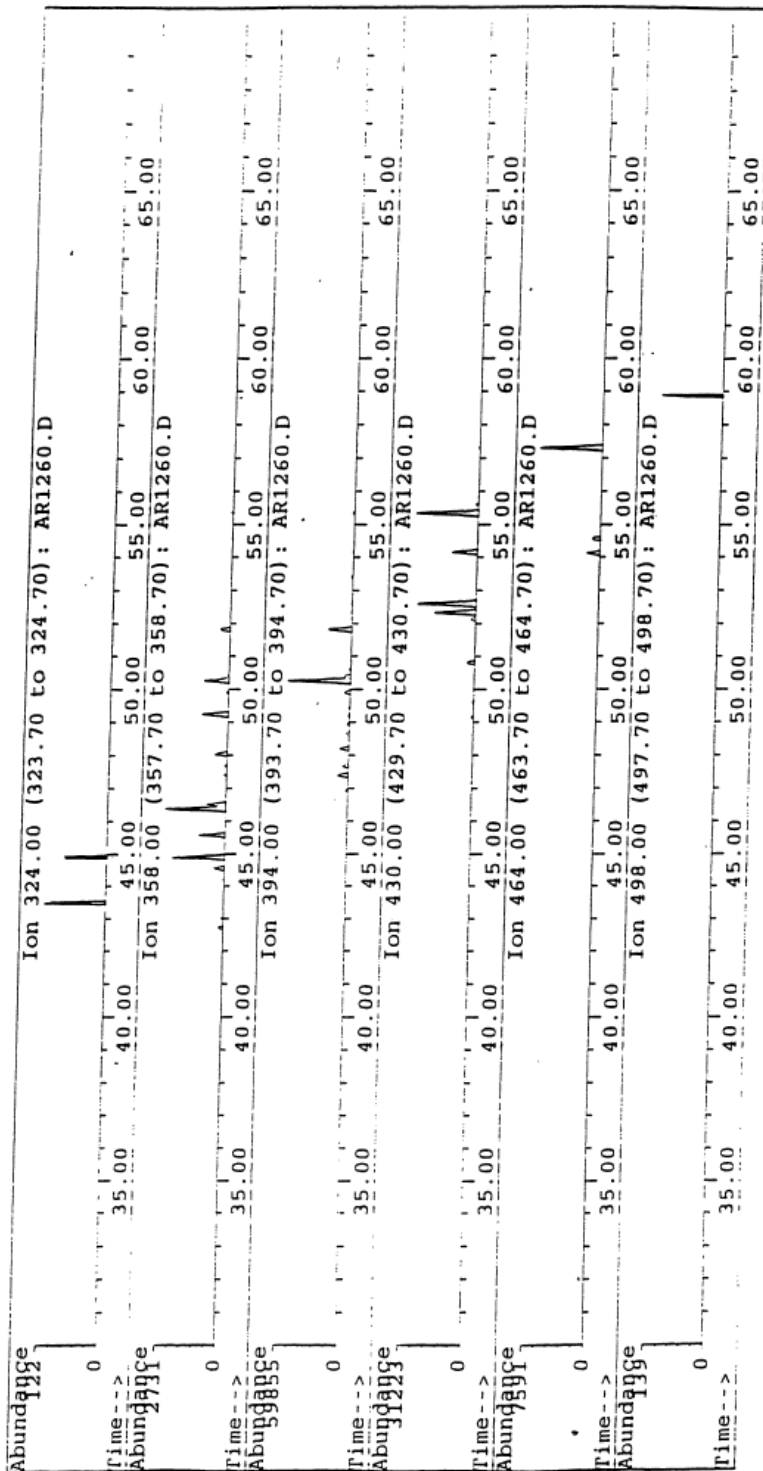

Figure 7: RIC of Aroclor 1260 main compounds

7.2. Example of a selected ion monitoring programme useful for quantitative analysis of chlorinated compounds.

Compounds	Fraction N° on Florisil	Retention Time (min.)	Target Ion (daltons)
HCB	1	37-38	284
Heptachlor	1	44-45	266
Aldrin	1	46-48	237
op DDE	1	51-53	246
Transnonachlor	1	52-54	444
pp' DDE	1	53-55	281
PCBs			
3 Cl	1		258
4 Cl	1		292
5 Cl	1	40-55	324
6 Cl	1	40-55	358
7 Cl	1	45-55	394
8 Cl	1	45-60	430
9 Cl	1	50-60	464
10 Cl	1	58-60	498
α HCH	2	37-39	255
β HCH	2	39-41	255
γ HCH (Lindane)	2	39-41	255
δ HCH	2	41-43	255
γ Chlordane	2	51-53	410
α Chlordane	2	52-54	266
op DDD	2	54-56	248
pp' DDD	2	56-58	248
op DDT	2	56-58	246
pp' DDT	2	58-60	283
Heptachlor epoxide	3	49-51	318
α Endosulfan	3	52-54	406
Dieldrin	3	53-55	346
Endrin	3	55-57	346
β Endosulfan	3	55-57	406
Endosulfan sulfate	3	58-60	386

8. NOTES ON WATER ANALYSIS

The levels of lipophilic compounds in tissues of aquatic organisms and organic fractions of sediments are determined to a large extent by the levels of these compounds in the surrounding water (marine mammals are an obvious exception). Data for CBs and hydrocarbons in sea water is therefore extremely useful for an understanding of the levels in organisms. However, the levels in sea water are extremely low and consequently, their determination needs considerable experience. Large volumes of water are required and extreme care has to be taken in order to avoid contamination during sampling, extraction and clean-up of the samples. Details are described in Manual and guide No 27 of IOC, 1993 and Villeneuve J.P. (1986).

9. ALTERNATIVE PROCEDURES

9.1. Combining sample preparation and extraction for chlorinated and petroleum hydrocarbons in sediment samples.

In the event that analyses for petroleum hydrocarbons and chlorinated compounds (and/or sterols) are of interest, the following extraction procedure can be used. To the freeze-dried sample introduce internal standards for each compound class. The following are suggested: 1) aliphatic hydrocarbons: - n-C₁₄ d₃₀, n-C₁₉ d₄₀, n-C₃₂ d₆₆, 2) polycyclic aromatic hydrocarbons: Naphthalene d₈,

Hexamethylbenzene, Cadalene (deuterated PAHs are also useful), 3) organochlorine compounds: PCB congeners 29, 30, 121 or 198, ϵ HCH and Endosulfan Id₄, 4) sterols: 5 α (H)-androstan-3 β -ol. These standards are used for quantifying the recovery of the total procedure. Samples are Soxhlet extracted for 8 hours with 250 ml of a mixture hexane / dichloromethane (50:50), cycling the solvent through at a rate of 4 to 5 cycles per hour. The solvent extract is concentrated by rotary evaporation down to 15 ml and transferred to a Kuderna-Danish tube. It is then further concentrated down to 5-6 ml under nitrogen gas. Following removal of sulphur and water, the extract is separated into aliquots: 1/3 for petroleum hydrocarbons and sterols and 2/3 for chlorinated hydrocarbons.

Note: Mercury method should be used only if chlorinated pesticides and PCBs are analysed. If the combined method is used for petroleum and chlorinated hydrocarbons, then the copper method should be used instead of mercury that will destroy some of the PAHs.

9.2. Supercritical fluid extraction (SFE) of marine samples

Sample preparation is probably the most time-consuming and labor-intensive analytical task performed in a laboratory. Studies shows that 60 % of the overall sample analysis time is spent in sample preparation which is the main source of error and of contamination. In addition, the amount of hazardous chemicals used for sample preparation is a continuous source of concern. Due to safe handling and disposal requirements, the reduction of their use is a priority for laboratories worldwide.

Supercritical fluids are gases (i.e. N₂O and CO₂) at room temperature and pressures above the critical point. The SFE technique allows an efficient extraction of a variety of contaminants with considerable reduction in the analysis cost, sample amount and allows the extraction of the thermal sensitive substances, reducing the amount of environmentally hazardous solvents.

A small change in the pressure of a supercritical fluid results in a big change in its density and the solvent strength of the fluid changes with changing density. As a result, one supercritical fluid easily performs the work of many solvents. If this is not enough, it is possible to add a modifier, such as methanol (a few per cent) to increase the solvating range of the fluid. Therefore, SFE should speed up the sample preparation process, minimising the wastes associated with the analysis.

Until now, the main fields of analytical applications of SFE are related to environmental studies and to the food-processing industry (Hawthorne, 1990, Bayona, 1993). A method using carbon dioxide (80°C-340 atm) for the extraction of total petroleum hydrocarbons has been approved as an EPA standard method. The extraction efficiency of modified CO₂ for the recovery of 41 organochlorine and 47 organophosphorus pesticides spiked on sand at different pressures and temperatures were higher than 80%. Furthermore, by increasing the extraction temperature up to 200°C, PCBs and PAHs can be extracted from naturally occurring samples with neat CO₂. Nam *et al.* (1991), have developed a method for rapid determination of polychlorinated organics in complex matrices. The method is based on direct coupling of supercritical fluid extraction with tandem supercritical fluid chromatography and gas chromatography. The on-line system permits simultaneous extraction and analysis with high reproducibility and accuracy.

**Selection guide for CO₂ extraction of common pollutants
 (from Hewlett-Packard)**

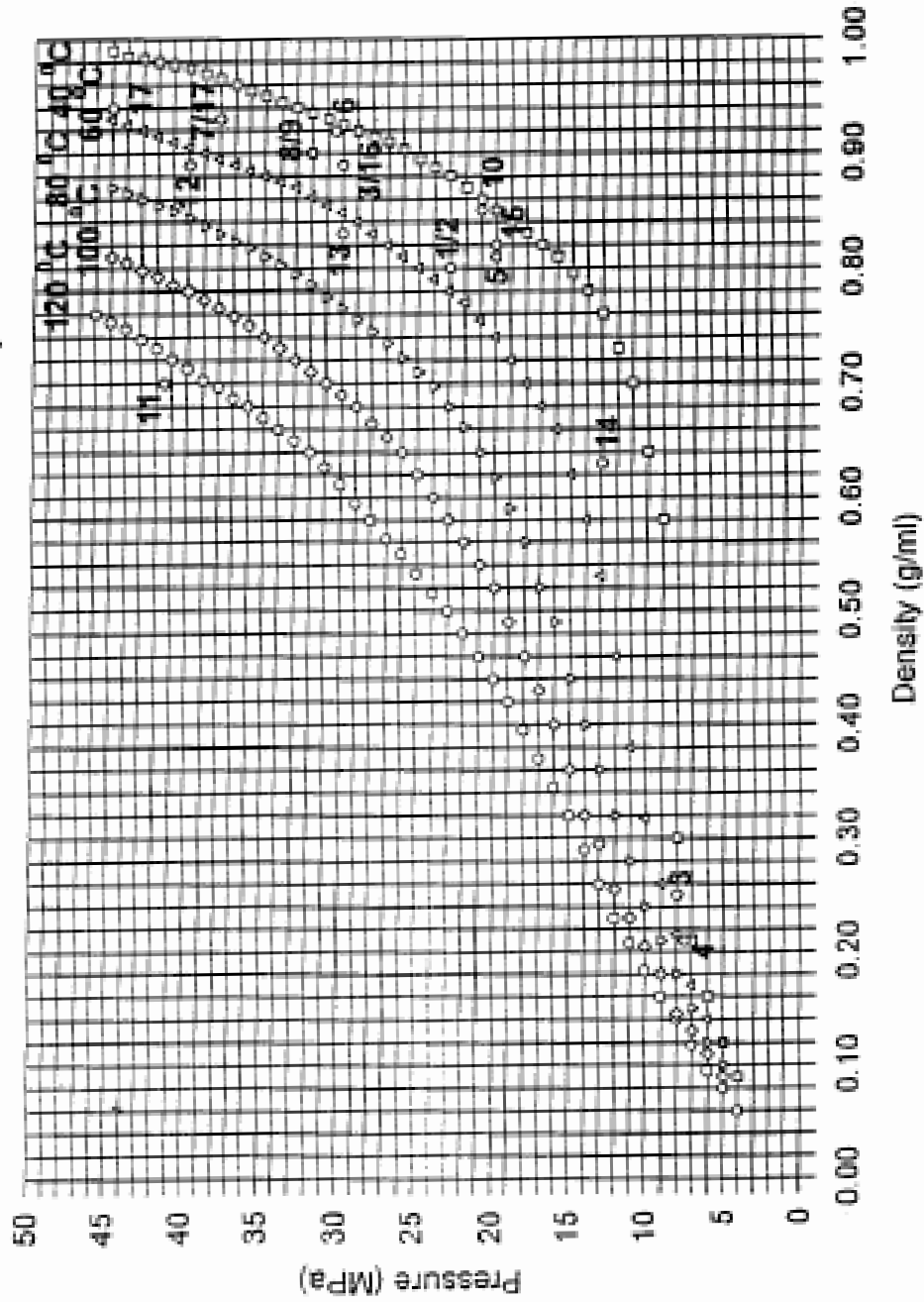

Figure 8: Guide for CO₂ extractions

9.3. Microwave assisted extraction for marine samples

9.3.1 Sediment

Another alternative method for the extraction of chlorinated hydrocarbons in sediment samples (or combined extraction for chlorinated hydrocarbons and petroleum hydrocarbons) is the use of the Microwave oven instead of the Soxhlet extractor. The main advantage of the microwave oven is the fact that, for one sample, only 40 ml of solvent mixture are used instead of 250 ml for clean-up of extraction thimbles and 250 ml for the extraction itself.

10 to 15 grams of freeze-dried sediment sample, ground and sieved at 250 µm, are put in the glass tube of the reactor. Appropriate internal standards (for OCs and/or PHs, see 10.1.) are added to the sample for recovery and samples are extracted with 40 ml of a mixture of hexane / dichloromethane (50:50).

Extraction is realised within the following cycle:

- Power of the microwaves: 1200 watts
- Temperature increase to 115 °C in 10 minutes.
- Extraction maintained at 115 °C for 30 minutes
- Cooling to ambient temperature within one hour.

The carousel containing 14 reactors, 12 samples could be extracted together with one blank and one Reference Material within 1 and half hour and with 10 times less solvent mixture than the standard Soxhlet extraction.

After cooling down to room temperature the solvent mixture is recovered in a 100 ml glass flask. The sediment is poured in a glass funnel containing a plug made of glass wool. The extracted sediment is washed with 10 - 20 ml of hexane. The extract follows then the procedure of clean-up and fractionation.

9.3.2 Biota

3 to 8 grams of freeze-dried biota sample is accurately weighted, the weight to be extracted is noted, and it is placed into the pre-cleaned glass tube of the reactor. A known amount of internal standard is added to the sub-sample in the tube before extraction. Candidate internal standards are the same than for sediment samples refers to section (5.3.1.)

Extraction is realized with 30 ml of a mixture hexane / acetone (90:10) within the following cycle:

- Power of the microwaves: 1200 watts
- Temperature increase to 115 °C in 10 minutes.
- Extraction maintained at 115 °C for 20 minutes
- Cooling to ambient temperature within one hour.

The carousel containing 14 reactors, 12 samples could be extracted with one blank and one Reference Material within 1 and half hour and with 10 times less solvent mixture than the standard Soxhlet extraction.

After cooling down to room temperature the solvent mixture is recovered in a 100 ml glass flask. The powder of biota is poured in a glass funnel containing a plug made of glass wool. The extracted biota is washed with 10 - 20 ml of hexane. The extract is then concentrated with rotary evaporator and ready for E.O.M, clean-up and fractionation procedure.

10. DATA INTERPRETATION

10.1. DDT

The residence time of total DDT in the environment is relatively short ($t_{1/2} = 3-5$ years), so, at least 75-80 % of the current total DDT should be in the form of DDE or DDD if it was introduced into the environment before the 1975 ban. Values of Henry's law constant indicate that these compounds can reach the troposphere as vapour. These vapours are little adsorbed by airborne particulate matter and represent the major component in atmospheric chlorinated hydrocarbon levels. Vapour movements of these pollutants suggest that restrictions and regulations operating in the more technically advanced countries could only be partially effective on a worldwide basis.

The presence of the *op* DDT together with anomalous *pp'* DDT values in environmental samples indicates a recent treatment with this insecticide.

10.2. PCBs congeners

Among the 209 possible PCB congeners, seven of them: 28, 52, 101, 118, 138, 153 and 180, were selected as the most relevant because of their distribution in the chromatogram and in the chlorination range.

Recently, attention has been paid to congeners having 2 para-chlorines and at least 1 meta-chlorine. These congeners are called "coplanar" PCBs. Among the 209 congeners, 20 members attain coplanarity due to non-ortho chlorine substitution in the biphenyl ring. Three of these show the same range of toxicity as the 2,3,7,8 tetrachlorodibenzo-p-dioxin and the 2,3,7,8 tetrachlorodibenzofuran, these are the IUPAC N^o: 77, 126 and 169. These compounds should be identified and quantified in the environmental samples with high priority. They can be separated using fractionation with carbon chromatography (Tanabe *et al.*, 1986).

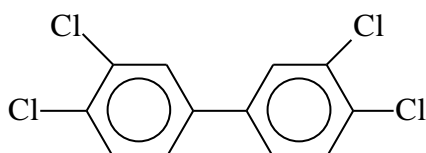

3,3',4,4' tetrachlorobiphenyl
IUPAC N^o: 77

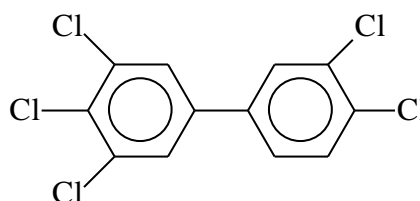

3,3',4,4',5 pentachlorobiphenyl
IUPAC N^o: 126

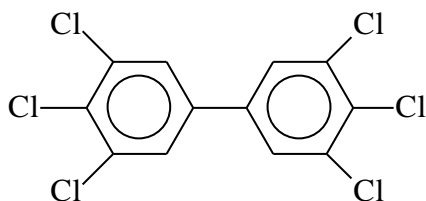

3,3',4,4',5,5' hexachlorobiphenyl
IUPAC N^o: 169

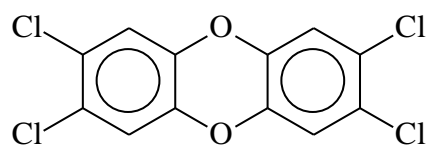

2,3,7,8 tetrachlorodibenzo-p-dioxin

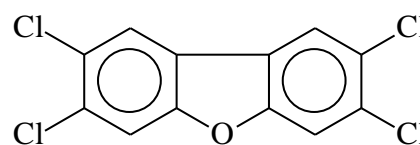

2,3,7,8 tetrachlorodibenzofuran

10.3. Typical profiles of commercial mixtures

Formulations available in different countries are slightly different in their composition (Aroclor in USA, Kanechlor in Japan, Clophen in Germany, Phenoclor in France, Fenclor in Italy or Sovol in Russia). For the same global composition, such as Aroclor 1254, KC-500 or Phenoclor DP-5, the composition of individual congeners differs by 5-10 %. If a sample is collected on the French coast (therefore, contaminated with DP-5), and is quantified with DP-5 and Aroclor 1254, the difference observed in concentration could be in the order of 5-10 %. This shows the importance of choosing one common standard for the quantification of global industrial formulations or the importance of quantifying with individual congeners.

Percent contribution of individual chlorobiphenyls to Clophen A 50 and Aroclor 1254.

PCB N°	Clophen A50	Aroclor 1254	PCB N°	Clophen A50	Aroclor 1254
17	0	0.19	115	0.28	0.3
18	0	0.41	118	10.9	6.39
28	0.05	0.25	119	0.19	0.14
31	0.05	0.22	122	0.19	0.5
33	0.11	0.14	123	0.85	0.81
40	0.28	0.2	126	0.08	0
41	0.83	0.64	128	3.04	2.07
42	0.13	0.23	129	0.83	0.23
44	2.46	2.03	130	0.83	0.63
47	0.18	0.11	131	0.06	0.16
48	0.17	0.14	132	2.57	1.98
49	1.96	1.64	134	0.52	0.49
52	5.53	5.18	135	1.61	1.62
53	0.06	0.09	136	0.91	1.12
56	0.44	0.58	137	0.25	0.25
60	0.34	0.54	138	3.61	3.2
63	0.15	0.05	141	0.98	1.04
64	0.71	0.45	146	0.8	0.83
66	0.5	0.59	149	4.5	2.21
67	0.13	0.09	151	1.22	1.17
70	3.85	3.21	153	4.17	4.26
74	1.35	0.78	156	1.43	1.62
82	1.05	0.95	157	0.31	0
83	0.53	0.45	158	0.98	0.77
84	2.08	1.95	167	0.35	0.21
85	1.85	1.66	170	0.65	0.31
87	4.22	3.78	171	0.5	0.5
90	0.85	0.93	172	0.09	0.05
91	0.92	0.83	173	0.09	0.09
92	1.53	1.58	174	0.37	0.34
95	6	6.02	175	0.11	0.05
96	0.05	0.08	176	0.43	0.32
97	2.8	2.55	177	0.21	0.21
99	4.06	3.6	178	0.19	1.35
100	0.15	0.1	179	0.2	0.21
101	7.72	7.94	180	0.53	0.38
105	1.9	3.83	183	0.21	0.17
107	0.94	0.72	187	0.3	0.32
110	6.27	5.85	190	0.05	0.08
			201	0.6	0.68

11. QUALITY ASSURANCE / QUALITY CONTROL

Guidelines on the QA/QC requirements for analysis of sediments and marine organisms are detailed in Reference Method No 57, "Contaminant monitoring programs using marine organisms: Quality assurance and good laboratory practice". Brief descriptions of issues that must be addressed in the course of understanding the procedures described here are given below.

11.1. Precision

The precision of the method should be established by replicate analysis of samples of the appropriate matrix. Estimate the precision of the entire analytical procedure by extracting five sub-samples from the same sample after homogenisation. Alternatively, perform replicate analysis of an appropriate certified reference material (RM; see below) containing the analytes of interest. The principal advantage of using a RM is that the material permits the simultaneous evaluation of accuracy while offering a well homogenised sample. Precision should be evaluated as a matter of course during the initial implementation procedure just before initiation of sample analysis.

11.2. Accuracy

The accuracy of the methods described here must be confirmed by analysis of a suitable RM (i.e. appropriate matrix, analytes) prior to initiation of sample analysis. Agreement between measured and certified concentrations for any individual analyte should be within 35 % and on average within 25%. It is advisable to introduce RMs on a regular basis (e.g. every 10-20 samples) as a method of checking the procedure. Further description of the preparation of control charts and criteria for data acceptance are discussed in Reference Method N° 57.

11.3. Blanks

Blanks represent an opportunity to evaluate and monitor the potential introduction of contaminants into samples during processing. Contributions to the analyte signal can arise from contaminants in the reagents, those arising from passive contact between the sample and the environment (e.g. the atmosphere) and those introduced during sample handling by hands, implements or glassware. It is essential to establish a consistently low (i.e. with respect to analytes) blank prior to initiating analysis or even the determination of the method detection limit. In addition, it is necessary to perform blank determinations on a regular basis (e.g. every batch of samples).

11.4. Recovery

Recovery reflects the ability of the analyst to fully recover surrogate compounds introduced to the sample matrix or blank at the beginning of the procedure. The primary criteria for selection of compounds to be used for testing recovery are that they: 1) have physical (i.e. chromatographic/partitioning) properties similar to and if necessary spanning those of the analytes of interest, 2) do not suffer from interferences during gas chromatographic analysis, 3) are baseline resolved from the analytes of interest.

Recovery should be tested on all samples and blanks as a routine matter of course. Recoveries below 70% are to be considered unacceptable. Recoveries in excess of 100 % may indicate the presence of interference.

11.5. Archiving and reporting of results

Every sample should have an associated worksheet which follows the samples and the extracts through the various stages of the procedure and upon which the analyst notes all relevant details. An example of such a worksheet is given below. Each laboratory should construct and complete such a worksheet. Relevant chromatograms should be attached to the worksheet. Analyses should be grouped

and composite or summary analysis sheets archived with each group. Final disposal of the data will depend on the reasons for which it was collected but should follow the overall plan model.

All processed samples should be archived at all steps of the procedure:

- deep frozen (in the deep-freezer as it was received).
- freeze-dried (in sealed glass container kept in a dark place).
- extracted (after injection on the GC, sample extracts should be concentrated down to 1 ml and transferred into sealed glass vials, a Pasteur pipette sealed with a butane burner is adequate and cheap).

Sample: IAEA-357 : Marine Sediment

wet wt.
----- =, % water in freeze dried sample determined by drying at 105°C :
dry wt.

.....g freeze-dried wt. extracted with hexane in Soxhlet extractor for 8 hours.

.....pg PCB N°29,pg PCB N°198,pg ε HCH and pg Endosulfan Id₄ were added as internal standard.

Theml extract was reduced by rotary evaporator to approximatelyml.

This was treated with sodium sulfate to dry the extract. Then treated with mercury to remove sulphur. This was further reduced toml for lipid determinations. Corrected dry wt. :g.

Lipid determinations:

.....ml total extract;

10 µl aliquots weighed on micro-balance:mg;mg;mg.

HEOM =mg/g dry weight.

.....mg lipid subjected to column chromatography fractionation on Florisil.

F1:ml hexane

F2:ml hexane/dichloromethane (70:30)

F3:ml dichloromethane

GC determinations:

PCB N°29 :ng recovered in F1 :% Recovery.

PCB N°198 :ng recovered in F1 :% Recovery.

ε HCH :ng recovered in F2 :% Recovery.

Endosulfan Id₄:ng recovered in F3 :% Recovery.

Attach tabulation of individual compounds quantified in sample.

Sample worksheet for analysis of chlorinated compounds in marine sediments.

12. REFERENCES

- Bayona, J.M. (1993). The role of supercritical fluid extraction in sample preparation. *Robotics Lab. Autom.* 5, 156-187.
- Eganhouse, R.P. and Kaplan, I.R. (1988). Depositional history of recent sediments from San Pedro shelf, California: Reconstruction using elemental abundance, isotopic composition and molecular markers. *Mar. Chem.*, 24 (2), 163-191.
- Eisenreich, S.J., Capel, P.D., Robbins, J.A. and Bourbonniere, R. (1989). Accumulation and diagenesis of chlorinated hydrocarbons in lacustrine sediments. *Environ. Sci. and Technol.*, 23, 1116-1126.
- Ericksson, M.D. (1986). *Analytical Chemistry of PCBs*, Butterworth, Stonehaus, 149-153.
- Fernandez, P., Porte, C., Barcelo, D., Bayona, J.M. and Albaiges, J. (1988). Selective enrichment procedures for the determination of polychlorinated biphenyls and polycyclic aromatic hydrocarbons in environmental samples by gel permeation chromatography. *J. Chromatogr.* 456, 155-164.
- Fernandez, P. and Bayona, J.M. (1992). Use of off-line gel permeation chromatography - normal phase liquid chromatography for the determination of polycyclic aromatic compounds in environmental samples and standard reference materials (air particulate matter and marine sediment). *J. Chromatogr.*, 625, 141-149.
- Hawthorne, S.B. (1990). Analytical-scale supercritical fluid extraction, *Anal. Chem.*, 62, 633A-642A.
- Hom, W., Risebrough, R.W., Soutar, A. and Young, D.R. (1974). Deposition of DDE and polychlorinated biphenyls in dated sediments of the Santa Barbara basin. *Science*, 184, 1197-1199.
- Langenfeld, J.J., Hawthorne, S.B., Miller, D.J. and Pawliszyn, J. (1993). Effects of temperature and pressure on supercritical fluid extraction efficiencies of polycyclic aromatic hydrocarbons and polychlorinated biphenyls. *Anal. Chem.* 65, 338-344.
- Lee, M.L., Novotny, M.V. and Bartle, K.D. (1981), in *Analytical Chemistry of Polycyclic Aromatic Compounds*, Academic Press, New York, 143-152.
- Lopez-Avila, V., Dohiwala, N.S. and Beckert, W.F. (1990). "Supercritical fluid extraction and its applications to environmental analysis. *J. Chromatogr. Sci.* , 28, 468-79.
- Lopez-Avila, V., Benedicto, J., Dohiwala, N.S., Young, R. and Beckert, W.F. (1992). Development of an off-line SFR-IR method for petroleum hydrocarbons in solids. *J. Chromatogr. Sci.*, 30, 335-343.

Manuals and Guides No 27. IOC (1993).

- Nam, K.S., Kapila, S., Yanders, A.F. and Puri, R.K. (1991). A multiple sample extraction and on-line system for the analysis of chlorinated compounds. *Chemosphere*, 23, 1109-1116.
- Petrick, G., Schulz, D.E. and Duinker, J.C. (1988). Clean-up of environmental samples by high-performance liquid chromatography for analysis of organochlorine compounds by gas chromatography with electron-capture detection. *J. Chromatogr.*, 435, 241-248.
- Reference Method No 6, UNEP/FAO/IOC/IAEA: Guidelines for monitoring chemical contaminants in the sea using marine organisms. UNEP, 1993.
- Reference Method No 12 Rev.2, UNEP/FAO/IAEA/IOC: Sampling of selected marine organisms and sample preparation for the analysis of chlorinated hydrocarbons. UNEP, 1991.
- Reference Method No 20, UNEP/IOC/IAEA: Determination of petroleum hydrocarbons in sediments. UNEP, 1992.
- Reference Method No 57, UNEP/IOC/IAEA/FAO: Contaminant monitoring programme using marine organisms: Quality assurance and good laboratory practice. UNEP, 1990.

Reference Method No 58: Guidelines for the use of sediments for marine pollution monitoring programmes. (in preparation).

Reference Method No 65, UNEP/IOC/IAEA: Reagent and laboratory ware clean-up procedures for low-level contaminants monitoring. (in preparation).

Tanabe, S., Kannan, N., Wakimoto, T. and Tatsukawa, R. (1986). Method for the determination of three toxic non-ortho-chlorine substituted co-planar PCBs in environmental samples at part-per-trillion levels. Intern. J. Environ. Anal. Chem. Vol. 29, 199-213.

UNEP (DEC)/MED WG.282/Inf.5/Rev1: Methods for sediment sampling and analysis (2006).

Villeneuve, J.P. (1986). Géochimie des composés organochlorés dans l'environnement marin. Thèse de Doctorat de l'Université Paris VI. 180 pages.

ANNEX

**PREPARATION OF THE SOLUTION OF INTERNAL STANDARDS:
PCB No 29, PCB No 198, ϵ HCH and Endosulfan I d4**

Stock Solution of PCB No 29:

1 ml from the original vial (250ng/ μ l) should be transferred into a 100 ml volumetric flask, and then the volume is adjusted to 100 ml with hexane. This stock solution contains:

2.5 ng/ μ l of PCB No 29

Stock Solution of Endosulfan I d4:

1 ml from the original vial (250ng/ μ l) should be transferred into a 100 ml volumetric flask, and then the volume is adjusted to 100 ml with hexane. This stock solution contains:

2.5 ng/ μ l of Endosulfan I d4

Working solution of internal standards:

0.5 ml from the stock solution of PCB No 29 (2.5 ng/ μ l) should be transferred into a 50 ml volumetric flask, then, 0.5 ml from the stock solution of Endosulfan I d4 (2.5 ng/ μ l) should be transferred into the volumetric flask, then 1 ml from the original vial (1ng/ μ l) of ϵ HCH should be transferred into that volumetric flask, then 0.5 ml from the concentrated solution (2ng/ μ l) of PCB No 198, and the volume adjusted to 50 ml with hexane. This working solution contains:

25 pg/ μ l of PCB No 29

20 pg/ μ l of PCB No 198

20 pg/ μ l of ϵ HCH

25 pg/ μ l of Endosulfan I d4

CAUTION: VIALS SHOULD BE COOLED AT 20°C PRIOR TO OPENING

Preparation of the Aroclor 1254 solution

Preparation of the stock solution:

1 ml from the original vial should be transferred into a 100 ml volumetric flask, then, the volume is adjusted to 100 ml with hexane. This stock solution contains:

6.5 ng/μl of Aroclor 1254

Preparation of the working solution:

1 ml from this stock solution should be transferred into a 50 ml volumetric flask and the volume adjusted to 50 ml with hexane. This working solution contains :

0.13 ng/μl of Aroclor 1254

CAUTION : VIAL SHOULD BE COOLED TO 20 °C PRIOR TO OPENING

Preparation of the Aroclor 1260 solution

Preparation of the stock solution:

1 ml from the original vial should be transferred into a 100 ml volumetric flask, then the volume is adjusted to 100 ml with hexane. This solution contains:

5.44 ng/μl of Aroclor 1260

Preparation of the working solution:

1 ml from the stock solution should be transferred into a 50 ml volumetric flask, then the volume is adjusted to 50 ml with hexane. This working solution contains

0.1088 ng/μl of Aroclor 1260

CAUTION: VIAL SHOULD BE COOLED TO 20 °C PRIOR TO OPENING

Preparation of the pp' DDE, pp' DDD and pp' DDT solution

pp' DDE:

Stock solution: 1 ml from the original vial should be transferred into a 100 ml volumetric flask, then the volume is adjusted to 100 ml with hexane. This stock solution contains:

5 ng/μl of pp' DDE

pp' DDD:

Stock solution: 1 ml from the original vial should be transferred into a 100 ml volumetric flask, then the volume is adjusted to 100 ml with hexane. This solution contains:

5 ng/μl of pp' DDD

pp' DDT:

Stock solution: 1 ml of the original vial should be transferred into a 100 ml volumetric flask, then the volume is adjusted to 100 ml with hexane. This stock solution contains:

5 ng/μl of pp' DDT

Working solution: pp' DDE, pp' DDD and pp' DDT together.

1 ml from the stock solution of pp' DDE, 2 ml of the stock solution of pp' DDD and 3 ml of the stock solution of pp' DDT should be transferred into a 100 ml volumetric flask and the volume adjusted to 100 ml with hexane. This solution contains

- pp' DDE : 50 pg/μl
- pp' DDD : 100 pg/μl
- pp' DDT : 150 pg/μl

NOTE: Further dilution may be necessary depending on the sensitivity of the EC Detector.

CAUTION: VIAL SHOULD BE COOLED TO 20 °C PRIOR TO OPENING

Preparation of Aldrin, Dieldrin and Endrin standard solutions:

Aldrin:

Stock solution: 1 ml from the original vial should be transferred into a 100 ml volumetric flask, then the volume is adjusted to 100 ml with hexane. This solution contains:

5 ng/μl of Aldrin

Dieldrin:

Stock solution: 1 ml from the original vial should be transferred into a 100 ml volumetric flask, then the volume is adjusted to 100 ml with hexane. This solution contains:

5 ng/μl of Dieldrin

Endrin:

Stock solution: 1 ml from the original vial should be transferred into a 100 ml volumetric flask, then the volume is adjusted to 100 ml with hexane. This solution contains:

5 ng/μl of Endrin

Working solution: Aldrin, Dieldrin and Endrin together.

1 ml from the stock solution of Aldrin, 1 ml from the stock solution of Dieldrin and 1 ml from the stock solution of Endrin are transferred into a 100 ml volumetric flask and the volume is adjusted to 100 ml with hexane. This working solution contains:

Aldrin : 50 pg/μl
Dieldrin : 50 pg/μl
Endrin : 50 pg/μl

NOTE: Further dilution may be necessary depending on the sensitivity of the detector.

CAUTION: VIALS SHOULD BE COOLED TO 20 °C PRIOR TO OPENING

Preparation of the HCB and Lindane standard solutions:

HCB:

Stock solution: 1 ml from the original vial should be transferred into a 100 ml volumetric flask, then the volume is adjusted to 100 ml with hexane. This solution contains:

5 ng/μl of HCB

Lindane:

Stock solution: 1 ml from the original vial should be transferred into a 100 ml volumetric flask, then the volume is adjusted to 100 ml with hexane. This solution contains:

5 ng/μl of lindane

Working solution:

1 ml from the stock solution of HCB and 1 ml from the stock solution of Lindane are transferred into a 100 ml volumetric flask, then the volume is adjusted to 100 ml with hexane. This solution contains:

HCB : 50 pg/μl

Lindane : 50 pg/μl

NOTE: further dilution may be necessary depending on the sensitivity of the EC Detector.

CAUTION: VIALS SHOULD BE COOLED TO 20 °C PRIOR TO OPENING

Preparation of the PCB congeners solution

In a 100 ml volumetric flask, transfer 1 ml from the original vial. Adjust to 100 ml with hexane in order to obtain the working solution with the following concentrations:

CB N°:	Compounds:	Concentrations (pg/μl)
8	2,4'	17.50
18	2,2',5	12
31	2,4',5	10.6
28	2,4,4'	4.6
52	2,2',5,5'	8.6
49	2,2',4,5'	12.1
44	2,2',3,5'	10.7
66	2,3',4,4'	5.5
95	2,2',3,5',6	5.7
101	2,2',4,5,5'	9.3
110	2,3,3',4',6	11.1
149	2,2',3,4',5',6	12.1
118	2,3',4,4',5	8.5
153	2,2',4,4',5,5'	8.4
138	2,2',3,4,4',5'	13.8
183	2,2',3,4,4',5',6	10.3
174	2,2',3,3',4',5,6'	9.4
177	2,2',3,3',4',5,6	9.5
180	2,2',3,4,4',5,5'	16.3
170	2,2',3,3',4,4',5	13.4
199	2,2',3,3',4,5,5',6'	9.3
194	2,2',3,3',4,4',5,5'	12.6

Separate into 10 volumetric flasks of 10 ml, seal with Teflon tape and keep in refrigerated place in order not to evaporate them.

CAUTION: VIAL SHOULD BE COOLED TO 20 °C PRIOR TO OPENING

EUNOCI 221-02937-0, E05 SED @ BHIMADZU

14:241	15.223	15.961	17.859	18.88	21.880	21.728	22.598	25.850	27.665	48.812	48.873	44.546	45.661	50.523	8	54.133	18	56.927	31	58.927	28	52.791	52	68.927	49	62.227	44	62.877	66 + 95	68.511	101	68.326	110	71.267	118	72.791	153	74.828	183	76.194	174	78.194	177	80.298	180	82.178	199	84.751	194	86.664	194
--------	--------	--------	--------	-------	--------	--------	--------	--------	--------	--------	--------	--------	--------	--------	---	--------	----	--------	----	--------	----	--------	----	--------	----	--------	----	--------	---------	--------	-----	--------	-----	--------	-----	--------	-----	--------	-----	--------	-----	--------	-----	--------	-----	--------	-----	--------	-----	--------	-----

Issued and printed by

Oceans and Coastal Areas Programme Activity Centre
United Nations Environment Programme

Additional copies of this and other publications issued by
the Oceans and Coastal Areas Programme Activity Centre
can be obtained from:

Oceans and Coastal Areas Programme Activity Centre
United Nations Environment Programme
P.O. Box 30552
Nairobi
Kenya

Or from:

Marine Environmental Studies Laboratory
International Atomic Energy Agency
Environment Laboratories
4 Quai Antoine 1^{er}
98000 MONACO

Annex XV:

HELCOM

**Manual for marine monitoring in the COMBINE programme
ANNEX B-12, APPENDIX 3. TECHNICAL NOTE ON THE DETERMINATION OF
CHLORINATED BIPHENYLS AND ORGANOCHLORINE PESTICIDES IN BIOTA**

HELCOM Manual for marine monitoring in the COMBINE programme

ANNEX B-12, APPENDIX 3. TECHNICAL NOTE ON THE DETERMINATION OF CHLORINATED BIPHENYLS AND ORGANOCHLORINE PESTICIDES IN BIOTA

1. INTRODUCTION

The analysis of chlorinated biphenyls (CBs) and organochlorine pesticides (OCPs) in fish samples generally involves extraction from the respective matrix with organic solvents, followed by clean-up and gas chromatographic separation with electron capture (GC-ECD) or mass spectrometric (GC-MS) detection.

The analytical procedure is liable to systematic errors due to insufficiently optimized gas chromatographic conditions, determinant losses (evaporation, unsatisfactory extraction yield), and/or contamination from laboratory ware, reagents and the laboratory environment. It is therefore essential that the sources of systematic errors are identified and eliminated as far as possible.

In the following paragraphs, the guidelines drafted by the OSPAR Ad Hoc Working Group on Monitoring (OSPAR, 1996) have been taken into consideration.

2. PRE-TREATMENT OF LABORATORY WARE AND REAGENTS; CONTAMINATION CONTROL

Glassware, reagents, solvents, column adsorption materials and other laboratory equipment that come into contact with the sample material to be analysed should be free of impurities that interfere with the quantitative determination of CBs and OCPs.

For cleaning purposes, the following procedures should be followed:

1. Glassware should be thoroughly washed with detergents, dried with acetone and rinsed with a non-polar solvent such as *n*-pentane, and heated to > 100 °C prior to use.
2. Glass fibre Soxhlet thimbles should be pre-extracted with an organic solvent. The use of paper Soxhlet thimbles should be avoided. Alternatively, glass fibre thimbles or full glass Soxhlet thimbles, with a G1 glass filter at the bottom, are recommended.
3. Solvents should be checked for impurities using GC after concentrating the volume normally used in the procedure to 10 % of the final volume. If necessary, solvents can be purified by controlled re-distillation and rectification over KOH in an all-glass distillation column.
4. Reagents and column adsorption materials should be checked for contamination before use by extraction with an organic solvent (e.g., *n*-pentane) and analysis by GC, using the detector which will also be used for the final determination (ECD or MS).
5. Laboratory air can also be contaminated with CBs, OCPs or compounds interfering with the CB/OCP analysis. A good estimation of the contamination of the air can be found by placing a petri dish with 2 grams of C18-bonded silica for two weeks in the laboratory. After this period, the material is transferred to a glass column and eluted with 10 ml of 10% diethylether in hexane. After concentrating the eluate, the CB concentrations can be measured. Absolute amounts of <1 ng show that the contamination of the air is at an acceptably low level in that laboratory (Smedes and de Boer, 1994).

3. SAMPLE PRETREATMENT

To ensure complete extraction of the lipophilic CBs and OCPs from biological sample matrices, it is essential to dry the material and disrupt the cell walls of the biological matrix to be analysed. This can be achieved by Ultra Turrax mixing or grinding of the sample with a dehydrating reagent, such as Na₂SO₄, followed by multiple solid/liquid extraction with a mixture of polar and non-polar solvents (e.g., acetone/hexane or methanol/dichloromethane). It is essential to allow complete binding of the water present in the sample with the dehydrating reagent (this requires at least several hours) prior to starting the extraction step. The extraction efficiency must be checked for different types and amounts of biological matrices to be investigated (see 'recovery section').

4. CLEAN-UP

The crude extract obtained from sample pretreatment requires a clean-up in order to remove co-extracted lipophilic compounds that interfere with the gas chromatographic determination of CBs and OCPs. Normal-phase solid/liquid chromatography, using deactivated Al₂O₃ or deactivated silica as adsorbents and hexane or iso-octane as solvents, is an appropriate technique for the separation of the determinands from lipids or other interfering compounds. Effective removal of high molecular weight compounds can be achieved by gel permeation chromatography (GPC). However, GPC does not separate CBs from other compounds in the same molecular range, such as organochlorine pesticides (OCPs). Therefore, additional clean-up may be required. Treatment of the OCP fraction with concentrated H₂SO₄ can improve the quality of the subsequent gas chromatogram. However, this treatment is not recommended if determinands of the dieldrin type or heptachloroepoxides, which are easily broken down by H₂SO₄, are to be determined.

5. DETERMINATION BY GAS CHROMATOGRAPHY

Because of the large number of organochlorine compounds to be determined, high resolution gas chromatography (GC) using, preferably narrow bore, fused silica wall-coated open-tubular (capillary) columns is necessary.

Carrier gas

Hydrogen is the preferred carrier gas and is indispensable for columns with very small inner diameters. For safety reasons, hydrogen should not be used without a safety module which is able to check for small hydrogen concentrations inside the GC oven coming from possible leakages. As a compromise to safety aspects, helium is also acceptable.

Columns

In order to achieve sufficient separation, capillary columns should have a length of >60 m, an internal diameter of < 0.25 mm (for diameters below 0.18 mm the elevated pressure of the carrier gas needs special instrumentation) and a film thickness of the stationary phase of < 0.25 µm. For routine work, the SE 54 (Ultra 2, DB 5, RTx 5, CP-Sil 8) phase (94 % dimethyl-, 5 % phenyl-, 1 % vinyl-polysiloxane) or medium polar columns (CP-Sil 19, OV-17, OV 1701, DB 17) have been shown to give satisfactory chromatograms. A second column with a stationary phase different, from that used in the first column, may be used for confirmation of the peak identification.

Injection

Splitless and on-column injection techniques may both be used. Split injection is not recommended because strong discrimination effects may occur. Other techniques such as temperature-programmed or pressure-programmed injection may have additional advantages, but should be thoroughly optimized before use.

In splitless injection, the volume of the liner should be large enough to contain the gas volume of the evaporated injected solvent. If the liner is too small, memory effects can occur due to contamination of the gas tubing attached to the injector. Very large liner volumes, in contrast, can cause a poor transfer of early eluting components.

A 1 µl injection normally requires a ca. 1 ml liner. The occurrence of memory effects should be tested by injection of iso-octane after analysis of a CB or OCP standard. The use of a light packing of silylated glass wool in the liner improves the response and reproducibility of the injection. However, some organochlorine pesticides such as DDT may disintegrate when this technique is used. In splitless injection, discrimination effects can occur.

The splitless injection time should therefore be optimized to avoid discrimination. This can be done by injecting a solution containing an early-eluting and a late-eluting CB, e.g., CB28 and CB180. Starting with a splitless injection time of 0.5 minutes, the peak height of the late-eluting compound will presumably increase relative to that of the first compound. The optimum is found at the time when the increase does not continue any further. The split ratio is normally set at 1:25 and is not really critical. The septum purge, normally approximately 2 ml min⁻¹, should be stopped during injection. This option is not standard in all GCs.

Due to the variety of on-column injectors, a detailed optimization procedure cannot be given. More information on the optimization of on-column parameters may be obtained from Snell *et al.* (1987).

The reproducibility of injection is controlled by the use of an internal standard not present in the sample.

Detector

Quantitative analysis is performed by comparing the detector signal produced by the sample with that of defined standards. The use of an electron capture detector (ECD) sensitive to chlorinated compounds or - more generally applicable - a mass selective detector (MSD) or (even) a mass spectrometer (MS) is essential.

Due to incomplete separation, several co-eluting compounds can be present under a single detector signal. Therefore, the shape and size of the signal have to be critically examined. With a MSD or MS used as detector, either the molecular mass or characteristic mass fragments should be recorded for that purpose. If only an ECD is available, the relative retention time and the signal size should be confirmed on columns with different polarity of their stationary phases, or by the use of multi-dimensional GC techniques (de Boer *et al.*, 1995; de Geus *et al.*, 1996).

Calibration

Stock solutions of individual organohalogen compounds should be prepared using iso-octane as the solvent and weighed solid individual standard compounds of high purity (> 99 %). Stock solutions can be stored in measuring flasks in a refrigerator or in a dessicator with a saturated atmosphere of iso-octane, but losses can easily occur, particularly when storing in refrigerators (Law and de Boer, 1995). Loss of solvents in stock solutions can be controlled by recording the weight and filling up the missing amount before a new aliquot is taken. However, aliquots stored in sealed glass ampoules are much more appropriate and can normally be stored for several years. Fresh stock standard solutions should be prepared in duplicate and compared with the old standard solutions. Working standards should be prepared gravimetrically from stock solutions for each sample series. All manipulations with solvents, including pipetting, diluting and concentrating, should preferably be checked by weighing. Due to day-to-day and season-to-season temperature differences in laboratories and due to the heating of glassware after cleaning, considerable errors can be made when using volumetric glassware as a basis for all calculations.

The GC should be calibrated before each batch of measurements. Since the ECD has a non-linear response curve, a multilevel calibration is strongly advised. Megginson *et al.* (1994) recommend a set of six standard solutions for CB determination or five standard solutions for OCP determination. Standards used for multilevel calibration should be regularly distributed over the sample series, so that matrix and non-matrix containing injections alternate. When concentrations of compounds in the sample fall outside either side of the calibration curve, a new dilution or concentrate should be made and the measurement repeated. Considerable errors can be made when measuring concentrations which fall outside the calibration curve.

For MS detection, a multi-level calibration is also recommended.

Recovery

For the purpose of determining recovery rates, an appropriate internal standard should be added to each sample at the beginning of the analytical procedure. The ideal internal standard is a CB which is not present in the sample and which does not interfere with other CBs. All 2,4,6-substituted CB congeners are, in principle, suitable. Alternatively, 1,2,3,4-tetrachloronaphthalene or the homologues of dichloroalkylbenzylether can be used. For GC with mass selective detection (GC-MSD), ¹³C-labelled CBs must be used as internal standards. With GC/MS, ¹³C-labelled CBs should preferably be used as internal standards.

6. REFERENCES

- de Boer, J., and Dao, Q.T. 1991. Analysis of seven chlorobiphenyl congeners by multidimensional gas chromatography. *Journal of High Resolution Chromatography*, 14: 593-596.
- de Boer, J., Dao, Q.T., Wester, P.G., Bøwadt, S., and Brinkman, U.A.Th. 1995. Determination of mono-*ortho* substituted chlorobiphenyls by multidimensional gas chromatography and their contribution to TCDD equivalents. *Analytica Chimica Acta*, 300: 155-165.
- de Geus, H.-J., de Boer, J., and Brinkman, U.A.Th. 1996. Multidimensionality in gas chromatography. *Trends in Analytical Chemistry*, 15: 398-408.
- Law, R.J., and de Boer, J. 1995. Quality assurance of organic compounds in marine matrices: application to analysis of chlorobiphenyls and polycyclic aromatic hydrocarbons. *In Quality assurance in environmental monitoring*, pp. 129-155. Edited by Ph. Quevauviller. VCH, Weinheim, Germany.
- Megginson, C., McKenzie, C., and Wells, D. 1994. Practical steps to improve the quality control of the chromatography for chlorobiphenyl and organochlorine pesticide analysis. *Marine Pollution Bulletin*, 29: 228-234.
- OSPAR. 1996. Ad Hoc Working Group on Monitoring (MON). Draft JAMP Biota Monitoring Guidelines. Doc. MON 96/9/1, Annex 5. OSPAR Commission, London, UK.
- Smedes, F., and de Boer, J. 1994. Guidelines for the determination of chlorobiphenyls in sediments. *Quimica Analytica*, 13: S100-S108.
- Snell, R.P., Danielson, J.W., and Oxborrow, G.W. 1987. Parameters affecting the quantitative performance of cold on-column and splitless injection systems used in capillary gas chromatography. *Journal of Chromatography Science*, 25: 225-230.

Annex XVI:

HELCOM

**Manual for marine monitoring in the COMBINE programme
ANNEX B-12, APPENDIX 2. TECHNICAL NOTE ON THE DETERMINATION OF
POLYCYCLIC AROMATIC HYDROCARBONS IN BIOTA**

HELCOM Manual for marine monitoring in the COMBINE programme

ANNEX B-12, APPENDIX 2. TECHNICAL NOTE ON THE DETERMINATION OF POLYCYCLIC AROMATIC HYDROCARBONS IN BIOTA

1. INTRODUCTION

Polycyclic aromatic hydrocarbons (PAHs) consist of a variable number of fused aromatic rings. By definition, PAHs contain at least three fused rings, although in practice related compounds with two fused rings (such as naphthalene and its alkylated derivatives) are often determined and will be considered in these guidelines. PAHs arise from incomplete combustion processes and from both natural and anthropogenic sources, although the latter generally predominate. PAHs are also found in oil and oil products, and these include a wide range of alkylated PAHs formed as a result of diagenetic processes, whereas PAHs from combustion sources comprise mainly parent (non-alkylated) PAHs. PAHs are of concern in the marine environment for two main reasons: firstly, low-molecular weight (MW) PAHs can be directly toxic to marine animals; secondly, metabolites of some of the high-MW PAHs are potent animal and human carcinogens, benzo[a]pyrene is the prime example. Carcinogenic activity is closely related to structure, however, and benzo[e]pyrene and four benzofluoranthene isomers (all six compounds have a molecular weight of 252 Da) are much less potent. Some compounds (e.g., heterocyclic compounds containing sulphur, such as benzothiophenes and dibenzo-thiophenes) may also cause taint in commercially exploited fish and shellfish and render them unfit for sale. PAHs are readily taken up by marine animals both across gill surfaces and from their diet, and may bioaccumulate, particularly in shellfish. Filter-feeding organisms such as bivalve molluscs can accumulate high concentrations of PAHs, both from chronic discharges to the sea (e.g., of sewage) and following oil spills. Fish are exposed to PAHs both via uptake across gill surfaces and from their diet, but do not generally accumulate high concentrations of PAHs as they possess an effective mixed-function oxygenase (MFO) system which allows them to metabolize PAHs and to excrete them in bile. An assessment of the exposure of fish to PAHs therefore requires also the determination of PAH-metabolite concentrations in bile samples, as turnover times can be extremely rapid. Thus, the analysis of PAHs in fish muscle tissue should normally only be undertaken for food quality assurance purposes (Law and Biscaya, 1994).

There are marked differences in the behaviour of PAHs in the aquatic environment between the low-MW compounds (such as naphthalene; 128 Da) and the high-MW compounds (such as benzo[ghi]perylene; 276 Da) as a consequence of their differing physico-chemical properties. The low-MW compounds are appreciably water soluble and can be bioaccumulated from the "dissolved" phase by transfer across gill surfaces, whereas the high-MW compounds are relatively insoluble and hydrophobic, and can attach to both organic and inorganic particulates within the water column. PAHs derived from combustion sources may actually be deposited to the sea already adsorbed to atmospheric particulates, such as soot particles. The majority of PAHs in the water column will eventually be either taken up by biota or transported to the sediments, and deep-water depositional areas may generally be regarded as sinks for PAHs, particularly when they are anoxic.

2. APPROPRIATE SPECIES FOR ANALYSIS OF PAHS

2.1 Benthic fish and shellfish

All teleost fish have the capacity for rapid metabolism of PAHs, thereby limiting their usefulness for monitoring temporal or spatial trends of PAHs. Shellfish (particularly molluscs) generally

have a lesser metabolic capacity towards PAHs, and so they are preferred because PAH concentrations are generally higher in their tissues.

For the purposes of temporal trend monitoring, it is essential that long time series with either a single species or a limited number of species are obtained. Care should be taken that the sample is representative of the population and that sampling can be repeated annually. There are advantages in the use of molluscs for this purpose as they are sessile, and so reflect the degree of contamination in the local area to a greater degree than fish which are mobile. The analysis of fish tissues is often undertaken in conjunction with biomarker and disease studies, and associations have been shown between the incidence of some diseases (e.g., liver neoplasia) in flatfish and the concentrations of PAHs in the sediments over which they live and feed (Malins et al., 1988; Vethaak and Rheinallt, 1992). The exposure of fish to PAHs can be assessed by the analysis of PAH-metabolites in bile, and by measuring the induction of mixed-function oxygenase enzymes which affect the formation of these metabolites. At offshore locations, the collection of appropriate shellfish samples may be problematic if populations are absent, sparse or scattered, and the collection of fish samples may be simpler. Generally, the analysis of PAHs in fish muscle tissue should only be considered for the purposes of food quality assurance.

Recent monitoring studies have indicated a seasonal cycle in PAH concentrations (particularly for combustion-derived PAHs) in mussels, with maximum concentrations in the winter prior to spawning and minimum concentrations in the summer. It is particularly important, therefore, that samples selected for trend monitoring and spatial comparisons are collected at the same time of year, and preferably in the first months of the year before spawning.

2.2 Fish

Fish are not recommended for spatial or temporal trend monitoring of PAHs, but can be useful as part of biological effects studies or for food quality assurance purposes. The sampling strategy for biological effects monitoring is described in the OSPAR Joint Assessment and Monitoring Programme (JAMP).

3. TRANSPORTATION

Live mussels should be transported to the laboratory for sample preparation. They should be transported in closed containers at temperatures between 5 °C and 15 °C, preferably below 10 °C. For live animals it is important that the transport time is short and controlled (e.g., maximum of 24 hours).

Fish samples should be kept cool or frozen (at a temperature of -20 °C or lower) as soon as possible after collection. Frozen fish samples should be transported in closed containers at temperatures below -20 °C. If biomarker determinations are to be made, then it will be necessary to store tissue samples at lower temperatures, for example, in liquid nitrogen at -196 °C.

4. PRETREATMENT AND STORAGE

4.1 Contamination

Sample contamination may occur during sampling, sample handling, pretreatment and analysis, due to the environment, the containers or packing materials used, the instruments used during sample preparation, and from the solvents and reagents used during the analytical procedures. Controlled conditions are therefore required for all procedures, including the dissection of fish organs on-board a ship (see ANNEX B-13, Appendix 1). In the case of PAHs, particular care must be taken to avoid contamination at sea. On ships there are multiple sources of PAHs, such as the

oils used for fuel and lubrication, and the exhaust from the ship's engines. It is important that the likely sources of contamination are identified and steps taken to preclude sample handling in areas where contamination can occur. A ship is a working vessel and there can always be procedures occurring as a result of the day-to-day operations (deck cleaning, automatic overboard bilge discharges, etc.) which could affect the sampling process. One way of minimizing the risk is to conduct dissection in a clean area, such as within a laminar-flow hood away from the deck areas of the vessel. It is also advisable to collect samples of the ship's fuel, bilge water, and oils and greases used on winches, etc., which can be used as fingerprinting samples at a later date, if there are suspicions of contamination in particular instances.

4.2 Shellfish

4.2.1 Depuration

Depending upon the situation, it may be desirable to depurate shellfish so as to void the gut contents and any associated contaminants before freezing or sample preparation. This is usually applied close to point sources, where the gut contents may contain significant quantities of PAHs associated with food and sediment particles which are not truly assimilated into the tissues of the mussels. Depuration should be undertaken under controlled conditions and in filtered sea water; depuration over a period of 24 hours is usually sufficient. The aquarium should be aerated and the temperature and salinity of the water should be similar to that from which the animals were removed.

4.2.2 Dissection and storage

When samples are processed, both at sea and onshore, the dissection must be undertaken by trained personnel on a clean bench wearing clean gloves and using clean stainless steel knives and scalpels. Stainless steel tweezers are recommended for holding tissues during dissection. After each sample has been prepared, all tools and equipment (such as homogenizers) should be cleaned.

4.3 Fish

4.3.1 Dissection and storage

The dissection of fish muscle and internal organs should be carried as soon as possible after collection. The details of fish muscle and liver dissection are given in ANNEX B-13, Appendix 1. If possible, the entire right side dorsal lateral fillet should be homogenized and sub samples taken for replicate PAH determinations. If, however, the amount of material to be homogenized would be too large, a specific portion of the dorsal musculature should be chosen. It is recommended that the portion of the muscle lying directly under the first dorsal fin is used in this case.

When dissecting the liver, care should be taken to avoid contamination from the other organs. If bile samples are to be taken for PAH-metabolite determinations, then they should be collected first. If the whole liver is not to be homogenized, a specific portion should be chosen in order to ensure comparability. Freeze-drying of tissue samples cannot be recommended for PAH determination, due to the contamination which may result from back-streaming of oil from the rotary pumps used to generate the vacuum.

If plastic bags or boxes are used, then they should be used as outer containers only, and should not come into contact with tissues. Organ samples (e.g., livers) should be stored in pre-cleaned containers made of glass, stainless steel or aluminium, or should be wrapped in pre-cleaned aluminium foil and shock-frozen quickly in liquid nitrogen or in a blast freezer. In the latter case, care should be taken that the capacity of the freezer is not exceeded (Law and de Boer,

1995). Cold air should be able to circulate between the samples in order that the minimum freezing time can be attained (maximum 12 hours). The individual samples should be clearly and indelibly labelled and stored together in a suitable container at a temperature of -20 °C until analysis. If the samples are to be transported during this period (e.g., from the ship to the laboratory), then arrangements must be made which ensure that the samples do not thaw out during transport. Sub samples for biomarker determinations should be collected immediately after death in order to minimize post-mortem changes in enzymatic and somatic activities, and stored in suitable vials in liquid nitrogen until analysis.

When samples are processed, both at sea and onshore, the dissection must be undertaken by trained personnel on a clean bench wearing clean gloves and using clean stainless steel knives and scalpels. Stainless steel tweezers are recommended for holding tissues during dissection. After each sample has been prepared, all tools and equipment (such as homogenizers) should be cleaned.

When pooling of tissues is necessary, an equivalent quantity of tissue should be taken from each fish, e.g., 10 % from each whole fillet.

5. ANALYSIS

5.1 Preparation of materials

Solvents, reagents, and adsorptive materials must be free of PAHs and other interfering compounds. If not, then they must be purified using appropriate methods. Reagents and absorptive materials should be purified by solvent extraction and/or by heating in a muffle oven, as appropriate. Glass fibre materials (e.g., Soxhlet thimbles) are preferred over filter papers and should be cleaned by solvent extraction. It should be borne in mind that clean materials can be re-contaminated by exposure to laboratory air, particularly in urban locations, and so storage after cleaning is of critical importance. Ideally, materials should be prepared immediately before use, but if they are to be stored, then the conditions should be considered critically. All containers which come into contact with the sample should be made of glass, and should be pre-cleaned before use. Appropriate cleaning methods would include washing with detergents, rinsing with water, and finally solvent-rinsing immediately before use. Heating of glassware in an oven (e.g., at 400°C for 24 hours) can also be useful in removing PAH contamination.

5.2 Lipid determination

Although PAH data are not usually expressed on a lipid basis, the determination of the lipid content of tissues can be of use in characterizing the samples. The lipid content should be determined on a separate subsample of the tissue homogenate, as some of the extraction techniques used routinely for PAH determination (e.g., alkaline saponification) destroy lipid materials. The total fat weight should be determined using the method of Smedes (1999) or an equivalent method.

5.3 Dry weight determination

Generally PAH data are expressed on a wet weight basis, but sometimes it can be desirable to consider them on a dry weight basis. Again, the dry weight determination should be conducted on a separate sub sample of the tissue homogenate, which should be air-dried to constant weight at 105 °C.

5.4 Extraction and clean-up

PAHs are lipophilic and so are concentrated in the lipids of an organism, and a number of methods have been described for PAH extraction (see, e.g., Ehrhardt *et al.*, 1991). The preferred methods generally utilize either Soxhlet extraction, or alkaline digestion followed by liquid-liquid extraction with an organic solvent. Microwave-assisted solvent extraction can be mentioned as one of the modern techniques being applied to PAH analysis (Budzinski *et al.*, 2000; During and Gaath, 2000; Vázquez Blanco *et al.*, 2000; Ramil Criado *et al.*, 2002). In the case of Soxhlet extraction, the wet tissue must be dried by mixing with a chemical agent (e.g., anhydrous sodium sulphate), in which case a time period of several hours is required between mixing and extraction in order to allow complete binding of the water in the sample. Alkaline digestion is conducted on wet tissue samples, so this procedure is unnecessary. In neither case can the freeze-drying of the tissue prior to extraction be recommended, owing to the danger of contamination from oil back-streaming from the rotary pump (which provides the vacuum) into the sample. Non-polar solvents alone will not effectively extract all the PAHs from tissues when using Soxhlet extraction, and mixtures such as hexane/dichloromethane may be effective in place of solvents such as benzene and toluene, used historically for this purpose. Alkaline digestion has been extensively used in the determination of PAHs and hydrocarbons and is well documented. It is usually conducted in alcohol (methanol or ethanol), which should contain at least 10 % water, and combines disruption of the cellular matrix, lipid extraction and saponification within a single procedure, thereby reducing sample handling and treatment. For these reasons, it should be the method of choice. Solvents used for liquid-liquid extraction of the homogenate are usually non-polar, such as pentane or hexane, and they will effectively extract all PAHs.

Tissue extracts will always contain many compounds other than PAHs, and a suitable clean-up is necessary to remove those compounds which may interfere with the subsequent analysis. Different techniques may be used, both singly or in combination, and the choice will be influenced by the selectivity and sensitivity of the final measurement technique and also by the extraction method employed. If Soxhlet extraction was used, then there is a much greater quantity of residual lipid to be removed before the analytical determination can be made than in the case of alkaline digestion. An additional clean-up stage may therefore be necessary. The most commonly used clean-up methods involve the use of alumina or silica adsorption chromatography, but gel permeation chromatography and similar high performance liquid chromatography (HPLC) based methods are also employed (Nondek *et al.*, 1993; Nyman *et al.*, 1993; Perfetti *et al.*, 1992). The major advantages of using HPLC-based clean-up methods are their ease of automation and reproducibility.

5.5 Pre-concentration

The sample volume should be 2 cm³ or greater to avoid errors when transferring solvents during the clean-up stages. Evaporation of solvents using a rotary-film evaporator should be performed at low temperature (water bath temperature of 30 °C or lower) and under controlled pressure conditions, in order to prevent losses of the more volatile PAHs such as naphthalenes. For the same reasons, evaporation to dryness should be avoided. When reducing the sample to final volume, solvents can be removed by a stream of clean nitrogen gas. Suitable solvents for injection into the gas chromatograph (GC) or GC-MS include pentane, hexane, heptane and *iso*-octane, whereas for HPLC analyses acetonitrile and methanol are commonly used.

5.6 Selection of PAHs to be determined

The choice of PAHs to be analysed is not straightforward, both because of differences in the range of PAH compounds resulting from combustion processes and from oil and oil products, and also because the aims of specific monitoring programmes can require the analysis of different representative groups of compounds. PAHs arising from combustion processes are predominantly parent (unsubstituted) compounds, whereas oil and its products contain a much

wider range of alkylated compounds in addition to the parent PAHs. This has implications for the analytical determination, as both HPLC-based and GC-based techniques are adequate for the determination of a limited range of parent PAHs in samples influenced by combustion processes, whereas in areas of significant oil contamination and following oil spills only GC-MS has sufficient selectivity to determine the full range of PAHs present. The availability of pure individual PAHs for the preparation of standards is problematic and limits both the choice of determinands and, to some degree, the quantification procedures which can be used. The availability of reference materials certified for PAHs is also rather limited. A list of target parent and alkylated PAHs suitable for environmental monitoring is given in Table 1. In both cases, the list was concentrated on a subset of parent (predominantly combustion-derived) PAHs due to analytical limitations. This approach completely neglects the determination of alkylated PAHs, which allows the interpretation of PAH accumulation from multiple sources including those due to oil inputs. It will not be necessary for all of these PAH compounds and groups to be analysed in all cases, but an appropriate selection can be made from this list depending on the specific aims of the monitoring programme to be undertaken.

Table 1: Compounds of interest for environmental monitoring for which the guidelines apply			
Compound	MW	Compound	MW
Naphthalene	128	C2-Phenanthrenes/Anthracenes	206
C1-Naphthalenes	142	C3-Phenanthrenes/Anthracenes	220
C2-Naphthalenes	156	Fluoranthene	202
C3-Naphthalenes	170	Pyrene	202
C4-Naphthalenes	184	C1-Fluoranthenes/Pyrenes	216
Acenaphthylene	152	C2-Fluoranthenes/Pyrenes	230
Acenaphthene	154	Benz[a]anthracene	228
Biphenyl	154	Chrysene	228
Fluorene	166	2,3-Benzanthracene	228
C1-Fluorenes	180	Benzo[a]fluoranthene	252
C2-Fluorenes	194	Benzo[b]fluoranthene	252
C3-Fluorenes	208	Benzo[j]fluoranthene	252
Dibenzothiophene	184	Benzo[k]fluoranthene	252
C1-Dibenzothiophenes	198	Benzo[e]pyrene	252
C2-Dibenzothiophenes	212	Benzo[a]pyrene	252
C3-Dibenzothiophenes	226	Perylene	252
Phenanthrene	178	Indeno[1,2,3-cd]pyrene	276
Anthracene	178	Benzo[ghi]perylene	276
C1-Phenanthrenes/ Anthracenes	192	Dibenz[ah]anthracene	278

5.7 Instrumental determination of PAHs

Unlike the situation for chlorobiphenyls (CBs), where GC techniques (particularly GC-ECD) are used exclusively, two major approaches based on GC and HPLC are followed to an equal extent in the analysis of PAHs. The greatest sensitivity and selectivity in routine analyses are achieved by combining HPLC with fluorescence detection (HPLC-UVF) and capillary gas chromatography with mass spectrometry (GC-MS). In terms of flexibility, GC-MS is the most capable technique, as in principle it does not limit the selection of determinands in any way, while HPLC is suited only to the analysis of parent PAHs. In the past, analyses have also been conducted using HPLC with UV-absorption detection and GC with flame-ionization detection, but neither can be recommended because of their relatively poor selectivity.

Intercomparison exercises have demonstrated a serious lack of comparability between specific hydrocarbon concentrations measured in different laboratories and using both analytical approaches described above (Farrington *et al.*, 1986). An interlaboratory performance study has been carried out within the QUASIMEME laboratory testing scheme in order to assess the level of comparability among laboratories conducting PAH analyses and to identify improvements in methodology (Law and Klungsøyr, 1996; Law *et al.*, 1998, QUASIMEME). Limits of determination within the range of 0.2 to 10 µg kg⁻¹ wet weight for individual PAH compounds should be achievable by both GC-MS and HPLC-UVF techniques.

5.8 HPLC

Reversed-phase columns (e.g., octadecylsilane (RP-18)) 15–30 cm in length are used almost exclusively, in conjunction with gradient elution using mixtures of acetonitrile/water or methanol/water. A typical gradient may start as a 50 % mixture, changing to 100 % acetonitrile or methanol in 40 minutes. This flow is maintained for 20 minutes, followed by a return to the original conditions in 5 minutes and 5–10 minutes' equilibration before the next injection. The use of an automatic injector is strongly recommended. Also, the column should be maintained in a column oven heated to 10–30°C. The systems yielding the best sensitivity and selectivity utilize fluorescence detection. As different PAH compounds yield their maximum fluorescence at different wavelengths, for optimum detection of PAHs the wavelengths of the detector should be programmed so that the excitation/emission wavelengths detected are changed at pre-set times during the analytical determination. For closely eluting peaks, it may be necessary to use two detectors in series utilizing different wavelength pairs, or to affect a compromise in the selected wavelengths if a single detector is used. As the fluorescence signals of some PAHs (e.g., pyrene) are quenched by oxygen, the eluents must be degassed thoroughly. This is usually achieved by continuously bubbling a gentle stream of helium through the eluent reservoirs, but a vacuum degasser can also be used. Polytetrafluorethylene (PTFE) tubing must not then be used downstream of the reservoirs as this material is permeable to oxygen; stainless steel or polyether-etherketone (PEEK) tubing is preferred.

5.9 GC-MS

The two injection modes commonly used are splitless and on-column injection. Automatic sample injection should be used wherever possible to improve the reproducibility of injection and the precision of the overall method. If splitless injection is used, the liner should be of sufficient capacity to contain the injected solvent volume after evaporation. For PAH analysis, the cleanliness of the liner is also very important if adsorption effects and discrimination are to be avoided, and the analytical column should not contain active sites to which PAHs can be adsorbed. Helium is the preferred carrier gas, and only capillary columns should be used. Because of the wide boiling range of the PAHs to be determined and the surface-active properties of the higher PAHs, the preferred column length is 25–30 m, with an internal diameter of 0.15 mm to 0.3 mm. Film thicknesses of 0.3 µm to 1 µm are generally used; this choice has little impact on critical resolution, but thicker films are often used when one-ring aromatic compounds are to be determined alongside PAHs, or where a high sample loading is

needed. No stationary phase has been found on which all PAH isomers can be resolved; the most commonly used stationary phase for PAH analysis is 5 % phenyl methylsilicone (DB-5 or equivalent). This will not, however, resolve critical isomers such as benzo[*b*], [*j*] and [*k*]fluoranthenes, or chrysene from triphenylene. These separations can be made on other columns, if necessary. For PAHs there is no sensitivity gain from the use of chemical ionization (either positive or negative ion), so analyses are usually conducted in electron-impact mode at 70 eV. The choice of full-scan or multiple-ion detection is usually made in terms of sensitivity. Some instruments such as ion-trap mass spectrometers exhibit the same sensitivity in both modes, so full-scan spectra are collected, whereas for quadrupole instruments greater sensitivity is obtained if the number of ions scanned is limited. In that case, the masses to be detected are programmed to change during the analysis as different PAHs elute from the capillary column.

6. CALIBRATION AND QUANTIFICATION

6.1 Standards

A range of fully deuterated parent PAHs is available for use as standards in PAH analysis. The availability of pure PAH compounds is limited (Annex B-7). Although most of the parent compounds can be purchased as pure compounds, the range of possible alkyl-substituted PAHs is vast and only a limited selection of them can be obtained. In HPLC, where the resolving power of the columns is limited and the selectivity less than that which can be obtained using MS detection, only a single internal standard is normally used (e.g., phenanthrene-d10), although fluoranthene-d10 and 6-methyl chrysene, among others, have also been used. If GC-MS is used, then a wider range of deuterated PAHs can be utilized, both because of the wide boiling range of PAHs present and because that allows the use of both recovery and quantification standards. Suitable standards could range from naphthalene-d8 to perylene-d10. It is always recommended to use at least two and preferably three internal standards of hydrocarbons of small, medium, and high molecular weight (e.g., naphthalene-d8, phenanthrene-d10, perylene-d12). Crystalline PAHs of known purity should be used for the preparation of calibration standards. If the quality of the standard materials is not guaranteed by the producer or supplier (as for certified reference materials), then it should be checked by GC-MS analysis. Solid standards should be weighed to a precision of 10⁻⁵ grams. Calibration standards should be stored in the dark because some PAHs are photosensitive, and ideally solutions to be stored should be sealed in amber glass ampoules. Otherwise, they can be stored in a refrigerator in stoppered measuring cylinders or flasks that are gas tight to avoid evaporation of the solvent during storage.

6.2 Calibration

Multilevel calibration with at least five calibration levels is preferred to adequately define the calibration curve. In general, GC-MS calibration is linear over a considerable concentration range but exhibits non-linear behaviour when the mass of a compound injected is low due to adsorption. Quantification should be conducted in the linear region of the calibration curve, or the non-linear region must be well characterized during the calibration procedure. For HPLC-UVF, the linear range of the detection system should be large, and quantification should be made within the linear range. External standardization is often used with HPLC due to the relatively limited resolution obtainable with this technique as generally employed.

6.3 Recovery

The recovery of analytes should be checked and reported. Given the wide boiling range of the PAHs to be determined, the recovery may vary with compound group, from the volatile PAHs of low molecular weight to the larger compounds. For GC-MS analysis, deuterated standards can

be added in two groups: those to be used for quantification are added at the start of the analytical procedure, whilst those from which the absolute recovery will be assessed are added prior to GC-MS injection. This ensures that the calculated PAH concentrations are corrected for the recovery obtained in each case. In the case of HPLC, where only a single deuterated PAH standard is used, it is more common to assess recovery periodically by carrying a standard solution through the whole analytical procedure, then assessing recovery by reference to an external standard. This technique does not, however, correct for matrix effects, and so may be used in conjunction with the spiking of real samples.

7. ANALYTICAL QUALITY CONTROL

Planners of monitoring programmes must decide on the accuracy, precision, repeatability, and limits of detection and determination which they consider acceptable. Achievable limits of determination for each individual component are as follows:

- for GC-MS measurements: 0.2 µg kg⁻¹ ww;
- for HPLC measurements: 0.5–10 µg kg⁻¹ ww.

Further information on analytical quality control procedures for PAHs can be found elsewhere (Law and de Boer, 1995). A procedural blank should be measured with each sample batch, and should be prepared simultaneously using the same chemical reagents and solvents as for the samples. Its purpose is to indicate sample contamination by interfering compounds, which will result in errors in quantification. The procedural blank is also very important in the calculation of limits of detection and limits of quantification for the analytical method. In addition, a laboratory reference material (LRM) should be analysed within each sample batch. Test materials from the former runs of QUASIMEME Laboratory Proficiency Testing can be used as Laboratory Reference Material. The LRM must be homogeneous and well characterized for the determinands of interest within the analytical laboratory. Ideally, stability tests should have been undertaken to show that the LRM yields consistent results over time. The LRM should be of the same matrix type (e.g., liver, muscle, mussel tissue) as the samples, and the determinand concentrations should be in the same range as those in the samples. Realistically, and given the wide range of PAH concentrations encountered, particularly in oil spill investigations, this is bound to involve some compromise. The data produced for the LRM in successive sample batches should be used to prepare control charts. It is also useful to analyse the LRM in duplicate from time to time to check within-batch analytical variability. The analysis of an LRM is primarily intended as a check that the analytical method is under control and yields acceptable precision, but a certified reference material (CRM) of a similar matrix should be analysed periodically in order to check the method bias. The availability of biota CRMs certified for PAHs is very limited (Annex B-7; QUASIMEME), and in all cases the number of PAHs for which certified values are provided is small. At regular intervals, the laboratory should participate in an intercomparison or proficiency exercise in order to provide an independent check on the performance.

8. DATA REPORTING

The calculation of results and the reporting of data can represent major sources of error, as has been shown in intercomparison studies for PAHs. Control procedures should be established in order to ensure that data are correct and to obviate transcription errors. Data stored in databases should be checked and validated, and checks are also necessary when data are transferred between databases. Data should be reported in accordance with the latest ICES reporting formats.

9. REFERENCES

- Vázquez Blanco, E., López Mahía, P., Muniategui Lorenzo, S., Prada Rodríguez, D., and Fernández Fernández, E. 2000. Optimization of microwave-assisted extraction of hydrocarbons in marine sediments: comparison with the Soxhlet extraction method. *Fresenius Journal of Analytical Chemistry*, 366: 283–288.
- Budzinski, H. 2000. Combined protocol for analysis of PAHs and PCBs from sediments using focused microwave assisted (FMW) extraction at atmospheric pressure. *Fresenius Journal of Analytical Chemistry*, 367: 165–171.
- During, R.A., and Gaath, S. 2000. Microwave assisted methodology for the determination of organic pollutants in organic municipal wastes and soils: extraction of PCBs using heat transformer discs. *Fres. J. Anal.Chem.*, 368: 684–688.
- Ehrhardt, M., Klungsøyr, J., and Law, R.J. 1991. Hydrocarbons: Review of methods for analysis in sea water, biota, and sediments. *Techniques in Marine Environmental Sciences*, 12: 19–22.
- Farrington, J.W., Davis, A.C., Livramento, J.B., Clifford, C.H., Frew, N.M., and Knap, A. 1986. ICES/IOC Intercomparison Exercises on the Determination of Petroleum Hydrocarbons in Biological Tissues (mussel homogenate) - ICES (2/HC/BT). ICES Cooperative Research Report, 141: 1–75.
- Law, R.J., and Biscaya, J.L. 1994. Polycyclic aromatic hydrocarbons (PAHs)—Problems and progress in sampling, analysis and interpretation. *Marine Pollution Bulletin*, 29: 235–241.
- Law, R.J., and de Boer, J. 1995. Quality assurance of analysis of organic compounds in marine matrices: Application to analysis of chlorobiphenyls and polycyclic aromatic hydrocarbons. *In Quality Assurance in Environmental Monitoring—Sampling and Sample Pretreatment*, pp. 129–156. Ed. by P. Quevauviller. VCH Publishers, Weinheim, Germany.
- Law, R.J., Fileman, T.W., and Portmann, J.E. 1988. Methods of analysis for hydrocarbons in marine samples. *Aquatic Environment Protection: Analytical Methods*. MAFF Directorate of Fisheries Research, Lowestoft, UK. (2). 25 pp.
- Law, R.J., and Klungsøyr, J. 1996. The 1994 QUASIMEME laboratory-performance studies: Polycyclic aromatic hydrocarbons (PAHs) in standard solutions. *Marine Pollution Bulletin*, 32: 667–673.
- Law, R.J., Klungsøyr, J., and Freriks, I.L. 1998. The QUASIMEME interlaboratory testing scheme for polycyclic aromatic hydrocarbons (PAHs): assessment of the first three rounds, 1994–1995. *Marine Pollution Bulletin*, 35: 64–77.
- Law, R.J., and Nicholson, M.D. 1995. Report on the results of the Intercomparison Programme on the Analysis of PAHs in Marine Media—Stage 1. ICES Cooperative Research Report, 207: 52–104.
- Malins, D.C., McCain, B.B., Landahl, J.T., Myers, M.S., Krahn, M.M., Brown, D.W., Chan, S.-L., and Roubal, W.T. 1988. Neoplastic and other diseases in fish in relation to toxic chemicals: an overview. *Aquatic Toxicology*, 11:43–67.
- Nondek, L., Kuziiek, M., and Krupicka, S. 1993. LC clean-up and GC-MS analysis of polycyclic aromatic hydrocarbons in river sediment. *Chromatographia*, 37: 381–391.
- Nyman, P.J., Perfetti, G.A., Joe, F.L. jr., and Diachenko, G.W. 1993. Comparison of two clean-up methodologies for the gas chromatographic-mass spectrometric detection of low nanogram per gram levels of polynuclear aromatic hydrocarbons in seafood. *Food Additives and Contaminants*, 10: 489–501.
- Perfetti, G.A., Nyman, P.J., Fisher, S., Joe, F.L. jr., and Diachenko, G.W. 1992. Determination of polynuclear aromatic hydrocarbons in seafood by liquid chromatography with fluorescence detection. *Journal of the Association of Official Analytical Chemists*, 75: 872–877.
- QUASIMEME. www.quasimeme.marlab.ac.uk
- Ramil Criado M. 2002. Optimization of microwave-assisted extraction method for the analysis of PCBs in ash samples. *Journal of Chromatography A*, 1: 1–9.
- Smedes, F. 1999. Determination of total lipid using non-chlorinated solvents. *The Analyst*, 124: 1711–1718.

- Vethaak, A.D., and Rheinallt, T. 1992. Fish disease as a monitor for marine pollution: the case of the North Sea. *Review of Fish Biology and Fisheries*, 2: 1-32.

Annex XVII:

OSPAR COMMISSION

**CEMP Guidelines for Monitoring Contaminants in Sediments
(OSPAR Agreement 2002-16)**

Technical Annex 3: Determination of parent and alkylated PAHs in biological materials



CEMP Guidelines for Monitoring Contaminants in Sediments

(OSPAR Agreement 2002-16)

Technical Annex 3: Determination of parent and alkylated PAHs in biological materials

1. Introduction

Polycyclic aromatic hydrocarbons (PAHs) consist of a variable number of fused benzene rings. By definition, PAHs contain at least two fused rings. PAHs arise from incomplete combustion processes and from both natural and anthropogenic sources, although the latter generally predominate. PAHs are also found in oil and oil products, and these include a wide range of alkylated PAHs formed as a result of diagenetic processes, whereas PAHs from combustion sources comprise mainly parent (non-alkylated) compounds. PAHs are of concern in the marine environment for two main reasons: firstly, low molecular weight (MW) PAHs can cause tainting of fish and shellfish and render them unfit for sale; secondly, metabolites of some of the high MW PAHs are potent animal and human carcinogens — benzo[*a*]pyrene is the prime example. Carcinogenic activity is closely related to structure. Benzo[*e*]pyrene and the four benzofluoranthene isomers all have a molecular weight of 252 Da; however, they are much less potent than benzo[*a*]pyrene. Less is known about toxicity of alkylated PAHs. However, one study has demonstrated that alkylated PAHs may have increased toxicity compared to the parent compound (Marvanova *et al.*, 2008).

PAHs are readily taken up by marine animals both across gill surfaces (lower MW PAHs) and from their diet. They may bioaccumulate, particularly in shellfish. Filter-feeding organisms such as bivalve molluscs can accumulate high concentrations of PAHs, both from chronic discharges to the sea (e.g., of sewage) and following oil spills. Fish are exposed to PAHs both via uptake across gill surfaces and from their diet, but do not generally accumulate high concentrations of PAHs as they possess an effective mixed-function oxygenase (MFO) system which allows them to metabolise PAHs and to excrete them in bile. Other marine vertebrate and marine mammals also metabolise PAHs efficiently. An assessment of the exposure of fish to PAHs therefore requires the determination of PAH metabolite concentrations in bile, as turnover times can be extremely rapid.

There are marked differences in the behaviour of PAHs in the aquatic environment between the low MW compounds (such as naphthalene; 128 Da) and the high MW compounds (such as benzo[*ghi*]perylene; 276 Da) as a consequence of their differing physico-chemical properties. The low MW compounds are appreciably water soluble (e.g. naphthalene) and can be bioaccumulated from the dissolved phase by transfer across gill surfaces, whereas the high MW compounds are relatively insoluble and hydrophobic, and can attach to both organic and inorganic particulates within the water column. PAHs derived from combustion sources may actually be deposited to the sea already

adsorbed to atmospheric particulates, such as soot particles. The sediment will act as a sink for PAHs in the marine environment.

2. Appropriate species for analysis of parent and alkylated PAHs

2.1 Benthic fish and shellfish

Guidance on the selection of appropriate species for contaminant monitoring is given in the OSPAR Joint Assessment and Monitoring Programme guidelines. All teleost fish have the capacity for rapid metabolism of PAHs, thereby limiting their usefulness for monitoring temporal or spatial trends of PAHs. Shellfish (particularly molluscs) generally have a lesser metabolic capacity towards PAHs, and so they are preferred because PAH concentrations are generally higher in their tissues. The blue mussel (*Mytilus edulis*) occurs in shallow waters along almost all coasts of the Northeast Atlantic. It is therefore suitable for monitoring in near shore waters. No distinction is made between *M. edulis* and *M. galloprovincialis* because the latter species, which may occur along Spanish and Portuguese coasts, fills a similar ecological niche. A sampling size range of 30–70 mm shell length is specified to ensure availability throughout the whole maritime area. In some areas (e.g., the Barents Sea), other species may be considered. Recent monitoring studies have indicated a seasonal cycle in PAH concentrations (particularly for combustion-derived PAHs) in mussels, with maximum concentrations in the winter prior to spawning and minimum concentrations in the summer. It is particularly important, therefore, that samples selected for trend monitoring and spatial comparisons are collected at the same time of year, and preferably in the first months of the year prior to spawning.

For the purposes of temporal trend monitoring, it is essential that long time-series with either a single species or a limited number of species be obtained. Care should be taken that the sample is representative of the population and that it can be sampled annually. There are advantages in the use of molluscs for this purpose as they are sessile, and so reflect the degree of contamination in the local area to a greater degree than fish which are mobile and metabolise PAHs relatively efficiently. The analysis of fish tissues is often undertaken in conjunction with biomarker and disease studies, and associations have been shown between the incidence of some diseases (e.g., liver neoplasia) in flatfish and the concentrations of PAHs in the sediments over which they live and feed (Malins *et al.*, 1988; Vethaak and Rheinallt, 1992). The exposure of fish to PAHs can be assessed by the analysis of PAH metabolites in bile, and by measuring the induction of mixed-function oxygenase enzymes which catalyse the formation of these metabolites.

3. Transportation

Live biota should be transported in closed containers at temperatures between 5°C and 10°C. For live animals it is important that the transport time is short and controlled (e.g., maximum of 24 hours). If biomarker determinations are to be made, then it will be necessary to store tissue samples at lower temperatures, for example, in liquid nitrogen at -196°C.

4. Pre-treatment and storage

4.1 Contamination

Sample contamination may occur during sampling, sample handling, pre-treatment, and analysis, due to the environment, the containers or packing materials used, the instruments used during sample preparation, and from the solvents and reagents used during the analytical procedures. Controlled

conditions are therefore required for all procedures. In the case of PAHs, particular care must be taken to avoid contamination at sea. On ships there are multiple sources of PAHs, such as the oils used for fuel and lubrication, and the exhaust from the ship's engines. It is important that the likely sources of contamination are identified and steps taken to preclude sample handling in areas where contamination can occur. A ship is a working vessel and there can always be procedures occurring as a result of the day-to-day operations (deck cleaning, automatic overboard bilge discharges, etc.) which could affect the sampling process. One way of minimizing the risk is to conduct dissection in a clean area, such as within a laminar-flow hood away from the deck areas of the vessel. It is also advisable to collect samples of the ship's fuel, bilge water, and oils and greases used on winches, etc., which can be used as fingerprinting samples at a later date, if there are suspicions of contamination in particular instances.

Freeze-drying of tissue samples may be a source of contamination due to the back-streaming of oil vapours from the rotary vacuum pumps. Furthermore, drying the samples may result in losses of the lower molecular weight and more volatile PAHs through evaporation (Law and Biscaya, 1994).

4.2 Shellfish

4.2.1 Depuration

Depending upon the situation, it may be desirable to depurate shellfish so as to void the gut contents and any associated contaminants before freezing or sample preparation. This is usually applied close to point sources, where the gut contents may contain significant quantities of PAHs associated with food and sediment particles which are not truly assimilated into the tissues of the mussels. Depuration should be undertaken in controlled conditions and in clean seawater; depuration over a period of 24 hours is usually sufficient. The aquarium should be aerated and the temperature and salinity of the water should be similar to that from which the animals were removed.

4.2.2 Dissection and storage

Mussels should be shucked live and opened with minimal tissue damage by detaching the adductor muscles from the interior of at least one valve. The soft tissues should be removed and homogenised as soon as possible, and frozen in glass jars or aluminium cans at -20°C until analysis. Plastic materials must not be used for sampling and storage owing to possible adsorption of the PAHs onto the container material. As PAHs are sensitive to photo-degradation, exposure to direct sunlight or other strong light must be avoided during storage of the samples as well as during all steps of sample preparation, including extraction and storage of the extracts (Law and Biscaya, 1994). The use of amber glassware is strongly recommended.

When samples are processed, both at sea and onshore, the dissection must be undertaken by trained personnel on a clean bench wearing clean gloves and using PAH-free stainless steel knives and scalpels. Stainless steel tweezers are recommended for holding tissues during dissection. After each sample has been prepared, all tools and equipment (such as homogenisers) should be cleaned by wiping with tissue and rinsing with solvent.

5. Analysis

5.1 Preparation of materials

Solvents and adsorptive materials must all be checked for the presence of PAHs and other interfering compounds. If found then the solvents, reagents, and adsorptive materials must be purified or cleaned using appropriate methods. Adsorptive materials should be cleaned by solvent extraction and/or by heating in a muffle oven as appropriate. Glass fibre materials (e.g. Soxhlet thimbles and filter papers used in pressurised liquid extraction (PLE)) should be cleaned by solvent extraction or pre-baked at 450°C overnight. It should be borne in mind that clean materials can be re-contaminated by exposure to laboratory air, particularly in urban locations, and so the method of storage after cleaning is of critical importance. Ideally, materials should be prepared immediately before use, but if they are to be stored, then the conditions should be considered critically. All containers which come into contact with the sample should be made of glass or aluminium, and should be pre-cleaned before use. Appropriate cleaning methods would include washing with detergents, rinsing with water of known quality, and finally solvent rinsing immediately before use.

5.2 Lipid determination

Although PAH data are not usually expressed on a lipid basis, the determination of the lipid content of tissues can be of use in characterising the samples. This will enable reporting concentrations on a wet weight or lipid weight basis. The lipid content should be determined on a separate subsample of the tissue homogenate, as some of the extraction techniques used routinely for PAHs determination (e.g., PLE with fat retainers, alkaline saponification) destroy or remove lipid materials. The total lipid content of fish or shellfish should be determined using the method of Bligh and Dyer (1959) as modified by Hanson and Olley (1963) or an equivalent method such as Smedes (1999). Extractable lipid may be used, particularly if the sample size is small and lipid content is high. It has been shown that if the lipid content is high (>5%) then extractable lipid will be comparable to the total lipid.

5.3 Extraction

PAHs are lipophilic and so are concentrated in the lipids of an organism, and a number of methods have been described for PAH extraction (Ehrhardt *et al.*, 1991). These methods generally utilise either Soxhlet extraction, or alkaline digestion followed by liquid-liquid extraction with an organic solvent. In the case of Soxhlet extraction, the wet tissue must be dried by mixing with a chemical drying agent (e.g., anhydrous sodium sulphate), in which case a time period of several hours is required between mixing and extraction in order to allow complete binding of the water in the sample. Samples are spiked with recovery standard and should be left overnight to equilibrate. Alkaline digestion is conducted on wet tissue samples, so this procedure is unnecessary.

Apolar solvents alone will not effectively extract all the PAHs from tissues when using Soxhlet extraction, and mixtures such as hexane/dichloromethane may be effective in place of solvents such as benzene and toluene, used historically for this purpose. Alkaline digestion has been extensively used in the determination of PAHs and hydrocarbons and is well documented. It is usually conducted in alcohol (methanol or ethanol), which should contain at least 10% water, and combines disruption of the cellular matrix, lipid extraction and saponification within a single procedure, thereby reducing sample handling and treatment. Solvents used for liquid-liquid extraction of the homogenate are usually apolar, such as pentane or hexane, and they will effectively extract all PAHs.

Alternatively extraction of wet or dry samples of biota may be carried out by pressurised liquid extraction (PLE). This is a more recent method, requiring less solvent and time for the extraction process. The wet biota sample is dried by mixing with sufficient anhydrous sodium sulphate to form a free flowing mixture and is packed into stainless steel extraction cells containing a glass fibre filter and sodium sulphate or glass powder to fill the cell. To ensure a better recovery samples may be extracted twice and extractions are performed at elevated temperatures and pressure.

5.4 Clean-up

Tissue extracts will always contain many compounds other than PAHs, and a suitable clean-up is necessary to remove those compounds which may interfere with the subsequent analysis. Different techniques may be used, either singly or in combination, and the choice will be influenced by the selectivity and sensitivity of the final measurement technique and also by the extraction method employed. If Soxhlet extraction was used, then there is a much greater quantity of residual lipid to be removed before the analytical determination can be made than in the case of alkaline digestion. An additional clean-up stage may therefore be necessary. The most commonly used clean-up methods involve the use of deactivated alumina or silica adsorption chromatography. When applying fractionation, the elution pattern has to be checked frequently. This should be carried out in the presence of sample matrix, as that can partially deactivate the clean-up column, resulting in earlier elution of the PAHs than in a standard solution.

Gel permeation chromatography (GPC) and high performance liquid chromatography (HPLC) based methods are also employed (Nondek *et al.*, 1993; Nyman *et al.*, 1993; Perfetti *et al.*, 1992). The major advantages of using HPLC-based clean-up methods are their ease of automation and reproducibility.

Isocratic HPLC fractionation of the extract can be used to give separate aliphatic and aromatic fractions (Webster *et al.*, 2002). A metal-free silica column is used for the clean-up/fractionation as dibenzothiophene (DBT) can be retained on ordinary silica columns. The split time is determined by injection of a solution containing representative aliphatic and PAH standards. The silica column is regenerated by a cleaning cycle after a set number of samples. If PAHs are to be analysed by HPLC and there are significant amounts of alkylated PAHs present then the removal of the alkylated PAHs may be difficult.

5.5 Pre-concentration

In the methods suggested above, all result in an extract in which non-polar solvents are dominant. The sample volume should be 2 ml or greater to avoid errors when transferring solvents during the clean-up stages. Syncore parallel evaporators can be used with careful optimisation of the evaporation parameters. Evaporation of solvents using a rotary-film evaporator should be performed at low temperature (water bath temperature of 30°C or lower) and under controlled pressure conditions, in order to prevent losses of the more volatile PAHs such as naphthalenes. For the same reasons, evaporation to dryness must be avoided. When reducing the sample to final volume, solvents can be removed by a stream of clean nitrogen gas. Suitable solvents for injection into the GC-MS include pentane, hexane, heptane, *iso*-hexane and *iso*-octane.

5.6 Selection of PAHs to be determined

The choice of PAHs to be analysed is not straightforward, both because of differences in the range of PAH compounds resulting from combustion processes and from oil and oil products, and also because the aims of specific monitoring programmes can require the analysis of different representative

groups of compounds. PAHs arising from combustion processes are predominantly parent (unsubstituted) compounds, whereas oil and its products contain a much wider range of alkylated compounds in addition to the parent PAHs. This has implications for the analytical determination, as both HPLC-based and GC-based techniques are adequate for the determination of a limited range of parent PAHs in samples influenced by combustion processes, whereas in areas of significant oil contamination and following oil spills only GC-MS has sufficient selectivity to determine the full range of PAHs present. The availability of pure individual PAHs for the preparation of standards is problematic and limits both the choice of determinands and, to some degree, the quantification procedures which can be used. The availability of reference materials certified for PAHs is also rather limited. A list of target parent and alkylated PAHs suitable for environmental monitoring is given in Table A1.1. This differs both from the list previously developed within ICES specifically for intercomparison purposes, and the historic list of Borneff. In both cases, the lists were concentrated on a subset of parent (predominantly combustion-derived) PAHs due to analytical limitations. This approach completely neglects the determination of alkylated PAHs, which allows the interpretation of PAH accumulation from multiple sources including those due to oil inputs. It will not be necessary for all of these PAH compounds and groups to be analysed in all cases, but an appropriate selection can be made from this list depending on the specific aims of the monitoring programme to be undertaken.

Table A1.1: Compounds of interest for environmental monitoring for which the guidelines apply. For compounds in italics standards are not available for any isomers in this group.

Compound	MW	Compound	MW
Naphthalene	128	2, 3d-benzonaphthothiophene	234
C ₁ -Naphthalenes	142	C ₁ -234	248
C ₂ -Naphthalenes	156	C ₂ -Fluoranthenes/Pyrenes	230
C ₃ -Naphthalenes	170	Benz[<i>a</i>]anthracene	228
<i>C₄-Naphthalenes</i>	184	Chrysene	228
Acenaphthylene	152	2,3-Benzanthracene	228
Acenaphthene	154	C ₁ - Benz[<i>a</i>]anthracene/ Chrysene	242
Biphenyl	154	C ₂ - Benz[<i>a</i>]anthracene/ Chrysene	256
Fluorene	166	C ₃ - Benz[<i>a</i>]anthracene/ Chrysene	270
C ₁ -Fluorenes	180	Benzo[<i>a</i>]fluoranthene	252
<i>C₂-Fluorenes</i>	194	Benzo[<i>b</i>]fluoranthene	252
<i>C₃-Fluorenes</i>	208	Benzo[<i>j</i>]fluoranthene	252
Dibenzothiophene	184	Benzo[<i>k</i>]fluoranthene	252
C ₁ -Dibenzothiophenes	198	Benzo[<i>e</i>]pyrene	252
<i>C₂-Dibenzothiophenes</i>	212	Benzo[<i>a</i>]pyrene	252
<i>C₃-Dibenzothiophenes</i>	226	Perylene	252
Phenanthrene	178	Indeno[1,2,3- <i>cd</i>]pyrene	276
Anthracene	178	Benzo[<i>ghi</i>]perylene	276
C ₁ -Phenanthrenes/Anthracenes	192	Dibenz[<i>a,h</i>]anthracene	278
C ₂ -Phenanthrenes/Anthracenes	206	Benzo[<i>k</i>]fluoranthene	252
C ₃ -Phenanthrenes/Anthracenes	220	Cyclopenta[<i>cd</i>]pyrene	226
Fluoranthene	202	Naphtho[2,1- <i>a</i>]pyrene	302
Pyrene	202	Dibenz[<i>a,e</i>]pyrene	302

C ₁ -Fluoranthenes/Pyrenes	216	Dibenz[<i>a,i</i>]pyrene	302
2, 1d-benzonaphthothiophene	234	Dibenz[<i>a,l</i>]pyrene	302
1,2d-benzonaphthothiophene	234	Dibenz[<i>a,h</i>]pyrene	302

5.7 Instrumental determination of PAHs

The greatest sensitivity and selectivity in routine analysis for parent PAH is achieved by combining HPLC with fluorescence detection (HPLC-UVF) or capillary gas chromatography with mass spectrometry (GC-MS). However, for the analysis of parent and alkylated PAHs GC-MS is the method of choice. In terms of flexibility, GC-MS is the most capable technique, as in principle it does not limit the selection of determinands in any way, while HPLC is suited only to the analysis of parent PAHs. In the past, analyses have also been conducted using HPLC with UV-absorption detection and GC with flame-ionisation detection, but neither can be recommended for alkylated PAHs because of their relatively poor selectivity. Both in terms of the initial capital cost of the instrumentation, and the cost per sample analysed, HPLC-UVF is cheaper than GC-MS. With the advent of high-sensitivity benchtop GC-MS systems, however, this cost advantage is now not as marked as in the past, and the additional information regarding sources available makes GC-MS the method of choice.

Limits of determination within the range of 0.05 to 0.5 µg kg⁻¹ wet weight for individual PAH compounds should be achievable by GC-MS. However this limit can be lowered in routine analysis.

5.7.1 GC-MS

The three injection modes commonly used are splitless, on-column and PTV (programmed temperature vaporiser). Automatic sample injection should be used wherever possible to improve the reproducibility of injection and the precision of the overall method. If splitless injection is used, the liner should be of sufficient capacity to contain the injected solvent volume after evaporation. For PAH analysis, the cleanliness of the liner is also very important if adsorption effects and discrimination are to be avoided, and the analytical column should not contain active sites to which PAHs can be adsorbed. Helium is the preferred carrier gas, and only capillary columns should be used. Because of the wide boiling range of the PAHs to be determined and the surface-active properties of the higher PAHs, the preferred column length is 25–50 m, with an internal diameter of 0.15 mm to 0.3 mm. Film thicknesses of 0.2 µm to 1 µm are generally used; this choice has little impact on critical resolution, but thicker films are often used when one-ring aromatic compounds are to be determined alongside PAHs, or where a high sample loading is needed. No stationary phase has been found on which all PAH isomers can be resolved; the most commonly used stationary phase for PAH analysis is 5% phenyl methylsilicone (DB-5 or equivalent). This will not, however, resolve critical isomers such as benzo[*b*], [*l*] and [*k*]fluoranthenes, or chrysene from triphenylene. Chrysene and triphenylene can be separated on other columns, if necessary such as a 60 m non polar column such as DB5MS. For PAHs there is no sensitivity gain from the use of chemical ionisation (either positive or negative ion), so analyses are usually conducted in electron-impact mode at 70eV. Quadrupole instruments are used in single ion monitoring to achieve greater sensitivity. The masses to be detected are programmed to change during the analysis as different PAHs elute from the capillary column. In SIM the molecular ion is used for quantification. Qualifier ions can be used to confirm identification but they are limited for PAHs. Triple quadrupole mass spectrometry can also be used and will give greater sensitivity. Some instruments such as ion-trap and time of flight mass spectrometers exhibit the same sensitivity in both modes, so full scan spectra can be used for quantification.

An example of mass spectrometer operating conditions in SIM mode is given in Table A1.2. The ions are grouped and screened within GC time windows of the compounds. In general the number of ions should not be greater than 20. The dwell time is important parameter and should be close for each ion. For GC capillary column analysis a dwell time should not be shorter than 20 ms, while a sum of a dwell in each retention time windows should not be greater than 500 ms. An example of conditions that can be used along with dwell times are shown in Table A1.2.

Table A.1.2: Example of operational conditions for the GC-MS analysis of parent and alkylated PAHs.

Group N°	Retention time (min)	Dwell time (ms)	Ions in group (AMU)					
			128	136	142	170	182	184
1	8.00	100	128	136	142			
2	21.00	100	152	156	160			
3	23.70	100	154	164	168	170		
4	26.80	80	166	176	180	182	184	
5	31.60	80	178	184	188	194	196	198
6	35.30	100	192	198				
7	36.60	100	206	212				
8	39.40	80	202	206	212	216	220	226
9	44.65	100	216	220				
10	45.30	100	226	228	230	234	240	
11	48.58	90	242	248				
12	52.00	100	252	256	264	266		
13	59.00	100	266	276	278	288		

Alkylated homologues of PAHs (C1–C4), mainly associated with petrogenic sources, contain a number of different isomers that can give very complex but distinct distribution profiles when analysed by GC-MS. Integration of each isomer separately is difficult for most alkylated PAHs. 1- and 2-Methyl naphthalene give well resolved peaks that can be quantified separately. C1-Phenanthrene/anthracene gives five distinct peaks corresponding to 3-methyl phenanthrene, 2-methyl phenanthrene, 2-methyl anthracene, 4- and 9-methyl phenanthrene and 1-methyl phenanthrene. These may be integrated as a group or as separate isomers. For all other alkylated PAHs the area for all isomers may be summed and quantified against a single representative isomer. This method will lead, however, to an overestimation of the concentration as may include non-alkylated PAHs. Examples of integrations of both parent and alkylated PAHs are shown in Appendix 1.

6. Calibration and quantification

6.1 Standards

The availability of pure PAH compounds are limited. Although most of the parent compounds can be purchased as pure compounds, the range of possible alkyl-substituted PAHs is vast and only a limited selection of them can be obtained. PAH standards are available for at least one isomer of most alkyl group listed in Table A1.1. A range of deuterated PAHs (normally 5 to 7) should be used as internal standards to cover the range of PAHs being analysed in samples. A range of fully-deuterated parent PAHs is available for use as standards in PAH analysis. Suitable standards could range from d_8 -naphthalene to d_{14} -dibenz[*a,h*]anthracene. Crystalline PAHs of known purity should be used for the preparation of calibration standards. If the quality of the standard materials is not guaranteed by the producer or supplier (as for certified reference materials), then it should be checked by GC-MS analysis. Solid standards should be weighed to a precision of 10^{-5} grams. Calibration standards should

be stored in the dark because some PAHs are photosensitive, and ideally solutions to be stored should be sealed in amber glass ampoules or sealed GC vials. Otherwise, they can be stored in a refrigerator in stoppered measuring cylinders or flasks that are gas tight to avoid evaporation of the solvent during storage.

6.2 Calibration

Multilevel calibration with at least five calibration levels is preferred to adequately define the calibration curve. In general, GC-MS calibration is linear over a considerable concentration range but may exhibit a change of slope at very low concentrations. Quantification should be conducted in the linear region of the calibration curve. A separate calibration curve may be used where sample concentrations are very low. An internal standard method should be employed, using a range of deuterated PAHs as internal standards.

6.3 Recovery

The recovery of analytes should be checked and reported. Given the wide boiling range of the PAHs to be determined, the recovery may vary with compound group, from the volatile PAHs of low molecular weight to the larger compounds. Deuterated standards can be added in two groups: those to be used for quantification are added at the start of the analytical procedure, whilst those from which the absolute recovery will be assessed are added prior to GC-MS injection. This allows the recovery to be calculated.

7. Analytical Quality Control

Planners of monitoring programmes must decide on the accuracy, precision, repeatability, and limits of detection and determination which they consider acceptable. Achievable limits of determination for each individual component are as follows:

- for GC-MS measurements: $0.05 \mu\text{g kg}^{-1} \text{ ww}$;
- Further information on analytical quality control procedures for PAHs can be found elsewhere (Law and de Boer, 1995). A procedural blank should be measured with each sample batch, and should be prepared simultaneously using the same chemical reagents and solvents as for the samples. Its purpose is to indicate sample contamination by interfering compounds, which will result in errors in quantification. The procedural blank is also very important in the calculation of limits of detection and limits of quantification for the analytical method. In addition, a laboratory reference material (LRM) should be analysed within each sample batch. The LRM must be homogeneous and well-characterised for the determinands of interest within the analytical laboratory. Ideally, stability tests should have been undertaken to show that the LRM yields consistent results over time. The LRM should be of the same matrix type (e.g. mussels) as the samples, and the determinand concentrations should be in the same range as those in the samples. Realistically, and given the wide range of PAH concentrations encountered, particularly in oil spill investigations, this is bound to involve some compromise. The data produced for the LRM in successive sample batches should be used to prepare control charts. It is also useful to analyse the LRM in duplicate from time to time to check within-batch analytical variability. The analysis of an LRM is primarily intended as a check that the analytical method is under control and yields acceptable precision, but a certified reference material (CRM) of a similar matrix should be analysed periodically in order to check the method bias. The availability of biota CRMs certified for PAHs is very limited, and in all cases the number of PAHs for which certified values are

provided is small. At present, only NIST 1974a (a frozen wet mussel tissue) and NIST 2974 (a freeze-dried mussel tissue) are available. At regular intervals, the laboratory should participate in an intercomparison or proficiency exercise in which samples are circulated without knowledge of the determinand concentrations, in order to provide an independent check on performance.

8. Data reporting

The calculation of results and the reporting of data can represent major sources of error, as has been shown in intercomparison studies for PAHs. Control procedures should be established in order to ensure that data are correct and to obviate transcription errors. Data stored on databases should be checked and validated, and checks are also necessary when data are transferred between databases. Data should be reported in accordance with the latest ICES reporting formats.

9. References

Bligh, E. G., and Dyer, W. J. 1959. A rapid method of total lipid extraction and purification. *Canadian Journal of Biochemistry and Physiology*. 37: 911–917.

Ehrhardt, M., Klungsøyr, J., and Law, R. J. 1991. Hydrocarbons: Review of methods for analysis in sea water, biota, and sediments. *Techniques in Marine Environmental Sciences*. 12: 19–22.

Farrington, J. W., Davis, A. C., Livramento, J. B., Clifford, C. H., Frew, N. M., and Knap, A. 1986. ICES/IOC Intercomparison Exercises on the Determination of Petroleum Hydrocarbons in Biological Tissues (mussel homogenate) – ICES (2/HC/BT). ICES Cooperative Research Report, 141: 1–75.

Hanson, S. W. F., and Olley, J. 1963. Application of the Bligh and Dyer method of lipid extraction to tissue homogenates. *Biochem. J.*, 89: 101–102.

Law, R. J., and Biscaya, J. L. 1994. Polycyclic aromatic hydrocarbons (PAHs)—Problems and progress in sampling, analysis and interpretation. *Marine Pollution Bulletin*, 29: 235–241.

Law, R. J., and de Boer, J. 1995. Quality assurance of analysis of organic compounds in marine matrices: Application to analysis of chlorobiphenyls and polycyclic aromatic hydrocarbons. *In Quality Assurance in Environmental Monitoring—Sampling and Sample Pretreatment*. 129–156. Ed. by P. Quevauviller. VCH Publishers, Weinheim, Germany.

Law, R. J., Fileman, T. W., and Portmann, J. E. 1988. Methods of analysis for hydrocarbons in marine samples. *Aquatic Environment Protection: Analytical Methods*. MAFF Directorate of Fisheries Research, Lowestoft, UK. (2). 25.

Law, R. J., and Klungsøyr, J. 1996. The 1994 QUASIMEME laboratory-performance studies: Polycyclic aromatic hydrocarbons (PAHs) in standard solutions. *Marine Pollution Bulletin*, 32: 667–673.

Law, R. J., Klungsøyr, J., and Fredriks, I. L. 1998. The QUASIMEME interlaboratory testing scheme for polycyclic aromatic hydrocarbons (PAHs): assessment of the first three rounds, 1994–1995. *Marine Pollution Bulletin*. 35: 64–77.

Law, R. J., and Nicholson, M. D. 1995. Report on the results of the Intercomparison Programme on the Analysis of PAHs in Marine Media—Stage 1. ICES Cooperative Research Report. 207: 52–104.

Malins, D. C., McCain, B. B., Landahl, J. T., Myers, M. S., Krahn, M. M., Brown, D. W., Chan, S-L., and Roubal, W. T. 1988. Neoplastic and other diseases in fish in relation to toxic chemicals: an overview. *Aquatic Toxicology*. 11: 43–67.

Marvanova, S., Vondracek, J., Pencikova, K., Trilecova, L., Krcmar, P., Topinka, J., Novakova, Z., Milcova, A., and Machala, M. 2008. Toxic effects of methylated[a]anthracenes in liver cells. *Chemical Research in Toxicology*. In press.

Nondek, L., Kuzilek, M., and Krupicka, S. 1993. LC clean-up and GC-MS analysis of polycyclic aromatic hydrocarbons in river sediment. *Chromatographia*. 37: 381–391.

Nyman, P. J., Perfetti, G. A., Joe, F. L. jr., and Diachenko, G. W. 1993. Comparison of two clean-up methodologies for the gas chromatographic-mass spectrometric detection of low nanogram per gram levels of polynuclear aromatic hydrocarbons in seafood. *Food Additives and Contaminants*. 10: 489–501.

Perfetti, G. A., Nyman, P. J., Fisher, S., Joe, F. L. jr., and Diachenko, G. W. 1992. Determination of polynuclear aromatic hydrocarbons in seafood by liquid chromatography with fluorescence detection. *Journal of the Association of Official Analytical Chemists*. 75: 872–877.

Revision of the Nordtest Methodology for oil spill identification, <http://www.nordicinnovation.net/nordtestfiler/tec499.pdf>

Smedes, F. 1999. Determination of total lipid using non-chlorinated solvents. *Analyst*, 124: 1711-1718.

Vethaak, A. D., and Rheinallt, T. 1992. Fish disease as a monitor for marine pollution: the case of the North Sea. *Review of Fish Biology and Fisheries*. 2: 1–32.

Webster, L., McIntosh, A. D., Megginson, C., Shepherd, N. J., and Moffat, C. F. 2002. The polycyclic aromatic hydrocarbon composition of mussels (*Mytilus edulis*) from Scottish coastal waters. *Journal of Environmental Monitoring*. 5:150-159.

Annex XVIII:

Method 1613

**Tetra- through Octa-Chlorinated Dioxins and Furans by Isotope
Dilution HRGC/HRMS**

Method 1613

**Tetra- through Octa-Chlorinated Dioxins and Furans by Isotope
Dilution HRGC/HRMS**

October 1994

**U.S. Environmental Protection Agency
Office of Water
Engineering and Analysis Division (4303)
401 M Street S.W.
Washington, D.C. 20460**

Acknowledgments

This method was prepared under the direction of William A. Telliard of the Engineering and Analysis Division within the EPA Office of Water. This document was prepared under EPA Contract No. 68-C3-0337 by DynCorp Environmental Services Division with assistance from its subcontractor Interface, Inc.

Disclaimer

This method has been reviewed by the Engineering and Analysis Division, U.S. Environmental Protection Agency, and approved for publication. Mention of trade names or commercial products does not constitute endorsement or recommendation for use.

Introduction

Method 1613 was developed by the United States Environmental Protection Agency's Office of Science and Technology for isomer-specific determination of the 2,3,7,8-substituted, tetra-through octa-chlorinated, dibenzo-*p*-dioxins and dibenzofurans in aqueous, solid, and tissue matrices by isotope dilution, high resolution capillary column gas chromatography (HRGC)/high resolution mass spectrometry (HRMS).

Questions concerning this method or its application should be addressed to:

W.A. Telliard
US EPA Office of Water
Analytical Methods Staff
Mail Code 4303
401 M Street, SW
Washington, D.C. 20460
202/260-7120

Requests for additional copies should be directed to:

Water Resource Center
Mail Code RC-4100
401 M Street, SW
Washington, D.C. 20460
202/260-7786 or 202/260-2814

Method 1613, Revision B

Tetra- through Octa-Chlorinated Dioxins and Furans by Isotope Dilution HRGC/HRMS

1.0 Scope and Application

- 1.1 This method is for determination of tetra- through octa-chlorinated dibenzo-*p*-dioxins (CDDs) and dibenzofurans (CDFs) in water, soil, sediment, sludge, tissue, and other sample matrices by high resolution gas chromatography/high resolution mass spectrometry (HRGC/HRMS). The method is for use in EPA's data gathering and monitoring programs associated with the Clean Water Act, the Resource Conservation and Recovery Act, the Comprehensive Environmental Response, Compensation and Liability Act, and the Safe Drinking Water Act. The method is based on a compilation of EPA, industry, commercial laboratory, and academic methods (References 1-6).
- 1.2 The seventeen 2,3,7,8-substituted CDDs/CDFs listed in Table 1 may be determined by this method. Specifications are also provided for separate determination of 2,3,7,8-tetrachloro-dibenzo-*p*-dioxin (2,3,7,8-TCDD) and 2,3,7,8-tetrachloro-dibenzofuran (2,3,7,8-TCDF).
- 1.3 The detection limits and quantitation levels in this method are usually dependent on the level of interferences rather than instrumental limitations. The minimum levels (MLs) in Table 2 are the levels at which the CDDs/CDFs can be determined with no interferences present. The Method Detection Limit (MDL) for 2,3,7,8-TCDD has been determined as 4.4 pg/L (parts-per-quadrillion) using this method.
- 1.4 The GC/MS portions of this method are for use only by analysts experienced with HRGC/HRMS or under the close supervision of such qualified persons. Each laboratory that uses this method must demonstrate the ability to generate acceptable results using the procedure in Section 9.2.
- 1.5 This method is "performance-based". The analyst is permitted to modify the method to overcome interferences or lower the cost of measurements, provided that all performance criteria in this method are met. The requirements for establishing method equivalency are given in Section 9.1.2.
- 1.6 Any modification of this method, beyond those expressly permitted, shall be considered a major modification subject to application and approval of alternate test procedures under 40 CFR 136.4 and 136.5.

2.0 Summary of Method

Flow charts that summarize procedures for sample preparation, extraction, and analysis are given in Figure 1 for aqueous and solid samples, Figure 2 for multi-phase samples, and Figure 3 for tissue samples.

2.1 Extraction

- 2.1.1 Aqueous samples (samples containing less than 1% solids)—Stable isotopically labeled analogs of 15 of the 2,3,7,8-substituted CDDs/CDFs are spiked into a 1 L sample, and the sample is extracted by one of three procedures:
- 2.1.1.1 Samples containing no visible particles are extracted with methylene chloride in a separatory funnel or by the solid-phase extraction technique summarized in Section 2.1.1.3. The extract is concentrated for cleanup.
- 2.1.1.2 Samples containing visible particles are vacuum filtered through a glass-fiber filter. The filter is extracted in a Soxhlet/Dean-Stark (SDS) extractor (Reference 7), and the filtrate is extracted with methylene chloride in a separatory funnel. The methylene chloride extract is concentrated and combined with the SDS extract prior to cleanup.
- 2.1.1.3 The sample is vacuum filtered through a glass-fiber filter on top of a solid-phase extraction (SPE) disk. The filter and disk are extracted in an SDS extractor, and the extract is concentrated for cleanup.
- 2.1.2 Solid, semi-solid, and multi-phase samples (but not tissue)—The labeled compounds are spiked into a sample containing 10 g (dry weight) of solids. Samples containing multiple phases are pressure filtered and any aqueous liquid is discarded. Coarse solids are ground or homogenized. Any non-aqueous liquid from multi-phase samples is combined with the solids and extracted in an SDS extractor. The extract is concentrated for cleanup.
- 2.1.3 Fish and other tissue—The sample is extracted by one of two procedures:
- 2.1.3.1 Soxhlet or SDS extraction—A 20 g aliquot of sample is homogenized, and a 10 g aliquot is spiked with the labeled compounds. The sample is mixed with sodium sulfate, allowed to dry for 12-24 hours, and extracted for 18-24 hours using methylene chloride:hexane (1:1) in a Soxhlet extractor. The extract is evaporated to dryness, and the lipid content is determined.
- 2.1.3.2 HCl digestion—A 20 g aliquot is homogenized, and a 10 g aliquot is placed in a bottle and spiked with the labeled compounds. After equilibration, 200 mL of hydrochloric acid and 200 mL of methylene chloride:hexane (1:1) are added, and the bottle is agitated for 12-24 hours. The extract is evaporated to dryness, and the lipid content is determined.
- 2.2 After extraction, $^{37}\text{Cl}_4$ -labeled 2,3,7,8-TCDD is added to each extract to measure the efficiency of the cleanup process. Sample cleanups may include back-extraction with acid and/or base, and gel permeation, alumina, silica gel, Florisil and activated carbon chromatography. High-performance liquid chromatography (HPLC) can be used for further isolation of the 2,3,7,8-isomers or other specific isomers or congeners. Prior to the cleanup procedures cited above, tissue extracts are cleaned up using an anthropogenic isolation column, a batch silica gel adsorption, or sulfuric acid and base back-extraction, depending on the tissue extraction procedure used.

- 2.3 After cleanup, the extract is concentrated to near dryness. Immediately prior to injection, internal standards are added to each extract, and an aliquot of the extract is injected into the gas chromatograph. The analytes are separated by the GC and detected by a high-resolution ($\geq 10,000$) mass spectrometer. Two exact m/z 's are monitored for each analyte.
- 2.4 An individual CDD/CDF is identified by comparing the GC retention time and ion-abundance ratio of two exact m/z 's with the corresponding retention time of an authentic standard and the theoretical or acquired ion-abundance ratio of the two exact m/z 's. The non-2,3,7,8 substituted isomers and congeners are identified when retention times and ion-abundance ratios agree within predefined limits. Isomer specificity for 2,3,7,8-TCDD and 2,3,7,8-TCDF is achieved using GC columns that resolve these isomers from the other tetra-isomers.
- 2.5 Quantitative analysis is performed using selected ion current profile (SICP) areas, in one of three ways:
- 2.5.1 For the 15 2,3,7,8-substituted CDDs/CDFs with labeled analogs (see Table 1), the GC/MS system is calibrated, and the concentration of each compound is determined using the isotope dilution technique.
- 2.5.2 For 1,2,3,7,8,9-HxCDD, OCDF, and the labeled compounds, the GC/MS system is calibrated and the concentration of each compound is determined using the internal standard technique.
- 2.5.3 For non-2,3,7,8-substituted isomers and for all isomers at a given level of chlorination (i.e., total TCDD), concentrations are determined using response factors from calibration of the CDDs/CDFs at the same level of chlorination.
- 2.6 The quality of the analysis is assured through reproducible calibration and testing of the extraction, cleanup, and GC/MS systems.

3.0 Definitions

Definitions are given in the glossary at the end of this method.

4.0 Contamination and Interferences

- 4.1 Solvents, reagents, glassware, and other sample processing hardware may yield artifacts and/or elevated baselines causing misinterpretation of chromatograms (References 8-9). Specific selection of reagents and purification of solvents by distillation in all-glass systems may be required. Where possible, reagents are cleaned by extraction or solvent rinse.
- 4.2 Proper cleaning of glassware is extremely important, because glassware may not only contaminate the samples but may also remove the analytes of interest by adsorption on the glass surface.
- 4.2.1 Glassware should be rinsed with solvent and washed with a detergent solution as soon after use as is practical. Sonication of glassware containing a detergent solution for approximately 30 seconds may aid in cleaning. Glassware with

- removable parts, particularly separatory funnels with fluoropolymer stopcocks, must be disassembled prior to detergent washing.
- 4.2.2 After detergent washing, glassware should be rinsed immediately, first with methanol, then with hot tap water. The tap water rinse is followed by another methanol rinse, then acetone, and then methylene chloride.
- 4.2.3 Do not bake reusable glassware in an oven as a routine part of cleaning. Baking may be warranted after particularly dirty samples are encountered but should be minimized, as repeated baking of glassware may cause active sites on the glass surface that will irreversibly adsorb CDDs/CDFs.
- 4.2.4 Immediately prior to use, the Soxhlet apparatus should be pre-extracted with toluene for approximately three hours (see Sections 12.3.1 through 12.3.3). Separatory funnels should be shaken with methylene chloride/toluene (80/20 mixture) for two minutes, drained, and then shaken with pure methylene chloride for two minutes.
- 4.3 All materials used in the analysis shall be demonstrated to be free from interferences by running reference matrix method blanks initially and with each sample batch (samples started through the extraction process on a given 12-hour shift, to a maximum of 20 samples).
- 4.3.1 The reference matrix must simulate, as closely as possible, the sample matrix under test. Ideally, the reference matrix should not contain the CDDs/CDFs in detectable amounts, but should contain potential interferences in the concentrations expected to be found in the samples to be analyzed. For example, a reference sample of human adipose tissue containing pentachloronaphthalene can be used to exercise the cleanup systems when samples containing pentachloronaphthalene are expected.
- 4.3.2 When a reference matrix that simulates the sample matrix under test is not available, reagent water (Section 7.6.1) can be used to simulate water samples; playground sand (Section 7.6.2) or white quartz sand (Section 7.3.2) can be used to simulate soils; filter paper (Section 7.6.3) can be used to simulate papers and similar materials; and corn oil (Section 7.6.4) can be used to simulate tissues.
- 4.4 Interferences coextracted from samples will vary considerably from source to source, depending on the diversity of the site being sampled. Interfering compounds may be present at concentrations several orders of magnitude higher than the CDDs/CDFs. The most frequently encountered interferences are chlorinated biphenyls, methoxy biphenyls, hydroxydiphenyl ethers, benzylphenyl ethers, polynuclear aromatics, and pesticides. Because very low levels of CDDs/CDFs are measured by this method, the elimination of interferences is essential. The cleanup steps given in Section 13 can be used to reduce or eliminate these interferences and thereby permit reliable determination of the CDDs/CDFs at the levels shown in Table 2.
- 4.5 Each piece of reusable glassware should be numbered to associate that glassware with the processing of a particular sample. This will assist the laboratory in tracking possible sources of contamination for individual samples, identifying glassware associated with

highly contaminated samples that may require extra cleaning, and determining when glassware should be discarded.

- 4.6 Cleanup of tissue—The natural lipid content of tissue can interfere in the analysis of tissue samples for the CDDs/CDFs. The lipid contents of different species and portions of tissue can vary widely. Lipids are soluble to varying degrees in various organic solvents and may be present in sufficient quantity to overwhelm the column chromatographic cleanup procedures used for cleanup of sample extracts. Lipids must be removed by the lipid removal procedures in Section 13.7, followed by alumina (Section 13.4) or Florisil (Section 13.8), and carbon (Section 13.5) as minimum additional cleanup steps. If chlorodiphenyl ethers are detected, as indicated by the presence of peaks at the exact m/z 's monitored for these interferents, alumina and/or Florisil cleanup must be employed to eliminate these interferences.

5.0 Safety

- 5.1 The toxicity or carcinogenicity of each compound or reagent used in this method has not been precisely determined; however, each chemical compound should be treated as a potential health hazard. Exposure to these compounds should be reduced to the lowest possible level.
- 5.1.1 The 2,3,7,8-TCDD isomer has been found to be acnegenic, carcinogenic, and teratogenic in laboratory animal studies. It is soluble in water to approximately 200 ppt and in organic solvents to 0.14%. On the basis of the available toxicological and physical properties of 2,3,7,8-TCDD, all of the CDDs/CDFs should be handled only by highly trained personnel thoroughly familiar with handling and cautionary procedures and the associated risks.
- 5.1.2 It is recommended that the laboratory purchase dilute standard solutions of the analytes in this method. However, if primary solutions are prepared, they shall be prepared in a hood, and a NIOSH/MESA approved toxic gas respirator shall be worn when high concentrations are handled.
- 5.2 The laboratory is responsible for maintaining a current awareness file of OSHA regulations regarding the safe handling of the chemicals specified in this method. A reference file of material safety data sheets (MSDSs) should also be made available to all personnel involved in these analyses. It is also suggested that the laboratory perform personal hygiene monitoring of each analyst who uses this method and that the results of this monitoring be made available to the analyst. Additional information on laboratory safety can be found in References 10-13. The references and bibliography at the end of Reference 13 are particularly comprehensive in dealing with the general subject of laboratory safety.
- 5.3 The CDDs/CDFs and samples suspected to contain these compounds are handled using essentially the same techniques employed in handling radioactive or infectious materials. Well-ventilated, controlled access laboratories are required. Assistance in evaluating the health hazards of particular laboratory conditions may be obtained from certain consulting laboratories and from State Departments of Health or Labor, many of which have an industrial health service. The CDDs/CDFs are extremely toxic to laboratory animals. Each laboratory must develop a strict safety program for handling these compounds. The practices in References 2 and 14 are highly recommended.

- 5.3.1 Facility—When finely divided samples (dusts, soils, dry chemicals) are handled, all operations (including removal of samples from sample containers, weighing, transferring, and mixing) should be performed in a glove box demonstrated to be leak tight or in a fume hood demonstrated to have adequate air flow. Gross losses to the laboratory ventilation system must not be allowed. Handling of the dilute solutions normally used in analytical and animal work presents no inhalation hazards except in the case of an accident.
- 5.3.2 Protective equipment—Disposable plastic gloves, apron or lab coat, safety glasses or mask, and a glove box or fume hood adequate for radioactive work should be used. During analytical operations that may give rise to aerosols or dusts, personnel should wear respirators equipped with activated carbon filters. Eye protection equipment (preferably full face shields) must be worn while working with exposed samples or pure analytical standards. Latex gloves are commonly used to reduce exposure of the hands. When handling samples suspected or known to contain high concentrations of the CDDs/CDFs, an additional set of gloves can also be worn beneath the latex gloves.
- 5.3.3 Training—Workers must be trained in the proper method of removing contaminated gloves and clothing without contacting the exterior surfaces.
- 5.3.4 Personal hygiene—Hands and forearms should be washed thoroughly after each manipulation and before breaks (coffee, lunch, and shift).
- 5.3.5 Confinement—Isolated work areas posted with signs, segregated glassware and tools, and plastic absorbent paper on bench tops will aid in confining contamination.
- 5.3.6 Effluent vapors—The effluents of sample splitters from the gas chromatograph (GC) and from roughing pumps on the mass spectrometer (MS) should pass through either a column of activated charcoal or be bubbled through a trap containing oil or high-boiling alcohols to condense CDD/CDF vapors.
- 5.3.7 Waste Handling—Good technique includes minimizing contaminated waste. Plastic bag liners should be used in waste cans. Janitors and other personnel must be trained in the safe handling of waste.
- 5.3.8 Decontamination
- 5.3.8.1 Decontamination of personnel—Use any mild soap with plenty of scrubbing action.
- 5.3.8.2 Glassware, tools, and surfaces—Chlorothene NU Solvent is the least toxic solvent shown to be effective. Satisfactory cleaning may be accomplished by rinsing with Chlorothene, then washing with any detergent and water. If glassware is first rinsed with solvent, then the dish water may be disposed of in the sewer. Given the cost of disposal, it is prudent to minimize solvent wastes.
- 5.3.9 Laundry—Clothing known to be contaminated should be collected in plastic bags. Persons who convey the bags and launder the clothing should be advised of the

hazard and trained in proper handling. The clothing may be put into a washer without contact if the launderer knows of the potential problem. The washer should be run through a cycle before being used again for other clothing.

5.3.10 Wipe tests—A useful method of determining cleanliness of work surfaces and tools is to wipe the surface with a piece of filter paper. Extraction and analysis by GC with an electron capture detector (ECD) can achieve a limit of detection of 0.1 µg per wipe; analysis using this method can achieve an even lower detection limit. Less than 0.1 µg per wipe indicates acceptable cleanliness; anything higher warrants further cleaning. More than 10 µg on a wipe constitutes an acute hazard and requires prompt cleaning before further use of the equipment or work space, and indicates that unacceptable work practices have been employed.

5.3.11 Table or wrist-action shaker—The use of a table or wrist-action shaker for extraction of tissues presents the possibility of breakage of the extraction bottle and spillage of acid and flammable organic solvent. A secondary containment system around the shaker is suggested to prevent the spread of acid and solvents in the event of such a breakage. The speed and intensity of shaking action should also be adjusted to minimize the possibility of breakage.

6.0 Apparatus and Materials

NOTE: Brand names, suppliers, and part numbers are for illustration purposes only and no endorsement is implied. Equivalent performance may be achieved using apparatus and materials other than those specified here. Meeting the performance requirements of this method is the responsibility of the laboratory.

6.1 Sampling Equipment for Discrete or Composite Sampling

6.1.1 Sample bottles and caps

6.1.1.1 Liquid samples (waters, sludges and similar materials containing 5% solids or less)—Sample bottle, amber glass, 1.1 L minimum, with screw cap.

6.1.1.2 Solid samples (soils, sediments, sludges, paper pulps, filter cake, compost, and similar materials that contain more than 5% solids)—Sample bottle, wide mouth, amber glass, 500 mL minimum.

6.1.1.3 If amber bottles are not available, samples shall be protected from light.

6.1.1.4 Bottle caps—Threaded to fit sample bottles. Caps shall be lined with fluoropolymer.

6.1.1.5 Cleaning

6.1.1.5.1 Bottles are detergent water washed, then solvent rinsed before use.

- 6.1.1.5.2 Liners are detergent water washed, rinsed with reagent water (Section 7.6.1) followed by solvent, and baked at approximately 200°C for a minimum of 1 hour prior to use.
- 6.1.2 Compositing equipment—Automatic or manual compositing system incorporating glass containers cleaned per bottle cleaning procedure above. Only glass or fluoropolymer tubing shall be used. If the sampler uses a peristaltic pump, a minimum length of compressible silicone rubber tubing may be used in the pump only. Before use, the tubing shall be thoroughly rinsed with methanol, followed by repeated rinsing with reagent water to minimize sample contamination. An integrating flow meter is used to collect proportional composite samples.
- 6.2 Equipment for Glassware Cleaning—Laboratory sink with overhead fume hood.
- 6.3 Equipment for Sample Preparation
- 6.3.1 Laboratory fume hood of sufficient size to contain the sample preparation equipment listed below.
- 6.3.2 Glove box (optional).
- 6.3.3 Tissue homogenizer—VirTis Model 45 Macro homogenizer (American Scientific Products H-3515, or equivalent) with stainless steel Macro-shaft and Turbo-shear blade.
- 6.3.4 Meat grinder—Hobart, or equivalent, with 3-5 mm holes in inner plate.
- 6.3.5 Equipment for determining percent moisture
- 6.3.5.1 Oven—Capable of maintaining a temperature of 110 ±5°C.
- 6.3.5.2 Dessicator.
- 6.3.6 Balances
- 6.3.6.1 Analytical—Capable of weighing 0.1 mg.
- 6.3.6.2 Top loading—Capable of weighing 10 mg.
- 6.4 Extraction Apparatus
- 6.4.1 Water samples
- 6.4.1.1 pH meter, with combination glass electrode.
- 6.4.1.2 pH paper, wide range (Hydrion Papers, or equivalent).
- 6.4.1.3 Graduated cylinder, 1 L capacity.
- 6.4.1.4 Liquid/liquid extraction—Separatory funnels, 250 mL, 500 mL, and 2000 mL, with fluoropolymer stopcocks.

6.4.1.5 Solid-phase extraction

- 6.4.1.5.1 One liter filtration apparatus, including glass funnel, glass frit support, clamp, adapter, stopper, filtration flask, and vacuum tubing (Figure 4). For wastewater samples, the apparatus should accept 90 or 144 mm disks. For drinking water or other samples containing low solids, smaller disks may be used.
 - 6.4.1.5.2 Vacuum source capable of maintaining 25 in. Hg, equipped with shutoff valve and vacuum gauge.
 - 6.4.1.5.3 Glass-fiber filter—Whatman GMF 150 (or equivalent), 1 micron pore size, to fit filtration apparatus in Section 6.4.1.5.1.
 - 6.4.1.5.4 Solid-phase extraction disk containing octadecyl (C₁₈) bonded silica uniformly enmeshed in an inert matrix—Fisher Scientific 14-378F (or equivalent), to fit filtration apparatus in Section 6.4.1.5.1.
- 6.4.2 Soxhlet/Dean-Stark (SDS) extractor (Figure 5)—For filters and solid/sludge samples.
- 6.4.2.1 Soxhlet—50 mm ID, 200 mL capacity with 500 mL flask (Cal-Glass LG-6900, or equivalent, except substitute 500 mL round-bottom flask for 300 mL flat-bottom flask).
 - 6.4.2.2 Thimble—43 x 123 to fit Soxhlet (Cal-Glass LG-6901-122, or equivalent).
 - 6.4.2.3 Moisture trap—Dean Stark or Barret with fluoropolymer stopcock, to fit Soxhlet.
 - 6.4.2.4 Heating mantle—Hemispherical, to fit 500 mL round-bottom flask (Cal-Glass LG-8801-112, or equivalent).
 - 6.4.2.5 Variable transformer—Powerstat (or equivalent), 110 volt, 10 amp.
- 6.4.3 Apparatus for extraction of tissue.
- 6.4.3.1 Bottle for extraction (if digestion/extraction using HCl is used)—500-600 mL wide-mouth clear glass, with fluoropolymer-lined cap.
 - 6.4.3.2 Bottle for back-extraction—100-200 mL narrow-mouth clear glass with fluoropolymer-lined cap.
 - 6.4.3.3 Mechanical shaker—Wrist-action or platform-type rotary shaker that produces vigorous agitation (Sybron Thermolyne Model LE "Big Bill" rotator/shaker, or equivalent).

6.4.3.4 Rack attached to shaker table to permit agitation of four to nine samples simultaneously.

6.4.4 Beakers—400-500 mL.

6.4.5 Spatulas—Stainless steel.

6.5 Filtration Apparatus

6.5.1 Pyrex glass wool—Solvent-extracted by SDS for three hours minimum.

NOTE: Baking glass wool may cause active sites that will irreversibly adsorb CDDs/CDFs.

6.5.2 Glass funnel—125-250 mL.

6.5.3 Glass-fiber filter paper—Whatman GF/D (or equivalent), to fit glass funnel in Section 6.5.2.

6.5.4 Drying column—15-20 mm ID Pyrex chromatographic column equipped with coarse-glass frit or glass-wool plug.

6.5.5 Buchner funnel—15 cm.

6.5.6 Glass-fiber filter paper—to fit Buchner funnel in Section 6.5.5.

6.5.7 Filtration flasks—1.5-2.0 L, with side arm.

6.5.8 Pressure filtration apparatus—Millipore YT30 142 HW, or equivalent.

6.6 Centrifuge Apparatus

6.6.1 Centrifuge—Capable of rotating 500 mL centrifuge bottles or 15 mL centrifuge tubes at 5,000 rpm minimum.

6.6.2 Centrifuge bottles—500 mL, with screw-caps, to fit centrifuge.

6.6.3 Centrifuge tubes—12-15 mL, with screw-caps, to fit centrifuge.

6.7 Cleanup Apparatus

6.7.1 Automated gel permeation chromatograph (Analytical Biochemical Labs, Inc, Columbia, MO, Model GPC Autoprep 1002, or equivalent).

6.7.1.1 Column—600-700 mm long x 25 mm ID, packed with 70 g of SX-3 Bio-beads (Bio-Rad Laboratories, Richmond, CA, or equivalent).

6.7.1.2 Syringe—10 mL, with Luer fitting.

6.7.1.3 Syringe filter holder—stainless steel, and glass-fiber or fluoropolymer filters (Gelman 4310, or equivalent).

- 6.7.1.4 UV detectors—254 nm, preparative or semi-preparative flow cell (Isco, Inc., Type 6; Schmadzu, 5 mm path length; Beckman-Altex 152W, 8 μ L micro-prep flow cell, 2 mm path; Pharmacia UV-1, 3 mm flow cell; LDC Milton-Roy UV-3, monitor #1203; or equivalent).
- 6.7.2 Reverse-phase high-performance liquid chromatograph.
- 6.7.2.1 Column oven and detector—Perkin-Elmer Model LC-65T (or equivalent) operated at 0.02 AUFS at 235 nm.
- 6.7.2.2 Injector—Rheodyne 7120 (or equivalent) with 50 μ L sample loop.
- 6.7.2.3 Column—Two 6.2 mm x 250 mm Zorbax-ODS columns in series (DuPont Instruments Division, Wilmington, DE, or equivalent), operated at 50°C with 2.0 mL/min methanol isocratic effluent.
- 6.7.2.4 Pump—Altex 110A (or equivalent).
- 6.7.3 Pipets
- 6.7.3.1 Disposable, pasteur—150 mm long x 5-mm ID (Fisher Scientific 13-678-6A, or equivalent).
- 6.7.3.2 Disposable, serological—10 mL (6 mm ID).
- 6.7.4 Glass chromatographic columns
- 6.7.4.1 150 mm long x 8-mm ID, (Kontes K-420155, or equivalent) with coarse-glass frit or glass-wool plug and 250 mL reservoir.
- 6.7.4.2 200 mm long x 15 mm ID, with coarse-glass frit or glass-wool plug and 250 mL reservoir.
- 6.7.4.3 300 mm long x 25 mm ID, with 300 mL reservoir and glass or fluoropolymer stopcock.
- 6.7.5 Stirring apparatus for batch silica cleanup of tissue extracts.
- 6.7.5.1 Mechanical stirrer—Corning Model 320, or equivalent.
- 6.7.5.2 Bottle—500-600 mL wide-mouth clear glass.
- 6.7.6 Oven—For baking and storage of adsorbents, capable of maintaining a constant temperature ($\pm 5^\circ\text{C}$) in the range of 105-250°C.
- 6.8 Concentration Apparatus
- 6.8.1 Rotary evaporator—Buchi/Brinkman-American Scientific No. E5045-10 or equivalent, equipped with a variable temperature water bath.

- 6.8.1.1 Vacuum source for rotary evaporator equipped with shutoff valve at the evaporator and vacuum gauge.
- 6.8.1.2 A recirculating water pump and chiller are recommended, as use of tap water for cooling the evaporator wastes large volumes of water and can lead to inconsistent performance as water temperatures and pressures vary.
- 6.8.1.3 Round-bottom flask—100 mL and 500 mL or larger, with ground-glass fitting compatible with the rotary evaporator.
- 6.8.2 Kuderna-Danish (K-D) Concentrator
 - 6.8.2.1 Concentrator tube—10 mL, graduated (Kontes K-570050-1025, or equivalent) with calibration verified. Ground-glass stopper (size 19/22 joint) is used to prevent evaporation of extracts.
 - 6.8.2.2 Evaporation flask—500 mL (Kontes K-570001-0500, or equivalent), attached to concentrator tube with springs (Kontes K-662750-0012 or equivalent).
 - 6.8.2.3 Snyder column—Three-ball macro (Kontes K-503000-0232, or equivalent).
 - 6.8.2.4 Boiling chips
 - 6.8.2.4.1 Glass or silicon carbide—Approximately 10/40 mesh, extracted with methylene chloride and baked at 450°C for one hour minimum.
 - 6.8.2.4.2 Fluoropolymer (optional)—Extracted with methylene chloride.
 - 6.8.2.5 Water bath—Heated, with concentric ring cover, capable of maintaining a temperature within $\pm 2^\circ\text{C}$, installed in a fume hood.
- 6.8.3 Nitrogen blowdown apparatus—Equipped with water bath controlled in the range of 30-60°C (N-Evap, Organomation Associates, Inc., South Berlin, MA, or equivalent), installed in a fume hood.
- 6.8.4 Sample vials
 - 6.8.4.1 Amber glass—2-5 mL with fluoropolymer-lined screw-cap.
 - 6.8.4.2 Glass—0.3 mL, conical, with fluoropolymer-lined screw or crimp cap.
- 6.9 Gas Chromatograph—Shall have splitless or on-column injection port for capillary column, temperature program with isothermal hold, and shall meet all of the performance specifications in Section 10.
 - 6.9.1 GC column for CDDs/CDFs and for isomer specificity for 2,3,7,8-TCDD—60 \pm 5 m long x 0.32 \pm 0.02 mm ID; 0.25 μm 5% phenyl, 94% methyl, 1% vinyl silicone bonded-phase fused-silica capillary column (J&W DB-5, or equivalent).

- 6.9.2 GC column for isomer specificity for 2,3,7,8-TCDF—30 ±5 m long x 0.32 ±0.02 mm ID; 0.25 µm bonded-phase fused-silica capillary column (J&W DB-225, or equivalent).
- 6.10 Mass Spectrometer—28-40 eV electron impact ionization, shall be capable of repetitively selectively monitoring 12 exact m/z's minimum at high resolution (≥10,000) during a period of approximately one second, and shall meet all of the performance specifications in Section 10.
- 6.11 GC/MS Interface—The mass spectrometer (MS) shall be interfaced to the GC such that the end of the capillary column terminates within 1 cm of the ion source but does not intercept the electron or ion beams.
- 6.12 Data System—Capable of collecting, recording, and storing MS data.

7.0 Reagents and Standards

7.1 pH Adjustment and Back-Extraction

- 7.1.1 Potassium hydroxide—Dissolve 20 g reagent grade KOH in 100 mL reagent water.
- 7.1.2 Sulfuric acid—Reagent grade (specific gravity 1.84).
- 7.1.3 Hydrochloric acid—Reagent grade, 6N.
- 7.1.4 Sodium chloride—Reagent grade, prepare at 5% (w/v) solution in reagent water.

7.2 Solution Drying and Evaporation

- 7.2.1 Solution drying—Sodium sulfate, reagent grade, granular, anhydrous (Baker 3375, or equivalent), rinsed with methylene chloride (20 mL/g), baked at 400°C for one hour minimum, cooled in a dessicator, and stored in a pre-cleaned glass bottle with screw-cap that prevents moisture from entering. If, after heating, the sodium sulfate develops a noticeable grayish cast (due to the presence of carbon in the crystal matrix), that batch of reagent is not suitable for use and should be discarded. Extraction with methylene chloride (as opposed to simple rinsing) and baking at a lower temperature may produce sodium sulfate that is suitable for use.
- 7.2.2 Tissue drying—Sodium sulfate, reagent grade, powdered, treated and stored as above.
- 7.2.3 Prepurified nitrogen.

7.3 Extraction

- 7.3.1 Solvents—Acetone, toluene, cyclohexane, hexane, methanol, methylene chloride, and nonane; distilled in glass, pesticide quality, lot-certified to be free of interferences.

- 7.3.2 White quartz sand, 60/70 mesh—For Soxhlet/Dean-Stark extraction (Aldrich Chemical, Cat. No. 27-437-9, or equivalent). Bake at 450°C for four hours minimum.
- 7.4 GPC Calibration Solution—Prepare a solution containing 300 mg/mL corn oil, 15 mg/mL bis(2-ethylhexyl) phthalate, 1.4 mg/mL pentachlorophenol, 0.1 mg/mL perylene, and 0.5 mg/mL sulfur.
- 7.5 Adsorbents for Sample Cleanup
- 7.5.1 Silica gel
- 7.5.1.1 Activated silica gel—100-200 mesh, Supelco 1-3651 (or equivalent), rinsed with methylene chloride, baked at 180°C for a minimum of one hour, cooled in a dessicator, and stored in a precleaned glass bottle with screw-cap that prevents moisture from entering.
- 7.5.1.2 Acid silica gel (30% w/w)—Thoroughly mix 44.0 g of concentrated sulfuric acid with 100.0 g of activated silica gel in a clean container. Break up aggregates with a stirring rod until a uniform mixture is obtained. Store in a bottle with a fluoropolymer-lined screw-cap.
- 7.5.1.3 Basic silica gel—Thoroughly mix 30 g of 1N sodium hydroxide with 100 g of activated silica gel in a clean container. Break up aggregates with a stirring rod until a uniform mixture is obtained. Store in a bottle with a fluoropolymer-lined screw-cap.
- 7.5.1.4 Potassium silicate
- 7.5.1.4.1 Dissolve 56 g of high purity potassium hydroxide (Aldrich, or equivalent) in 300 mL of methanol in a 750-1000 mL flat-bottom flask.
- 7.5.1.4.2 Add 100 g of silica gel and a stirring bar, and stir on a hot plate at 60-70°C for one to two hours.
- 7.5.1.4.3 Decant the liquid and rinse the potassium silicate twice with 100 mL portions of methanol, followed by a single rinse with 100 mL of methylene chloride.
- 7.5.1.4.4 Spread the potassium silicate on solvent-rinsed aluminum foil and dry for two to four hours in a hood.
- 7.5.1.4.5 Activate overnight at 200-250°C.
- 7.5.2 Alumina—Either one of two types of alumina, acid or basic, may be used in the cleanup of sample extracts, provided that the laboratory can meet the performance specifications for the recovery of labeled compounds described in Section 9.3. The same type of alumina must be used for all samples, including those used to demonstrate initial precision and recovery (Section 9.2) and ongoing precision and recovery (Section 15.5).

- 7.5.2.1 Acid alumina—Supelco 19996-6C (or equivalent). Activate by heating to 130°C for a minimum of 12 hours.
- 7.5.2.2 Basic alumina—Supelco 19944-6C (or equivalent). Activate by heating to 600°C for a minimum of 24 hours. Alternatively, activate by heating in a tube furnace at 650-700°C under an air flow rate of approximately 400 cc/minute. Do not heat over 700°C, as this can lead to reduced capacity for retaining the analytes. Store at 130°C in a covered flask. Use within five days of baking.
- 7.5.3 Carbon
- 7.5.3.1 Carbpak C—(Supelco 1-0258, or equivalent).
- 7.5.3.2 Celite 545—(Supelco 2-0199, or equivalent).
- 7.5.3.3 Thoroughly mix 9.0 g Carbpak C and 41.0 g Celite 545 to produce an 18% w/w mixture. Activate the mixture at 130°C for a minimum of six hours. Store in a dessicator.
- 7.5.4 Anthropogenic isolation column—Pack the column in Section 6.7.4.3 from bottom to top with the following:
- 7.5.4.1 2 g silica gel (Section 7.5.1.1).
- 7.5.4.2 2 g potassium silicate (Section 7.5.1.4).
- 7.5.4.3 2 g granular anhydrous sodium sulfate (Section 7.2.1).
- 7.5.4.4 10 g acid silica gel (Section 7.5.1.2).
- 7.5.4.5 2 g granular anhydrous sodium sulfate.
- 7.5.5 Florisil column
- 7.5.5.1 Florisil—60-100 mesh, Floridin Corp (or equivalent). Soxhlet extract in 500 g portions for 24 hours.
- 7.5.5.2 Insert a glass wool plug into the tapered end of a graduated serological pipet (Section 6.7.3.2). Pack with 1.5 g (approx 2 mL) of Florisil topped with approx 1 mL of sodium sulfate (Section 7.2.1) and a glass wool plug.
- 7.5.5.3 Activate in an oven at 130-150°C for a minimum of 24 hours and cool for 30 minutes. Use within 90 minutes of cooling.
- 7.6 Reference Matrices—Matrices in which the CDDs/CDFs and interfering compounds are not detected by this method.
- 7.6.1 Reagent water—Bottled water purchased locally, or prepared by passage through activated carbon.

- 7.6.2 High-solids reference matrix—Playground sand or similar material. Prepared by extraction with methylene chloride and/or baking at 450°C for a minimum of four hours.
- 7.6.3 Paper reference matrix—Glass-fiber filter, Gelman Type A, or equivalent. Cut paper to simulate the surface area of the paper sample being tested.
- 7.6.4 Tissue reference matrix—Corn or other vegetable oil. May be prepared by extraction with methylene chloride.
- 7.6.5 Other matrices—This method may be verified on any reference matrix by performing the tests given in Section 9.2. Ideally, the matrix should be free of the CDDs/CDFs, but in no case shall the background level of the CDDs/CDFs in the reference matrix exceed three times the minimum levels in Table 2. If low background levels of the CDDs/CDFs are present in the reference matrix, the spike level of the analytes used in Section 9.2 should be increased to provide a spike-to-background ratio in the range of 1:1 to 5:1 (Reference 15).
- 7.7 Standard Solutions—Purchased as solutions or mixtures with certification to their purity, concentration, and authenticity, or prepared from materials of known purity and composition. If the chemical purity is 98% or greater, the weight may be used without correction to compute the concentration of the standard. When not being used, standards are stored in the dark at room temperature in screw-capped vials with fluoropolymer-lined caps. A mark is placed on the vial at the level of the solution so that solvent loss by evaporation can be detected. If solvent loss has occurred, the solution should be replaced.
- 7.8 Stock Solutions
- 7.8.1 Preparation—Prepare in nonane per the steps below or purchase as dilute solutions (Cambridge Isotope Laboratories (CIL), Woburn, MA, or equivalent). Observe the safety precautions in Section 5, and the recommendation in Section 5.1.2.
- 7.8.2 Dissolve an appropriate amount of assayed reference material in solvent. For example, weigh 1-2 mg of 2,3,7,8-TCDD to three significant figures in a 10 mL ground-glass-stoppered volumetric flask and fill to the mark with nonane. After the TCDD is completely dissolved, transfer the solution to a clean 15 mL vial with fluoropolymer-lined cap.
- 7.8.3 Stock standard solutions should be checked for signs of degradation prior to the preparation of calibration or performance test standards. Reference standards that can be used to determine the accuracy of calibration standards are available from CIL and may be available from other vendors.
- 7.9 PAR Stock Solution
- 7.9.1 All CDDs/CDFs—Using the solutions in Section 7.8, prepare the PAR stock solution to contain the CDDs/CDFs at the concentrations shown in Table 3. When diluted, the solution will become the PAR (Section 7.14).

- 7.9.2 If only 2,3,7,8-TCDD and 2,3,7,8-TCDF are to be determined, prepare the PAR stock solution to contain these compounds only.
- 7.10 Labeled-Compound Spiking Solution
- 7.10.1 All CDDs/CDFs—From stock solutions, or from purchased mixtures, prepare this solution to contain the labeled compounds in nonane at the concentrations shown in Table 3. This solution is diluted with acetone prior to use (Section 7.10.3).
- 7.10.2 If only 2,3,7,8-TCDD and 2,3,7,8-TCDF are to be determined, prepare the labeled-compound solution to contain these compounds only. This solution is diluted with acetone prior to use (Section 7.10.3).
- 7.10.3 Dilute a sufficient volume of the labeled compound solution (Section 7.10.1 or 7.10.2) by a factor of 50 with acetone to prepare a diluted spiking solution. Each sample requires 1.0 mL of the diluted solution, but no more solution should be prepared than can be used in one day.
- 7.11 Cleanup Standard—Prepare $^{37}\text{Cl}_4$ -2,3,7,8-TCDD in nonane at the concentration shown in Table 3. The cleanup standard is added to all extracts prior to cleanup to measure the efficiency of the cleanup process.
- 7.12 Internal Standard(s)
- 7.12.1 All CDDs/CDFs—Prepare the internal standard solution to contain $^{13}\text{C}_{12}$ -1,2,3,4-TCDD and $^{13}\text{C}_{12}$ -1,2,3,7,8,9-HxCDD in nonane at the concentration shown in Table 3.
- 7.12.2 If only 2,3,7,8-TCDD and 2,3,7,8-TCDF are to be determined, prepare the internal standard solution to contain $^{13}\text{C}_{12}$ -1,2,3,4-TCDD only.
- 7.13 Calibration Standards (CS1 through CS5)—Combine the solutions in Sections 7.9 through 7.12 to produce the five calibration solutions shown in Table 4 in nonane. These solutions permit the relative response (labeled to native) and response factor to be measured as a function of concentration. The CS3 standard is used for calibration verification (VER). If only 2,3,7,8-TCDD and 2,3,7,8-TCDF are to be determined, combine the solutions appropriate to these compounds.
- 7.14 Precision and Recovery (PAR) Standard—Used for determination of initial (Section 9.2) and ongoing (Section 15.5) precision and recovery. Dilute 10 μL of the precision and recovery standard (Section 7.9.1 or 7.9.2) to 2.0 mL with acetone for each sample matrix for each sample batch. One mL each are required for the blank and OPR with each matrix in each batch.
- 7.15 GC Retention Time Window Defining Solution and Isomer Specificity Test Standard—Used to define the beginning and ending retention times for the dioxin and furan isomers and to demonstrate isomer specificity of the GC columns employed for determination of 2,3,7,8-TCDD and 2,3,7,8-TCDF. The standard must contain the compounds listed in Table 5 (CIL EDF-4006, or equivalent), at a minimum. It is not necessary to monitor the window-defining compounds if only 2,3,7,8-TCDD and 2,3,7,8-TCDF are to be

determined. In this case, an isomer-specificity test standard containing the most closely eluted isomers listed in Table 5 (CIL EDF-4033, or equivalent) may be used.

- 7.16 **QC Check Sample**—A QC Check Sample should be obtained from a source independent of the calibration standards. Ideally, this check sample would be a certified reference material containing the CDDs/CDFs in known concentrations in a sample matrix similar to the matrix under test.
- 7.17 **Stability of Solutions**—Standard solutions used for quantitative purposes (Sections 7.9 through 7.15) should be analyzed periodically, and should be assayed against reference standards (Section 7.8.3) before further use.

8.0 Sample Collection, Preservation, Storage, and Holding Times

- 8.1 Collect samples in amber glass containers following conventional sampling practices (Reference 16). Aqueous samples that flow freely are collected in refrigerated bottles using automatic sampling equipment. Solid samples are collected as grab samples using wide-mouth jars.
- 8.2 Maintain aqueous samples in the dark at 0-4°C from the time of collection until receipt at the laboratory. If residual chlorine is present in aqueous samples, add 80 mg sodium thiosulfate per liter of water. EPA Methods 330.4 and 330.5 may be used to measure residual chlorine (Reference 17). If sample pH is greater than 9, adjust to pH 7-9 with sulfuric acid.

Maintain solid, semi-solid, oily, and mixed-phase samples in the dark at <4°C from the time of collection until receipt at the laboratory.

Store aqueous samples in the dark at 0-4°C. Store solid, semi-solid, oily, mixed-phase, and tissue samples in the dark at <-10°C.

8.3 Fish and Tissue Samples

- 8.3.1 Fish may be cleaned, filleted, or processed in other ways in the field, such that the laboratory may expect to receive whole fish, fish fillets, or other tissues for analysis.
- 8.3.2 Fish collected in the field should be wrapped in aluminum foil, and must be maintained at a temperature less than 4°C from the time of collection until receipt at the laboratory.
- 8.3.3 Samples must be frozen upon receipt at the laboratory and maintained in the dark at <-10°C until prepared. Maintain unused sample in the dark at <-10°C.

8.4 Holding Times

- 8.4.1 There are no demonstrated maximum holding times associated with CDDs/CDFs in aqueous, solid, semi-solid, tissues, or other sample matrices. If stored in the dark at 0-4°C and preserved as given above (if required), aqueous samples may be stored for up to one year. Similarly, if stored in the dark at <-10°C, solid, semi-solid, multi-phase, and tissue samples may be stored for up to one year.

- 8.4.2 Store sample extracts in the dark at $<-10^{\circ}\text{C}$ until analyzed. If stored in the dark at $<-10^{\circ}\text{C}$, sample extracts may be stored for up to one year.

9.0 Quality Assurance/Quality Control

- 9.1 Each laboratory that uses this method is required to operate a formal quality assurance program (Reference 18). The minimum requirements of this program consist of an initial demonstration of laboratory capability, analysis of samples spiked with labeled compounds to evaluate and document data quality, and analysis of standards and blanks as tests of continued performance. Laboratory performance is compared to established performance criteria to determine if the results of analyses meet the performance characteristics of the method.

If the method is to be applied to sample matrix other than water (e.g., soils, filter cake, compost, tissue) the most appropriate alternate matrix (Sections 7.6.2 through 7.6.5) is substituted for the reagent water matrix (Section 7.6.1) in all performance tests.

- 9.1.1 The analyst shall make an initial demonstration of the ability to generate acceptable accuracy and precision with this method. This ability is established as described in Section 9.2.

- 9.1.2 In recognition of advances that are occurring in analytical technology, and to allow the analyst to overcome sample matrix interferences, the analyst is permitted certain options to improve separations or lower the costs of measurements. These options include alternate extraction, concentration, cleanup procedures, and changes in columns and detectors. Alternate determinative techniques, such as the substitution of spectroscopic or immuno-assay techniques, and changes that degrade method performance, are not allowed. If an analytical technique other than the techniques specified in this method is used, that technique must have a specificity equal to or better than the specificity of the techniques in this method for the analytes of interest.

- 9.1.2.1 Each time a modification is made to this method, the analyst is required to repeat the procedure in Section 9.2. If the detection limit of the method will be affected by the change, the laboratory is required to demonstrate that the MDL (40 CFR Part 136, Appendix B) is lower than one-third the regulatory compliance level or one-third the ML in this method, whichever is higher. If calibration will be affected by the change, the analyst must recalibrate the instrument per Section 10.

- 9.1.2.2 The laboratory is required to maintain records of modifications made to this method. These records include the following, at a minimum:

9.1.2.2.1 The names, titles, addresses, and telephone numbers of the analyst(s) who performed the analyses and modification, and of the quality control officer who witnessed and will verify the analyses and modifications.

9.1.2.2.2 A listing of pollutant(s) measured, by name and CAS Registry number.

-
- 9.1.2.2.3 A narrative stating reason(s) for the modifications.
- 9.1.2.2.4 Results from all quality control (QC) tests comparing the modified method to this method, including:
- a) Calibration (Section 10.5 through 10.7).
 - b) Calibration verification (Section 15.3).
 - c) Initial precision and recovery (Section 9.2).
 - d) Labeled compound recovery (Section 9.3).
 - e) Analysis of blanks (Section 9.5).
 - f) Accuracy assessment (Section 9.4).
- 9.1.2.2.5 Data that will allow an independent reviewer to validate each determination by tracing the instrument output (peak height, area, or other signal) to the final result. These data are to include:
- a) Sample numbers and other identifiers.
 - b) Extraction dates.
 - c) Analysis dates and times.
 - d) Analysis sequence/run chronology.
 - e) Sample weight or volume (Section 11).
 - f) Extract volume prior to each cleanup step (Section 13).
 - g) Extract volume after each cleanup step (Section 13).
 - h) Final extract volume prior to injection (Section 14).
 - i) Injection volume (Section 14.3).
 - j) Dilution data, differentiating between dilution of a sample or extract (Section 17.5).
 - k) Instrument and operating conditions.
 - l) Column (dimensions, liquid phase, solid support, film thickness, etc).
 - m) Operating conditions (temperatures, temperature program, flow rates).
 - n) Detector (type, operating conditions, etc).
 - o) Chromatograms, printer tapes, and other recordings of raw data.
 - p) Quantitation reports, data system outputs, and other data to link the raw data to the results reported.
- 9.1.3 Analyses of method blanks are required to demonstrate freedom from contamination (Section 4.3). The procedures and criteria for analysis of a method blank are described in Sections 9.5 and 15.6.
- 9.1.4 The laboratory shall spike all samples with labeled compounds to monitor method performance. This test is described in Section 9.3. When results of these spikes indicate atypical method performance for samples, the samples are diluted to bring method performance within acceptable limits. Procedures for dilution are given in Section 17.5.
- 9.1.5 The laboratory shall, on an ongoing basis, demonstrate through calibration verification and the analysis of the ongoing precision and recovery aliquot that

- the analytical system is in control. These procedures are described in Sections 15.1 through 15.5.
- 9.1.6 The laboratory shall maintain records to define the quality of data that is generated. Development of accuracy statements is described in Section 9.4.
- 9.2 Initial Precision and Recovery (IPR)—To establish the ability to generate acceptable precision and recovery, the analyst shall perform the following operations.
- 9.2.1 For low solids (aqueous) samples, extract, concentrate, and analyze four 1 L aliquots of reagent water spiked with the diluted labeled compound spiking solution (Section 7.10.3) and the precision and recovery standard (Section 7.14) according to the procedures in Sections 11 through 18. For an alternative sample matrix, four aliquots of the alternative reference matrix (Section 7.6) are used. All sample processing steps that are to be used for processing samples, including preparation (Section 11), extraction (Section 12), and cleanup (Section 13), shall be included in this test.
- 9.2.2 Using results of the set of four analyses, compute the average concentration (X) of the extracts in ng/mL and the standard deviation of the concentration (s) in ng/mL for each compound, by isotope dilution for CDDs/CDFs with a labeled analog, and by internal standard for 1,2,3,7,8,9-HxCDD, OCDF, and the labeled compounds.
- 9.2.3 For each CDD/CDF and labeled compound, compare s and X with the corresponding limits for initial precision and recovery in Table 6. If only 2,3,7,8-TCDD and 2,3,7,8-TCDF are to be determined, compare s and X with the corresponding limits for initial precision and recovery in Table 6a. If s and X for all compounds meet the acceptance criteria, system performance is acceptable and analysis of blanks and samples may begin. If, however, any individual s exceeds the precision limit or any individual X falls outside the range for accuracy, system performance is unacceptable for that compound. Correct the problem and repeat the test (Section 9.2).
- 9.3 The laboratory shall spike all samples with the diluted labeled compound spiking solution (Section 7.10.3) to assess method performance on the sample matrix.
- 9.3.1 Analyze each sample according to the procedures in Sections 11 through 18.
- 9.3.2 Compute the percent recovery of the labeled compounds and the cleanup standard using the internal standard method (Section 17.2).
- 9.3.3 The recovery of each labeled compound must be within the limits in Table 7 when all 2,3,7,8-substituted CDDs/CDFs are determined, and within the limits in Table 7a when only 2,3,7,8-TCDD and 2,3,7,8-TCDF are determined. If the recovery of any compound falls outside of these limits, method performance is unacceptable for that compound in that sample. To overcome such difficulties, water samples are diluted and smaller amounts of soils, sludges, sediments, and other matrices are reanalyzed per Section 18.4.

- 9.4 Recovery of labeled compounds from samples should be assessed and records should be maintained.
- 9.4.1 After the analysis of five samples of a given matrix type (water, soil, sludge, pulp, etc.) for which the labeled compounds pass the tests in Section 9.3, compute the average percent recovery (R) and the standard deviation of the percent recovery (S_R) for the labeled compounds only. Express the assessment as a percent recovery interval from $R-2S_R$ to $R+2S_R$ for each matrix. For example, if $R = 90\%$ and $S_R = 10\%$ for five analyses of pulp, the recovery interval is expressed as 70-110%.
- 9.4.2 Update the accuracy assessment for each labeled compound in each matrix on a regular basis (e.g., after each 5-10 new measurements).
- 9.5 Method Blanks—Reference matrix method blanks are analyzed to demonstrate freedom from contamination (Section 4.3).
- 9.5.1 Prepare, extract, clean up, and concentrate a method blank with each sample batch (samples of the same matrix started through the extraction process on the same 12-hour shift, to a maximum of 20 samples). The matrix for the method blank shall be similar to sample matrix for the batch, e.g., a 1 L reagent water blank (Section 7.6.1), high-solids reference matrix blank (Section 7.6.2), paper matrix blank (Section 7.6.3); tissue blank (Section 7.6.4) or alternative reference matrix blank (Section 7.6.5). Analyze the blank immediately after analysis of the OPR (Section 15.5) to demonstrate freedom from contamination.
- 9.5.2 If any 2,3,7,8-substituted CDD/CDF (Table 1) is found in the blank at greater than the minimum level (Table 2) or one-third the regulatory compliance level, whichever is greater; or if any potentially interfering compound is found in the blank at the minimum level for each level of chlorination given in Table 2 (assuming a response factor of 1 relative to the $^{13}\text{C}_{12}$ -1,2,3,4-TCDD internal standard for compounds not listed in Table 1), analysis of samples is halted until the blank associated with the sample batch shows no evidence of contamination at this level. All samples must be associated with an uncontaminated method blank before the results for those samples may be reported for regulatory compliance purposes.
- 9.6 QC Check Sample—Analyze the QC Check Sample (Section 7.16) periodically to assure the accuracy of calibration standards and the overall reliability of the analytical process. It is suggested that the QC Check Sample be analyzed at least quarterly.
- 9.7 The specifications contained in this method can be met if the apparatus used is calibrated properly and then maintained in a calibrated state. The standards used for calibration (Section 10), calibration verification (Section 15.3), and for initial (Section 9.2) and ongoing (Section 15.5) precision and recovery should be identical, so that the most precise results will be obtained. A GC/MS instrument will provide the most reproducible results if dedicated to the settings and conditions required for the analyses of CDDs/CDFs by this method.

- 9.8 Depending on specific program requirements, field replicates may be collected to determine the precision of the sampling technique, and spiked samples may be required to determine the accuracy of the analysis when the internal standard method is used.

10.0 Calibration

- 10.1 Establish the operating conditions necessary to meet the minimum retention times for the internal standards in Section 10.2.4 and the relative retention times for the CDDs/CDFs in Table 2.

10.1.1 Suggested GC operating conditions:

Injector temperature: 270°C
Interface temperature: 290°C
Initial temperature: 200°C
Initial time: Two minutes
Temperature program: 200-220°C, at 5°C/minute
220°C for 16 minutes
220-235°C, at 5°C/minute
235°C for seven minutes
235-330°C, at 5°C/minute

NOTE: All portions of the column that connect the GC to the ion source shall remain at or above the interface temperature specified above during analysis to preclude condensation of less volatile compounds.

Optimize GC conditions for compound separation and sensitivity. Once optimized, the same GC conditions must be used for the analysis of all standards, blanks, IPR and OPR aliquots, and samples.

- 10.1.2 Mass spectrometer (MS) resolution—Obtain a selected ion current profile (SICP) of each analyte in Table 3 at the two exact m/z 's specified in Table 8 and at $\geq 10,000$ resolving power by injecting an authentic standard of the CDDs/CDFs either singly or as part of a mixture in which there is no interference between closely eluted components.

10.1.2.1 The analysis time for CDDs/CDFs may exceed the long-term mass stability of the mass spectrometer. Because the instrument is operated in the high-resolution mode, mass drifts of a few ppm (e.g., 5 ppm in mass) can have serious adverse effects on instrument performance. Therefore, a mass-drift correction is mandatory and a lock-mass m/z from PFK is used for drift correction. The lock-mass m/z is dependent on the exact m/z 's monitored within each descriptor, as shown in Table 8. The level of PFK metered into the HRMS during analyses should be adjusted so that the amplitude of the most intense selected lock-mass m/z signal (regardless of the descriptor number) does not exceed 10% of the full-scale deflection for a given set of detector parameters. Under those conditions, sensitivity changes that might occur during the analysis can be more effectively monitored.

NOTE: *Excessive PFK (or any other reference substance) may cause noise problems and contamination of the ion source necessitating increased frequency of source cleaning.*

- 10.1.2.2 If the HRMS has the capability to monitor resolution during the analysis, it is acceptable to terminate the analysis when the resolution falls below 10,000 to save reanalysis time.
- 10.1.2.3 Using a PFK molecular leak, tune the instrument to meet the minimum required resolving power of 10,000 (10% valley) at m/z 304.9824 (PFK) or any other reference signal close to m/z 304 (from TCDF). For each descriptor (Table 8), monitor and record the resolution and exact m/z 's of three to five reference peaks covering the mass range of the descriptor. The resolution must be greater than or equal to 10,000, and the deviation between the exact m/z and the theoretical m/z (Table 8) for each exact m/z monitored must be less than 5 ppm.
- 10.2 Ion Abundance Ratios, Minimum Levels, Signal-to-Noise Ratios, and Absolute Retention Times—Choose an injection volume of either 1 μL or 2 μL , consistent with the capability of the HRGC/HRMS instrument. Inject a 1 μL or 2 μL aliquot of the CS1 calibration solution (Table 4) using the GC conditions from Section 10.1.1. If only 2,3,7,8-TCDD and 2,3,7,8-TCDF are to be determined, the operating conditions and specifications below apply to analysis of those compounds only.
- 10.2.1 Measure the SICP areas for each analyte, and compute the ion abundance ratios at the exact m/z 's specified in Table 8. Compare the computed ratio to the theoretical ratio given in Table 9.
- 10.2.1.1 The exact m/z 's to be monitored in each descriptor are shown in Table 8. Each group or descriptor shall be monitored in succession as a function of GC retention time to ensure that all CDDs/CDFs are detected. Additional m/z 's may be monitored in each descriptor, and the m/z 's may be divided among more than the five descriptors listed in Table 8, provided that the laboratory is able to monitor the m/z 's of all the CDDs/CDFs that may elute from the GC in a given retention-time window. If only 2,3,7,8-TCDD and 2,3,7,8-TCDF are to be determined, the descriptors may be modified to include only the exact m/z 's for the tetra- and penta-isomers, the diphenyl ethers, and the lock m/z 's.
- 10.2.1.2 The mass spectrometer shall be operated in a mass-drift correction mode, using perfluorokerosene (PFK) to provide lock m/z 's. The lock-mass for each group of m/z 's is shown in Table 8. Each lock mass shall be monitored and shall not vary by more than $\pm 20\%$ throughout its respective retention time window. Variations of the lock mass by more than 20% indicate the presence of coeluting interferences that may significantly reduce the sensitivity of the mass spectrometer. Reinjection of another aliquot of the sample extract will not resolve the problem. Additional cleanup of the extract may be required to remove the interferences.

- 10.2.2 All CDDs/CDFs and labeled compounds in the CS1 standard shall be within the QC limits in Table 9 for their respective ion abundance ratios; otherwise, the mass spectrometer shall be adjusted and this test repeated until the m/z ratios fall within the limits specified. If the adjustment alters the resolution of the mass spectrometer, resolution shall be verified (Section 10.1.2) prior to repeat of the test.
- 10.2.3 Verify that the HRGC/HRMS instrument meets the minimum levels in Table 2. The peaks representing the CDDs/CDFs and labeled compounds in the CS1 calibration standard must have signal-to-noise ratios (S/N) greater than or equal to 10.0. Otherwise, the mass spectrometer shall be adjusted and this test repeated until the minimum levels in Table 2 are met.
- 10.2.4 The absolute retention time of $^{13}\text{C}_{12}$ -1,2,3,4-TCDD (Section 7.12) shall exceed 25.0 minutes on the DB-5 column, and the retention time of $^{13}\text{C}_{12}$ -1,2,3,4-TCDD shall exceed 15.0 minutes on the DB-225 column; otherwise, the GC temperature program shall be adjusted and this test repeated until the above-stated minimum retention time criteria are met.
- 10.3 Retention-Time Windows—Analyze the window defining mixtures (Section 7.15) using the optimized temperature program in Section 10.1. Table 5 gives the elution order (first/last) of the window-defining compounds. If 2,3,7,8-TCDD and 2,3,7,8-TCDF only are to be analyzed, this test is not required.
- 10.4 Isomer Specificity
- 10.4.1 Analyze the isomer specificity test standards (Section 7.15) using the procedure in Section 14 and the optimized conditions for sample analysis (Section 10.1.1).
- 10.4.2 Compute the percent valley between the GC peaks that elute most closely to the 2,3,7,8-TCDD and TCDF isomers, on their respective columns, per Figures 6 and 7.
- 10.4.3 Verify that the height of the valley between the most closely eluted isomers and the 2,3,7,8-substituted isomers is less than 25% (computed as $100 \times y$ in Figures 6 and 7). If the valley exceeds 25%, adjust the analytical conditions and repeat the test or replace the GC column and recalibrate (Sections 10.1.2 through 10.7).
- 10.5 Calibration by Isotope Dilution—Isotope dilution calibration is used for the 15 2,3,7,8-substituted CDDs/CDFs for which labeled compounds are added to samples prior to extraction. The reference compound for each CDD/CDF compound is shown in Table 2.
- 10.5.1 A calibration curve encompassing the concentration range is prepared for each compound to be determined. The relative response (RR) (labeled to native) vs. concentration in standard solutions is plotted or computed using a linear regression. Relative response is determined according to the procedures described below. Five calibration points are employed.
- 10.5.2 The response of each CDD/CDF relative to its labeled analog is determined using the area responses of both the primary and secondary exact m/z 's specified in Table 8, for each calibration standard, as follows:

$$RR = \frac{(A1_n + A2_n) C_1}{(A1_1 + A2_1) C_n}$$

where,

$A1_n$ and $A2_n$ = The areas of the primary and secondary m/z's for the CDD/CDF.

$A1_1$ and $A2_1$ = The areas of the primary and secondary m/z's for the labeled compound.

C_1 = The concentration of the labeled compound in the calibration standard (Table 4).

C_n = The concentration of the native compound in the calibration standard (Table 4).

10.5.3 To calibrate the analytical system by isotope dilution, inject a volume of calibration standards CS1 through CS5 (Section 7.13 and Table 4) identical to the volume chosen in Section 10.2, using the procedure in Section 14 and the conditions in Section 10.1.1 and Table 2. Compute the relative response (RR) at each concentration.

10.5.4 Linearity—If the relative response for any compound is constant (less than 20% coefficient of variation) over the five-point calibration range, an averaged relative response may be used for that compound; otherwise, the complete calibration curve for that compound shall be used over the five-point calibration range.

10.6 Calibration by Internal Standard—The internal standard method is applied to determination of 1,2,3,7,8,9-HxCDD (Section 17.1.2), OCDF (Section 17.1.1), the non-2,3,7,8-substituted compounds, and to the determination of labeled compounds for intralaboratory statistics (Sections 9.4 and 15.5.4).

10.6.1 Response factors—Calibration requires the determination of response factors (RF) defined by the following equation:

$$RF = \frac{(A1_s + A2_s) C_{is}}{(A1_{is} + A2_{is}) C_s}$$

where,

$A1_s$ and $A2_s$ = The areas of the primary and secondary m/z's for the CDD/CDF.

$A1_{is}$ and $A2_{is}$ = The areas of the primary and secondary m/z's for the internal standard

C_{is} = The concentration of the internal standard (Table 4).

C_s = The concentration of the compound in the calibration standard (Table 4).

NOTE: There is only one m/z for $^{37}Cl_4$ -2,3,7,8-TCDD. See Table 8.

10.6.2 To calibrate the analytical system by internal standard, inject 1.0 μ L or 2.0 μ L of calibration standards CS1 through CS5 (Section 7.13 and Table 4) using the procedure in Section 14 and the conditions in Section 10.1.1 and Table 2. Compute the response factor (RF) at each concentration.

- 10.6.3 Linearity—If the response factor (RF) for any compound is constant (less than 35% coefficient of variation) over the five-point calibration range, an averaged response factor may be used for that compound; otherwise, the complete calibration curve for that compound shall be used over the five-point range.
- 10.7 Combined Calibration—By using calibration solutions (Section 7.13 and Table 4) containing the CDDs/CDFs and labeled compounds and the internal standards, a single set of analyses can be used to produce calibration curves for the isotope dilution and internal standard methods. These curves are verified each shift (Section 15.3) by analyzing the calibration verification standard (VER, Table 4). Recalibration is required if any of the calibration verification criteria (Section 15.3) cannot be met.
- 10.8 Data Storage—MS data shall be collected, recorded, and stored.
- 10.8.1 Data acquisition—The signal at each exact m/z shall be collected repetitively throughout the monitoring period and stored on a mass storage device.
- 10.8.2 Response factors and multipoint calibrations—The data system shall be used to record and maintain lists of response factors (response ratios for isotope dilution) and multipoint calibration curves. Computations of relative standard deviation (coefficient of variation) shall be used to test calibration linearity. Statistics on initial performance (Section 9.2) and ongoing performance (Section 15.5) should be computed and maintained, either on the instrument data system, or on a separate computer system.

11.0 Sample Preparation

- 11.1 Sample preparation involves modifying the physical form of the sample so that the CDDs/CDFs can be extracted efficiently. In general, the samples must be in a liquid form or in the form of finely divided solids in order for efficient extraction to take place. Table 10 lists the phases and suggested quantities for extraction of various sample matrices.

For samples known or expected to contain high levels of the CDDs/CDFs, the smallest sample size representative of the entire sample should be used (see Section 17.5).

For all samples, the blank and IPR/OPR aliquots must be processed through the same steps as the sample to check for contamination and losses in the preparation processes.

- 11.1.1 For samples that contain particles, percent solids and particle size are determined using the procedures in Sections 11.2 and 11.3, respectively.
- 11.1.2 Aqueous samples—Because CDDs/CDFs may be bound to suspended particles, the preparation of aqueous samples is dependent on the solids content of the sample.
- 11.1.2.1 Aqueous samples visibly absent particles are prepared per Section 11.4 and extracted directly using the separatory funnel or SPE techniques in Sections 12.1 or 12.2, respectively.

- 11.1.2.2 Aqueous samples containing visible particles and containing one percent suspended solids or less are prepared using the procedure in Section 11.4. After preparation, the sample is extracted directly using the SPE technique in 12.2 or filtered per Section 11.4.3. After filtration, the particles and filter are extracted using the SDS procedure in Section 12.3 and the filtrate is extracted using the separatory funnel procedure in Section 12.1.
- 11.1.2.3 For aqueous samples containing greater than one percent solids, a sample aliquot sufficient to provide 10 g of dry solids is used, as described in Section 11.5.
- 11.1.3 Solid samples are prepared using the procedure described in Section 11.5 followed by extraction via the SDS procedure in Section 12.3.
- 11.1.4 Multiphase samples—The phase(s) containing the CDDs/CDFs is separated from the non-CDD/CDF phase using pressure filtration and centrifugation, as described in Section 11.6. The CDDs/CDFs will be in the organic phase in a multiphase sample in which an organic phase exists.
- 11.1.5 Procedures for grinding, homogenization, and blending of various sample phases are given in Section 11.7.
- 11.1.6 Tissue samples—Preparation procedures for fish and other tissues are given in Section 11.8.

11.2 Determination of Percent Suspended Solids

NOTE: *This aliquot is used for determining the solids content of the sample, not for determination of CDDs/CDFs.*

- 11.2.1 Aqueous liquids and multi-phase samples consisting of mainly an aqueous phase.
- 11.2.1.1 Dessicate and weigh a GF/D filter (Section 6.5.3) to three significant figures.
- 11.2.1.2 Filter 10.0 ±0.02 mL of well-mixed sample through the filter.
- 11.2.1.3 Dry the filter a minimum of 12 hours at 110 ±5°C and cool in a dessicator.
- 11.2.1.4 Calculate percent solids as follows:

$$\% \text{solids} = \frac{\text{weight of sample aliquot after drying (g)} - \text{weight of filter (g)}}{10 \text{ g}} \times 100$$

- 11.2.2 Non-aqueous liquids, solids, semi-solid samples, and multi-phase samples in which the main phase is not aqueous; but not tissues.
- 11.2.2.1 Weigh 5-10 g of sample to three significant figures in a tared beaker.

11.2.2.2 Dry a minimum of 12 hours at $110 \pm 5^\circ\text{C}$, and cool in a dessicator.

11.2.2.3 Calculate percent solids as follows:

$$\% \text{ solids} = \frac{\text{weight of sample aliquot after drying}}{\text{weight of sample aliquot before drying}} \times 100$$

11.3 Determination of Particle Size

11.3.1 Spread the dried sample from Section 11.2.2.2 on a piece of filter paper or aluminum foil in a fume hood or glove box.

11.3.2 Estimate the size of the particles in the sample. If the size of the largest particles is greater than 1 mm, the particle size must be reduced to 1 mm or less prior to extraction using the procedures in Section 11.7.

11.4 Preparation of Aqueous Samples Containing 1% Suspended Solids or Less

11.4.1 Aqueous samples visibly absent particles are prepared per the procedure below and extracted directly using the separatory funnel or SPE techniques in Sections 12.1 or 12.2, respectively. Aqueous samples containing visible particles and one percent suspended solids or less are prepared using the procedure below and extracted using either the SPE technique in Section 12.2 or further prepared using the filtration procedure in Section 11.4.3. The filtration procedure is followed by SDS extraction of the filter and particles (Section 12.3) and separatory funnel extraction of the filtrate (Section 12.1). The SPE procedure is followed by SDS extraction of the filter and disk.

11.4.2 Preparation of sample and QC aliquots

11.4.2.1 Mark the original level of the sample on the sample bottle for reference. Weigh the sample plus bottle to ± 1 g.

11.4.2.2 Spike 1.0 mL of the diluted labeled-compound spiking solution (Section 7.10.3) into the sample bottle. Cap the bottle and mix the sample by careful shaking. Allow the sample to equilibrate for one to two hours, with occasional shaking.

11.4.2.3 For each sample or sample batch (to a maximum of 20 samples) to be extracted during the same 12-hour shift, place two 1.0 L aliquots of reagent water in clean sample bottles or flasks.

11.4.2.4 Spike 1.0 mL of the diluted labeled-compound spiking solution (Section 7.10.3) into both reagent water aliquots. One of these aliquots will serve as the method blank.

11.4.2.5 Spike 1.0 mL of the PAR standard (Section 7.14) into the remaining reagent water aliquot. This aliquot will serve as the OPR (Section 15.5).

- 11.4.2.6 If SPE is to be used, add 5 mL of methanol to the sample, cap and shake the sample to mix thoroughly, and proceed to Section 12.2 for extraction. If SPE is not to be used, and the sample is visibly absent particles, proceed to Section 12.1 for extraction. If SPE is not to be used and the sample contains visible particles, proceed to the following section for filtration of particles.

11.4.3 Filtration of particles

- 11.4.3.1 Assemble a Buchner funnel (Section 6.5.5) on top of a clean filtration flask. Apply vacuum to the flask, and pour the entire contents of the sample bottle through a glass-fiber filter (Section 6.5.6) in the Buchner funnel, swirling the sample remaining in the bottle to suspend any particles.
- 11.4.3.2 Rinse the sample bottle twice with approximately 5 mL portions of reagent water to transfer any remaining particles onto the filter.
- 11.4.3.3 Rinse any particles off the sides of the Buchner funnel with small quantities of reagent water.
- 11.4.3.4 Weigh the empty sample bottle to ± 1 g. Determine the weight of the sample by difference. Save the bottle for further use.
- 11.4.3.5 Extract the filtrate using the separatory funnel procedure in Section 12.1.
- 11.4.3.6 Extract the filter containing the particles using the SDS procedure in Section 12.3.

11.5 Preparation of Samples Containing Greater Than 1% Solids

- 11.5.1 Weigh a well-mixed aliquot of each sample (of the same matrix type) sufficient to provide 10 g of dry solids (based on the solids determination in Section 11.2) into a clean beaker or glass jar.
- 11.5.2 Spike 1.0 mL of the diluted labeled compound spiking solution (Section 7.10.3) into the sample.
- 11.5.3 For each sample or sample batch (to a maximum of 20 samples) to be extracted during the same 12-hour shift, weigh two 10 g aliquots of the appropriate reference matrix (Section 7.6) into clean beakers or glass jars.
- 11.5.4 Spike 1.0 mL of the diluted labeled compound spiking solution (Section 7.10.3) into each reference matrix aliquot. One aliquot will serve as the method blank. Spike 1.0 mL of the PAR standard (Section 7.14) into the other reference matrix aliquot. This aliquot will serve as the OPR (Section 15.5).
- 11.5.5 Stir or tumble and equilibrate the aliquots for one to two hours.

- 11.5.6 Decant excess water. If necessary to remove water, filter the sample through a glass-fiber filter and discard the aqueous liquid.
- 11.5.7 If particles >1mm are present in the sample (as determined in Section 11.3.2), spread the sample on clean aluminum foil in a hood. After the sample is dry, grind to reduce the particle size (Section 11.7).
- 11.5.8 Extract the sample and QC aliquots using the SDS procedure in Section 12.3.
- 11.6 Multiphase Samples
- 11.6.1 Using the percent solids determined in Section 11.2.1 or 11.2.2, determine the volume of sample that will provide 10 g of solids, up to 1 L of sample.
- 11.6.2 Pressure filter the amount of sample determined in Section 11.6.1 through Whatman GF/D glass-fiber filter paper (Section 6.5.3). Pressure filter the blank and OPR aliquots through GF/D papers also. If necessary to separate the phases and/or settle the solids, centrifuge these aliquots prior to filtration.
- 11.6.3 Discard any aqueous phase (if present). Remove any non-aqueous liquid present and reserve the maximum amount filtered from the sample (Section 11.6.1) or 10 g, whichever is less, for combination with the solid phase (Section 12.3.5).
- 11.6.4 If particles >1mm are present in the sample (as determined in Section 11.3.2) and the sample is capable of being dried, spread the sample and QC aliquots on clean aluminum foil in a hood. After the aliquots are dry or if the sample cannot be dried, reduce the particle size using the procedures in Section 11.7 and extract the reduced particles using the SDS procedure in Section 12.3. If particles >1mm are not present, extract the particles and filter in the sample and QC aliquots directly using the SDS procedure in Section 12.3.
- 11.7 Sample grinding, homogenization, or blending—Samples with particle sizes greater than 1 mm (as determined in Section 11.3.2) are subjected to grinding, homogenization, or blending. The method of reducing particle size to less than 1 mm is matrix-dependent. In general, hard particles can be reduced by grinding with a mortar and pestle. Softer particles can be reduced by grinding in a Wiley mill or meat grinder, by homogenization, or in a blender.
- 11.7.1 Each size-reducing preparation procedure on each matrix shall be verified by running the tests in Section 9.2 before the procedure is employed routinely.
- 11.7.2 The grinding, homogenization, or blending procedures shall be carried out in a glove box or fume hood to prevent particles from contaminating the work environment.
- 11.7.3 Grinding—Certain papers and pulps, slurries, and amorphous solids can be ground in a Wiley mill or heavy duty meat grinder. In some cases, reducing the temperature of the sample to freezing or to dry ice or liquid nitrogen temperatures can aid in the grinding process. Grind the sample aliquots from Section 11.5.7 or 11.6.4 in a clean grinder. Do not allow the sample temperature

to exceed 50°C. Grind the blank and reference matrix aliquots using a clean grinder.

11.7.4 Homogenization or blending—Particles that are not ground effectively, or particles greater than 1 mm in size after grinding, can often be reduced in size by high speed homogenization or blending. Homogenize and/or blend the particles or filter from Section 11.5.7 or 11.6.4 for the sample, blank, and OPR aliquots.

11.7.5 Extract the aliquots using the SDS procedure in Section 12.3.

11.8 Fish and Other Tissues—Prior to processing tissue samples, the laboratory must determine the exact tissue to be analyzed. Common requests for analysis of fish tissue include whole fish—skin on, whole fish—skin removed, edible fish fillets (filleted in the field or by the laboratory), specific organs, and other portions. Once the appropriate tissue has been determined, the sample must be homogenized.

11.8.1 Homogenization

11.8.1.1 Samples are homogenized while still frozen, where practical. If the laboratory must dissect the whole fish to obtain the appropriate tissue for analysis, the unused tissues may be rapidly refrozen and stored in a clean glass jar for subsequent use.

11.8.1.2 Each analysis requires 10 g of tissue (wet weight). Therefore, the laboratory should homogenize at least 20 g of tissue to allow for re-extraction of a second aliquot of the same homogenized sample, if re-analysis is required. When whole fish analysis is necessary, the entire fish is homogenized.

11.8.1.3 Homogenize the sample in a tissue homogenizer (Section 6.3.3) or grind in a meat grinder (Section 6.3.4). Cut tissue too large to feed into the grinder into smaller pieces. To assure homogeneity, grind three times.

11.8.1.4 Transfer approximately 10 g (wet weight) of homogenized tissue to a clean, tared, 400-500 mL beaker. For the alternate HCl digestion/extraction, transfer the tissue to a clean, tared 500-600 mL wide-mouth bottle. Record the weight to the nearest 10 mg.

11.8.1.5 Transfer the remaining homogenized tissue to a clean jar with a fluoropolymer-lined lid. Seal the jar and store the tissue at <-10°C. Return any tissue that was not homogenized to its original container and store at <-10°C.

11.8.2 QC aliquots

11.8.2.1 Prepare a method blank by adding approximately 10 g of the oily liquid reference matrix (Section 7.6.4) to a 400-500 mL beaker. For the alternate HCl digestion/extraction, add the reference matrix to a 500-600 mL wide-mouth bottle. Record the weight to the nearest 10 mg.

11.8.2.2 Prepare a precision and recovery aliquot by adding approximately 10 g of the oily liquid reference matrix (Section 7.6.4) to a separate 400-500 mL beaker or wide-mouth bottle, depending on the extraction procedure to be used. Record the weight to the nearest 10 mg. If the initial precision and recovery test is to be performed, use four aliquots; if the ongoing precision and recovery test is to be performed, use a single aliquot.

11.8.3 Spiking

11.8.3.1 Spike 1.0 mL of the labeled compound spiking solution (Section 7.10.3) into the sample, blank, and OPR aliquot.

11.8.3.2 Spike 1.0 mL of the PAR standard (Section 7.14) into the OPR aliquot.

11.8.4 Extract the aliquots using the procedures in Section 12.4.

12.0 Extraction and Concentration

Extraction procedures include separatory funnel (Section 12.1) and solid phase (Section 12.2) for aqueous liquids; Soxhlet/Dean-Stark (Section 12.3) for solids, filters, and SPE disks; and Soxhlet extraction (Section 12.4.1) and HCl digestion (Section 12.4.2) for tissues. Acid/base back-extraction (Section 12.5) is used for initial cleanup of extracts.

Macro-concentration procedures include rotary evaporation (Section 12.6.1), heating mantle (Section 12.6.2), and Kuderna-Danish (K-D) evaporation (Section 12.6.3). Micro-concentration uses nitrogen blowdown (Section 12.7).

12.1 Separatory funnel extraction of filtrates and of aqueous samples visibly absent particles.

12.1.1 Pour the spiked sample (Section 11.4.2.2) or filtrate (Section 11.4.3.5) into a 2 L separatory funnel. Rinse the bottle or flask twice with 5 mL of reagent water and add these rinses to the separatory funnel.

12.1.2 Add 60 mL methylene chloride to the empty sample bottle (Section 12.1.1), seal, and shake 60 seconds to rinse the inner surface. Transfer the solvent to the separatory funnel, and extract the sample by shaking the funnel for two minutes with periodic venting. Allow the organic layer to separate from the aqueous phase for a minimum of 10 minutes. If an emulsion forms and is more than one-third the volume of the solvent layer, employ mechanical techniques to complete the phase separation (see note below). Drain the methylene chloride extract through a solvent-rinsed glass funnel approximately one-half full of granular

anhydrous sodium sulfate (Section 7.2.1) supported on clean glass-fiber paper into a solvent-rinsed concentration device (Section 12.6).

NOTE: *If an emulsion forms, the analyst must employ mechanical techniques to complete the phase separation. The optimum technique depends upon the sample, but may include stirring, filtration through glass wool, use of phase separation paper, centrifugation, use of an ultrasonic bath with ice, addition of NaCl, or other physical methods. Alternatively, solid-phase or other extraction techniques may be used to prevent emulsion formation. Any alternative technique is acceptable so long as the requirements in Section 9 are met.*

Experience with aqueous samples high in dissolved organic materials (e.g., paper mill effluents) has shown that acidification of the sample prior to extraction may reduce the formation of emulsions. Paper industry methods suggest that the addition of up to 400 mL of ethanol to a 1 L effluent sample may also reduce emulsion formation. However, studies by EPA suggest that the effect may be a result of sample dilution, and that the addition of reagent water may serve the same function. Mechanical techniques may still be necessary to complete the phase separation. If either acidification or addition of ethanol is utilized, the laboratory must perform the startup tests described in Section 9.2 using the same techniques.

12.1.3 Extract the water sample two more times with 60 mL portions of methylene chloride. Drain each portion through the sodium sulfate into the concentrator. After the third extraction, rinse the separatory funnel with at least 20 mL of methylene chloride, and drain this rinse through the sodium sulfate into the concentrator. Repeat this rinse at least twice. Set aside the funnel with sodium sulfate if the extract is to be combined with the extract from the particles.

12.1.4 Concentrate the extract using one of the macro-concentration procedures in Section 12.6.

12.1.4.1 If the extract is from a sample visibly absent particles (Section 11.1.2.1), adjust the final volume of the concentrated extract to approximately 10 mL with hexane, transfer to a 250 mL separatory funnel, and back-extract using the procedure in Section 12.5.

12.1.4.2 If the extract is from the aqueous filtrate (Section 11.4.3.5), set aside the concentration apparatus for addition of the SDS extract from the particles (Section 12.3.9.1.2).

12.2 SPE of Samples Containing Less Than 1% Solids (References 19-20)

12.2.1 Disk preparation

12.2.1.1 Place an SPE disk on the base of the filter holder (Figure 4) and wet with toluene. While holding a GMF 150 filter above the SPE disk with tweezers, wet the filter with toluene and lay the filter on the SPE disk, making sure that air is not trapped between the filter and disk. Clamp the filter and SPE disk between the 1 L glass reservoir and the vacuum filtration flask.

- 12.2.1.2 Rinse the sides of the filtration flask with approx 15 mL of toluene using a squeeze bottle or syringe. Apply vacuum momentarily until a few drops appear at the drip tip. Release the vacuum and allow the filter/disk to soak for approx one minute. Apply vacuum and draw all of the toluene through the filter/disk. Repeat the wash step with approx 15 mL of acetone and allow the filter/disk to air dry.
- 12.2.1.3 Re-wet the filter/disk with approximately 15 mL of methanol, allowing the filter/disk to soak for approximately one minute. Pull the methanol through the filter/disk using the vacuum, but retain a layer of methanol approximately 1 mm thick on the filter. Do not allow the disk to go dry from this point until the end of the extraction.
- 12.2.1.4 Rinse the filter/disk with two 50-mL portions of reagent water by adding the water to the reservoir and pulling most through, leaving a layer of water on the surface of the filter.

12.2.2 Extraction

- 12.2.2.1 Pour the spiked sample (Section 11.4.2.2), blank (Section 11.4.2.4), or IPR/OPR aliquot (Section 11.4.2.5) into the reservoir and turn on the vacuum to begin the extraction. Adjust the vacuum to complete the extraction in no less than 10 minutes. For samples containing a high concentration of particles (suspended solids), filtration times may be eight hours or longer.
- 12.2.2.2 Before all of the sample has been pulled through the filter/disk, rinse the sample bottle with approximately 50 mL of reagent water to remove any solids, and pour into the reservoir. Pull through the filter/disk. Use additional reagent water rinses until all visible solids are removed.
- 12.2.2.3 Before all of the sample and rinses have been pulled through the filter/disk, rinse the sides of the reservoir with small portions of reagent water.
- 12.2.2.4 Allow the filter/disk to dry, then remove the filter and disk and place in a glass Petri dish. Extract the filter and disk per Section 12.3.

12.3 SDS Extraction of Samples Containing Particles, and of Filters and/or Disks

- 12.3.1 Charge a clean extraction thimble (Section 6.4.2.2) with 5.0 g of 100/200 mesh silica (Section 7.5.1.1) topped with 100 g of quartz sand (Section 7.3.2).

NOTE: Do not disturb the silica layer throughout the extraction process.

- 12.3.2 Place the thimble in a clean extractor. Place 30-40 mL of toluene in the receiver and 200-250 mL of toluene in the flask.

- 12.3.3 Pre-extract the glassware by heating the flask until the toluene is boiling. When properly adjusted, one to two drops of toluene will fall per second from the condenser tip into the receiver. Extract the apparatus for a minimum of three hours.
- 12.3.4 After pre-extraction, cool and disassemble the apparatus. Rinse the thimble with toluene and allow to air dry.
- 12.3.5 Load the wet sample, filter, and/or disk from Section 11.4.3.6, 11.5.8, 11.6.4, 11.7.3, 11.7.4, or 12.2.2.4 and any nonaqueous liquid from Section 11.6.3 into the thimble and manually mix into the sand layer with a clean metal spatula, carefully breaking up any large lumps of sample.
- 12.3.6 Reassemble the pre-extracted SDS apparatus, and add a fresh charge of toluene to the receiver and reflux flask. Apply power to the heating mantle to begin refluxing. Adjust the reflux rate to match the rate of percolation through the sand and silica beds until water removal lessens the restriction to toluene flow. Frequently check the apparatus for foaming during the first two hours of extraction. If foaming occurs, reduce the reflux rate until foaming subsides.
- 12.3.7 Drain the water from the receiver at one to two hours and eight to nine hours, or sooner if the receiver fills with water. Reflux the sample for a total of 16-24 hours. Cool and disassemble the apparatus. Record the total volume of water collected.
- 12.3.8 Remove the distilling flask. Drain the water from the Dean-Stark receiver and add any toluene in the receiver to the extract in the flask.
- 12.3.9 Concentrate the extract using one of the macro-concentration procedures in Section 12.6 per the following:
- 12.3.9.1 Extracts from the particles in an aqueous sample containing less than 1% solids (Section 11.4.3.6).
 - 12.3.9.1.1 Concentrate the extract to approximately 5 mL using the rotary evaporator or heating mantle procedures in Section 12.6.1 or 12.6.2.
 - 12.3.9.1.2 Quantitatively transfer the extract through the sodium sulfate (Section 12.1.3) into the apparatus that was set aside (Section 12.1.4.2) and reconcentrate to the level of the toluene.
 - 12.3.9.1.3 Adjust to approximately 10 mL with hexane, transfer to a 250 mL separatory funnel, and proceed with back-extraction (Section 12.5).
 - 12.3.9.2 Extracts from particles (Sections 11.5 through 11.6) or from the SPE filter and disk (Section 12.2.2.4)—Concentrate to approximately 10 mL using the rotary evaporator or heating mantle (Section 12.6.1

or 12.6.2), transfer to a 250 mL separatory funnel, and proceed with back-extraction (Section 12.5).

12.4 Extraction of Tissue—Two procedures are provided for tissue extraction.

12.4.1 Soxhlet extraction (Reference 21)

- 12.4.1.1 Add 30-40 g of powdered anhydrous sodium sulfate to each of the beakers (Section 11.8.4) and mix thoroughly. Cover the beakers with aluminum foil and allow to equilibrate for 12-24 hours. Remix prior to extraction to prevent clumping.
- 12.4.1.2 Assemble and pre-extract the Soxhlet apparatus per Sections 12.3.1 through 12.3.4, except use the methylene chloride:hexane (1:1) mixture for the pre-extraction and rinsing and omit the quartz sand. The Dean-Stark moisture trap may also be omitted, if desired.
- 12.4.1.3 Reassemble the pre-extracted Soxhlet apparatus and add a fresh charge of methylene chloride:hexane to the reflux flask.
- 12.4.1.4 Transfer the sample/sodium sulfate mixture (Section 12.4.1.1) to the Soxhlet thimble, and install the thimble in the Soxhlet apparatus.
- 12.4.1.5 Rinse the beaker with several portions of solvent mixture and add to the thimble. Fill the thimble/receiver with solvent. Extract for 18-24 hours.
- 12.4.1.6 After extraction, cool and disassemble the apparatus.
- 12.4.1.7 Quantitatively transfer the extract to a macro-concentration device (Section 12.6), and concentrate to near dryness. Set aside the concentration apparatus for re-use.
- 12.4.1.8 Complete the removal of the solvent using the nitrogen blowdown procedure (Section 12.7) and a water bath temperature of 60°C. Weigh the receiver, record the weight, and return the receiver to the blowdown apparatus, concentrating the residue until a constant weight is obtained.
- 12.4.1.9 Percent lipid determination—The lipid content is determined by extraction of tissue with the same solvent system (methylene chloride:hexane) that was used in EPA's National Dioxin Study (Reference 22) so that lipid contents are consistent with that study.
- 12.4.1.9.1 Redissolve the residue in the receiver in hexane and spike 1.0 mL of the cleanup standard (Section 7.11) into the solution.

12.4.1.9.2 Transfer the residue/hexane to the anthropogenic isolation column (Section 13.7.1) or bottle for the acidified silica gel batch cleanup (Section 13.7.2), retaining the boiling chips in the concentration apparatus. Use several rinses to assure that all material is transferred. If necessary, sonicate or heat the receiver slightly to assure that all material is re-dissolved. Allow the receiver to dry. Weigh the receiver and boiling chips.

12.4.1.9.3 Calculate the lipid content to the nearest three significant figures as follows:

$$\text{Percent lipid} = \frac{\text{Weight of residue (g)}}{\text{Weight of tissue (g)}} \times 100$$

12.4.1.9.4 It is not necessary to determine the lipid content of the blank, IPR, or OPR aliquots.

12.4.2 HCl digestion/extraction and concentration (References 23-26)

12.4.2.1 Add 200 mL of 6 N HCl and 200 mL of methylene chloride:hexane (1:1) to the sample and QC aliquots (Section 11.8.4).

12.4.2.2 Cap and shake each bottle one to three times. Loosen the cap in a hood to vent excess pressure. Shake each bottle for 10-30 seconds and vent.

12.4.2.3 Tightly cap and place on shaker. Adjust the shaker action and speed so that the acid, solvent, and tissue are in constant motion. However, take care to avoid such violent action that the bottle may be dislodged from the shaker. Shake for 12-24 hours.

12.4.2.4 After digestion, remove the bottles from the shaker. Allow the bottles to stand so that the solvent and acid layers separate.

12.4.2.5 Decant the solvent through a glass funnel with glass-fiber filter (Sections 6.5.2 through 6.5.3) containing approximately 10 g of granular anhydrous sodium sulfate (Section 7.2.1) into a macro-concentration apparatus (Section 12.6). Rinse the contents of the bottle with two 25 mL portions of hexane and pour through the sodium sulfate into the apparatus.

12.4.2.6 Concentrate the solvent to near dryness using a macro-concentration procedure (Section 12.6).

12.4.2.7 Complete the removal of the solvent using the nitrogen blowdown apparatus (Section 12.7) and a water bath temperature of 60°C. Weigh the receiver, record the weight, and return the receiver to the blowdown apparatus, concentrating the residue until a constant weight is obtained.

- 12.4.2.8 Percent lipid determination—The lipid content is determined in the same solvent system [methylene chloride:hexane (1:1)] that was used in EPA's National Dioxin Study (Reference 22) so that lipid contents are consistent with that study.
- 12.4.2.8.1 Redissolve the residue in the receiver in hexane and spike 1.0 mL of the cleanup standard (Section 7.11) into the solution.
- 12.4.2.8.2 Transfer the residue/hexane to the narrow-mouth 100-200 mL bottle retaining the boiling chips in the receiver. Use several rinses to assure that all material is transferred, to a maximum hexane volume of approximately 70 mL. Allow the receiver to dry. Weigh the receiver and boiling chips.
- 12.4.2.8.3 Calculate the percent lipid per Section 12.4.1.9.3. It is not necessary to determine the lipid content of the blank, IPR, or OPR aliquots.
- 12.4.2.9 Clean up the extract per Section 13.7.3.

12.5 Back-Extraction with Base and Acid

- 12.5.1 Spike 1.0 mL of the cleanup standard (Section 7.11) into the separatory funnels containing the sample and QC extracts from Section 12.1.4.1, 12.3.9.1.3, or 12.3.9.2.
- 12.5.2 Partition the extract against 50 mL of potassium hydroxide solution (Section 7.1.1). Shake for two minutes with periodic venting into a hood. Remove and discard the aqueous layer. Repeat the base washing until no color is visible in the aqueous layer, to a maximum of four washings. Minimize contact time between the extract and the base to prevent degradation of the CDDs/CDFs. Stronger potassium hydroxide solutions may be employed for back-extraction, provided that the laboratory meets the specifications for labeled compound recovery and demonstrates acceptable performance using the procedure in Section 9.2.
- 12.5.3 Partition the extract against 50 mL of sodium chloride solution (Section 7.1.4) in the same way as with base. Discard the aqueous layer.
- 12.5.4 Partition the extract against 50 mL of sulfuric acid (Section 7.1.2) in the same way as with base. Repeat the acid washing until no color is visible in the aqueous layer, to a maximum of four washings.
- 12.5.5 Repeat the partitioning against sodium chloride solution and discard the aqueous layer.
- 12.5.6 Pour each extract through a drying column containing 7-10 cm of granular anhydrous sodium sulfate (Section 7.2.1). Rinse the separatory funnel with 30-50 mL of solvent, and pour through the drying column. Collect each extract in a round-bottom flask. Re-concentrate the sample and QC aliquots per Sections 12.6 through 12.7, and clean up the samples and QC aliquots per Section 13.

12.6 Macro-Concentration—Extracts in toluene are concentrated using a rotary evaporator or a heating mantle; extracts in methylene chloride or hexane are concentrated using a rotary evaporator, heating mantle, or Kuderna-Danish apparatus.

12.6.1 Rotary evaporation—Concentrate the extracts in separate round-bottom flasks.

12.6.1.1 Assemble the rotary evaporator according to manufacturer's instructions, and warm the water bath to 45°C. On a daily basis, preclean the rotary evaporator by concentrating 100 mL of clean extraction solvent through the system. Archive both the concentrated solvent and the solvent in the catch flask for a contamination check if necessary. Between samples, three 2-3 mL aliquots of solvent should be rinsed down the feed tube into a waste beaker.

12.6.1.2 Attach the round-bottom flask containing the sample extract to the rotary evaporator. Slowly apply vacuum to the system, and begin rotating the sample flask.

12.6.1.3 Lower the flask into the water bath, and adjust the speed of rotation and the temperature as required to complete concentration in 15-20 minutes. At the proper rate of concentration, the flow of solvent into the receiving flask will be steady, but no bumping or visible boiling of the extract will occur.

NOTE: If the rate of concentration is too fast, analyte loss may occur.

12.6.1.4 When the liquid in the concentration flask has reached an apparent volume of approximately 2 mL, remove the flask from the water bath and stop the rotation. Slowly and carefully admit air into the system. Be sure not to open the valve so quickly that the sample is blown out of the flask. Rinse the feed tube with approximately 2 mL of solvent.

12.6.1.5 Proceed to Section 12.6.4 for preparation for back-extraction or micro-concentration and solvent exchange.

12.6.2 Heating mantle—Concentrate the extracts in separate round-bottom flasks.

12.6.2.1 Add one or two clean boiling chips to the round-bottom flask, and attach a three-ball macro Snyder column. Prewet the column by adding approximately 1 mL of solvent through the top. Place the round-bottom flask in a heating mantle, and apply heat as required to complete the concentration in 15-20 minutes. At the proper rate of distillation, the balls of the column will actively chatter, but the chambers will not flood.

12.6.2.2 When the liquid has reached an apparent volume of approximately 10 mL, remove the round-bottom flask from the heating mantle and allow the solvent to drain and cool for at least 10 minutes.

Remove the Snyder column and rinse the glass joint into the receiver with small portions of solvent.

12.6.2.3 Proceed to Section 12.6.4 for preparation for back-extraction or micro-concentration and solvent exchange.

12.6.3 Kuderna-Danish (K-D)—Concentrate the extracts in separate 500 mL K-D flasks equipped with 10 mL concentrator tubes. The K-D technique is used for solvents such as methylene chloride and hexane. Toluene is difficult to concentrate using the K-D technique unless a water bath fed by a steam generator is used.

12.6.3.1 Add one to two clean boiling chips to the receiver. Attach a three-ball macro Snyder column. Prewet the column by adding approximately 1 mL of solvent through the top. Place the K-D apparatus in a hot water bath so that the entire lower rounded surface of the flask is bathed with steam.

12.6.3.2 Adjust the vertical position of the apparatus and the water temperature as required to complete the concentration in 15-20 minutes. At the proper rate of distillation, the balls of the column will actively chatter but the chambers will not flood.

12.6.3.3 When the liquid has reached an apparent volume of 1 mL, remove the K-D apparatus from the bath and allow the solvent to drain and cool for at least 10 minutes. Remove the Snyder column and rinse the flask and its lower joint into the concentrator tube with 1-2 mL of solvent. A 5 mL syringe is recommended for this operation.

12.6.3.4 Remove the three-ball Snyder column, add a fresh boiling chip, and attach a two-ball micro Snyder column to the concentrator tube. Prewet the column by adding approximately 0.5 mL of solvent through the top. Place the apparatus in the hot water bath.

12.6.3.5 Adjust the vertical position and the water temperature as required to complete the concentration in 5-10 minutes. At the proper rate of distillation, the balls of the column will actively chatter but the chambers will not flood.

12.6.3.6 When the liquid reaches an apparent volume of 0.5 mL, remove the apparatus from the water bath and allow to drain and cool for at least 10 minutes.

12.6.3.7 Proceed to 12.6.4 for preparation for back-extraction or micro-concentration and solvent exchange.

12.6.4 Preparation for back-extraction or micro-concentration and solvent exchange.

12.6.4.1 For back-extraction (Section 12.5), transfer the extract to a 250 mL separatory funnel. Rinse the concentration vessel with small

portions of hexane, adjust the hexane volume in the separatory funnel to 10-20 mL, and proceed to back-extraction (Section 12.5).

- 12.6.4.2 For determination of the weight of residue in the extract, or for clean-up procedures other than back-extraction, transfer the extract to a blowdown vial using two to three rinses of solvent. Proceed with micro-concentration and solvent exchange (Section 12.7).

12.7 Micro-Concentration and Solvent Exchange

12.7.1 Extracts to be subjected to GPC or HPLC cleanup are exchanged into methylene chloride. Extracts to be cleaned up using silica gel, alumina, carbon, and/or Florisil are exchanged into hexane.

12.7.2 Transfer the vial containing the sample extract to a nitrogen blowdown device. Adjust the flow of nitrogen so that the surface of the solvent is just visibly disturbed.

NOTE: *A large vortex in the solvent may cause analyte loss.*

12.7.3 Lower the vial into a 45°C water bath and continue concentrating.

12.7.3.1 If the extract is to be concentrated to dryness for weight determination (Sections 12.4.1.8, 12.4.2.7, and 13.7.1.4), blow dry until a constant weight is obtained.

12.7.3.2 If the extract is to be concentrated for injection into the GC/MS or the solvent is to be exchanged for extract cleanup, proceed as follows:

12.7.4 When the volume of the liquid is approximately 100 µL, add 2-3 mL of the desired solvent (methylene chloride for GPC and HPLC, or hexane for the other cleanups) and continue concentration to approximately 100 µL. Repeat the addition of solvent and concentrate once more.

12.7.5 If the extract is to be cleaned up by GPC, adjust the volume of the extract to 5.0 mL with methylene chloride. If the extract is to be cleaned up by HPLC, further concentrate the extract to 30 µL. Proceed with GPC or HPLC cleanup (Section 13.2 or 13.6, respectively).

12.7.6 If the extract is to be cleaned up by column chromatography (alumina, silica gel, Carbopak/Celite, or Florisil), bring the final volume to 1.0 mL with hexane. Proceed with column cleanups (Sections 13.3 through 13.5 and 13.8).

12.7.7 If the extract is to be concentrated for injection into the GC/MS (Section 14), quantitatively transfer the extract to a 0.3 mL conical vial for final concentration, rinsing the larger vial with hexane and adding the rinse to the conical vial. Reduce the volume to approximately 100 µL. Add 10 µL of nonane to the vial, and evaporate the solvent to the level of the nonane. Seal the vial and label with the sample number. Store in the dark at room temperature until ready for

GC/MS analysis. If GC/MS analysis will not be performed on the same day, store the vial at $<-10^{\circ}\text{C}$.

13.0 Extract Cleanup

13.1 Cleanup may not be necessary for relatively clean samples (e.g., treated effluents, groundwater, drinking water). If particular circumstances require the use of a cleanup procedure, the analyst may use any or all of the procedures below or any other appropriate procedure. Before using a cleanup procedure, the analyst must demonstrate that the requirements of Section 9.2 can be met using the cleanup procedure. If only 2,3,7,8-TCDD and 2,3,7,8-TCDF are to be determined, the cleanup procedures may be optimized for isolation of these two compounds.

13.1.1 Gel permeation chromatography (Section 13.2) removes high molecular weight interferences that cause GC column performance to degrade. It should be used for all soil and sediment extracts and may be used for water extracts that are expected to contain high molecular weight organic compounds (e.g., polymeric materials, humic acids).

13.1.2 Acid, neutral, and basic silica gel (Section 13.3), alumina (Section 13.4), and Florisil (Section 13.8) are used to remove nonpolar and polar interferences. Alumina and Florisil are used to remove chlorodiphenyl ethers.

13.1.3 Caropak/Celite (Section 13.5) is used to remove nonpolar interferences.

13.1.4 HPLC (Section 13.6) is used to provide specificity for the 2,3,7,8-substituted and other CDD and CDF isomers.

13.1.5 The anthropogenic isolation column (Section 13.7.1), acidified silica gel batch adsorption procedure (Section 13.7.2), and sulfuric acid and base back-extraction (Section 13.7.3) are used for removal of lipids from tissue samples.

13.2 Gel Permeation Chromatography (GPC)

13.2.1 Column packing

13.2.1.1 Place 70-75 g of SX-3 Bio-beads (Section 6.7.1.1) in a 400-500 mL beaker.

13.2.1.2 Cover the beads with methylene chloride and allow to swell overnight (a minimum of 12 hours).

13.2.1.3 Transfer the swelled beads to the column (Section 6.7.1.1) and pump solvent through the column, from bottom to top, at 4.5-5.5 mL/minute prior to connecting the column to the detector.

13.2.1.4 After purging the column with solvent for one to two hours, adjust the column head pressure to 7-10 psig and purge for four to five hours to remove air. Maintain a head pressure of 7-10 psig. Connect the column to the detector (Section 6.7.1.4).

13.2.2 Column calibration

- 13.2.2.1 Load 5 mL of the calibration solution (Section 7.4) into the sample loop.
- 13.2.2.2 Inject the calibration solution and record the signal from the detector. The elution pattern will be corn oil, bis(2-ethyl hexyl)phthalate, pentachlorophenol, perylene, and sulfur.
- 13.2.2.3 Set the "dump time" to allow >85% removal of the corn oil and >85% collection of the phthalate.
- 13.2.2.4 Set the "collect time" to the peak minimum between perylene and sulfur.
- 13.2.2.5 Verify the calibration with the calibration solution after every 20 extracts. Calibration is verified if the recovery of the pentachlorophenol is greater than 85%. If calibration is not verified, the system shall be recalibrated using the calibration solution, and the previous 20 samples shall be re-extracted and cleaned up using the calibrated GPC system.

13.2.3 Extract cleanup—GPC requires that the column not be overloaded. The column specified in this method is designed to handle a maximum of 0.5 g of high molecular weight material in a 5 mL extract. If the extract is known or expected to contain more than 0.5 g, the extract is split into aliquots for GPC, and the aliquots are combined after elution from the column. The residue content of the extract may be obtained gravimetrically by evaporating the solvent from a 50 μ L aliquot.

- 13.2.3.1 Filter the extract or load through the filter holder (Section 6.7.1.3) to remove the particles. Load the 5.0 mL extract onto the column.
- 13.2.3.2 Elute the extract using the calibration data determined in Section 13.2.2. Collect the eluate in a clean 400-500 mL beaker.
- 13.2.3.3 Rinse the sample loading tube thoroughly with methylene chloride between extracts to prepare for the next sample.
- 13.2.3.4 If a particularly dirty extract is encountered, a 5.0 mL methylene chloride blank shall be run through the system to check for carry-over.
- 13.2.3.5 Concentrate the eluate per Sections 12.6 and 12.7 for further cleanup or injection into the GC/MS.

13.3 Silica Gel Cleanup

- 13.3.1 Place a glass-wool plug in a 15 mm ID chromatography column (Section 6.7.4.2). Pack the column bottom to top with: 1 g silica gel (Section 7.5.1.1), 4 g basic silica gel (Section 7.5.1.3), 1 g silica gel, 8 g acid silica gel (Section 7.5.1.2), 2 g silica gel,

and 4 g granular anhydrous sodium sulfate (Section 7.2.1). Tap the column to settle the adsorbents.

- 13.3.2 Pre-elute the column with 50-100 mL of hexane. Close the stopcock when the hexane is within 1 mm of the sodium sulfate. Discard the eluate. Check the column for channeling. If channeling is present, discard the column and prepare another.
- 13.3.3 Apply the concentrated extract to the column. Open the stopcock until the extract is within 1 mm of the sodium sulfate.
- 13.3.4 Rinse the receiver twice with 1 mL portions of hexane, and apply separately to the column. Elute the CDDs/CDFs with 100 mL hexane, and collect the eluate.
- 13.3.5 Concentrate the eluate per Sections 12.6 and 12.7 for further cleanup or injection into the HPLC or GC/MS.
- 13.3.6 For extracts of samples known to contain large quantities of other organic compounds (such as paper mill effluents), it may be advisable to increase the capacity of the silica gel column. This may be accomplished by increasing the strengths of the acid and basic silica gels. The acid silica gel (Section 7.5.1.2) may be increased in strength to as much as 44% w/w (7.9 g sulfuric acid added to 10 g silica gel). The basic silica gel (Section 7.5.1.3) may be increased in strength to as much as 33% w/w (50 mL 1N NaOH added to 100 g silica gel), or the potassium silicate (Section 7.5.1.4) may be used.

NOTE: *The use of stronger acid silica gel (44% w/w) may lead to charring of organic compounds in some extracts. The charred material may retain some of the analytes and lead to lower recoveries of CDDs/CDFs. Increasing the strengths of the acid and basic silica gel may also require different volumes of hexane than those specified above to elute the analytes off the column. Therefore, the performance of the method after such modifications must be verified by the procedure in Section 9.2.*

13.4 Alumina Cleanup

- 13.4.1 Place a glass-wool plug in a 15 mm ID chromatography column (Section 6.7.4.2).
- 13.4.2 If using acid alumina, pack the column by adding 6 g acid alumina (Section 7.5.2.1). If using basic alumina, substitute 6 g basic alumina (Section 7.5.2.2). Tap the column to settle the adsorbents.
- 13.4.3 Pre-elute the column with 50-100 mL of hexane. Close the stopcock when the hexane is within 1 mm of the alumina.
- 13.4.4 Discard the eluate. Check the column for channeling. If channeling is present, discard the column and prepare another.
- 13.4.5 Apply the concentrated extract to the column. Open the stopcock until the extract is within 1 mm of the alumina.

- 13.4.6 Rinse the receiver twice with 1 mL portions of hexane and apply separately to the column. Elute the interfering compounds with 100 mL hexane and discard the eluate.
- 13.4.7 The choice of eluting solvents will depend on the choice of alumina (acid or basic) made in Section 13.4.2.
- 13.4.7.1 If using acid alumina, elute the CDDs/CDFs from the column with 20 mL methylene chloride:hexane (20:80 v/v). Collect the eluate.
- 13.4.7.2 If using basic alumina, elute the CDDs/CDFs from the column with 20 mL methylene chloride:hexane (50:50 v/v). Collect the eluate.
- 13.4.8 Concentrate the eluate per Sections 12.6 and 12.7 for further cleanup or injection into the HPLC or GC/MS.
- 13.5 Carbon Column
- 13.5.1 Cut both ends from a 10 mL disposable serological pipet (Section 6.7.3.2) to produce a 10 cm column. Fire-polish both ends and flare both ends if desired. Insert a glass-wool plug at one end, and pack the column with 0.55 g of Carbowax/Celite (Section 7.5.3.3) to form an adsorbent bed approximately 2 cm long. Insert a glass-wool plug on top of the bed to hold the adsorbent in place.
- 13.5.2 Pre-elute the column with 5 mL of toluene followed by 2 mL of methylene chloride:methanol:toluene (15:4:1 v/v), 1 mL of methylene chloride:cyclohexane (1:1 v/v), and 5 mL of hexane. If the flow rate of eluate exceeds 0.5 mL/minute, discard the column.
- 13.5.3 When the solvent is within 1 mm of the column packing, apply the sample extract to the column. Rinse the sample container twice with 1 mL portions of hexane and apply separately to the column. Apply 2 mL of hexane to complete the transfer.
- 13.5.4 Elute the interfering compounds with two 3 mL portions of hexane, 2 mL of methylene chloride:cyclohexane (1:1 v/v), and 2 mL of methylene chloride:methanol:toluene (15:4:1 v/v). Discard the eluate.
- 13.5.5 Invert the column, and elute the CDDs/CDFs with 20 mL of toluene. If carbon particles are present in the eluate, filter through glass-fiber filter paper.
- 13.5.6 Concentrate the eluate per Sections 12.6 and 12.7 for further cleanup or injection into the HPLC or GC/MS.
- 13.6 HPLC (Reference 6)
- 13.6.1 Column calibration

- 13.6.1.1 Prepare a calibration standard containing the 2,3,7,8-substituted isomers and/or other isomers of interest at a concentration of approximately 500 pg/ μ L in methylene chloride.
- 13.6.1.2 Inject 30 μ L of the calibration solution into the HPLC and record the signal from the detector. Collect the eluant for reuse. The elution order will be the tetra- through octa-isomers.
- 13.6.1.3 Establish the collection time for the tetra-isomers and for the other isomers of interest. Following calibration, flush the injection system with copious quantities of methylene chloride, including a minimum of five 50 μ L injections while the detector is monitored, to ensure that residual CDDs/CDFs are removed from the system.
- 13.6.1.4 Verify the calibration with the calibration solution after every 20 extracts. Calibration is verified if the recovery of the CDDs/CDFs from the calibration standard (Section 13.6.1.1) is 75-125% compared to the calibration (Section 13.6.1.2). If calibration is not verified, the system shall be recalibrated using the calibration solution, and the previous 20 samples shall be re-extracted and cleaned up using the calibrated system.
- 13.6.2 Extract cleanup—HPLC requires that the column not be overloaded. The column specified in this method is designed to handle a maximum of 30 μ L of extract. If the extract cannot be concentrated to less than 30 μ L, it is split into fractions and the fractions are combined after elution from the column.
- 13.6.2.1 Rinse the sides of the vial twice with 30 μ L of methylene chloride and reduce to 30 μ L with the evaporation apparatus (Section 12.7).
- 13.6.2.2 Inject the 30 μ L extract into the HPLC.
- 13.6.2.3 Elute the extract using the calibration data determined in Section 13.6.1. Collect the fraction(s) in a clean 20 mL concentrator tube containing 5 mL of hexane:acetone (1:1 v/v).
- 13.6.2.4 If an extract containing greater than 100 ng/mL of total CDD or CDF is encountered, a 30 μ L methylene chloride blank shall be run through the system to check for carry-over.
- 13.6.2.5 Concentrate the eluate per Section 12.7 for injection into the GC/MS.
- 13.7 Cleanup of Tissue Lipids—Lipids are removed from the Soxhlet extract using either the anthropogenic isolation column (Section 13.7.1) or acidified silica gel (Section 13.7.2), or are removed from the HCl digested extract using sulfuric acid and base back-extraction (Section 13.7.3).
- 13.7.1 Anthropogenic isolation column (References 22 and 27)—Used for removal of lipids from the Soxhlet/SDS extraction (Section 12.4.1).

-
- 13.7.1.1 Prepare the column as given in Section 7.5.4.
- 13.7.1.2 Pre-elute the column with 100 mL of hexane. Drain the hexane layer to the top of the column, but do not expose the sodium sulfate.
- 13.7.1.3 Load the sample and rinses (Section 12.4.1.9.2) onto the column by draining each portion to the top of the bed. Elute the CDDs/CDFs from the column into the apparatus used for concentration (Section 12.4.1.7) using 200 mL of hexane.
- 13.7.1.4 Concentrate the cleaned up extract (Sections 12.6 through 12.7) to constant weight per Section 12.7.3.1. If more than 500 mg of material remains, repeat the cleanup using a fresh anthropogenic isolation column.
- 13.7.1.5 Redissolve the extract in a solvent suitable for the additional cleanups to be used (Sections 13.2 through 13.6 and 13.8).
- 13.7.1.6 Spike 1.0 mL of the cleanup standard (Section 7.11) into the residue/solvent.
- 13.7.1.7 Clean up the extract using the procedures in Sections 13.2 through 13.6 and 13.8. Alumina (Section 13.4) or Florisil (Section 13.8) and carbon (Section 13.5) are recommended as minimum additional cleanup steps.
- 13.7.1.8 Following cleanup, concentrate the extract to 10 μ L as described in Section 12.7 and proceed with the analysis in Section 14.
- 13.7.2 Acidified silica gel (Reference 28)—Procedure alternate to the anthropogenic isolation column (Section 13.7.1) that is used for removal of lipids from the Soxhlet/SDS extraction (Section 12.4.1).
- 13.7.2.1 Adjust the volume of hexane in the bottle (Section 12.4.1.9.2) to approximately 200 mL.
- 13.7.2.2 Spike 1.0 mL of the cleanup standard (Section 7.11) into the residue/solvent.
- 13.7.2.3 Drop the stirring bar into the bottle, place the bottle on the stirring plate, and begin stirring.
- 13.7.2.4 Add 30-100 g of acid silica gel (Section 7.5.1.2) to the bottle while stirring, keeping the silica gel in motion. Stir for two to three hours.

NOTE: 30 grams of silica gel should be adequate for most samples and will minimize contamination from this source.

- 13.7.2.5 After stirring, pour the extract through approximately 10 g of granular anhydrous sodium sulfate (Section 7.2.1) contained in a funnel with glass-fiber filter into a macro concentration device (Section 12.6). Rinse the bottle and sodium sulfate with hexane to complete the transfer.
- 13.7.2.6 Concentrate the extract per Sections 12.6 through 12.7 and clean up the extract using the procedures in Sections 13.2 through 13.6 and 13.8. Alumina (Section 13.4) or Florisil (Section 13.8) and carbon (Section 13.5) are recommended as minimum additional cleanup steps.
- 13.7.3 Sulfuric acid and base back-extraction—Used with HCl digested extracts (Section 12.4.2).
- 13.7.3.1 Spike 1.0 mL of the cleanup standard (Section 7.11) into the residue/solvent (Section 12.4.2.8.2).
- 13.7.3.2 Add 10 mL of concentrated sulfuric acid to the bottle. Immediately cap and shake one to three times. Loosen cap in a hood to vent excess pressure. Cap and shake the bottle so that the residue/solvent is exposed to the acid for a total time of approximately 45 seconds.
- 13.7.3.3 Decant the hexane into a 250 mL separatory funnel making sure that no acid is transferred. Complete the quantitative transfer with several hexane rinses.
- 13.7.3.4 Back extract the solvent/residue with 50 mL of potassium hydroxide solution per Section 12.5.2, followed by two reagent water rinses.
- 13.7.3.5 Drain the extract through a filter funnel containing approximately 10 g of granular anhydrous sodium sulfate in a glass-fiber filter into a macro concentration device (Section 12.6).
- 13.7.3.6 Concentrate the cleaned up extract to a volume suitable for the additional cleanups given in Sections 13.2 through 13.6 and 13.8. Gel permeation chromatography (Section 13.2), alumina (Section 13.4) or Florisil (Section 13.8), and Carbopak/Celite (Section 13.5) are recommended as minimum additional cleanup steps.
- 13.7.3.7 Following cleanup, concentrate the extract to 10 μ L as described in Section 12.7 and proceed with analysis per Section 14.
- 13.8 Florisil Cleanup (Reference 29)
- 13.8.1 Pre-elute the activated Florisil column (Section 7.5.3) with 10 mL of methylene chloride followed by 10 mL of hexane:methylene chloride (98:2 v/v) and discard the solvents.

- 13.8.2 When the solvent is within 1 mm of the packing, apply the sample extract (in hexane) to the column. Rinse the sample container twice with 1 mL portions of hexane and apply to the column.
- 13.8.3 Elute the interfering compounds with 20 mL of hexane:methylene chloride (98:2) and discard the eluate.
- 13.8.4 Elute the CDDs/CDFs with 35 mL of methylene chloride and collect the eluate. Concentrate the eluate per Sections 12.6 through 12.7 for further cleanup or for injection into the HPLC or GC/MS.

14.0 HRGC/HRMS Analysis

- 14.1 Establish the operating conditions given in Section 10.1.
- 14.2 Add 10 μL of the appropriate internal standard solution (Section 7.12) to the sample extract immediately prior to injection to minimize the possibility of loss by evaporation, adsorption, or reaction. If an extract is to be reanalyzed and evaporation has occurred, do not add more instrument internal standard solution. Rather, bring the extract back to its previous volume (e.g., 19 μL) with pure nonane only (18 μL if 2 μL injections are used).
- 14.3 Inject 1.0 μL or 2.0 μL of the concentrated extract containing the internal standard solution, using on-column or splitless injection. The volume injected must be identical to the volume used for calibration (Section 10). Start the GC column initial isothermal hold upon injection. Start MS data collection after the solvent peak elutes. Stop data collection after the OCDD and OCDF have eluted. If only 2,3,7,8-TCDD and 2,3,7,8-TCDF are to be determined, stop data collection after elution of these compounds. Return the column to the initial temperature for analysis of the next extract or standard.

15.0 System and Laboratory Performance

- 15.1 At the beginning of each 12-hour shift during which analyses are performed, GC/MS system performance and calibration are verified for all CDDs/CDFs and labeled compounds. For these tests, analysis of the CS3 calibration verification (VER) standard (Section 7.13 and Table 4) and the isomer specificity test standards (Section 7.15 and Table 5) shall be used to verify all performance criteria. Adjustment and/or recalibration (Section 10) shall be performed until all performance criteria are met. Only after all performance criteria are met may samples, blanks, IPRs, and OPRs be analyzed.
- 15.2 MS Resolution—A static resolving power of at least 10,000 (10% valley definition) must be demonstrated at the appropriate m/z before any analysis is performed. Static resolving power checks must be performed at the beginning and at the end of each 12-hour shift according to procedures in Section 10.1.2. Corrective actions must be implemented whenever the resolving power does not meet the requirement.
- 15.3 Calibration Verification
- 15.3.1 Inject the VER standard using the procedure in Section 14.

- 15.3.2 The m/z abundance ratios for all CDDs/CDFs shall be within the limits in Table 9; otherwise, the mass spectrometer shall be adjusted until the m/z abundance ratios fall within the limits specified, and the verification test shall be repeated. If the adjustment alters the resolution of the mass spectrometer, resolution shall be verified (Section 10.1.2) prior to repeat of the verification test.
- 15.3.3 The peaks representing each CDD/CDF and labeled compound in the VER standard must be present with S/N of at least 10; otherwise, the mass spectrometer shall be adjusted and the verification test repeated.
- 15.3.4 Compute the concentration of each CDD/CDF compound by isotope dilution (Section 10.5) for those compounds that have labeled analogs (Table 1). Compute the concentration of the labeled compounds by the internal standard method (Section 10.6). These concentrations are computed based on the calibration data in Section 10.
- 15.3.5 For each compound, compare the concentration with the calibration verification limit in Table 6. If only 2,3,7,8-TCDD and 2,3,7,8-TCDF are to be determined, compare the concentration to the limit in Table 6a. If all compounds meet the acceptance criteria, calibration has been verified and analysis of standards and sample extracts may proceed. If, however, any compound fails its respective limit, the measurement system is not performing properly for that compound. In this event, prepare a fresh calibration standard or correct the problem causing the failure and repeat the resolution (Section 15.2) and verification (Section 15.3) tests, or recalibrate (Section 10).
- 15.4 Retention Times and GC Resolution
- 15.4.1 Retention times
- 15.4.1.1 Absolute—The absolute retention times of the $^{13}\text{C}_{12}$ -1,2,3,4-TCDD and $^{13}\text{C}_{12}$ -1,2,3,7,8,9-HxCDD GCMS internal standards in the verification test (Section 15.3) shall be within ± 15 seconds of the retention times obtained during calibration (Sections 10.2.1 and 10.2.4).
- 15.4.1.2 Relative—The relative retention times of CDDs/CDFs and labeled compounds in the verification test (Section 15.3) shall be within the limits given in Table 2.
- 15.4.2 GC resolution
- 15.4.2.1 Inject the isomer specificity standards (Section 7.15) on their respective columns.
- 15.4.2.2 The valley height between 2,3,7,8-TCDD and the other tetra-dioxin isomers at m/z 319.8965, and between 2,3,7,8-TCDF and the other tetra-furan isomers at m/z 303.9016 shall not exceed 25% on their respective columns (Figures 6 and 7).

- 15.4.3 If the absolute retention time of any compound is not within the limits specified or if the 2,3,7,8-isomers are not resolved, the GC is not performing properly. In this event, adjust the GC and repeat the verification test (Section 15.3) or recalibrate (Section 10), or replace the GC column and either verify calibration or recalibrate.
- 15.5 Ongoing Precision and Recovery
- 15.5.1 Analyze the extract of the ongoing precision and recovery (OPR) aliquot (Section 11.4.2.5, 11.5.4, 11.6.2, 11.7.4, or 11.8.3.2) prior to analysis of samples from the same batch.
- 15.5.2 Compute the concentration of each CDD/CDF by isotope dilution for those compounds that have labeled analogs (Section 10.5). Compute the concentration of 1,2,3,7,8,9-HxCDD, OCDF, and each labeled compound by the internal standard method (Section 10.6).
- 15.5.3 For each CDD/CDF and labeled compound, compare the concentration to the OPR limits given in Table 6. If only 2,3,7,8-TCDD and 2,3,7,8-TCDF are to be determined, compare the concentration to the limits in Table 6a. If all compounds meet the acceptance criteria, system performance is acceptable and analysis of blanks and samples may proceed. If, however, any individual concentration falls outside of the range given, the extraction/concentration processes are not being performed properly for that compound. In this event, correct the problem, re-prepare, extract, and clean up the sample batch and repeat the ongoing precision and recovery test (Section 15.5).
- 15.5.4 Add results that pass the specifications in Section 15.5.3 to initial and previous ongoing data for each compound in each matrix. Update QC charts to form a graphic representation of continued laboratory performance. Develop a statement of laboratory accuracy for each CDD/CDF in each matrix type by calculating the average percent recovery (R) and the standard deviation of percent recovery (S_R). Express the accuracy as a recovery interval from $R-2S_R$ to $R+2S_R$. For example, if $R = 95\%$ and $S_R = 5\%$, the accuracy is 85-105%.
- 15.6 Blank—Analyze the method blank extracted with each sample batch immediately following analysis of the OPR aliquot to demonstrate freedom from contamination and freedom from carryover from the OPR analysis. The results of the analysis of the blank must meet the specifications in Section 9.5.2 before sample analyses may proceed.

16.0 Qualitative Determination

A CDD, CDF, or labeled compound is identified in a standard, blank, or sample when all of the criteria in Sections 16.1 through 16.4 are met.

- 16.1 The signals for the two exact m/z 's in Table 8 must be present and must maximize within the same two seconds.
- 16.2 The signal-to-noise ratio (S/N) for the GC peak at each exact m/z must be greater than or equal to 2.5 for each CDD or CDF detected in a sample extract, and greater than or equal to 10 for all CDDs/CDFs in the calibration standard (Sections 10.2.3 and 15.3.3).

- 16.3 The ratio of the integrated areas of the two exact m/z's specified in Table 8 must be within the limit in Table 9, or within $\pm 10\%$ of the ratio in the midpoint (CS3) calibration or calibration verification (VER), whichever is most recent.
- 16.4 The relative retention time of the peak for a 2,3,7,8-substituted CDD or CDF must be within the limit in Table 2. The retention time of peaks representing non-2,3,7,8-substituted CDDs/CDFs must be within the retention time windows established in Section 10.3.
- 16.5 Confirmatory Analysis—Isomer specificity for 2,3,7,8-TCDF cannot be achieved on the DB-5 column. Therefore, any sample in which 2,3,7,8-TCDF is identified by analysis on a DB-5 column must have a confirmatory analysis performed on a DB-225, SP-2330, or equivalent GC column. The operating conditions in Section 10.1.1 may be adjusted to optimize the analysis on the second GC column, but the GC/MS must meet the mass resolution and calibration specifications in Section 10.
- 16.6 If the criteria for identification in Sections 16.1 through 16.5 are not met, the CDD or CDF has not been identified and the results may not be reported for regulatory compliance purposes. If interferences preclude identification, a new aliquot of sample must be extracted, further cleaned up, and analyzed.

17.0 Quantitative Determination

- 17.1 Isotope Dilution Quantitation—By adding a known amount of a labeled compound to every sample prior to extraction, correction for recovery of the CDD/CDF can be made because the CDD/CDF and its labeled analog exhibit similar effects upon extraction, concentration, and gas chromatography. Relative response (RR) values are used in conjunction with the initial calibration data described in Section 10.5 to determine concentrations directly, so long as labeled compound spiking levels are constant, using the following equation:

$$C_{ex} \text{ (ng/mL)} = \frac{(A_n + A_n) C_i}{(A_i + A_i) RR}$$

where,

C_{ex} = The concentration of the CDD/CDF in the extract, and the other terms are as defined in Section 10.5.2.

- 17.1.1 Because of a potential interference, the labeled analog of OCDF is not added to the sample. Therefore, OCDF is quantitated against labeled OCDD. As a result, the concentration of OCDF is corrected for the recovery of the labeled OCDD. In instances where OCDD and OCDF behave differently during sample extraction, concentration, and cleanup procedures, this may decrease the accuracy of the OCDF results. However, given the low toxicity of this compound relative to the other dioxins and furans, the potential decrease in accuracy is not considered significant.

17.1.2 Because $^{13}\text{C}_{12}$ -1,2,3,7,8,9-HxCDD is used as an instrument internal standard (i.e., not added before extraction of the sample), it cannot be used to quantitate the 1,2,3,7,8,9-HxCDD by strict isotope dilution procedures. Therefore, 1,2,3,7,8,9-HxCDD is quantitated using the averaged response of the labeled analogs of the other two 2,3,7,8-substituted HxCDD's: 1,2,3,4,7,8-HxCDD and 1,2,3,6,7,8-HxCDD. As a result, the concentration of 1,2,3,7,8,9-HxCDD is corrected for the average recovery of the other two HxCDD's.

17.1.3 Any peaks representing non-2,3,7,8-substituted CDDs/CDFs are quantitated using an average of the response factors from all of the labeled 2,3,7,8-isomers at the same level of chlorination.

17.2 Internal Standard Quantitation and Labeled Compound Recovery

17.2.1 Compute the concentrations of 1,2,3,7,8,9-HxCDD, OCDF, the ^{13}C -labeled analogs and the ^{37}Cl -labeled cleanup standard in the extract using the response factors determined from the initial calibration data (Section 10.6) and the following equation:

$$C_{ex} \text{ (ng/mL)} = \frac{(A_s + A_{i_s}) C_{is}}{(A_{i_s} + A_{i_s}) RF}$$

where,

C_{ex} = The concentration of the CDD/CDF in the extract, and the other terms are as defined in Section 10.6.1.

NOTE: *There is only one m/z for the ^{37}Cl -labeled standard.*

17.2.2 Using the concentration in the extract determined above, compute the percent recovery of the ^{13}C -labeled compounds and the ^{37}Cl -labeled cleanup standard using the following equation:

$$\text{Recovery (\%)} = \frac{\text{Concentration found } (\mu\text{g/mL})}{\text{Concentration spiked } (\mu\text{g/mL})} \times 100$$

17.3 The concentration of a CDD/CDF in the solid phase of the sample is computed using the concentration of the compound in the extract and the weight of the solids (Section 11.5.1), as follows:

$$\text{Concentration in solid (ng/kg)} = \frac{(C_{ex} \times V_{ex})}{W_s}$$

where,

C_{ex} = The concentration of the compound in the extract.

V_{ex} = The extract volume in mL.

W_s = The sample weight (dry weight) in kg.

17.4 The concentration of a CDD/CDF in the aqueous phase of the sample is computed using the concentration of the compound in the extract and the volume of water extracted (Section 11.4 or 11.5), as follows:

$$\text{Concentration in aqueous phase (pg/L)} = \frac{(C_{ex} \times V_{ex})}{V_s}$$

where,

C_{ex} = The concentration of the compound in the extract.

V_{ex} = The extract volume in mL.

V_s = The sample volume in liters.

17.5 If the SICP area at either quantitation m/z for any compound exceeds the calibration range of the system, a smaller sample aliquot is extracted.

17.5.1 For aqueous samples containing 1% solids or less, dilute 100 mL, 10 mL, etc., of sample to 1 L with reagent water and re-prepare, extract, clean up, and analyze per Sections 11 through 14.

17.5.2 For samples containing greater than 1% solids, extract an amount of sample equal to 1/10, 1/100, etc., of the amount used in Section 11.5.1. Re-prepare, extract, clean up, and analyze per Sections 11 through 14.

17.5.3 If a smaller sample size will not be representative of the entire sample, dilute the sample extract by a factor of 10, adjust the concentration of the instrument internal standard to 100 pg/ μ L in the extract, and analyze an aliquot of this diluted extract by the internal standard method.

17.6 Results are reported to three significant figures for the CDDs/CDFs and labeled compounds found in all standards, blanks, and samples.

17.6.1 Reporting units and levels

17.6.1.1 Aqueous samples—Report results in pg/L (parts-per-quadrillion).

17.6.1.2 Samples containing greater than 1% solids (soils, sediments, filter cake, compost)—Report results in ng/kg based on the dry weight of the sample. Report the percent solids so that the result may be corrected.

17.6.1.3 Tissues—Report results in ng/kg of wet tissue, not on the basis of the lipid content of the sample. Report the percent lipid content, so that the data user can calculate the concentration on a lipid basis if desired.

17.6.1.4 Reporting level

- 17.6.1.4.1 Standards (VER, IPR, OPR) and samples—Report results at or above the minimum level (Table 2). Report results below the minimum level as not detected or as required by the regulatory authority.
- 17.6.1.4.2 Blanks—Report results above one-third the ML.
- 17.6.2 Results for CDDs/CDFs in samples that have been diluted are reported at the least dilute level at which the areas at the quantitation m/z's are within the calibration range (Section 17.5).
- 17.6.3 For CDDs/CDFs having a labeled analog, results are reported at the least dilute level at which the area at the quantitation m/z is within the calibration range (Section 17.5) and the labeled compound recovery is within the normal range for the method (Section 9.3 and Tables 6, 6a, 7, and 7a).
- 17.6.4 Additionally, if requested, the total concentration of all isomers in an individual level of chlorination (i.e., total TCDD, total TCDF, total Paced, etc.) may be reported by summing the concentrations of all isomers identified in that level of chlorination, including both 2,3,7,8-substituted and non-2,3,7,8-substituted isomers.

18.0 Analysis of Complex Samples

- 18.1 Some samples may contain high levels (>10 ng/L; >1000 ng/kg) of the compounds of interest, interfering compounds, and/or polymeric materials. Some extracts will not concentrate to 10 µL (Section 12.7); others may overload the GC column and/or mass spectrometer.
- 18.2 Analyze a smaller aliquot of the sample (Section 17.5) when the extract will not concentrate to 10 µL after all cleanup procedures have been exhausted.
- 18.3 Chlorodiphenyl Ethers—If chromatographic peaks are detected at the retention time of any CDDs/CDFs in any of the m/z channels being monitored for the chlorodiphenyl ethers (Table 8), cleanup procedures must be employed until these interferences are removed. Alumina (Section 13.4) and Florisil (Section 13.8) are recommended for removal of chlorodiphenyl ethers.
- 18.4 Recovery of Labeled Compounds—In most samples, recoveries of the labeled compounds will be similar to those from reagent water or from the alternate matrix (Section 7.6).
- 18.4.1 If the recovery of any of the labeled compounds is outside of the normal range (Table 7), a diluted sample shall be analyzed (Section 17.5).
- 18.4.2 If the recovery of any of the labeled compounds in the diluted sample is outside of normal range, the calibration verification standard (Section 7.13) shall be analyzed and calibration verified (Section 15.3).
- 18.4.3 If the calibration cannot be verified, a new calibration must be performed and the original sample extract reanalyzed.

18.4.4 If the calibration is verified and the diluted sample does not meet the limits for labeled compound recovery, the method does not apply to the sample being analyzed and the result may not be reported for regulatory compliance purposes. In this case, alternate extraction and cleanup procedures in this method must be employed to resolve the interference. If all cleanup procedures in this method have been employed and labeled compound recovery remains outside of the normal range, extraction and/or cleanup procedures that are beyond this scope of this method will be required to analyze these samples.

19.0 Pollution Prevention

- 19.1 The solvents used in this method pose little threat to the environment when managed properly. The solvent evaporation techniques used in this method are amenable to solvent recovery, and it is recommended that the laboratory recover solvents wherever feasible.
- 19.2 Standards should be prepared in volumes consistent with laboratory use to minimize disposal of standards.

20.0 Waste Management

- 20.1 It is the laboratory's responsibility to comply with all federal, state, and local regulations governing waste management, particularly the hazardous waste identification rules and land disposal restrictions, and to protect the air, water, and land by minimizing and controlling all releases from fume hoods and bench operations. Compliance is also required with any sewage discharge permits and regulations.
- 20.2 Samples containing HCl to pH <2 are hazardous and must be neutralized before being poured down a drain or must be handled as hazardous waste.
- 20.3 The CDDs/CDFs decompose above 800°C. Low-level waste such as absorbent paper, tissues, animal remains, and plastic gloves may be burned in an appropriate incinerator. Gross quantities (milligrams) should be packaged securely and disposed of through commercial or governmental channels that are capable of handling extremely toxic wastes.
- 20.4 Liquid or soluble waste should be dissolved in methanol or ethanol and irradiated with ultraviolet light with a wavelength shorter than 290 nm for several days. Use F40 BL or equivalent lamps. Analyze liquid wastes, and dispose of the solutions when the CDDs/CDFs can no longer be detected.
- 20.5 For further information on waste management, consult "The Waste Management Manual for Laboratory Personnel" and "Less is Better—Laboratory Chemical Management for Waste Reduction," available from the American Chemical Society's Department of Government Relations and Science Policy, 1155 16th Street N.W., Washington, D.C. 20036.

21.0 Method Performance

Method performance was validated and performance specifications were developed using data from EPA's international interlaboratory validation study (References 30-31) and the

EPA/paper industry Long-Term Variability Study of discharges from the pulp and paper industry (58 FR 66078).

22.0 References

1. Tondeur, Yves. "Method 8290: Analytical Procedures and Quality Assurance for Multimedia Analysis of Polychlorinated Dibenzo-*p*-dioxins and Dibenzofurans by High Resolution Gas Chromatography/High Resolution Mass Spectrometry," USEPA EMSL, Las Vegas, Nevada, June 1987.
2. "Measurement of 2,3,7,8-Tetrachlorinated Dibenzo-*p*-dioxin (TCDD) and 2,3,7,8-Tetrachlorinated Dibenzofuran (TCDF) in Pulp, Sludges, Process Samples and Wastewaters from Pulp and Paper Mills," Wright State University, Dayton, OH 45435, June 1988.
3. "NCASI Procedures for the Preparation and Isomer Specific Analysis of Pulp and Paper Industry Samples for 2,3,7,8-TCDD and 2,3,7,8-TCDF," National Council of the Paper Industry for Air and Stream Improvement Inc., 260 Madison Avenue, New York, NY 10016, Technical Bulletin No. 551, Pre-Release Copy, July 1988.
4. "Analytical Procedures and Quality Assurance Plan for the Determination of PCDD/PCDF in Fish," USEPA, Environmental Research Laboratory, 6201 Congdon Boulevard, Duluth, MN 55804, April 1988.
5. Tondeur, Yves. "Proposed GC/MS Methodology for the Analysis of PCDDs and PCDFs in Special Analytical Services Samples," Triangle Laboratories, Inc., 801-10 Capitola Dr, Research Triangle Park, NC 27713, January 1988; updated by personal communication September 1988.
6. Lamparski, L.L. and Nestruck, T.J. "Determination of Tetra-, Hexa-, Hepta-, and Octachlorodibenzo-*p*-dioxin Isomers in Particulate Samples at Parts per Trillion Levels," *Analytical Chemistry*, 52: 2045-2054, 1980.
7. Lamparski, L.L. and Nestruck, T.J. "Novel Extraction Device for the Determination of Chlorinated Dibenzo-*p*-dioxins (PCDDs) and Dibenzofurans (PCDFs) in Matrices Containing Water," *Chemosphere*, 19:27-31, 1989.
8. Patterson, D.G., et. al. "Control of Interferences in the Analysis of Human Adipose Tissue for 2,3,7,8-Tetrachlorodibenzo-*p*-dioxin," *Environmental Toxicological Chemistry*, 5:355-360, 1986.
9. Stanley, John S. and Sack, Thomas M. "Protocol for the Analysis of 2,3,7,8-Tetrachlorodibenzo-*p*-dioxin by High Resolution Gas Chromatography/High Resolution Mass Spectrometry," USEPA EMSL, Las Vegas, Nevada 89114, EPA 600/4-86-004, January 1986.
10. "Working with Carcinogens," Department of Health, Education, & Welfare, Public Health Service, Centers for Disease Control, NIOSH, Publication 77-206, August 1977, NTIS PB-277256.
11. "OSHA Safety and Health Standards, General Industry," OSHA 2206, 29 CFR 1910.
12. "Safety in Academic Chemistry Laboratories," ACS Committee on Chemical Safety, 1979.

13. "Standard Methods for the Examination of Water and Wastewater," 18th edition and later revisions, American Public Health Association, 1015 15th St, N.W., Washington, DC 20005, 1-35: Section 1090 (Safety), 1992.
14. "Method 613—2,3,7,8-Tetrachlorodibenzo-*p*-dioxin," 40 *CFR* 136 (49 *FR* 43234), October 26, 1984, Section 4.1.
15. Provost, L.P. and Elder, R.S. "Interpretation of Percent Recovery Data," *American Laboratory*, 15: 56-83, 1983.
16. "Standard Practice for Sampling Water," ASTM Annual Book of Standards, ASTM, 1916 Race Street, Philadelphia, PA 19103-1187, 1980.
17. "Methods 330.4 and 330.5 for Total Residual Chlorine," USEPA, EMSL, Cincinnati, OH 45268, EPA 600/4-79-020, March 1979.
18. "Handbook of Analytical Quality Control in Water and Wastewater Laboratories," USEPA EMSL, Cincinnati, OH 45268, EPA-600/4-79-019, March 1979.
19. Williams, Rick. Letter to Bill Telliard, June 4, 1993, available from the EPA Sample Control Center operated by DynCorp Viar, Inc., 300 N Lee St, Alexandria, VA 22314, 703-519-1140.
20. Barkowski, Sarah. Fax to Sue Price, August 6, 1992, available from the EPA Sample Control Center operated by DynCorp Viar, Inc., 300 N Lee St, Alexandria VA 22314, 703-519-1140.
21. "Analysis of Multi-media, Multi-concentration Samples for Dioxins and Furans, PCDD/PCDF Analyses Data Package", Narrative for Episode 4419, MRI Project No. 3091-A, op.cit. February 12, 1993, Available from the EPA Sample Control Center operated by DynCorp Viar Inc, 300 N Lee St, Alexandria, VA 22314 (703-519-1140).
22. "Analytical Procedures and Quality Assurance Plan for the Determination of PCDD/PCDF in Fish", U.S. Environmental Protection Agency, Environmental Research Laboratory, Duluth, MN 55804, EPA/600/3-90/022, March 1990.
23. Afghan, B.K., Carron, J., Goulden, P.D., Lawrence, J., Leger, D., Onuska, F., Sherry, J., and Wilkenson, R.J., "Recent Advances in Ultratrace Analysis of Dioxins and Related Halogenated Hydrocarbons", *Can J. Chem.*, 65: 1086-1097, 1987.
24. Sherry, J.P. and Tse, H. "A Procedure for the Determination of Polychlorinated Dibenzop-dioxins in Fish", *Chemosphere*, 20: 865-872, 1990.
25. "Preliminary Fish Tissue Study", Results of Episode 4419, available from the EPA Sample Control Center operated by DynCorp Viar, Inc., 300 N Lee St, Alexandria, VA 22314, 703-519-1140.
26. Nestruck, Terry L. DOW Chemical Co., personal communication with D.R. Rushneck, April 8, 1993. Details available from the U.S. Environmental Protection Agency Sample Control Center operated by DynCorp Viar Inc, 300 N Lee St, Alexandria, VA 22314, 703-519-1140.

27. Barnstadt, Michael. "Big Fish Column", Triangle Laboratories of RTP, Inc., SOP 129-90, 27 March 27, 1992.
28. "Determination of Polychlorinated Dibenzo-*p*-Dioxins (PCDD) and Dibenzofurans (PCDF) in Environmental Samples Using EPA Method 1613", Chemical Sciences Department, Midwest Research Institute, 425 Volker Boulevard, Kansas City, MO 44110-2299, Standard Operating Procedure No. CS-153, January 15, 1992.
29. Ryan, John J. Raymonde Lizotte and William H. Newsome, *J. Chromatog.* 303 (1984) 351-360.
30. Telliard, William A., McCarty, Harry B., and Riddick, Lynn S. "Results of the Interlaboratory Validation Study of USEPA Method 1613 for the Analysis of Tetra-through Octachlorinated Dioxins and Furans by Isotope Dilution GC/MS," *Chemosphere*, 27, 41-46 (1993).
31. "Results of the International Interlaboratory Validation Study of USEPA Method 1613", October 1994, available from the EPA Sample Control Center operated by DynCorp Viar, Inc., 300 N Lee St, Alexandria, VA 22314, 703-519-1140.

23.0 Tables and Figures

TABLE 1. CHLORINATED DIBENZO-*P*-DIOXINS AND FURANS DETERMINED BY ISOTOPE DILUTION AND INTERNAL STANDARD HIGH RESOLUTION GAS CHROMATOGRAPHY (HRGC)/HIGH RESOLUTION MASS SPECTROMETRY (HRMS)

CDDs/CDFs ¹	CAS Registry	Labeled analog	CAS Registry
2,3,7,8-TCDD	1746-01-6	¹³ C ₁₂ -2,3,7,8-TCDD ³⁷ Cl ₄ -2,3,7,8-TCDD	76523-40-5 85508-50-5
Total TCDD	41903-57-5	—	—
2,3,7,8-TCDF	51207-31-9	¹³ C ₁₂ -2,3,7,8-TCDF	89059-46-1
Total-TCDF	55722-27-5	—	—
1,2,3,7,8-PeCDD	40321-76-4	¹³ C ₁₂ -1,2,3,7,8-PeCDD	109719-79-1
Total-PeCDD	36088-22-9	—	—
1,2,3,7,8-PeCDF	57117-41-6	¹³ C ₁₂ -1,2,3,7,8-PeCDF	109719-77-9
2,3,4,7,8-PeCDF	57117-31-4	¹³ C ₁₂ -2,3,4,7,8-PeCDF	116843-02-8
Total-PeCDF	30402-15-4	—	—
1,2,3,4,7,8-HxCDD	39227-28-6	¹³ C ₁₂ -1,2,3,4,7,8-HxCDD	109719-80-4
1,2,3,6,7,8-HxCDD	57653-85-7	¹³ C ₁₂ -1,2,3,6,7,8-HxCDD	109719-81-5
1,2,3,7,8,9-HxCDD	19408-74-3	¹³ C ₁₂ -1,2,3,7,8,9-HxCDD	109719-82-6
Total-HxCDD	34465-46-8	—	—
1,2,3,4,7,8-HxCDF	70648-26-9	¹³ C ₁₂ -1,2,3,4,7,8-HxCDF	114423-98-2
1,2,3,6,7,8-HxCDF	57117-44-9	¹³ C ₁₂ -1,2,3,6,7,8-HxCDF	116843-03-9
1,2,3,7,8,9-HxCDF	72918-21-9	¹³ C ₁₂ -1,2,3,7,8,9-HxCDF	116843-04-0
2,3,4,6,7,8-HxCDF	60851-34-5	¹³ C ₁₂ -2,3,4,6,7,8-HxCDF	116843-05-1
Total-HxCDF	55684-94-1	—	—
1,2,3,4,6,7,8-HpCDD	35822-46-9	¹³ C ₁₂ -1,2,3,4,6,7,8-HpCDD	109719-83-7
Total-HpCDD	37871-00-4	—	—
1,2,3,4,6,7,8-HpCDF	67562-39-4	¹³ C ₁₂ -1,2,3,4,6,7,8-HpCDF	109719-84-8
1,2,3,4,7,8,9-HpCDF	55673-89-7	¹³ C ₁₂ -1,2,3,4,7,8,9-HpCDF	109719-94-0
Total-HpCDF	38998-75-3	—	—
OCDD	3268-87-9	¹³ C ₁₂ -OCDD	114423-97-1
OCDF	39001-02-0	not used	—

¹ Chlorinated dibenzo-*p*-dioxins and chlorinated dibenzofurans

TCDD = Tetrachlorodibenzo-*p*-dioxin
 PeCDD = Pentachlorodibenzo-*p*-dioxin
 HxCDD = Hexachlorodibenzo-*p*-dioxin
 HpCDD = Heptachlorodibenzo-*p*-dioxin
 OCDD = Octachlorodibenzo-*p*-dioxin

TCDF = Tetrachlorodibenzofuran
 PeCDF = Pentachlorodibenzofuran
 HxCDF = Hexachlorodibenzofuran
 HpCDF = Heptachlorodibenzofuran
 OCDF = Octachlorodibenzofuran

TABLE 2. RETENTION TIME REFERENCES, QUANTITATION REFERENCES, RELATIVE RETENTION TIMES, AND MINIMUM LEVELS FOR CDDS AND CDFS

CDD/CDF	Retention time and quantitation reference	Relative retention time	Minimum level ¹		
			Water (pg/L; ppq)	Solid (ng/kg; ppt)	Extract (pg/μL; ppb)
<i>Compounds using ¹³C₁₂-1,2,3,4-TCDD as the injection internal standard</i>					
2,3,7,8-TCDF	¹³ C ₁₂ -2,3,7,8-TCDF	0.999–1.003	10	1	0.5
2,3,7,8-TCDD	¹³ C ₁₂ -2,3,7,8-TCDD	0.999–1.002	10	1	0.5
1,2,3,7,8-PeCDF	¹³ C ₁₂ -1,2,3,7,8-PeCDF	0.999–1.002	50	5	2.5
2,3,4,7,8-PeCDF	¹³ C ₁₂ -2,3,4,7,8-PeCDF	0.999–1.002	50	5	2.5
1,2,3,7,8-PeCDD	¹³ C ₁₂ -1,2,3,7,8-PeCDD	0.999–1.002	50	5	2.5
¹³ C ₁₂ -2,3,7,8-TCDF	¹³ C ₁₂ -1,2,3,4-TCDD	0.923–1.103			
¹³ C ₁₂ -2,3,7,8-TCDD	¹³ C ₁₂ -1,2,3,4-TCDD	0.976–1.043			
³⁷ Cl ₄ -2,3,7,8-TCDD	¹³ C ₁₂ -1,2,3,4-TCDD	0.989–1.052			
¹³ C ₁₂ -1,2,3,7,8-PeCDF	¹³ C ₁₂ -1,2,3,4-TCDD	1.000–1.425			
¹³ C ₁₂ -2,3,4,7,8-PeCDF	¹³ C ₁₂ -1,2,3,4-TCDD	1.011–1.526			
¹³ C ₁₂ -1,2,3,7,8-PeCDD	¹³ C ₁₂ -1,2,3,4-TCDD	1.000–1.567			
<i>Compounds using ¹³C₁₂-1,2,3,7,8,9-HxCDD as the injection internal standard</i>					
1,2,3,4,7,8-HxCDF	¹³ C ₁₂ -1,2,3,4,7,8-HxCDF	0.999–1.001	50	5	2.5
1,2,3,6,7,8-HxCDF	¹³ C ₁₂ -1,2,3,6,7,8-HxCDF	0.997–1.005	50	5	2.5
1,2,3,7,8,9-HxCDF	¹³ C ₁₂ -1,2,3,7,8,9-HxCDF	0.999–1.001	50	5	2.5
2,3,4,6,7,8-HxCDF	¹³ C ₁₂ -2,3,4,6,7,8-HxCDF	0.999–1.001	50	5	2.5
1,2,3,4,7,8-HxCDD	¹³ C ₁₂ -1,2,3,4,7,8-HxCDD	0.999–1.001	50	5	2.5
1,2,3,6,7,8-HxCDD	¹³ C ₁₂ -1,2,3,6,7,8-HxCDD	0.998–1.004	50	5	2.5
1,2,3,7,8,9-HxCDD	— ²	1.000–1.019	50	5	2.5
1,2,3,4,6,7,8-HpCDF	¹³ C ₁₂ -1,2,3,4,6,7,8-HpCDF	0.999–1.001	50	5	2.5
1,2,3,4,7,8,9-HpCDF	¹³ C ₁₂ -1,2,3,4,7,8,9-HpCDF	0.999–1.001	50	5	2.5
1,2,3,4,6,7,8-HpCDD	¹³ C ₁₂ -1,2,3,4,6,7,8-HpCDD	0.999–1.001	50	5	2.5
OCDF	¹³ C ₁₂ -OCDD	0.999–1.008	100	10	5.0
OCDD	¹³ C ₁₂ -OCDD	0.999–1.001	100	10	5.0
¹³ C ₁₂ -1,2,3,4,7,8-HxCDF	¹³ C ₁₂ -1,2,3,7,8,9-HxCDD	0.944–0.970			
¹³ C ₁₂ -1,2,3,6,7,8-HxCDF	¹³ C ₁₂ -1,2,3,7,8,9-HxCDD	0.949–0.975			
¹³ C ₁₂ -1,2,3,7,8,9-HxCDF	¹³ C ₁₂ -1,2,3,7,8,9-HxCDD	0.977–1.047			
¹³ C ₁₂ -2,3,4,6,7,8-HxCDF	¹³ C ₁₂ -1,2,3,7,8,9-HxCDD	0.959–1.021			
¹³ C ₁₂ -1,2,3,4,7,8-HxCDD	¹³ C ₁₂ -1,2,3,7,8,9-HxCDD	0.977–1.000			
¹³ C ₁₂ -1,2,3,6,7,8-HxCDD	¹³ C ₁₂ -1,2,3,7,8,9-HxCDD	0.981–1.003			
¹³ C ₁₂ -1,2,3,4,6,7,8-HpCDF	¹³ C ₁₂ -1,2,3,7,8,9-HxCDD	1.043–1.085			

TABLE 2. RETENTION TIME REFERENCES, QUANTITATION REFERENCES, RELATIVE RETENTION TIMES, AND MINIMUM LEVELS FOR CDDS AND CDFS

CDD/CDF	Retention time and quantitation reference	Relative retention time	Minimum level ¹		
			Water (pg/L; ppq)	Solid (ng/kg; ppt)	Extract (pg/μL; ppb)
¹³ C ₁₂ -1,2,3,4,7,8,9-HpCDF	¹³ C ₁₂ -1,2,3,7,8,9-HxCDD	1.057–1.151			
¹³ C ₁₂ -1,2,3,4,6,7,8-HpCDD	¹³ C ₁₂ -1,2,3,7,8,9-HxCDD	1.086–1.110			
¹³ C ₁₂ -OCDD	¹³ C ₁₂ -1,2,3,7,8,9-HxCDD	1.032–1.311			

¹The Minimum Level (ML) for each analyte is defined as the level at which the entire analytical system must give a recognizable signal and acceptable calibration point. It is equivalent to the concentration of the lowest calibration standard, assuming that all method-specified sample weights, volumes, and cleanup procedures have been employed.

²The retention time reference for 1,2,3,7,8,9-HxCDD is ¹³C₁₂-1,2,3,6,7,8-HxCDD, and 1,2,3,7,8,9-HxCDD is quantified using the averaged responses for ¹³C₁₂-1,2,3,4,7,8-HxCDD and ¹³C₁₂-1,2,3,6,7,8-HxCDD.

TABLE 3. CONCENTRATION OF STOCK AND SPIKING SOLUTIONS CONTAINING CDDS/CDFS AND LABELED COMPOUNDS

CDD/CDF	Labeled Compound Stock Solution ¹ (ng/mL)	Labeled Compound Spiking Solution ² (ng/mL)	PAR Stock Solution ³ (ng/mL)	PAR Spiking Solution ⁴ (ng/mL)
2,3,7,8-TCDD	—	—	40	0.8
2,3,7,8-TCDF	—	—	40	0.8
1,2,3,7,8-PeCDD	—	—	200	4
1,2,3,7,8-PeCDF	—	—	200	4
2,3,4,7,8-PeCDF	—	—	200	4
1,2,3,4,7,8-HxCDD	—	—	200	4
1,2,3,6,7,8-HxCDD	—	—	200	4
1,2,3,7,8,9-HxCDD	—	—	200	4
1,2,3,4,7,8-HxCDF	—	—	200	4
1,2,3,6,7,8-HxCDF	—	—	200	4
1,2,3,7,8,9-HxCDF	—	—	200	4
2,3,4,6,7,8-HxCDF	—	—	200	4
1,2,3,4,6,7,8-HpCDD	—	—	200	4
1,2,3,4,6,7,8-HpCDF	—	—	200	4
1,2,3,4,7,8,9-HpCDF	—	—	200	4
OCDD	—	—	400	8
OCDF	—	—	400	8
¹³ C ₁₂ -2,3,7,8-TCDD	100	2	—	—
¹³ C ₁₂ -2,3,7,8-TCDF	100	2	—	—
¹³ C ₁₂ -1,2,3,7,8-PeCDD	100	2	—	—
¹³ C ₁₂ -1,2,3,7,8-PeCDF	100	2	—	—
¹³ C ₁₂ -2,3,4,7,8-PeCDF	100	2	—	—
¹³ C ₁₂ -1,2,3,4,7,8-HxCDD	100	2	—	—
¹³ C ₁₂ -1,2,3,6,7,8-HxCDD	100	2	—	—
¹³ C ₁₂ -1,2,3,4,7,8-HxCDF	100	2	—	—
¹³ C ₁₂ -1,2,3,6,7,8-HxCDF	100	2	—	—
¹³ C ₁₂ -1,2,3,7,8,9-HxCDF	100	2	—	—
¹³ C ₁₂ -2,3,4,6,7,8-HxCDF	100	2	—	—
¹³ C ₁₂ -1,2,3,4,6,7,8-HpCDD	100	2	—	—
¹³ C ₁₂ -1,2,3,4,6,7,8-HpCDF	100	2	—	—
¹³ C ₁₂ -1,2,3,4,7,8,9-HpCDF	100	2	—	—
¹³ C ₁₂ -OCDD	200	4	—	—

TABLE 3. CONCENTRATION OF STOCK AND SPIKING SOLUTIONS CONTAINING CDDS/CDFS AND LABELED COMPOUNDS

CDD/CDF	Labeled Compound Stock Solution ¹ (ng/mL)	Labeled Compound Spiking Solution ² (ng/mL)	PAR Stock Solution ³ (ng/mL)	PAR Spiking Solution ⁴ (ng/mL)
	Concentration (ng/mL)			
<i>Cleanup Standard</i> ⁵				
³⁷ Cl ₄ -2,3,7,8-TCDD	0.8			
<i>Internal Standards</i> ⁶				
¹³ C ₁₂ -1,2,3,4-TCDD	200			
¹³ C ₁₂ -1,2,3,7,8,9-HxCDD	200			

¹ Section 7.10—prepared in nonane and diluted to prepare spiking solution.

² Section 7.10.3—prepared in acetone from stock solution daily.

³ Section 7.9—prepared in nonane and diluted to prepare spiking solution.

⁴ Section 7.14—prepared in acetone from stock solution daily.

⁵ Section 7.11—prepared in nonane and added to extract prior to cleanup.

⁶ Section 7.12—prepared in nonane and added to the concentrated extract immediately prior to injection into the GC (Section 14.2).

TABLE 4. CONCENTRATION OF CDDs/CDFs IN CALIBRATION AND CALIBRATION VERIFICATION SOLUTIONS ¹ (section 15.3)

	CDD/CDF	CS2 (ng/mL)	CS3 (ng/mL)	CS4 (ng/mL)	CS5 (ng/mL)
2,3,7,8-TCDD	0.5	2	10	40	200
2,3,7,8-TCDF	0.5	2	10	40	200
1,2,3,7,8-PeCDD	2.5	10	50	200	1000
1,2,3,7,8-PeCDF	2.5	10	50	200	1000
2,3,4,7,8-PeCDF	2.5	10	50	200	1000
1,2,3,4,7,8-HxCDD	2.5	10	50	200	1000
1,2,3,6,7,8-HxCDD	2.5	10	50	200	1000
1,2,3,7,8,9-HxCDD	2.5	10	50	200	1000
1,2,3,4,7,8-HxCDF	2.5	10	50	200	1000
1,2,3,6,7,8-HxCDF	2.5	10	50	200	1000
1,2,3,7,8,9-HxCDF	2.5	10	50	200	1000
2,3,4,6,7,8-HxCDF	2.5	10	50	200	1000
1,2,3,4,6,7,8-HpCDD	2.5	10	50	200	1000
1,2,3,4,6,7,8-HpCDF	2.5	10	50	200	1000
1,2,3,4,7,8,9-HpCDF	2.5	10	50	200	1000
OCDD	5.0	20	100	400	2000
OCDF	5.0	20	100	400	2000
¹³ C ₁₂ -2,3,7,8-TCDD	100	100	100	100	100
¹³ C ₁₂ -2,3,7,8-TCDF	100	100	100	100	100
¹³ C ₁₂ -1,2,3,7,8-PeCDD	100	100	100	100	100
¹³ C ₁₂ -PeCDF	100	100	100	100	100
¹³ C ₁₂ -2,3,4,7,8-PeCDF	100	100	100	100	100
¹³ C ₁₂ -1,2,3,4,7,8-HxCDD	100	100	100	100	100
¹³ C ₁₂ -1,2,3,6,7,8-HxCDD	100	100	100	100	100
¹³ C ₁₂ -1,2,3,4,7,8-HxCDF	100	100	100	100	100
¹³ C ₁₂ -1,2,3,6,7,8-HxCDF	100	100	100	100	100
¹³ C ₁₂ -1,2,3,7,8,9-HxCDF	100	100	100	100	100
¹³ C ₁₂ -1,2,3,4,6,7,8-HpCDD	100	100	100	100	100
¹³ C ₁₂ -1,2,3,4,6,7,8-HpCDF	100	100	100	100	100
¹³ C ₁₂ -1,2,3,4,7,8,9-HpCDF	100	100	100	100	100
¹³ C ₁₂ -OCDD	200	200	200	200	200
<i>Cleanup Standard</i>					
³⁷ Cl ₄ -2,3,7,8-TCDD	0.5	2	10	40	200
<i>Internal Standards</i>					
¹³ C ₁₂ -1,2,3,4-TCDD	100	100	100	100	100
¹³ C ₁₂ -1,2,3,7,8,9-HxCDD	100	100	100	100	100

TABLE 5. GC RETENTION TIME WINDOW DEFINING SOLUTION AND ISOMER SPECIFICITY TEST STANDARD (SECTION 7.15)

DB-5 Column GC Retention-Time Window Defining Solution		
CDD/CDF	First Eluted	Last Eluted
TCDF	1,3,6,8-	1,2,8,9-
TCDD	1,3,6,8-	1,2,8,9-
PeCDF	1,3,4,6,8-	1,2,3,8,9-
PeCDD	1,2,4,7,9-	1,2,3,8,9-
HxCDF	1,2,3,4,6,8-	1,2,3,4,8,9-
HxCDD	1,2,4,6,7,9-	1,2,3,4,6,7-
HpCDF	1,2,3,4,6,7,8-	1,2,3,4,7,8,9-
HpCDD	1,2,3,4,6,7,9-	1,2,3,4,6,7,8-

DB-5 Column TCDD Specificity Test Standard

1,2,3,7+1,2,3,8-TCDD

2,3,7,8-TCDD

1,2,3,9-TCDD

DB-225 Column TCDF Isomer Specificity Test Standard

2,3,4,7-TCDF

2,3,7,8-TCDF

1,2,3,9-TCDF

TABLE 6. ACCEPTANCE CRITERIA FOR PERFORMANCE TESTS WHEN ALL CDDS/CDFS ARE TESTED ¹

CDD/CDF	Test Conc. (ng/mL)	IPR ^{2,3}		OPR (ng/mL)	VER (ng/mL)
		s (ng/mL)	X (ng/mL)		
2,3,7,8-TCDD	10	2.8	8.3-12.9	6.7-15.8	7.8-12.9
2,3,7,8-TCDF	10	2.0	8.7-13.7	7.5-15.8	8.4-12.0
1,2,3,7,8-PeCDD	50	7.5	38-66	35-71	39-65
1,2,3,7,8-PeCDF	50	7.5	43-62	40-67	41-60
2,3,4,7,8-PeCDF	50	8.6	36-75	34-80	41-61
1,2,3,4,7,8-HxCDD	50	9.4	39-76	35-82	39-64
1,2,3,6,7,8-HxCDD	50	7.7	42-62	38-67	39-64
1,2,3,7,8,9-HxCDD	50	11.1	37-71	32-81	41-61
1,2,3,4,7,8-HxCDF	50	8.7	41-59	36-67	45-56
1,2,3,6,7,8-HxCDF	50	6.7	46-60	42-65	44-57
1,2,3,7,8,9-HxCDF	50	6.4	42-61	39-65	45-56
2,3,4,6,7,8-HxCDF	50	7.4	37-74	35-78	44-57
1,2,3,4,6,7,8-HpCDD	50	7.7	38-65	35-70	43-58
1,2,3,4,6,7,8-HpCDF	50	6.3	45-56	41-61	45-55
1,2,3,4,7,8,9-HpCDF	50	8.1	43-63	39-69	43-58
OCDD	100	19	89-127	78-144	79-126
OCDF	100	27	74-146	63-170	63-159
¹³ C ₁₂ -2,3,7,8-TCDD	100	37	28-134	20-175	82-121
¹³ C ₁₂ -2,3,7,8-TCDF	100	35	31-113	22-152	71-140
¹³ C ₁₂ -1,2,3,7,8-PeCDD	100	39	27-184	21-227	62-160
¹³ C ₁₂ -1,2,3,7,8-PeCDF	100	34	27-156	21-192	76-130
¹³ C ₁₂ -2,3,4,7,8-PeCDF	100	38	16-279	13-328	77-130
¹³ C ₁₂ -1,2,3,4,7,8-HxCDD	100	41	29-147	21-193	85-117
¹³ C ₁₂ -1,2,3,6,7,8-HxCDD	100	38	34-122	25-163	85-118
¹³ C ₁₂ -1,2,3,4,7,8-HxCDF	100	43	27-152	19-202	76-131
¹³ C ₁₂ -1,2,3,6,7,8-HxCDF	100	35	30-122	21-159	70-143
¹³ C ₁₂ -1,2,3,7,8,9-HxCDF	100	40	24-157	17-205	74-135
¹³ C ₁₂ -2,3,4,6,7,8,-HxCDF	100	37	29-136	22-176	73-137
¹³ C ₁₂ -1,2,3,4,6,7,8-HpCDD	100	35	34-129	26-166	72-138
¹³ C ₁₂ -1,2,3,4,6,7,8-HpCDF	100	41	32-110	21-158	78-129
¹³ C ₁₂ -1,2,3,4,7,8,9-HpCDF	100	40	28-141	20-186	77-129
¹³ C ₁₂ -OCDD	200	95	41-276	26-397	96-415
³⁷ Cl ₄ -2,3,7,8-TCDD	10	3.6	3.9-15.4	3.1-19.1	7.9-12.7

¹ All specifications are given as concentration in the final extract, assuming a 20 µL volume.² s = standard deviation of the concentration.³ X = average concentration.

TABLE 6A. ACCEPTANCE CRITERIA FOR PERFORMANCE TESTS WHEN ONLY TETRA COMPOUNDS ARE TESTED ¹

CDD/CDF	Test Conc. (ng/mL)	IPR ^{2,3}		OPR (ng/mL)	VER (ng/mL)
		s (ng/mL)	X (ng/mL)		
2,3,7,8-TCDD	10	2.7	8.7-12.4	7.3-14.6	8.2-12.3
2,3,7,8-TCDF	10	2.0	9.1-13.1	8.0-14.7	8.6-11.6
¹³ C ₁₂ -2,3,7,8-TCDD	100	35	32-115	25-141	85-117
¹³ C ₁₂ -2,3,7,8-TCDF	100	34	35-99	26-126	76-131
³⁷ Cl ₄ -2,3,7,8-TCDD	10	3.4	4.5-13.4	3.7-15.8	8.3-12.1

¹ All specifications are given as concentration in the final extract, assuming a 20 µL volume.

² s = standard deviation of the concentration.

³ X = average concentration.

TABLE 7. LABELED COMPOUND RECOVERY IN SAMPLES WHEN ALL CDDS/CDFS ARE TESTED

Compound	Test Conc. (ng/mL)	Labeled Compound Recovery	
		(ng/mL) ¹	(%)
¹³ C ₁₂ -2,3,7,8-TCDD	100	25-164	25-164
¹³ C ₁₂ -2,3,7,8-TCDF	100	24-169	24-169
¹³ C ₁₂ -1,2,3,7,8-PeCDD	100	25-181	25-181
¹³ C ₁₂ -1,2,3,7,8-PeCDF	100	24-185	24-185
¹³ C ₁₂ -2,3,4,7,8-PeCDF	100	21-178	21-178
¹³ C ₁₂ -1,2,3,4,7,8-HxCDD	100	32-141	32-141
¹³ C ₁₂ -1,2,3,6,7,8,-HxCDD	100	28-130	28-130
¹³ C ₁₂ -1,2,3,4,7,8-HxCDF	100	26-152	26-152
¹³ C ₁₂ -1,2,3,6,7,8-HxCDF	100	26-123	26-123
¹³ C ₁₂ -1,2,3,7,8,9-HxCDF	100	29-147	29-147
¹³ C ₁₂ -2,3,4,6,7,8,-HxCDF	100	28-136	28-136
¹³ C ₁₂ -1,2,3,4,6,7,8-HpCDD	100	23-140	23-140
¹³ C ₁₂ -1,2,3,4,6,7,8-HpCDF	100	28-143	28-143
¹³ C ₁₂ -1,2,3,4,7,8,9-HpCDF	100	26-138	26-138
¹³ C ₁₂ -OCDD	200	34-313	17-157
³⁷ Cl ₄ -2,3,7,8-TCDD	10	3.5-19.7	35-197

¹ Specification given as concentration in the final extract, assuming a 20-µL volume.

TABLE 7A. LABELED COMPOUND RECOVERY IN SAMPLES WHEN ONLY TETRA COMPOUNDS ARE TESTED

Compound	Test Conc. (ng/mL)	Labeled compound recovery	
		(ng/mL) ¹	(%)
¹³ C ₁₂ -2,3,7,8-TCDD	100	31-137	31-137
¹³ C ₁₂ -2,3,7,8-TCDF	100	29-140	29-140
³⁷ Cl ₄ -2,3,7,8-TCDD	10	4.2-16.4	42-164

¹ Specification given as concentration in the final extract, assuming a 20 µL volume.

TABLE 8. DESCRIPTORS, EXACT M/Z's, M/Z TYPES, AND ELEMENTAL COMPOSITIONS OF THE CDDs AND CDFs

Descriptor	Exact M/Z ¹	M/Z Type	Elemental Composition	Substance ²
1	292.9825	Lock	C ₇ F ₁₁	PFK
	303.9016	M	C ₁₂ H ₄ ³⁵ Cl ₄ O	TCDF
	305.8987	M+2	C ₁₂ H ₄ ³⁵ Cl ₃ ³⁷ Cl O	TCDF
	315.9419	M	¹³ C ₁₂ H ₄ ³⁵ Cl ₄ O	TCDF ³
	317.9389	M+2	¹³ C ₁₂ H ₄ ³⁵ Cl ₃ ³⁷ Cl O	TCDF ³
	319.8965	M	C ₁₂ H ₄ ³⁵ Cl ₄ O ₂	TCDD
	321.8936	M+2	C ₁₂ H ₄ ³⁵ Cl ₃ ³⁷ Cl O ₂	TCDD
	327.8847	M	C ₁₂ H ₄ ³⁷ Cl ₄ O ₂	TCDD ⁴
	330.9792	QC	C ₇ F ₁₃	PFK
	331.9368	M	¹³ C ₁₂ H ₄ ³⁵ Cl ₄ O ₂	TCDD ³
	333.9339	M+2	¹³ C ₁₂ H ₄ ³⁵ Cl ₃ ³⁷ Cl O ₂	TCDD ³
	375.8364	M+2	C ₁₂ H ₄ ³⁵ Cl ₅ ³⁷ Cl O	HxCDFE
	2	339.8597	M+2	C ₁₂ H ₃ ³⁵ Cl ₄ ³⁷ Cl O
341.8567		M+4	C ₁₂ H ₃ ³⁵ Cl ₃ ³⁷ Cl ₂ O	PeCDF
351.9000		M+2	¹³ C ₁₂ H ₃ ³⁵ Cl ₄ ³⁷ Cl O	PeCDF
353.8970		M+4	¹³ C ₁₂ H ₃ ³⁵ Cl ₃ ³⁷ Cl ₂ O	PeCDF ³
354.9792		Lock	C ₉ F ₁₃	PFK
355.8546		M+2	C ₁₂ H ₃ ³⁵ Cl ₄ ³⁷ Cl O ₂	PeCDD
357.8516		M+4	C ₁₂ H ₃ ³⁵ Cl ₃ ³⁷ Cl ₂ O ₂	PeCDD
367.8949		M+2	¹³ C ₁₂ H ₃ ³⁵ Cl ₄ ³⁷ Cl O ₂	PeCDD ³
369.8919		M+4	¹³ C ₁₂ H ₃ ³⁵ Cl ₃ ³⁷ Cl ₂ O ₂	PeCDD ³
409.7974		M+2	C ₁₂ H ₃ ³⁵ Cl ₆ ³⁷ Cl O	HpCDPE
3	373.8208	M+2	C ₁₂ H ₂ ³⁵ Cl ₅ ³⁷ Cl O	HxCDF
	375.8178	M+4	C ₁₂ H ₂ ³⁵ Cl ₄ ³⁷ Cl ₂ O	HxCDF
	383.8639	M	¹³ C ₁₂ H ₂ ³⁵ Cl ₆ O	HxCDF ³
	385.8610	M+2	¹³ C ₁₂ H ₂ ³⁵ Cl ₅ ³⁷ Cl O	HxCDF ³
	389.8157	M+2	C ₁₂ H ₂ ³⁵ Cl ₅ ³⁷ Cl O ₂	HxCDD
	391.8127	M+4	C ₁₂ H ₂ ³⁵ Cl ₄ ³⁷ Cl ₂ O ₂	HxCDD

TABLE 8. DESCRIPTORS, EXACT M/Z's, M/Z TYPES, AND ELEMENTAL COMPOSITIONS OF THE CDDs AND CDFs

Descriptor	Exact M/Z ¹	M/Z Type	Elemental Composition	Substance ²
	392.9760	Lock	C ₉ F ₁₅	PFK
	401.8559	M+2	¹³ C ₁₂ H ₂ ³⁵ Cl ₃ ³⁷ Cl O	HxCDD ³
	403.8529	M+4	¹³ C ₁₂ H ₂ ³⁵ Cl ₄ ³⁷ Cl ₂ O	HxCDD ³
	430.9729	QC	C ₉ F ₁₇	PFK
	445.7555	M+4	C ₁₂ H ₂ ³⁵ Cl ₆ ³⁷ Cl ₂ O	OCDPE
4	407.7818	M+2	C ₁₂ H ³⁵ Cl ₆ ³⁷ Cl O	HpCDF
	409.7789	M+4	C ₁₂ H ³⁵ Cl ₅ ³⁷ Cl ₂ O	HpCDF
	417.8253	M	¹³ C ₁₂ H ³⁵ Cl ₇ O	HpCDF ³
	419.8220	M+2	¹³ C ₁₂ H ³⁵ Cl ₆ ³⁷ Cl O	HpCDF ³
	423.7766	M+2	C ₁₂ H ³⁵ Cl ₆ ³⁷ Cl O ₂	HpCDD
	425.7737	M+4	C ₁₂ H ³⁵ Cl ₅ ³⁷ Cl ₂ O	HpCDD
	430.9729	Lock	C ₉ F ₁₇	PFK
	435.8169	M+2	¹³ C ₁₂ H ³⁵ Cl ₆ ³⁷ Cl O ₂	HpCDD ³
	437.8140	M+4	¹³ C ₁₂ H ³⁵ Cl ₅ ³⁷ Cl ₂ O	HpCDD ³
	479.7165	M+4	C ₁₂ H ³⁵ Cl ₇ ³⁷ Cl ₂ O	NCDPE
5	441.7428	M+2	C ₁₂ ³⁵ Cl ₇ ³⁷ Cl O	OCDF
	442.9728	Lock	C ₁₀ F ₁₇	PFK
	443.7399	M+4	C ₁₂ ³⁵ Cl ₆ ³⁷ Cl ₂ O	OCDF
	457.7377	M+2	C ₁₂ ³⁵ Cl ₇ ³⁷ Cl O ₂	OCDD
	459.7348	M+4	C ₁₂ ³⁵ Cl ₆ ³⁷ Cl ₂ O ₂	OCDD
	469.7779	M+2	¹³ C ₁₂ ³⁵ Cl ₇ ³⁷ Cl O ₂	OCDD ³
	471.7750	M+4	¹³ C ₁₂ ³⁵ Cl ₆ ³⁷ Cl ₂ O ₂	OCDD ³
	513.6775	M+4	C ₁₂ ³⁵ Cl ₈ ³⁷ Cl ₂ O	DCDPE

¹ Nuclidic masses used:

H = 1.007825	C = 12.00000	¹³ C = 13.003355	F = 18.9984
O = 15.994915	³⁵ Cl = 34.968853	³⁷ Cl = 36.965903	

² TCDD = Tetrachlorodibenzo- <i>p</i> -dioxin	TCDF = Tetrachlorodibenzofuran
PeCDD = Pentachlorodibenzo- <i>p</i> -dioxin	PeCDF = Pentachlorodibenzofuran
HxCDD = Hexachlorodibenzo- <i>p</i> -dioxin	HxCDF = Hexachlorodibenzofuran
HpCDD = Heptachlorodibenzo- <i>p</i> -dioxin	HpCDF = Heptachlorodibenzofuran
OCDD = Octachlorodibenzo- <i>p</i> -dioxin	OCDF = Octachlorodibenzofuran
HxCDPE = Hexachlorodiphenyl ether	HpCDPE = Heptachlorodiphenyl ether
OCDPE = Octachlorodiphenyl ether	NCDPE = Nonachlorodiphenyl ether
DCDPE = Decachlorodiphenyl ether	PFK = Perfluorokerosene

³ Labeled compound.⁴ There is only one m/z for ³⁷Cl₄-2,3,7,8,-TCDD (cleanup standard).

TABLE 9. THEORETICAL ION ABUNDANCE RATIOS AND QC LIMITS

Number of Chlorine Atoms	M/Z's Forming Ratio	Theoretical Ratio	QC Limit ¹	
			Lower	Upper
4 ²	M/(M+2)	0.77	0.65	0.89
5	(M+2)/(M+4)	1.55	1.32	1.78
6	(M+2)/(M+4)	1.24	1.05	1.43
6 ³	M/(M+2)	0.51	0.43	0.59
7	(M+2)/(M+4)	1.05	0.88	1.20
7 ⁴	M/(M+2)	0.44	0.37	0.51
8	(M+2)/(M+4)	0.89	0.76	1.02

¹ QC limits represent $\pm 15\%$ windows around the theoretical ion abundance ratios.

² Does not apply to ³⁷Cl₄-2,3,7,8-TCDD (cleanup standard).

³ Used for ¹³C₁₂-HxCDF only.

⁴ Used for ¹³C₁₂-HpCDF only.

TABLE 10. SUGGESTED SAMPLE QUANTITIES TO BE EXTRACTED FOR VARIOUS MATRICES ¹

Sample Matrix ²	Example	Percent Solids	Phase	Quantity Extracted
<i>Single-phase</i>				
Aqueous	Drinking water Groundwater Treated wastewater	<1	— ³	1000 mL
Solid	Dry soil Compost Ash	>20	Solid	10 g
Organic	Waste solvent Waste oil Organic polymer	<1	Organic	10 g
Tissue	Fish Human adipose	—	Organic	10 g
<i>Multi-phase</i>				
<i>Liquid/Solid</i>				
Aqueous/Solid	Wet soil Untreated effluent Digested municipal sludge Filter cake Paper pulp	1–30	Solid	10 g
Organic/solid	Industrial sludge Oily waste	1–100	Both	10 g
<i>Liquid/Liquid</i>				
Aqueous/organic	In-process effluent Untreated effluent Drum waste	<1	Organic	10 g
Aqueous/organic/solid	Untreated effluent Drum waste	>1	Organic & solid	10 g

¹ The quantity of sample to be extracted is adjusted to provide 10 g of solids (dry weight). One liter of aqueous samples containing 1% solids will contain 10 g of solids. For aqueous samples containing greater than 1% solids, a lesser volume is used so that 10 g of solids (dry weight) will be extracted.

² The sample matrix may be amorphous for some samples. In general, when the CDDs/CDFs are in contact with a multiphase system in which one of the phases is water, they will be preferentially dispersed in or adsorbed on the alternate phase because of their low solubility in water.

³ Aqueous samples are filtered after spiking with the labeled compounds. The filtrate and the materials trapped on the filter are extracted separately, and the extracts are combined for cleanup and analysis.

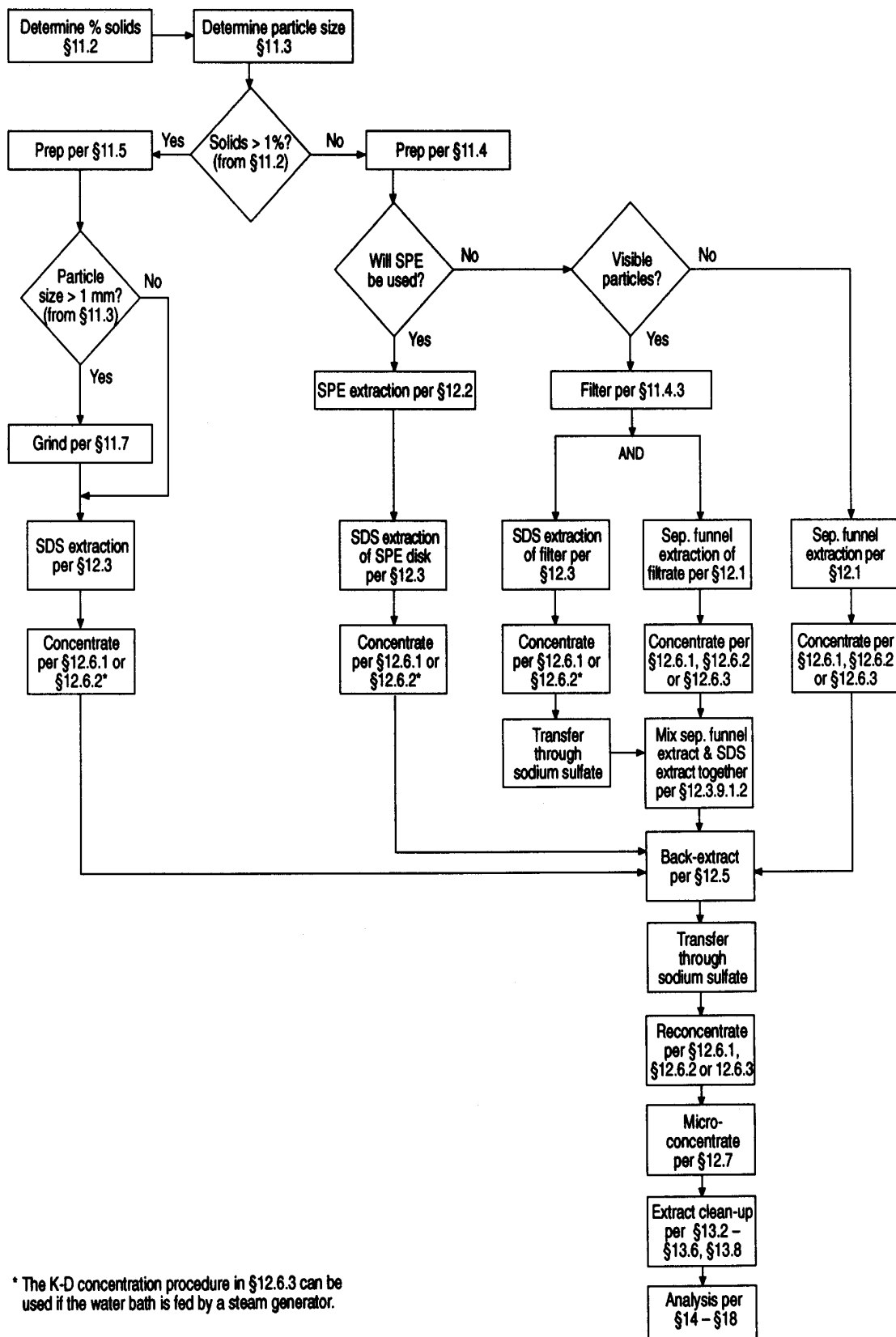

52-028-1A

Figure 1. Flow Chart for Analysis of Aqueous and Solid Samples

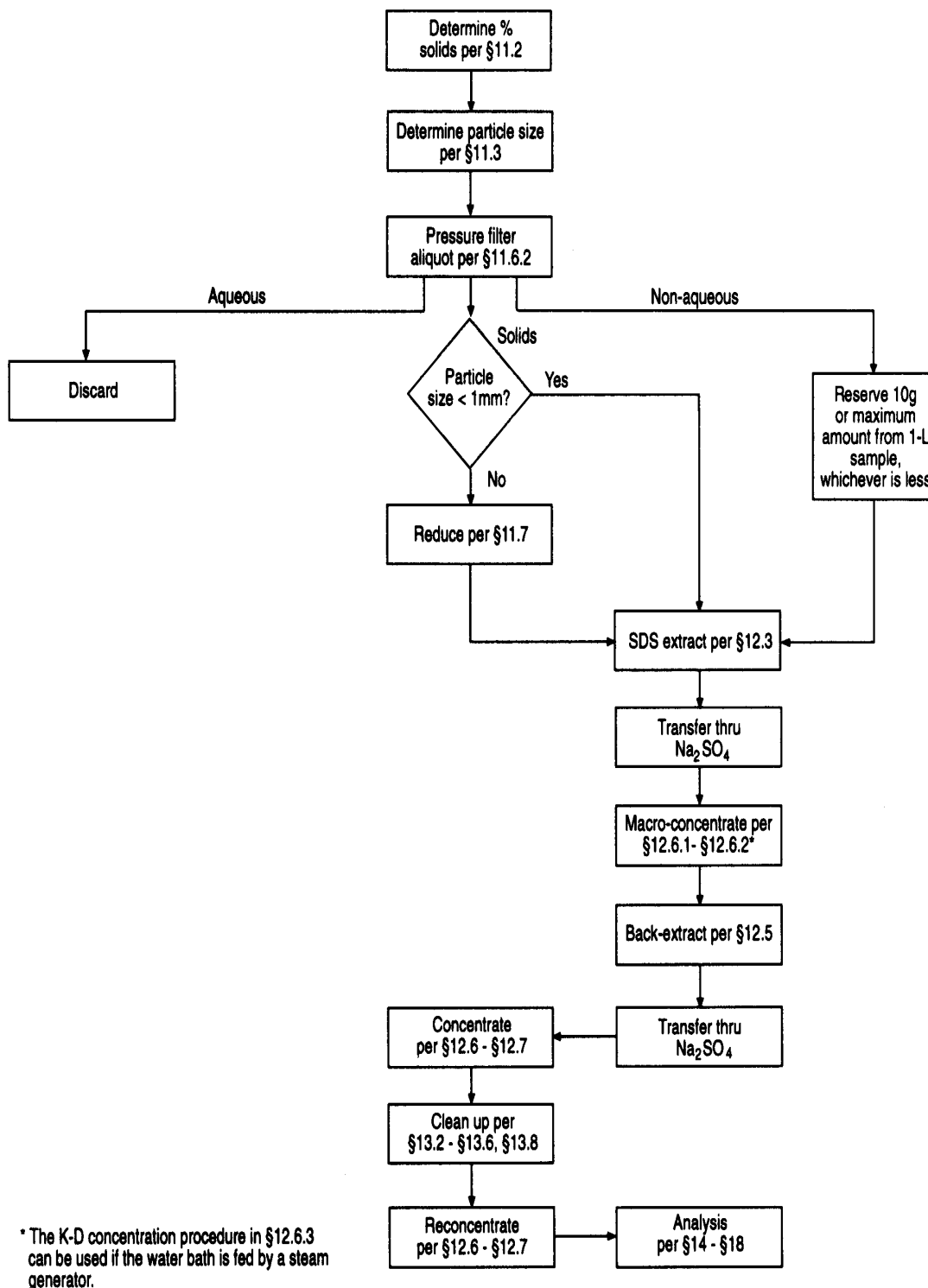
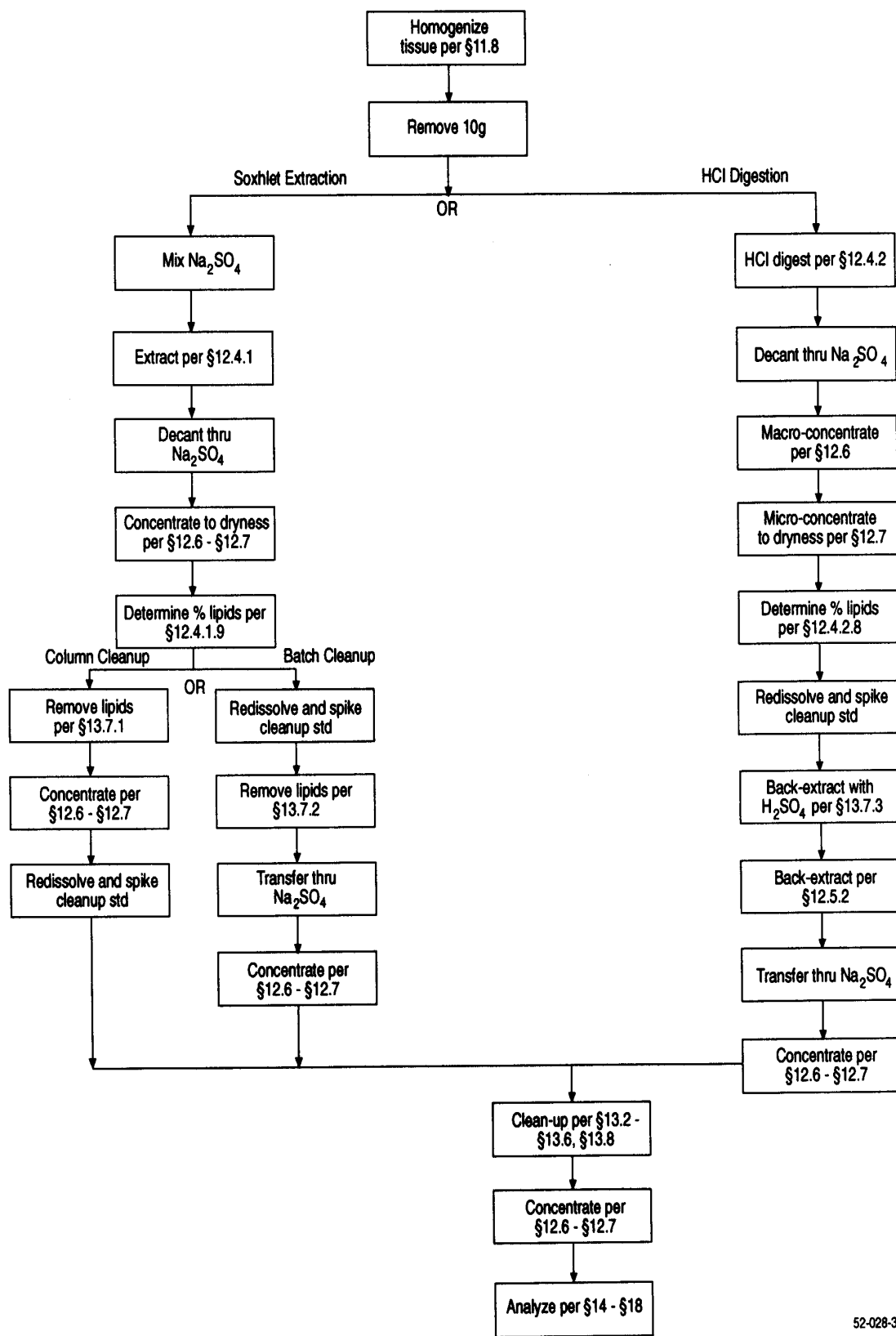

Figure 2. Flow Chart for Analysis of Multi-Phase Samples

52-028-2A



52-028-3A

Figure 3. Flow Chart for Analysis of Tissue Samples

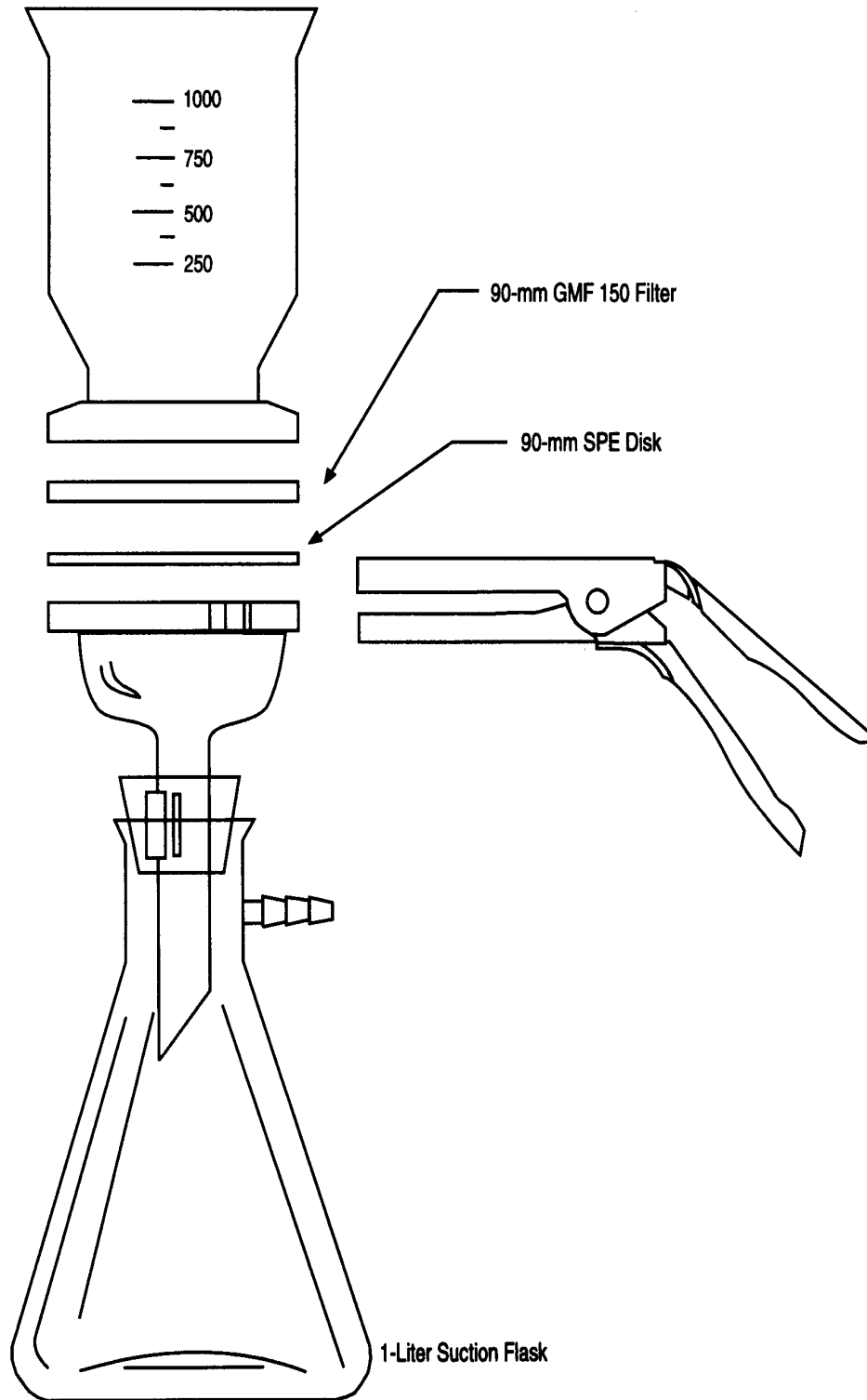
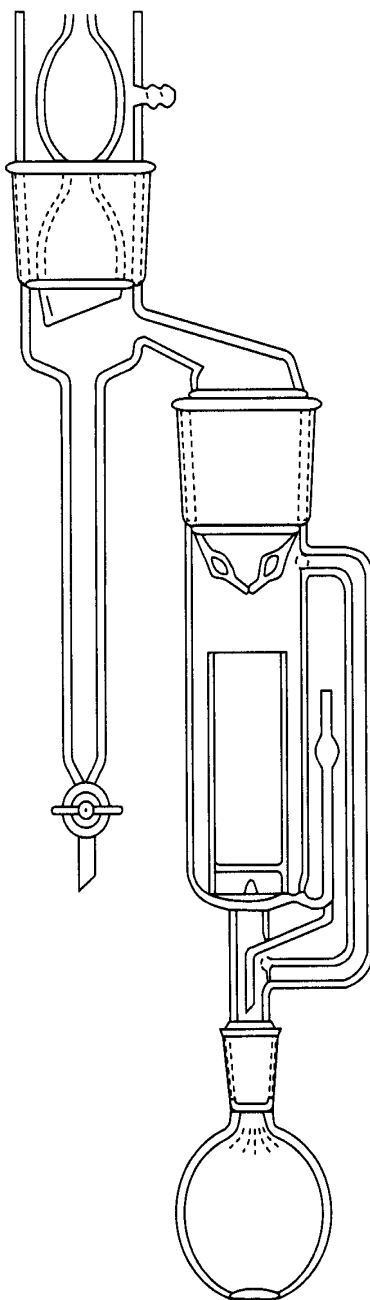

Figure 4. Solid-Phase Extraction Apparatus

52-027-1A



52-027-2A

Figure 5. Soxhlet/Dean-Stark Extractor

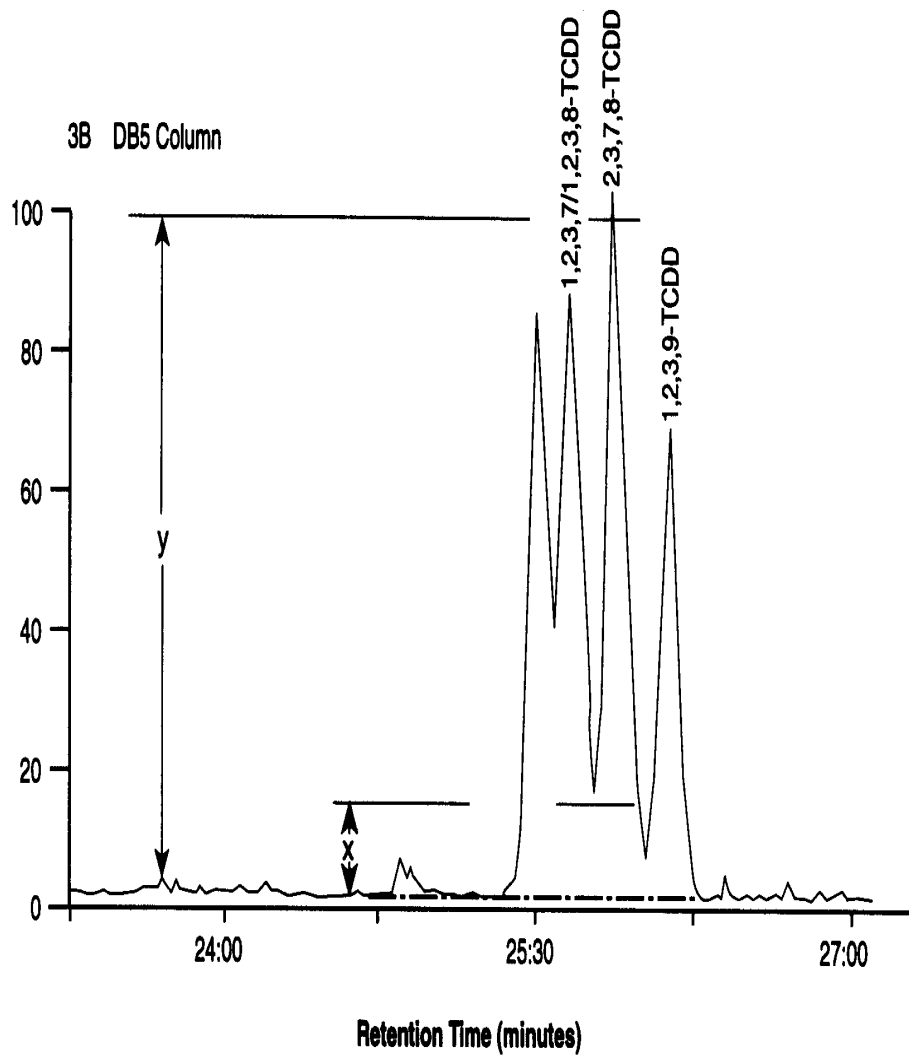

Figure 6. Isomer-Specific Separation of 2,3,7,8-TCDD on DB-5 Column

52-027-03

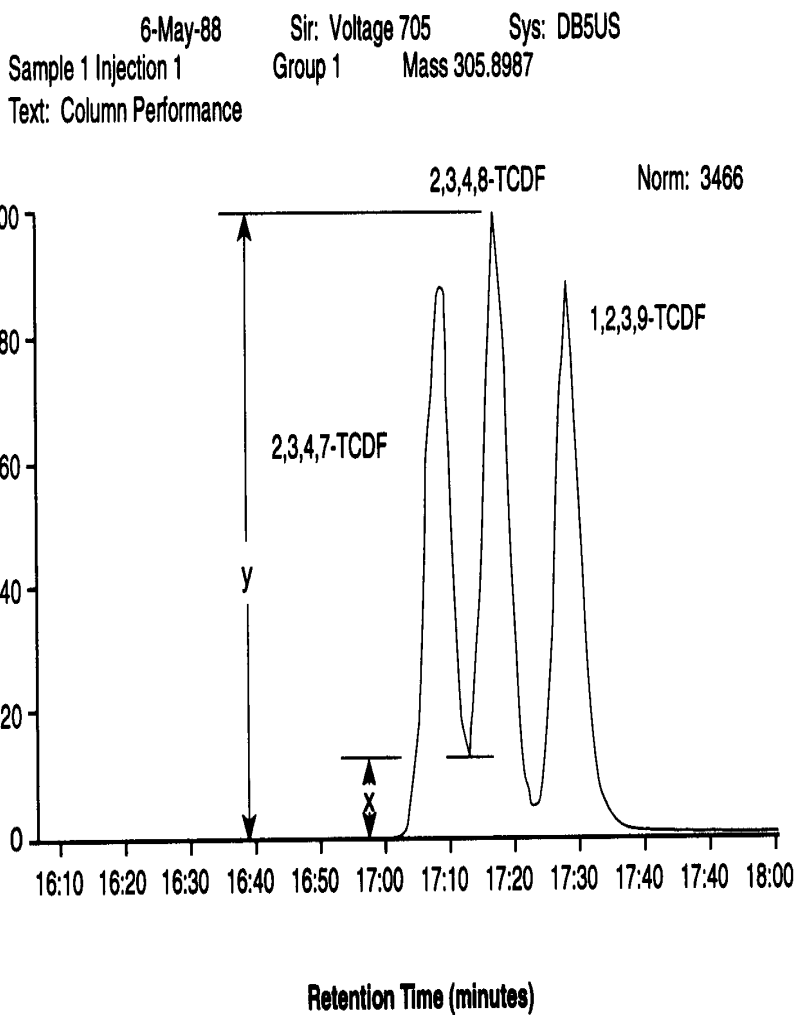

Figure 7. Isomer-Specific Separation of 2,3,7,8-TCDF on DB-5 Column

52-027-4A

24.0 Glossary of Definitions and Purposes

These definitions and purposes are specific to this method but have been conformed to common usage as much as possible.

24.1 Units of weight and Measure and Their Abbreviations

24.1.1 Symbols

°C	degrees Celsius
µL	microliter
µm	micrometer
<	less than
>	greater than
%	percent

24.1.2 Alphabetical abbreviations

amp	ampere
cm	centimeter
g	gram
h	hour
ID	inside diameter
in.	inch
L	liter
M	Molecular ion
m	meter
mg	milligram
min	minute
mL	milliliter
mm	millimeter
m/z	mass-to-charge ratio
N	normal; gram molecular weight of solute divided by hydrogen equivalent of solute, per liter of solution
OD	outside diameter
pg	picogram
ppb	part-per-billion
ppm	part-per-million
ppq	part-per-quadrillion
ppt	part-per-trillion
psig	pounds-per-square inch gauge
v/v	volume per unit volume
w/v	weight per unit volume

24.2 Definitions and Acronyms (in Alphabetical Order)

Analyte—A CDD or CDF tested for by this method. The analytes are listed in Table 1.

Calibration Standard (CAL)—A solution prepared from a secondary standard and/or stock solutions and used to calibrate the response of the instrument with respect to analyte concentration.

Calibration Verification Standard (VER)—The mid-point calibration standard (CS3) that is used in to verify calibration. See Table 4.

CDD—Chlorinated Dibenzo-*p*-ioxin—The isomers and congeners of tetra- through octa-chlorodibenzo-*p*-dioxin.

CDF—Chlorinated Dibenzofuran—The isomers and congeners of tetra- through octa-chlorodibenzofuran.

CS1, CS2, CS3, CS4, CS5—See Calibration standards and Table 4.

Field Blank—An aliquot of reagent water or other reference matrix that is placed in a sample container in the laboratory or the field, and treated as a sample in all respects, including exposure to sampling site conditions, storage, preservation, and all analytical procedures. The purpose of the field blank is to determine if the field or sample transporting procedures and environments have contaminated the sample.

GC—Gas chromatograph or gas chromatography.

GPC—Gel permeation chromatograph or gel permeation chromatography.

HPLC—High performance liquid chromatograph or high performance liquid chromatography.

HRGC—High resolution GC.

HRMS—High resolution MS.

IPR—Initial precision and recovery; four aliquots of the diluted PAR standard analyzed to establish the ability to generate acceptable precision and accuracy. An IPR is performed prior to the first time this method is used and any time the method or instrumentation is modified.

K-D—Kuderna-Danish concentrator; a device used to concentrate the analytes in a solvent.

Laboratory Blank—See method blank.

Laboratory Control sample (LCS)—See ongoing precision and recovery standard (OPR).

Laboratory Reagent Blank—See method blank.

May—This action, activity, or procedural step is neither required nor prohibited.

May Not—This action, activity, or procedural step is prohibited.

Method Blank—An aliquot of reagent water that is treated exactly as a sample including exposure to all glassware, equipment, solvents, reagents, internal standards, and surrogates that are used with samples. The method blank is used to determine if analytes or interferences are present in the laboratory environment, the reagents, or the apparatus.

Minimum Level (ML)—The level at which the entire analytical system must give a recognizable signal and acceptable calibration point for the analyte. It is equivalent to the concentration of the lowest calibration standard, assuming that all method-specified sample weights, volumes, and cleanup procedures have been employed.

MS—Mass spectrometer or mass spectrometry.

Must—This action, activity, or procedural step is required.

OPR—Ongoing precision and recovery standard (OPR); a laboratory blank spiked with known quantities of analytes. The OPR is analyzed exactly like a sample. Its purpose is to assure that the results produced by the laboratory remain within the limits specified in this method for precision and recovery.

PAR—Precision and recovery standard; secondary standard that is diluted and spiked to form the IPR and OPR.

PFK—Perfluorokerosene; the mixture of compounds used to calibrate the exact m/z scale in the HRMS.

Preparation Blank—See method blank.

Primary Dilution Standard—A solution containing the specified analytes that is purchased or prepared from stock solutions and diluted as needed to prepare calibration solutions and other solutions.

Quality Control Check Sample (QCS)—A sample containing all or a subset of the analytes at known concentrations. The QCS is obtained from a source external to the laboratory or is prepared from a source of standards different from the source of calibration standards. It is used to check laboratory performance with test materials prepared external to the normal preparation process.

Reagent Water—Water demonstrated to be free from the analytes of interest and potentially interfering substances at the method detection limit for the analyte.

Relative Standard Deviation (RSD)—The standard deviation times 100 divided by the mean. Also termed "coefficient of variation."

RF—Response factor. See Section 10.6.1.

RR—Relative response. See Section 10.5.2.

RSD—See relative standard deviation.

SDS—Soxhlet/Dean-Stark extractor; an extraction device applied to the extraction of solid and semi-solid materials (Reference 7).

Should—This action, activity, or procedural step is suggested but not required.

SICP—Selected ion current profile; the line described by the signal at an exact m/z.

SPE—Solid-phase extraction; an extraction technique in which an analyte is extracted from an aqueous sample by passage over or through a material capable of reversibly adsorbing the analyte. Also termed liquid-solid extraction.

Stock Solution—A solution containing an analyte that is prepared using a reference material traceable to EPA, the National Institute of Science and Technology (NIST), or a source that will attest to the purity and authenticity of the reference material.

TCDD—Tetrachlorodibenzo-*p*-dioxin.

TCDF—Tetrachlorodibenzofuran.

VER—See calibration verification standard.

Annex XIX:

Method 1668

**Toxic Polychlorinated Biphenyls by Isotope Dilution High Resolution Gas
Chromatography/High Resolution Mass Spectrometry**

United States
Environmental Protection
Agency

Office of Water
(4303)

EPA-821-R-97-001
March 1997
DRAFT



Method 1668

Toxic Polychlorinated Biphenyls by Isotope Dilution High Resolution Gas Chromatography/High Resolution Mass Spectrometry





Method 1668

Toxic Polychlorinated Biphenyls by Isotope Dilution High Resolution Gas Chromatography/High Resolution Mass Spectrometry

Method 1668

Acknowledgments

Method 1668 was prepared under the direction of William A. Telliard of the Engineering and Analysis Division within the EPA Office of Water (OW). This document was prepared under EPA Contract No. 68-C3-0337 by DynCorp Environmental, Energy & National Security Programs with assistance from its subcontractor Interface, Inc.

Disclaimer

This method has been reviewed by the Engineering and Analysis Division, U.S. Environmental Protection Agency, and approved for publication. Mention of trade names or commercial products does not constitute endorsement or recommendation for use.

Note: *This method is a draft based on preliminary validation in a single laboratory. In surveys of several laboratories using this method, EPA has found that it is normal for background levels of certain congeners that are found in high concentrations in PCBs to be present in the analytical systems in this method. Therefore, the concentrations of certain congeners in calibration and other solutions have been adjusted for these backgrounds. EPA welcomes constructive suggestions for improvement of this method.*

Introduction

Method 1668 was developed by the United States Environmental Protection Agency's Office of Science and Technology for congener-specific determination of the toxic co-planar and mono-ortho-substituted polychlorinated biphenyls (PCBs) in aqueous, solid, and tissue matrices by isotope dilution, high resolution capillary column gas chromatography (HRGC)/high resolution mass spectrometry (HRMS).

Questions and comments concerning this method or its application should be addressed to:

William A. Telliard, Director
Analytical Methods Staff (4303)
U.S. Environmental Protection Agency
401 M Street, SW
Washington, DC 20460
Phone: 202-260-7120
Fax: 202-260-7134

Method 1668

Method 1668

Toxic Polychlorinated Biphenyls by Isotope Dilution High Resolution Gas Chromatography/High Resolution Mass Spectrometry

1.0 Scope and Application

- 1.1 This method is for determination of the toxic polychlorinated biphenyls (PCBs) in water, soil, sediment, sludge, tissue, and other sample matrices by high resolution gas chromatography/high resolution mass spectrometry (HRGC/HRMS). The method is for use in EPA's data gathering and monitoring programs associated with the Clean Water Act, the Resource Conservation and Recovery Act, the Comprehensive Environmental Response, Compensation and Liability Act, and the Safe Drinking Water Act. The method is based on a compilation of methods from the technical literature (References 1-3) and on EPA Method 1613.
- 1.2 The toxic PCBs listed in Table 1 (Reference 4) and other specific congeners may be determined by this method.
- 1.3 The detection limits and quantitation levels in this method are usually dependent on the level of interferences rather than instrumental limitations. The minimum levels (MLs) in Table 2 are the levels at which the PCBs can be determined with only common laboratory interferences present. The Method Detection Limit (MDL) for PCB #126 has been determined as 40 pg/L (picograms/Liter; parts-per-quadrillion) in water using this method.
- 1.4 The GC/MS portions of this method are for use only by analysts experienced with HRGC/HRMS or under the close supervision of such qualified persons. Each laboratory that uses this method must demonstrate the ability to generate acceptable results using the procedure in Section 9.2.
- 1.5 This method is performance-based. The analyst is permitted to modify the method to overcome interferences or lower the cost of measurements, provided that all performance criteria in this method are met. The requirements for establishing method equivalency are given in Section 9.1.2.
- 1.6 Any modification of this method, beyond those expressly permitted, shall be considered a major modification subject to application and approval of alternate test procedures under 40 CFR Parts 136.4 and 136.5.

2.0 Summary of Method

Flow charts that summarize procedures for sample preparation, extraction, and analysis are given in Figure 1 for aqueous and solid samples, Figure 2 for multi-phase samples, and Figure 3 for tissue samples.

Method 1668

2.1 Extraction.

- 2.1.1** Aqueous samples (samples containing less than 1% solids)—Stable isotopically labeled analogs of the toxic PCBs are spiked into a 1-L sample, and the sample is vacuum-filtered through a glass-fiber filter on top of a solid-phase extraction (SPE) disk. Sample components on the filter and disk are eluted with methylene chloride and the eluant is concentrated for cleanup.
- 2.1.2** Solid, semi-solid, and multi-phase samples (but not tissue)—The labeled compounds are spiked into a sample containing 10 g (dry weight) of solids. Samples containing multiple phases are pressure filtered and any aqueous liquid is discarded. Coarse solids are ground or homogenized. Any non-aqueous liquid from multi-phase samples is combined with the solids and extracted in an SDS extractor. The extract is concentrated for cleanup.
- 2.1.3** Fish and other tissue—A 20-g aliquot of sample is homogenized, and a 10-g aliquot is spiked with the labeled compounds. The sample is mixed with sodium sulfate, allowed to dry for 12-24 hours, and extracted for 18-24 hours using methylene chloride:n-hexane (1:1) in a Soxhlet extractor. The extract is evaporated to dryness, and the lipid content is determined.

2.2 After extraction, samples are cleaned up using back-extraction with sulfuric acid and/or base, and gel permeation, silica gel, Florisil and activated carbon chromatography. High-performance liquid chromatography (HPLC) can be used for further isolation of specific isomers or congeners. Prior to the cleanup procedures cited above, tissue extracts are cleaned up using an anthropogenic isolation column.

2.3 After cleanup, the extract is concentrated to near dryness. Immediately prior to injection, internal standards are added to each extract, and an aliquot of the extract is injected into the gas chromatograph. The analytes are separated by the GC and detected by a high-resolution ($\geq 10,000$) mass spectrometer. Two exact m/z 's are monitored for each analyte.

2.4 An individual PCB congener is identified by comparing the GC retention time and ion-abundance ratio of two exact m/z 's with the corresponding retention time of an authentic standard and the theoretical or acquired ion-abundance ratio of the two exact m/z 's. Isomer specificity for the toxic PCBs is achieved using GC columns that resolve these congeners from the other PCBs.

2.5 Quantitative analysis is performed using selected ion current profile (SICP) areas in one of two ways:

- 2.5.1** For PCBs with labeled analogs (see Table 1), the GC/MS system is calibrated, and the concentration of each compound is determined using the isotope dilution technique.
- 2.5.2** For PCBs without labeled compounds, the GC/MS system is calibrated, and the concentration of each compound is determined using the internal standard technique.

2.6 The quality of the analysis is assured through reproducible calibration and testing of the extraction, cleanup, and GC/MS systems.

3.0 Definitions

Definitions are given in the glossary at the end of this method.

4.0 Contamination and Interferences

- 4.1 Solvents, reagents, glassware, and other sample processing hardware may yield artifacts and/or elevated baselines causing misinterpretation of chromatograms. Specific selection of reagents and purification of solvents by distillation in all-glass systems may be required. Where possible, reagents are cleaned by extraction or solvent rinse. The non-coplanar PCB congeners 105, 114, 118, 123, 156, 157, 167, and 180 have been shown to be very difficult to completely eliminate from the laboratory at the MDLs in this method, and baking of glassware in a kiln or furnace at 450-500 °C may be necessary to remove these and other contaminants.
- 4.2 Proper cleaning of glassware is extremely important because glassware may not only contaminate the samples but may also remove the analytes of interest by adsorption on the glass surface.
- 4.2.1 Glassware should be rinsed with solvent and washed with a detergent solution as soon after use as is practical. Sonication of glassware containing a detergent solution for approximately 30 seconds may aid in cleaning. Glassware with removable parts, particularly separatory funnels with fluoropolymer stopcocks, must be disassembled prior to detergent washing.
- 4.2.2 After detergent washing, glassware should be rinsed immediately; first with methanol, then with hot tap water. The tap water rinse is followed by another methanol rinse, then acetone, and then methylene chloride.
- 4.2.3 Baking of glassware in kiln or other high temperature furnace (450-500 °C) may be warranted after particularly dirty samples are encountered. However, baking should be minimized, as repeated baking of glassware may cause active sites on the glass surface that may irreversibly adsorb PCBs.
- 4.2.4 Immediately prior to use, the Soxhlet apparatus should be pre-extracted with toluene for approximately 3 hours (see Sections 12.3.1-12.3.3). The solid-phase extraction apparatus (Section 6.4.1.5) should be rinsed with methylene chloride/toluene (80/20 mixture).
- 4.3 All materials used in the analysis shall be demonstrated to be free from interferences by running reference matrix method blanks (Section 9.5) initially and with each sample batch (samples started through the extraction process on a given 12-hour shift to a maximum of 20 samples).
- 4.3.1 The reference matrix must simulate as closely as possible the sample matrix under test. Ideally, the reference matrix should not contain the PCBs in detectable amounts, but should contain potential interferents in the concentrations expected to be found in the samples to be analyzed.
- 4.3.2 When a reference matrix that simulates the sample matrix under test is not available, reagent water (Section 7.6.1) can be used to simulate water samples; playground sand (Section 7.6.2) or white quartz sand (Section 7.3.2) can be used to simulate soils; filter paper (Section 7.6.3) can be used to simulate papers and similar materials; and corn oil (Section 7.6.4) can be used to simulate tissues.
- 4.4 Interferences coextracted from samples will vary considerably from source to source, depending on the diversity of the site being sampled. Interfering compounds may be present at concentrations several orders of magnitude higher than the PCBs. The most frequently encountered interferences are chlorinated dioxins and dibenzofurans, methoxy biphenyls, hydroxy-diphenyl ethers, benzylphenyl ethers, polynuclear aromatics, and pesticides. Because very low

Method 1668

levels of PCBs are measured by this method, the elimination of interferences is essential. The cleanup steps given in Section 13 can be used to reduce or eliminate these interferences and thereby permit reliable determination of the PCBs at the levels shown in Table 2.

- 4.5 Each piece of reusable glassware should be numbered to associate that glassware with the processing of a particular sample. This will assist the laboratory in tracking possible sources of contamination for individual samples, identifying glassware associated with highly contaminated samples that may require extra cleaning, and determining when glassware should be discarded.
- 4.6 Cleanup of tissue—The natural lipid content of tissue can interfere in the analysis of tissue samples for the PCBs. The lipid contents of different species and portions of tissue can vary widely. Lipids are soluble to varying degrees in various organic solvents and may be present in sufficient quantity to overwhelm the column chromatographic cleanup procedures used for cleanup of sample extracts. Lipids must be removed by the lipid removal procedures in Section 13.6, followed by Florisil (Section 13.7), and carbon (Section 13.4) as minimum additional cleanup steps.

5.0 Safety

- 5.1 The toxicity or carcinogenicity of each chemical used in this method has not been precisely determined; however, each compound should be treated as a potential health hazard. Exposure to these compounds should be reduced to the lowest possible level.
- 5.1.1 The PCBs have been tentatively classified as known or suspected human or mammalian carcinogens. On the basis of the available toxicological and physical properties of the PCBs, pure standards should be handled only by highly trained personnel thoroughly familiar with handling and cautionary procedures and the associated risks.
- 5.1.2 It is recommended that the laboratory purchase dilute standard solutions of the analytes in this method. However, if primary solutions are prepared, they shall be prepared in a hood, and a NIOSH/MESA approved toxic gas respirator shall be worn when high concentrations are handled.
- 5.2 The laboratory is responsible for maintaining a current awareness file of OSHA regulations regarding the safe handling of the chemicals specified in this method. A reference file of material safety data sheets (MSDSs) should also be made available to all personnel involved in these analyses. It is also suggested that the laboratory perform personal hygiene monitoring of each analyst who uses this method and that the results of this monitoring be made available to the analyst. Additional information on laboratory safety can be found in References 5-8. The references and bibliography at the end of Reference 8 are particularly comprehensive in dealing with the general subject of laboratory safety.
- 5.3 The pure PCBs and samples suspected to contain these compounds are handled using essentially the same techniques employed in handling radioactive or infectious materials. Well-ventilated, controlled access laboratories are required. Assistance in evaluating the health hazards of particular laboratory conditions may be obtained from certain consulting laboratories and from State Departments of Health or Labor, many of which have an industrial health service. Each laboratory must develop a strict safety program for handling these compounds. The practices in Reference 11 for handling chlorinated dibenzo-*p*-dioxins and dibenzofurans (CDDs/CDFs) are also recommended for handling the toxic PCBs.

- 5.3.1 Facility**—When finely divided samples (dusts, soils, dry chemicals) are handled, all operations (including removal of samples from sample containers, weighing, transferring, and mixing) should be performed in a glove box demonstrated to be leak tight or in a fume hood demonstrated to have adequate air flow. Gross losses to the laboratory ventilation system must not be allowed. Handling of the dilute solutions normally used in analytical and animal work presents no inhalation hazards except in the case of an accident.
- 5.3.2 Protective equipment**—Disposable plastic gloves, apron or lab coat, safety glasses or mask, and a glove box or fume hood adequate for radioactive work should be used. During analytical operations that may give rise to aerosols or dusts, personnel should wear respirators equipped with activated carbon filters. Eye protection equipment (preferably full face shields) must be worn while working with exposed samples or pure analytical standards. Latex gloves are commonly used to reduce exposure of the hands. When handling samples suspected or known to contain high concentrations of the PCBs, an additional set of gloves can also be worn beneath the latex gloves.
- 5.3.3 Training**—Workers must be trained in the proper method of removing contaminated gloves and clothing without contacting the exterior surfaces.
- 5.3.4 Personal hygiene**—Hands and forearms should be washed thoroughly after each manipulation and before breaks (coffee, lunch, and shift).
- 5.3.5 Confinement**—Isolated work areas posted with signs, segregated glassware and tools, and plastic absorbent paper on bench tops will aid in confining contamination.
- 5.3.6 Effluent vapors**—The effluents of sample splitters from the gas chromatograph (GC) and from roughing pumps on the mass spectrometer (MS) should pass through either a column of activated charcoal or be bubbled through a trap containing oil or high-boiling alcohols to condense PCB vapors.
- 5.3.7 Waste Handling**—Good technique includes minimizing contaminated waste. Plastic bag liners should be used in waste cans. Janitors and other personnel must be trained in the safe handling of waste.
- 5.3.8 Decontamination.**
- 5.3.8.1 Decontamination of personnel**—Use any mild soap with plenty of scrubbing action.
- 5.3.8.2 Glassware, tools, and surfaces**—Chloroethene NU Solvent is a less toxic solvent that should be effective in removing PCBs. Satisfactory cleaning may be accomplished by rinsing with Chloroethene, then washing with any detergent and water. If glassware is first rinsed with solvent, then the dish water may be disposed of in the sewer. Given the cost of disposal, it is prudent to minimize solvent wastes.
- 5.3.9 Laundry**—Clothing known to be contaminated should be collected in plastic bags. Persons who convey the bags and launder the clothing should be advised of the hazard and trained in proper handling. The clothing may be put into a washer without contact if the launderer knows of the potential problem. The washer should be run through a cycle before being used again for other clothing.
- 5.3.10 Wipe tests**—A useful method of determining cleanliness of work surfaces and tools is to wipe the surface with a piece of filter paper. Extraction and analysis by GC with an electron capture detector (ECD) can achieve a limit of detection of 0.1 g per wipe; analysis

Method 1668

using this method can achieve an even lower detection limit. Less than 0.1 µg per wipe indicates acceptable cleanliness; anything higher warrants further cleaning. More than 10 µg on a wipe constitutes an acute hazard and requires prompt cleaning before further use of the equipment or work space, and indicates that unacceptable work practices have been employed.

6.0 Apparatus, Equipment and Supplies

Note: *Brand names, suppliers, and part numbers are for illustration purposes only and no endorsement is implied. Equivalent performance may be achieved using apparatus and materials other than those specified here. Meeting the performance requirements of this method is the responsibility of the laboratory.*

6.1 Sampling equipment for discrete or composite sampling.

6.1.1 Sample bottles and caps.

- 6.1.1.1 Liquid samples (waters, sludges and similar materials containing 5% solids or less)—Sample bottle, amber glass, 1.1-L minimum, with screw cap.
- 6.1.1.2 Solid samples (soils, sediments, sludges, paper pulps, filter cake, compost, and similar materials that contain more than 5% solids)—Sample bottle, wide mouth, amber glass, 500-mL minimum.
- 6.1.1.3 If amber bottles are not available, samples shall be protected from light.
- 6.1.1.4 Bottle caps—Threaded to fit sample bottles. Caps shall be lined with fluoropolymer.
- 6.1.1.5 Cleaning.

6.1.1.5.1 Bottles are detergent water washed, then solvent rinsed before use.

6.1.1.5.2 Liners are detergent water washed and rinsed with reagent water (Section 7.6.1).

- 6.1.2 Compositing equipment—Automatic or manual compositing system incorporating glass containers cleaned per bottle cleaning procedure above. Only glass or fluoropolymer tubing shall be used. If the sampler uses a peristaltic pump, a minimum length of compressible silicone rubber tubing may be used in the pump only. Before use, the tubing shall be thoroughly rinsed with methanol, followed by repeated rinsing with reagent water to minimize sample contamination. An integrating flow meter is used to collect proportional composite samples.

6.2 Equipment for glassware cleaning—Laboratory sink with overhead fume hood.

6.3 Equipment for sample preparation.

- 6.3.1 Laboratory fume hood of sufficient size to contain the sample preparation equipment listed below.
- 6.3.2 Glove box (optional).
- 6.3.3 Tissue homogenizer—VirTis Model 45 Macro homogenizer (American Scientific Products H-3515, or equivalent) with stainless steel Macro-shaft and Turbo-shear blade.
- 6.3.4 Meat grinder—Hobart, or equivalent, with 3- to 5-mm holes in inner plate.

- 6.3.5 Equipment for determining percent moisture.
 - 6.3.5.1 Oven—Capable of maintaining a temperature of $110 \pm 5^\circ\text{C}$.
 - 6.3.5.2 Desiccator.
- 6.3.6 Balances.
 - 6.3.6.1 Analytical—Capable of weighing 0.1 mg.
 - 6.3.6.2 Top loading—Capable of weighing 10 mg.
- 6.4 Extraction apparatus.
 - 6.4.1 Water samples.
 - 6.4.1.1 pH meter, with combination glass electrode.
 - 6.4.1.2 pH paper, wide range (Hydrion Papers, or equivalent).
 - 6.4.1.3 Graduated cylinder, 1-L capacity.
 - 6.4.1.4 Liquid/liquid extraction—Separatory funnels, 250-, 500-, and 2000-mL, with fluoropolymer stopcocks.
 - 6.4.1.5 Solid-phase extraction.
 - 6.4.1.5.1 1-L filtration apparatus, including glass funnel, frit support, clamp, adapter, stopper, filtration flask, and vacuum tubing (Figure 4). For wastewater samples, the apparatus should accept 90 or 144 mm disks. For drinking water or other samples containing low solids, smaller disks may be used.
 - 6.4.1.5.2 Vacuum source capable of maintaining 25 in. Hg, equipped with shutoff valve and vacuum gauge.
 - 6.4.1.5.3 Glass-fiber filter—Whatman GMF 150 (or equivalent), 1 micron pore size, to fit filtration apparatus in Section 6.4.1.5.1.
 - 6.4.1.5.4 Solid-phase extraction disk containing octadecyl (C_{18}) bonded silica uniformly enmeshed in an inert matrix—Fisher Scientific 14-378F (or equivalent), to fit filtration apparatus in Section 6.4.1.5.1.
 - 6.4.2 Soxhlet/Dean-Stark (SDS) extractor (Figure 5 and Reference 12) for filters and solid/sludge samples.
 - 6.4.2.1 Soxhlet—50-mm ID, 200-mL capacity with 500-mL flask (Cal-Glass LG-6900, or equivalent, except substitute 500-mL round-bottom flask for 300-mL flat-bottom flask).
 - 6.4.2.2 Thimble— 43×123 to fit Soxhlet (Cal-Glass LG-6901-122, or equivalent).
 - 6.4.2.3 Moisture trap—Dean Stark or Barret with fluoropolymer stopcock, to fit Soxhlet.
 - 6.4.2.4 Heating mantle—Hemispherical, to fit 500-mL round-bottom flask (Cal-Glass LG-8801-112, or equivalent).
 - 6.4.2.5 Variable transformer—Powerstat (or equivalent), 110-volt, 10-amp.
 - 6.4.3 Beakers—400- to 500-mL.
 - 6.4.4 Spatulas—Stainless steel.
- 6.5 Filtration apparatus.

Method 1668

- 6.5.1 Pyrex glass wool—Solvent-extracted by SDS for 3 hours minimum.
- 6.5.2 Glass funnel—125- to 250-mL.
- 6.5.3 Glass-fiber filter paper—Whatman GF/D (or equivalent), to fit glass funnel in Section 6.5.2.
- 6.5.4 Drying column—15- to 20-mm ID Pyrex chromatographic column equipped with coarse-glass frit or glass-wool plug.
- 6.5.5 Buchner funnel—15-cm.
- 6.5.6 Glass-fiber filter paper for Buchner funnel above.
- 6.5.7 Filtration flasks—1.5- to 2.0-L, with side arm.
- 6.5.8 Pressure filtration apparatus—Millipore YT30 142 HW, or equivalent.
- 6.6 Centrifuge apparatus.
 - 6.6.1 Centrifuge—Capable of rotating 500-mL centrifuge bottles or 15-mL centrifuge tubes at 5,000 rpm minimum.
 - 6.6.2 Centrifuge bottles—500-mL, with screw-caps, to fit centrifuge.
 - 6.6.3 Centrifuge tubes—12- to 15-mL, with screw-caps, to fit centrifuge.
- 6.7 Cleanup apparatus.
 - 6.7.1 Automated gel permeation chromatograph (Analytical Biochemical Labs, Inc, Columbia, MO, Model GPC Autoprep 1002, or equivalent).
 - 6.7.1.1 Column—600-700 mm long × 25 mm ID, packed with 70 g of SX-3 Bio-beads (Bio-Rad Laboratories, Richmond, CA, or equivalent).
 - 6.7.1.2 Syringe—10-mL, with Luer fitting.
 - 6.7.1.3 Syringe filter holder—stainless steel, and glass- fiber or fluoropolymer filters (Gelman 4310, or equivalent).
 - 6.7.1.4 UV detectors—254-nm, preparative or semi-preparative flow cell (Isco, Inc., Type 6; Schmadzu, 5-mm path length; Beckman-Altex 152W, 8- μ L micro-prep flow cell, 2-mm path; Pharmacia UV-1, 3-mm flow cell; LDC Milton-Roy UV-3, monitor #1203; or equivalent).
 - 6.7.2 Reverse-phase high-performance liquid chromatograph.
 - 6.7.2.1 Column oven and detector—Perkin-Elmer Model LC-65T (or equivalent) operated at 0.02 AUFS at 235 nm.
 - 6.7.2.2 Injector—Rheodyne 7120 (or equivalent) with 50- μ L sample loop.
 - 6.7.2.3 Column—Two 6.2 mm × 250 mm Zorbax-ODS columns in series (DuPont Instruments Division, Wilmington, DE, or equivalent), operated at 30°C and 2.0 mL/min with gradient from TBD percent methanol:acetonitrile to 100 percent acetonitrile in TBD minutes.
 - 6.7.2.4 Pump—Altex 110A (or equivalent).
 - 6.7.3 Pipets.
 - 6.7.3.1 Disposable, Pasteur, 150-mm long × 5-mm ID (Fisher Scientific 13-678-6A, or equivalent).

- 6.7.3.2 Disposable, serological, 50-mL (8- to 10- mm ID).
- 6.7.4 Glass chromatographic columns.
- 6.7.4.1 150-mm long × 8-mm ID, (Kontes K-420155, or equivalent) with coarse-glass frit or glass-wool plug and 250-mL reservoir.
- 6.7.4.2 200-mm long × 15-mm ID, with coarse-glass frit or glass-wool plug and 250-mL reservoir.
- 6.7.4.3 300-mm long × 22-mm ID, with coarse-glass frit, 300-mL reservoir, and glass or fluoropolymer stopcock.
- 6.7.5 Stirring apparatus for batch silica cleanup of tissue extracts.
- 6.7.5.1 Mechanical stirrer—Corning Model 320, or equivalent.
- 6.7.5.2 Bottle—500- to 600-mL wide-mouth clear glass.
- 6.7.6 Oven—For baking and storage of adsorbents, capable of maintaining a constant temperature ($\pm 5^{\circ}\text{C}$) in the range of 105-250°C.
- 6.8 Concentration apparatus.
- 6.8.1 Rotary evaporator—Buchi/Brinkman-American Scientific No. E5045-10 or equivalent, equipped with a variable temperature water bath.
- 6.8.1.1 Vacuum source for rotary evaporator equipped with shutoff valve at the evaporator and vacuum gauge.
- 6.8.1.2 A recirculating water pump and chiller are recommended, as use of tap water for cooling the evaporator wastes large volumes of water and can lead to inconsistent performance as water temperatures and pressures vary.
- 6.8.1.3 Round-bottom flask—100-mL and 500-mL or larger, with ground-glass fitting compatible with the rotary evaporator.
- 6.8.2 Kuderna-Danish (K-D) concentrator.
- 6.8.2.1 Concentrator tube—10-mL, graduated (Kontes K-570050-1025, or equivalent) with calibration verified. Ground-glass stopper (size 19/22 joint) is used to prevent evaporation of extracts.
- 6.8.2.2 Evaporation flask—500-mL (Kontes K-570001-0500, or equivalent), attached to concentrator tube with springs (Kontes K-662750-0012 or equivalent).
- 6.8.2.3 Snyder column—Three-ball macro (Kontes K-503000-0232, or equivalent).
- 6.8.2.4 Boiling chips.
- 6.8.2.4.1 Glass or silicon carbide—Approximately 10/40 mesh, extracted with methylene chloride and baked at 450°C for 1 hour minimum.
- 6.8.2.4.2 Fluoropolymer (optional)—Extracted with methylene chloride.
- 6.8.2.5 Water bath—Heated, with concentric ring cover, capable of maintaining a temperature within $\pm 2^{\circ}\text{C}$, installed in a fume hood.
- 6.8.3 Nitrogen blowdown apparatus—Equipped with water bath controlled in the range of 30 - 60°C (N-Evap, Organomation Associates, Inc., South Berlin, MA, or equivalent), installed in a fume hood.

Method 1668

- 6.8.4 Sample vials.
- 6.8.4.1 Amber glass, 2- to 5-mL with fluoropolymer-lined screw-cap.
 - 6.8.4.2 Glass, 0.3-mL, conical, with fluoropolymer-lined screw or crimp cap.
- 6.9 Gas chromatograph—Shall have splitless or on-column injection port for capillary column, temperature program with isothermal hold, and shall meet all of the performance specifications in Section 10.
- 6.9.1 GC columns—The pair of GC columns listed below are capable of resolving all 209 PCB congeners. Other GC columns may be used so long as PCBs 126 and 169 are each resolved from their respective most closely eluted leading and trailing congeners. The valley height between PCB 126 or 169 and its respective most closely eluted leading and trailing congeners must be less than 10 percent of the height of the shorter of the pair.
 - 6.9.2 Column #1— 30 ± 5 -m long \times 0.25 ± 0.02 -mm ID; 0.25 - μ m film SPB-Octyl (Supelco 2-4218, or equivalent).
 - 6.9.3 Column #2— 30 ± 5 -m long \times 0.25 ± 0.02 -mm ID; 0.25 - μ m film DB-1 (J&W, or equivalent).
- 6.10 Mass spectrometer—28- to 40-eV electron impact ionization, shall be capable of repetitively selectively monitoring 12 exact m/z's minimum at high resolution ($\geq 10,000$) during a period less than 1.5 seconds, and shall meet all of the performance specifications in Section 10.
- 6.11 GC/MS interface—The mass spectrometer (MS) shall be interfaced to the GC such that the end of the capillary column terminates within 1 cm of the ion source but does not intercept the electron or ion beams.
- 6.12 Data system—Capable of collecting, recording, and storing MS data.

7.0 Reagents and Standards

- 7.1 pH adjustment and back-extraction.
- 7.1.1 Potassium hydroxide—Dissolve 20 g reagent grade KOH in 100 mL reagent water.
 - 7.1.2 Sulfuric acid—Reagent grade (specific gravity 1.84).
 - 7.1.3 Hydrochloric acid—Reagent grade, 6N.
 - 7.1.4 Sodium chloride—Reagent grade, prepare at 5% (w/v) solution in reagent water.
- 7.2 Solution drying and evaporation.
- 7.2.1 Solution drying—Sodium sulfate, reagent grade, granular, anhydrous (Baker 3375, or equivalent), rinsed with methylene chloride (20 mL/g), baked at 400°C for 1 hour minimum, cooled in a desiccator, and stored in a pre-cleaned glass bottle with screw-cap that prevents moisture from entering. If, after heating, the sodium sulfate develops a noticeable grayish cast (due to the presence of carbon in the crystal matrix), that batch of reagent is not suitable for use and should be discarded. Extraction with methylene chloride (as opposed to simple rinsing) and baking at a lower temperature may produce sodium sulfate that is suitable for use.
 - 7.2.2 Tissue drying—Sodium sulfate, reagent grade, powdered, treated and stored as above.
 - 7.2.3 Purified nitrogen.

7.3 Extraction.

7.3.1 Solvents—Acetone, toluene, n-hexane, methanol, methylene chloride, and nonane; distilled in glass, pesticide quality, lot-certified to be free of interferences.

7.3.2 White quartz sand, 60/70 mesh—For Soxhlet/Dean-Stark extraction (Aldrich Chemical, Cat. No. 27-437-9, or equivalent). Bake at 450°C for 4 hours minimum.

7.4 GPC calibration solution—Prepare a solution containing 300 mg/mL corn oil, TBD mg/mL PCB 209, 1.4 mg/mL pentachlorophenol, 0.1 mg/mL perylene, and 0.5 mg/mL sulfur. [To be modified if necessary.]

7.5 Adsorbents for sample cleanup.**7.5.1 Silica gel.**

7.5.1.1 Activated silica gel—100-200 mesh, Supelco 1-3651 (or equivalent), rinsed with methylene chloride, baked at 180°C for a minimum of 1 hour, cooled in a desiccator, and stored in a precleaned glass bottle with screw-cap that prevents moisture from entering.

7.5.1.2 Acid silica gel (30% w/w)—Thoroughly mix 44.0 g of concentrated sulfuric acid with 100.0 g of activated silica gel in a clean container. Break up aggregates with a stirring rod until a uniform mixture is obtained. Store in a screw-capped bottle with fluoropolymer-lined cap.

7.5.1.3 Basic silica gel—Thoroughly mix 30 g of 1N sodium hydroxide with 100 g of activated silica gel in a clean container. Break up aggregates with a stirring rod until a uniform mixture is obtained. Store in a screw-capped bottle with fluoropolymer-lined cap.

7.5.1.4 Potassium silicate.

7.5.1.4.1 Dissolve 56 g of high purity potassium hydroxide (Aldrich, or equivalent) in 300 mL of methanol in a 750- to 1000-mL flat-bottom flask.

7.5.1.4.2 Add 100 g of activated silica gel (Section 7.5.1.1) and a stirring bar, and stir on a hot plate at 60-70°C for 1-2 hours.

7.5.1.4.3 Decant the liquid and rinse the potassium silicate twice with 100-mL portions of methanol, followed by a single rinse with 100 mL of methylene chloride.

7.5.1.4.4 Spread the potassium silicate on solvent-rinsed aluminum foil and dry for 2-4 hours in a hood.

7.5.1.4.5 Activate overnight at 200-250°C.

7.5.2 Carbon.

7.5.2.1 Carbpak C—(Supelco 1-0258, or equivalent).

7.5.2.2 Celite 545—(Supelco 2-0199, or equivalent).

7.5.2.3 Thoroughly mix 18.0 g Carbpak C and 18.0 g Celite 545 to produce a 50% w/w mixture. Activate the mixture at 130°C for a minimum of 6 hours. Store in a desiccator.

7.5.3 Anthropogenic isolation column—Pack the column in Section 6.7.4.3 from bottom to top with the following:

Method 1668

- 7.5.3.1 2 g activated silica gel (Section 7.5.1.1).
- 7.5.3.2 2 g potassium silicate (Section 7.5.1.4).
- 7.5.3.3 2 g granular anhydrous sodium sulfate (Section 7.2.1).
- 7.5.3.4 10 g acid silica gel (Section 7.5.1.2).
- 7.5.3.5 2 g granular anhydrous sodium sulfate.
- 7.5.4 Florisil column.
 - 7.5.4.1 Florisil—PR grade, 60-100 mesh (U.S. Silica Corp, Berkeley Springs, WV, or equivalent). Fill a clean 1- to 2-L bottle 1/2 to 2/3 full with Florisil and place in an oven at 130-150 °C for a minimum of three days.
 - 7.5.4.2 Immediately prior to use, dry pack a 300-mm x 22-mm ID glass column (Section 6.7.4.3) bottom to top with 0.5-1.0 cm of anhydrous sodium sulfate (Section 7.2.1), 10-10.5 cm of warm to hot activated Florisil (Section 7.5.4.1), and 1-2 cm of warm to hot anhydrous sodium sulfate. Allow the column to cool and wet immediately with 100 mL of n-hexane to prevent water from entering.
 - 7.5.4.3 Using the procedure in Section 13.7, establish the elution pattern for each carton of Florisil received.
- 7.6 Reference matrices—Matrices in which the PCBs and interfering compounds are not detected by this method.
 - 7.6.1 Reagent water—Bottled water purchased locally or prepared by passage through activated carbon.
 - 7.6.2 High-solids reference matrix—Playground sand or similar material. Prepared by extraction with methylene chloride and/or baking at 450°C for a minimum of 4 hours.
 - 7.6.3 Paper reference matrix—Glass-fiber filter, Gelman type A, or equivalent. Cut paper to simulate the surface area of the paper sample being tested.
 - 7.6.4 Tissue reference matrix—Corn or other vegetable oil. May be prepared by extraction with methylene chloride.
 - 7.6.5 Other matrices—This method may be verified on any reference matrix by performing the tests given in Section 9.2. Ideally, the matrix should be free of the PCBs, but in no case shall the background level of the PCBs in the reference matrix exceed three times the minimum levels in Table 2. If low background levels of the PCBs are present in the reference matrix, the spike level of the analytes used in Section 9.2 should be increased to provide a spike-to-background ratio in the range of 1:1 to 5:1 (Reference 11).
- 7.7 Standard solutions—Purchased as solutions or mixtures with certification to their purity, concentration, and authenticity, or prepared from materials of known purity and composition. If the chemical purity is 98% or greater, the weight may be used without correction to compute the concentration of the standard. When not being used, standards are stored in the dark at room temperature in screw-capped vials with fluoropolymer-lined caps. A mark is placed on the vial at the level of the solution so that solvent loss by evaporation can be detected. If solvent loss has occurred, the solution should be replaced.

- 7.8 Stock solutions.**
- 7.8.1** Preparation—Prepare in nonane per the steps below or purchase as dilute solutions (Cambridge Isotope Laboratories (CIL), Woburn, MA, or equivalent). Observe the safety precautions in Section 5 and the recommendation in Section 5.1.2.
- 7.8.2** Dissolve an appropriate amount of assayed reference material in solvent. For example, weigh 1 to 2 mg of PCB 126 to three significant figures in a 10-mL ground-glass-stoppered volumetric flask and fill to the mark with nonane. After the PCB is completely dissolved, transfer the solution to a clean 15-mL vial with fluoropolymer-lined cap.
- 7.8.3** Stock standard solutions should be checked for signs of degradation prior to the preparation of calibration or performance test standards. Reference standards that can be used to determine the accuracy of calibration standards are available from several vendors.
- 7.9 PAR stock solution.**
- 7.9.1** All PCBs—Using the solutions in Section 7.8, prepare the PAR stock solution to contain the PCBs of interest at the concentrations shown in Table 3. When diluted, the solution will become the PAR (Section 7.14).
- 7.9.2** If the toxic, non-ortho, co-planar PCBs (PCBs 77, 126, and 169) only are to be determined, prepare the PAR stock solution to contain these compounds only.
- 7.10 Labeled-compound spiking solution.**
- 7.10.1** All toxic PCBs—From stock solutions, or from purchased mixtures, prepare this solution to contain the labeled compounds in nonane at the concentrations shown in Table 3. This solution is diluted with acetone prior to use (Section 7.10.3).
- 7.10.2** If PCBs 77, 126, and 169 only are to be determined, prepare the labeled-compound solution to contain these compounds only. This solution is diluted with acetone prior to use (Section 7.10.3).
- 7.10.3** Dilute a sufficient volume of the labeled compound solution (Section 7.10.1 or 7.10.2) by a factor of 500 with acetone to prepare a diluted spiking solution. Each sample requires 1.0 mL of the diluted solution, but no more solution should be prepared than can be used in one day.
- 7.11** Cleanup standard—Prepare PCBs 81 and 111 in nonane at the concentration shown in Table 3. The cleanup standard is added to all extracts prior to cleanup to measure the efficiency of the cleanup process.
- 7.12 Internal standard(s).**
- 7.12.1** All toxic PCBs—Prepare the internal standard solution to contain labeled PCBs 52, 101, 138, and 178 in nonane at the concentration shown in Table 3.
- 7.12.2** If PCBs 77, 126, and 169 only are to be determined, the internal standard solution may be prepared to contain PCBs 52, 101, and 138 only.
- 7.13** Calibration standards (CS1 through CS5)—Combine the solutions in Sections 7.9-7.12 to produce the five calibration solutions shown in Table 4 in nonane. These solutions permit the relative response (labeled to native) and response factor to be measured as a function of concentration. The CS3 standard is used for calibration verification (VER). If the PCBs 77, 126, and 169 only are to be determined, combine the solutions appropriate to these compounds.

Method 1668

- 7.14** Precision and recovery (PAR) standard—Used for determination of initial (Section 9.2) and ongoing (Section 15.5) precision and recovery (See Table 3). Dilute 200 µL of the PAR stock solution (Section 7.9.1 or 7.9.2) to 10 mL with acetone for each sample matrix for each sample batch. One mL of each are required for the blank and OPR with each matrix in each batch.
- 7.15** GC retention time window defining solution and isomer specificity test standard—Used to define the beginning and ending retention times for the PCB congeners and to demonstrate isomer specificity of the GC columns employed for determination of PCB 126. The standard must contain the compounds listed in Table 5 (CIL , or equivalent), at a minimum. It is not necessary to monitor all of the window-defining compounds if PCBs 77, 126, and 169 only are to be determined. In this case, a congener-specificity test standard containing the most closely eluted isomers listed in Table 5 (CIL , or equivalent) may be used.
- 7.16** QC Check Sample—A QC Check Sample should be obtained from a source independent of the calibration standards. Ideally, this check sample would be a certified standard reference material (SRM) containing the PCBs in known concentrations in a sample matrix similar to the matrix being analyzed. The National Institute of Standards and Technology (NIST) in Gaithersburg, Maryland has SRMs for several individual PCB congeners, and as Aroclors in transformer and motor oil, in combination with pesticides in cod liver oil, and in combination with 2,3,7,8-TCDD in human serum.
- 7.17** Stability of solutions—Standard solutions used for quantitative purposes (Sections 7.9 through 7.15) should be analyzed periodically, and should be assayed against reference standards before further use.

8.0 Sample Collection, Preservation, Storage, and Holding Times.

- 8.1** Collect samples in amber glass containers following conventional sampling practices (Reference 12).
- 8.2** Aqueous samples.
- 8.2.1** Samples that flow freely are collected as grab samples or in refrigerated bottles using automatic sampling equipment.
- 8.2.2** If residual chlorine is present, add 80 mg sodium thiosulfate per liter of water. EPA Methods 330.4 and 330.5 may be used to measure residual chlorine (Reference 13).
- 8.2.3** Adjust sample pH 2-3 with sulfuric acid.
- 8.2.4** Maintain aqueous samples in the dark at 0-4°C from the time of collection until receipt at the laboratory. Store in the dark at 0-4°C.
- 8.3** Solid samples.
- 8.3.4** Solid samples are collected as grab samples using wide-mouth jars.
- 8.3.4** Maintain solid, semi-solid, oily, and mixed-phase samples in the dark at <4°C from the time of collection until receipt at the laboratory. Store solid, semi-solid, oily, and mixed-phase samples in the dark at <-10°C.
- 8.4** Fish and tissue samples.

- 8.4.1 Fish may be cleaned, filleted, or processed in other ways in the field, such that the laboratory may expect to receive whole fish, fish fillets, or other tissues for analysis.
- 8.4.2 Fish collected in the field should be wrapped in aluminum foil and must be maintained at a temperature less than 4°C from the time of collection until receipt at the laboratory.
- 8.4.3 Samples must be frozen upon receipt at the laboratory and maintained in the dark at <-10°C until prepared. Maintain unused sample in the dark at <-10°C.

8.5 Holding times.

- 8.5.1 There are no demonstrated maximum holding times associated with the PCBs in aqueous, solid, semi-solid, tissues, or other sample matrices. If stored in the dark at 0-4°C and preserved as given above (if required), aqueous samples may be stored for up to one year. Similarly, if stored in the dark at <-10°C, solid, semi-solid, multi-phase, and tissue samples may be stored for up to one year.
- 8.5.2 Store sample extracts in the dark at <-10°C until analyzed. If stored in the dark at <-10°C, sample extracts may be stored for up to one year.

9.0 Quality Assurance/Quality Control

- 9.1 Each laboratory that uses this method is required to operate a formal quality assurance program (Reference 14). The minimum requirements of this program consist of an initial demonstration of laboratory capability, analysis of samples spiked with labeled compounds to evaluate and document data quality, and analysis of standards and blanks as tests of continued performance. Laboratory performance is compared to established performance criteria to determine if the results of analyses meet the performance characteristics of the method.

If the method is to be applied to a sample matrix other than water (e.g., soils, filter cake, compost, tissue) the most appropriate alternate matrix (Sections 7.6.2-7.6.5 and 7.16) is substituted for the reagent water matrix (Section 7.6.1) in all performance tests.

- 9.1.1 The analyst shall make an initial demonstration of the ability to generate acceptable accuracy and precision with this method. This ability is established as described in Section 9.2.
- 9.1.2 In recognition of advances that are occurring in analytical technology and to allow the analyst to overcome sample matrix interferences, the analyst is permitted certain options to improve separations or lower the costs of measurements. These options include alternate extraction, concentration, cleanup procedures, and changes in columns and detectors. Alternate determinative techniques, such as the substitution of spectroscopic or immunoassay techniques, and changes that degrade method performance, are not allowed. If an analytical technique other than the techniques specified in this method is used, that technique must have a specificity equal to or better than the specificity of the techniques in this method for the analytes of interest.
 - 9.1.2.1 Each time a modification is made to this method, the analyst is required to repeat the procedure in Section 9.2. If the detection limit of the method will be affected by the change, the laboratory is required to demonstrate that the MDL (40 CFR Part 136, Appendix B) is lower than one-third the regulatory compliance level or one-third the

Method 1668

ML in this method, whichever is higher. If calibration will be affected by the change, the analyst must recalibrate the instrument per Section 10.

9.1.2.2 The laboratory is required to maintain records of modifications made to this method. These records include the following at a minimum:

9.1.2.2.1 The names, titles, addresses, and telephone numbers of the analyst(s) who performed the analyses and modification, and of the quality control officer who witnessed and will verify the analyses and modifications.

9.1.2.2.2 A listing of pollutant(s) measured, by name and CAS Registry number.

9.1.2.2.3 A narrative stating reason(s) for the modifications.

9.1.2.2.4 Results from all quality control (QC) tests comparing the modified method to this method. These results are to include the following:

- a) Calibration (Section 10.5-10.7).
- b) Calibration verification (Section 15.3).
- c) Initial precision and recovery (Section 9.2).
- d) Labeled compound recovery (Section 9.3).
- e) Analysis of blanks (Section 9.5).
- f) Accuracy assessment (Section 9.4).

9.1.2.2.5 Data that will allow an independent reviewer to validate each determination by tracing the instrument output (peak height, area, or other signal) to the final result. These data are to include the following:

- a) Sample numbers and other identifiers.
- b) Extraction dates.
- c) Analysis dates and times.
- d) Analysis sequence/run chronology.
- e) Sample weight or volume (Section 11).
- f) Extract volume prior to each cleanup step (Section 13).
- g) Extract volume after each cleanup step (Section 13).
- h) Final extract volume prior to injection (Section 14).
- i) Injection volume (Section 14.3).
- j) Dilution data, differentiating between dilution of a sample or extract (Section 17.5).
- k) Instrument and operating conditions.
- l) Column (dimensions, liquid phase, solid support, film thickness, etc).
- m) Operating conditions (temperatures, temperature program, flow rates).
- n) Detector (type, operating conditions, etc).
- o) Chromatograms, printer tapes, and other recordings of raw data.
- p) Quantitation reports, data system outputs, and other data to link the raw data to the results reported.

9.1.3 Analyses of method blanks are required to demonstrate freedom from contamination (Section 4.3). The procedures and criteria for analysis of a method blank are described in Sections 9.5 and 15.6.

9.1.4 The laboratory shall spike all samples with labeled compounds to monitor method performance. This test is described in Section 9.3. When results of these spikes indicate

- atypical method performance for samples, the samples are diluted to bring method performance within acceptable limits. Procedures for dilution are given in Section 17.5.
- 9.1.5** The laboratory shall, on an ongoing basis, demonstrate through calibration verification and the analysis of the ongoing precision and recovery aliquot that the analytical system is in control. These procedures are described in Sections 15.1 through 15.5.
- 9.1.6** The laboratory shall maintain records to define the quality of data that is generated. Development of accuracy statements is described in Section 9.4.
- 9.2** Initial precision and recovery (IPR)—To establish the ability to generate acceptable precision and recovery, the analyst shall perform the following operations.
- 9.2.1** For low solids (aqueous, < 1% solids) samples, extract, concentrate, and analyze four 1-L aliquots of reagent water spiked with the diluted labeled compound spiking solution (Section 7.10.3) and the precision and recovery standard (Section 7.14) according to the procedures in Sections 11 through 18. For an alternative sample matrix, four aliquots of the alternative reference matrix (Section 7.6) are used. All sample processing steps that are to be used for processing samples, including preparation (Section 11), extraction (Section 12), and cleanup (Section 13), shall be included in this test.
- 9.2.2** Using results of the set of four analyses, compute the average concentration (X) of the extracts in ng/mL and the standard deviation of the concentration (s) in ng/mL for each compound, by isotope dilution for PCBs with a labeled analog, and by internal standard for the PCBs without a labeled analog, and the labeled compounds.
- 9.2.3** For each PCB and labeled compound, compare s and X with the corresponding limits for initial precision and recovery in Table 6. If PCBs 77, 126, and 169 only are to be determined, compare s and X with the corresponding limits for initial precision and recovery in Table 6a. If s and X for all compounds meet the acceptance criteria, system performance is acceptable and analysis of blanks and samples may begin. If, however, any individual s exceeds the precision limit or any individual X falls outside the range for accuracy, system performance is unacceptable for that compound. Correct the problem and repeat the test (Section 9.2).
- 9.3** The laboratory shall spike all samples with the diluted labeled compound spiking solution (Section 7.10.3) to assess method performance on the sample matrix.
- 9.3.1** Analyze each sample according to the procedures in Sections 11 through 18.
- 9.3.2** Compute the percent recovery of the labeled compounds and the cleanup standard using the internal standard method (Section 17.2).
- 9.3.3** The recovery of each labeled compound must be within the limits in Table 7 when all of the toxic PCBs are determined, and within the limits in Table 7a when PCBs 77, 126, and 169 only are determined. If the recovery of any compound falls outside of these limits, method performance is unacceptable for that compound in that sample. Additional cleanup procedures must then be employed to attempt to bring the recovery within the normal range. If the recovery cannot be brought within the normal range after all cleanup procedures have been employed, water samples are diluted and smaller amounts of soils, sludges, sediments, and other matrices are analyzed per Section 18.4.

Method 1668

- 9.4** Recovery of labeled compounds from samples should be assessed and records should be maintained.
- 9.4.1** After the analysis of five samples of a given matrix type (water, soil, sludge, pulp, etc.) for which the labeled compounds pass the tests in Section 9.3, compute the average percent recovery (R) and the standard deviation of the percent recovery (S_R) for the labeled compounds only. Express the assessment as a percent recovery interval from $R - 2S_R$ to $R + 2S_R$ for each matrix. For example, if $R = 90\%$ and $S_R = 10\%$ for five analyses of pulp, the recovery interval is expressed as 70 to 110%.
- 9.4.2** Update the accuracy assessment for each labeled compound in each matrix on a regular basis (e.g., after each five to ten new measurements).
- 9.5** Method blanks—Reference matrix method blanks are analyzed to demonstrate freedom from contamination (Section 4.3).
- 9.5.1** Prepare, extract, clean up, and concentrate a method blank with each sample batch (samples of the same matrix started through the extraction process on the same 12-hour shift, to a maximum of 20 samples). The matrix for the method blank shall be similar to sample matrix for the batch; e.g., a 1-L reagent water blank (Section 7.6.1), high-solids reference matrix blank (Section 7.6.2), paper matrix blank (Section 7.6.3), tissue blank (Section 7.6.4), or alternative reference matrix blank (Section 7.6.5). Analyze the blank immediately after analysis of the OPR (Section 15.5) to demonstrate freedom from contamination.
- 9.5.2** If any PCB (Table 1) is found in the blank at greater than the minimum level (Table 2) or one-third the regulatory compliance level whichever is greater, or if any potentially interfering compound is found in the blank at the minimum level for each level of chlorination given in Table 2 (assuming a response factor of 1 relative to the internal standard at that level of chlorination for compounds not listed in Table 1), analysis of samples is halted until the blank associated with the sample batch shows no evidence of contamination at this level. All samples must be associated with an uncontaminated method blank before the results for those samples may be reported for regulatory compliance purposes.
- 9.6** QC Check Sample—Analyze the QC Check Sample (Section 7.16) periodically to assure the accuracy of calibration standards and the overall reliability of the analytical process. It is suggested that the QC Check Sample be analyzed at least quarterly.
- 9.7** The specifications contained in this method can be met if the apparatus used is calibrated properly and then maintained in a calibrated state. The standards used for calibration (Section 10), calibration verification (Section 15.3), and for initial (Section 9.2) and ongoing (Section 15.5) precision and recovery should be identical, so that the most precise results will be obtained. A GC/MS instrument will provide the most reproducible results if dedicated to the settings and conditions required for the analyses of PCBs by this method.
- 9.8** Depending on specific program requirements, field replicates may be collected to determine the precision of the sampling technique, and spiked samples may be required to determine the accuracy of the analysis when the internal standard method is used.

10.0 Calibration

10.1 Establish the operating conditions necessary to meet the minimum retention times for the internal standards in Section 10.2.4 and the relative retention times for the PCBs in Table 2.

10.1.1 Suggested GC operating conditions:

Injector temperature:	290°C
Interface temperature:	290°C
Initial temperature:	150°C
Initial time:	2 minutes
Temperature program:	150 to 200°C at 10°C/minute 200 to 280°C at 2.0°C/minute

Note: *All portions of the column that connect the GC to the ion source shall remain at or above the interface temperature specified above during analysis to preclude condensation of less volatile compounds.*

The GC conditions may be optimized for compound separation and sensitivity. Once optimized, the same GC conditions must be used for the analysis of all standards, blanks, IPR and OPR aliquots, and samples.

10.1.2 Mass spectrometer (MS) resolution—Obtain a selected ion current profile (SICP) of each analyte in Table 3 at the two exact m/z 's specified in Table 8 and at $\geq 10,000$ resolving power by injecting an authentic standard of the PCBs either singly or as part of a mixture in which there is no interference between closely eluted components.

10.1.2.1 The analysis time for PCBs may exceed the long-term mass stability of the mass spectrometer. Because the instrument is operated in the high-resolution mode, mass drifts of a few ppm (e.g., 5 ppm in mass) can have serious adverse effects on instrument performance. Therefore, a mass-drift correction is mandatory and a lock-mass m/z from PFK is used for drift correction. The lock-mass m/z is dependent on the exact m/z 's monitored within each descriptor, as shown in Table 8. The level of PFK metered into the HRMS during analyses should be adjusted so that the amplitude of the most intense selected lock-mass m/z signal (regardless of the descriptor number) does not exceed 10% of the full-scale deflection for a given set of detector parameters. Under those conditions, sensitivity changes that might occur during the analysis can be more effectively monitored.

Note: *Excessive PFK (or any other reference substance) may cause noise problems and contamination of the ion source necessitating increased frequency of source cleaning.*

10.1.2.2 If the HRMS has the capability to monitor resolution during the analysis, it is acceptable to terminate the analysis when the resolution falls below 10,000 to save reanalysis time.

Method 1668

- 10.1.2.3** Using a PFK molecular leak, tune the instrument to meet the minimum required resolving power of 10,000 (10% valley) at m/z 304.9824 or any other reference signal close to m/z 305 (from PeCB). For each descriptor (Table 8), monitor and record the resolution and exact m/z 's of three to five reference peaks covering the mass range of the descriptor. The resolution must be greater than or equal to 10,000, and the deviation between the exact m/z and the theoretical m/z (Table 8) for each exact m/z monitored must be less than 5 ppm.
- 10.2** Ion abundance ratios, minimum levels, signal-to-noise ratios, and absolute retention times— Choose an injection volume of either 1- or 2- μ L, consistent with the capability of the HRGC/HRMS instrument. Inject a 1 or 2 μ L aliquot of the CS1 calibration solution (Table 4) using the GC conditions from Section 10.1.1. If PCBs 77, 126, and 169 only are to be determined, the operating conditions and specifications below apply to analysis of those compounds only.
- 10.2.1** Measure the SICP areas for each analyte, and compute the ion abundance ratios at the exact m/z 's specified in Table 8. Compare the computed ratio to the theoretical ratio given in Table 9.
- 10.2.1.1** The exact m/z 's to be monitored in each descriptor are shown in Table 8. Each group or descriptor shall be monitored in succession as a function of GC retention time to ensure that all of the toxic PCBs are detected. Additional m/z 's may be monitored in each descriptor, and the m/z 's may be divided among more than the descriptors listed in Table 8, provided that the laboratory is able to monitor the m/z 's of all the PCBs that may elute from the GC in a given retention-time window. If PCBs 77, 126, and 169 only are to be determined, the descriptors may be modified to include only the exact m/z 's for the tetra-, penta-, and hexa-, congeners, and the lock m/z 's.
- 10.2.1.2** The mass spectrometer shall be operated in a mass-drift correction mode, using PFK to provide lock m/z 's. The lock mass for each group of m/z 's is shown in Table 8. Each lock mass shall be monitored and shall not vary by more than $\pm 20\%$ throughout its respective retention time window. Variations of the lock mass by more than 20% indicate the presence of coeluting interferences that may significantly reduce the sensitivity of the mass spectrometer. Reinjection of another aliquot of the sample extract will not resolve the problem. Additional cleanup of the extract may be required to remove the interferences.
- 10.2.2** All PCBs and labeled compounds in the CS1 standard shall be within the QC limits in Table 9 for their respective ion abundance ratios; otherwise, the mass spectrometer shall be adjusted and this test repeated until the m/z ratios fall within the limits specified. If the adjustment alters the resolution of the mass spectrometer, resolution shall be verified (Section 10.1.2) prior to repeat of the test.
- 10.2.3** Verify that the HRGC/HRMS instrument meets the minimum levels in Table 2. The peaks representing the PCBs and labeled compounds in the CS1 calibration standard must have signal-to-noise ratios (S/N) greater than or equal to 10.0. Otherwise, the mass spectrometer shall be adjusted and this test repeated until the minimum levels in Table 2 are met.

- 10.2.4** The absolute retention time of PCB 169 (Section 7.12) shall exceed 20 minutes on the SPB-Octyl column, and the retention time of PCB 157 shall exceed 25 minutes on the DB-1 column; otherwise, the GC temperature program shall be adjusted and this test repeated until the above-stated minimum retention time criteria are met.
- 10.3** Retention-time windows—Analyze the window defining mixtures (Section 7.15) using the optimized temperature program in Section 10.1. Table 5 gives the elution order (first/last) of the window-defining compounds. If PCBs 77, 126, and 169 only are to be determined, the window-defining tetra-, penta-, and hepta-PCBs are the only compounds that need to be tested.
- 10.4** Isomer specificity.
- 10.4.1** Analyze the isomer specificity test standards (Section 7.15) using the procedure in Section 14 and the optimized conditions for sample analysis (Section 10.1.1).
- 10.4.2** Compute the percent valley between the GC peaks that elute most closely to PCB 126 and 169 on the SPB-Octyl column and to PCB 156/157 on the DB-1 column, per Figures 6 and 7.
- 10.4.3** Verify that the height of the valley between the most closely eluted isomers and the PCBs given in Section 10.4.2 is less than 25% (computed as $100 \times y$ in Figures 6 and 7). If the valley exceeds 25%, adjust the analytical conditions and repeat the test or replace the GC column and recalibrate (Sections 10.1.2 through 10.7).
- 10.5** Calibration by isotope dilution—Isotope dilution calibration is used for the native PCBs for which labeled compounds are added to samples prior to extraction. The reference compound for each native compound is shown in Table 2.
- 10.5.1** A calibration curve encompassing the concentration range is prepared for each compound to be determined. The relative response (RR) (labeled to native) vs. concentration in standard solutions is plotted or computed using a linear regression. Relative response is determined according to the procedures described below. Five calibration points are employed.
- 10.5.2** The response of each native PCB relative to its labeled analog is determined using the area responses of both the primary and secondary exact m/z 's specified in Table 8, for each calibration standard as follows:

$$RR = \frac{(A1_n + A2_n) C_l}{(A1_l + A2_l) C_n}$$

Where:

$A1_n$ and $A2_n$ = The areas of the primary and secondary m/z 's for the PCB.

$A1_l$ and $A2_l$ = The areas of the primary and secondary m/z 's for the labeled compound.

C_l = The concentration of the labeled compound in the calibration standard (Table 4).

C_n = The concentration of the native compound in the calibration standard (Table 4).

- 10.5.3** To calibrate the analytical system by isotope dilution, inject a volume of calibration standards CS1 through CS5 (Section 7.13 and Table 4) identical to the volume chosen in

Method 1668

Section 10.2, using the procedure in Section 14 and the conditions in Section 10.1.1 and Table 2. Compute the relative response (RR) at each concentration.

- 10.5.4** Linearity—If the relative response for any compound is constant (less than 20% coefficient of variation) over the five-point calibration range, an averaged relative response may be used for that compound; otherwise, the complete calibration curve for that compound shall be used over the five-point calibration range.
- 10.6** Calibration by internal standard—The internal standard method is applied to determination of the native PCBs for which a labeled compound is not available and to the determination of labeled compounds for intralaboratory statistics (Sections 9.4 and 15.5.4).
- 10.6.1** Response factors—Calibration requires the determination of response factors (RF) defined by the following equation:

$$RF = \frac{(A1_s + A2_s) C_{is}}{(A1_{is} + A2_{is}) C_s}$$

Where:

- $A1_s$ and $A2_s$ = The areas of the primary and secondary m/z's for the PCB.
 $A1_{is}$ and $A2_{is}$ = The areas of the primary and secondary m/z's for the internal standard.
 C_{is} = The concentration of the internal standard (Table 4).
 C_s = The concentration of the compound in the calibration standard (Table 4).

Note: *There is only one m/z for PCBs 81 and 111 (see Table 8).*

- 10.6.2** To calibrate the analytical system by internal standard, inject 1.0 or 2.0 μ L of calibration standards CS1 through CS5 (Section 7.13 and Table 4) using the procedure in Section 14 and the conditions in Section 10.1.1 and Table 2. Compute the response factor (RF) at each concentration.
- 10.6.3** Linearity—If the response factor (RF) for any compound is constant (less than 35% coefficient of variation) over the five-point calibration range, an averaged response factor may be used for that compound; otherwise, the complete calibration curve for that compound shall be used over the five-point range.
- 10.7** Combined calibration—By using calibration solutions (Section 7.13 and Table 4) containing the native PCBs, labeled compounds, and the internal standards, a single set of analyses can be used to produce calibration curves for the isotope dilution and internal standard methods. These curves are verified (Section 15.3) each shift by analyzing the calibration verification standard (VER, Table 4). Recalibration is required if any of the calibration verification criteria (Section 15.3) cannot be met.
- 10.8** Data storage—MS data shall be collected, recorded, and stored.
- 10.8.1** Data acquisition—The signal at each exact m/z shall be collected repetitively throughout the monitoring period and stored on a mass storage device.
- 10.8.2** Response factors and multipoint calibrations—The data system shall be used to record and maintain lists of response factors (response ratios for isotope dilution) and multipoint

calibration curves. Computations of relative standard deviation (coefficient of variation) shall be used to test calibration linearity. Statistics on initial performance (Section 9.2) and ongoing performance (Section 15.5) should be computed and maintained, either on the instrument data system or on a separate computer system.

11.0 Sample Preparation

11.1 Sample preparation involves modifying the physical form of the sample so that the PCBs can be extracted efficiently. In general, the samples must be in a liquid form or in the form of finely divided solids in order for efficient extraction to take place. Table 10 lists the phases and suggested quantities for extraction of various sample matrices.

For samples known or expected to contain high levels of the PCBs, the smallest sample size representative of the entire sample should be used (see Section 17.5).

For all samples, the blank and IPR/OPR aliquots must be processed through the same steps as the sample to check for contamination and losses in the preparation processes.

11.1.1 For samples that contain particles, percent solids and particle size are determined using the procedures in Sections 11.2 and 11.3, respectively.

11.1.2 Aqueous samples—Because PCBs may be bound to suspended particles, the preparation of aqueous samples is dependent on the solids content of the sample.

11.1.2.1 Aqueous samples containing 1% solids or less are prepared per Section 11.4 and extracted directly using the SPE technique in 12.2.

11.1.2.2 For aqueous samples containing greater than 1% solids, a sample aliquot sufficient to provide 10 g of dry solids is used as described in Section 11.5.

11.1.3 Solid samples are prepared using the procedure described in Section 11.5 followed by extraction via the SDS procedure in Section 12.3.

11.1.4 Multiphase samples—The phase(s) containing the PCBs is separated from the non-PCB phase using pressure filtration and centrifugation as described in Section 11.6. The PCBs will be in the organic phase in a multiphase sample in which an organic phase exists.

11.1.5 Procedures for grinding, homogenization, and blending of various sample phases are given in Section 11.7.

11.1.6 Tissue samples—Preparation procedures for fish and other tissues are given in Section 11.8.

11.2 Determination of percent suspended solids.

Note: *This aliquot is used for determining the solids content of the sample, not for determination of PCBs.*

11.2.1 Aqueous liquids and multi-phase samples consisting of mainly an aqueous phase.

11.2.1.1 Desiccate and weigh a GF/D filter (Section 6.5.3) to three significant figures.

11.2.1.2 Filter 10.0 ± 0.02 mL of well-mixed sample through the filter.

11.2.1.3 Dry the filter a minimum of 12 hours at 110 ± 5°C and cool in a desiccator.

Method 1668

11.2.1.4 Calculate percent solids as follows:

$$\% \text{ solids} = \frac{\text{weight of sample aliquot plus filter after drying (g)} - \text{weight of filter (g)}}{10 \text{ g}} \times 100$$

11.2.2 Non-aqueous liquids, solids, semi-solid samples, and multi-phase samples in which the main phase is not aqueous, but not tissues.

11.2.2.1 Weigh 5 to 10 g of sample to three significant figures in a tared beaker.

11.2.2.2 Dry a minimum of 12 hours at $110 \pm 5^\circ\text{C}$, and cool in a desiccator.

11.2.2.3 Calculate percent solids as follows:

$$\% \text{ solids} = \frac{\text{weight of sample aliquot after drying}}{\text{weight of sample aliquot before drying}} \times 100$$

11.3 Determination of particle size.

11.3.1 Spread the dried sample from Section 11.2.2.2 on a piece of filter paper or aluminum foil in a fume hood or glove box.

11.3.2 Estimate the size of the particles in the sample. If the size of the largest particles is greater than 1 mm, the particle size must be reduced to 1 mm or less prior to extraction using the procedures in Section 11.7.

11.4 Preparation of aqueous samples containing 1% suspended solids or less.

11.4.1 Aqueous samples containing 1% suspended solids or less are prepared using the procedure below and extracted using the SPE technique in Section 12.2.

11.4.2 Preparation of sample and QC aliquots.

11.4.2.1 Mark the original level of the sample on the sample bottle for reference. Weigh the sample-plus bottle to ± 1 g.

11.4.2.2 Spike 1.0 mL of the diluted labeled-compound spiking solution (Section 7.10.3) into the sample bottle. Cap the bottle and mix the sample by careful shaking. Allow the sample to equilibrate for 1 to 2 hours, with occasional shaking.

11.4.2.3 For each sample or sample batch (to a maximum of 20 samples) to be extracted during the same 12-hour shift, place two 1.0-L aliquots of reagent water in clean sample bottles or flasks.

11.4.2.4 Spike 1.0 mL of the diluted labeled-compound spiking solution (Section 7.10.3) into both reagent water aliquots. One of these aliquots will serve as the method blank.

11.4.2.5 Spike 1.0 mL of the PAR standard (Section 7.14) into the remaining reagent water aliquot. This aliquot will serve as the OPR (Section 15.5).

11.4.2.6 Add 5 mL of methanol to the sample and QC aliquots. Cap and shake the sample and QC aliquots to mix thoroughly and proceed to Section 12.2 for extraction.

- 11.5** Preparation of samples containing greater than 1% solids.
- 11.5.1** Weigh a well-mixed aliquot of each sample (of the same matrix type) sufficient to provide 10 g of dry solids (based on the solids determination in Section 11.2) into a clean beaker or glass jar.
 - 11.5.2** Spike 1.0 mL of the diluted labeled compound spiking solution (Section 7.10.3) into the sample.
 - 11.5.3** For each sample or sample batch (to a maximum of 20 samples) to be extracted during the same 12 hour shift, weigh two 10-g aliquots of the appropriate reference matrix (Section 7.6) into clean beakers or glass jars.
 - 11.5.4** Spike 1.0 mL of the diluted labeled compound spiking solution (Section 7.10.3) into each reference matrix aliquot. One aliquot will serve as the method blank. Spike 1.0 mL of the PAR standard (Section 7.14) into the other reference matrix aliquot. This aliquot will serve as the OPR (Section 15.5).
 - 11.5.5** Stir or tumble and equilibrate the aliquots for 1 to 2 hours.
 - 11.5.6** Decant excess water. If necessary to remove water, filter the sample through a glass-fiber filter (Section 6.5.6) and discard the aqueous liquid.
 - 11.5.7** If particles >1 mm are present in the sample (as determined in Section 11.3.2), spread the sample on clean aluminum foil in a hood. After the sample is dry, grind to reduce the particle size (Section 11.7).
 - 11.5.8** Extract the sample and QC aliquots using the SDS procedure in Section 12.3.
- 11.6** Multiphase samples.
- 11.6.1** Using the percent solids determined in Section 11.2.1 or 11.2.2, determine the volume of sample that will provide 10 g of solids, up to 1 L of sample.
 - 11.6.2** Pressure filter the amount of sample determined in Section 11.6.1 through Whatman GF/D glass-fiber filter paper (Section 6.5.3). Pressure filter the blank and OPR aliquots through GF/D papers also. If necessary to separate the phases and/or settle the solids, centrifuge these aliquots prior to filtration.
 - 11.6.3** Discard any aqueous phase (if present). Remove any non-aqueous liquid present and reserve the maximum amount filtered from the sample (Section 11.6.1) or 10 g, whichever is less, for combination with the solid phase (Section 12.3.5).
 - 11.6.4** If particles >1 mm are present in the sample (as determined in Section 11.3.2) and the sample is capable of being dried, spread the sample and QC aliquots on clean aluminum foil in a hood. After the aliquots are dry, or if the sample cannot be dried, reduce the particle size using the procedures in Section 11.7 and extract the reduced particles using the SDS procedure in Section 12.3. If particles >1 mm are not present, extract the particles and filter in the sample and QC aliquots directly using the SDS procedure in Section 12.3.
- 11.7** Sample grinding, homogenization, or blending—Samples with particle sizes greater than 1 mm (as determined in Section 11.3.2) are subjected to grinding, homogenization, or blending. The method of reducing particle size to less than 1 mm is matrix-dependent. In general, hard particles can be reduced by grinding with a mortar and pestle. Softer particles can be reduced by grinding in a Wiley mill or meat grinder, by homogenization, or in a blender.

Method 1668

- 11.7.1 Each size-reducing preparation procedure on each matrix shall be verified by running the tests in Section 9.2 before the procedure is employed routinely.
- 11.7.2 The grinding, homogenization, or blending procedures shall be carried out in a glove box or fume hood to prevent particles from contaminating the work environment.
- 11.7.3 Grinding—Certain papers and pulps, slurries, and amorphous solids can be ground in a Wiley mill or heavy duty meat grinder. In some cases, reducing the temperature of the sample to freezing or to dry ice or liquid nitrogen temperatures can aid in the grinding process. Grind the sample aliquots from Sections 11.5.7 or 11.6.4 in a clean grinder. Do not allow the sample temperature to exceed 50°C. Grind the blank and reference matrix aliquots using a clean grinder.
- 11.7.4 Homogenization or blending—Particles that are not ground effectively, or particles greater than 1 mm in size after grinding, can often be reduced in size by high speed homogenization or blending. Homogenize and/or blend the particles or filter from Sections 11.5.7 or 11.6.4 for the sample, blank, and OPR aliquots.
- 11.7.5 Extract the aliquots using the SDS procedure in Section 12.3.
- 11.8 Fish and other tissues—Prior to processing tissue samples, the laboratory must determine the exact tissue to be analyzed. Common requests for analysis of fish tissue include whole fish—skin on, whole fish—skin removed, edible fish fillets (filleted in the field or by the laboratory), specific organs, and other portions. Once the appropriate tissue has been determined, the sample must be homogenized.
- 11.8.1 Homogenization.
- 11.8.1.1 Samples are homogenized while still frozen, where practical. If the laboratory must dissect the whole fish to obtain the appropriate tissue for analysis, the unused tissues may be rapidly refrozen and stored in a clean glass jar for subsequent use.
- 11.8.1.2 Each analysis requires 10 g of tissue (wet weight). Therefore, the laboratory should homogenize at least 20 g of tissue to allow for re-extraction of a second aliquot of the same homogenized sample, if re-analysis is required. When whole fish analysis is necessary, the entire fish is homogenized.
- 11.8.1.3 Homogenize the sample in a tissue homogenizer (Section 6.3.3) or grind in a meat grinder (Section 6.3.4). Cut tissue too large to feed into the grinder into smaller pieces. To assure homogeneity, grind three times.
- 11.8.1.4 Transfer approximately 10 g (wet weight) of homogenized tissue to a clean, tared, 400- to 500-mL beaker.
- 11.8.1.5 Transfer the remaining homogenized tissue to a clean jar with a fluoropolymer-lined lid. Seal the jar and store the tissue at <-10°C. Return any tissue that was not homogenized to its original container and store at <-10°C.
- 11.8.2 QC aliquots.
- 11.8.2.1 Prepare a method blank by adding approximately 10 g of the oily liquid reference matrix (Section 7.6.4) to a 400- to 500-mL beaker.
- 11.8.2.2 Prepare a precision and recovery aliquot by adding approximately 10 g of the oily liquid reference matrix (Section 7.6.4) to a separate 400- to 500-mL beaker. Record

the weight to the nearest 10 mg. If the initial precision and recovery test is to be performed, use four aliquots; if the ongoing precision and recovery test is to be performed, use a single aliquot.

11.8.3 Spiking.

11.8.3.1 Spike 1.0 mL of the labeled compound spiking solution (Section 7.10.3) into the sample, blank, and OPR aliquot.

11.8.3.2 Spike 1.0 mL of the PAR standard (Section 7.14) into the OPR aliquot.

11.8.4 Extract the aliquots using the procedures in Section 12.4.

12.0 Extraction and Concentration

12.1 Extraction procedures include solid phase (Section 12.2) for aqueous liquids; Soxhlet/Dean-Stark (Section 12.3) for solids and filters; and Soxhlet extraction (Section 12.4) for tissues. Acid/base back-extraction (Section 12.5) is used for initial cleanup of extracts.

Macro-concentration procedures include rotary evaporation (Section 12.6.1), heating mantle (Section 12.6.2), and Kuderna-Danish (K-D) evaporation (Section 12.6.3). Micro-concentration uses nitrogen blowdown (Section 12.7).

12.2 SPE of samples containing less than 1% solids.

12.2.1 Disk preparation.

12.2.1.1 Remove the test tube from the suction flask (Figure 4). Place an SPE disk on the base of the filter holder and wet with methylene chloride. While holding a GMF 150 filter above the SPE disk with tweezers, wet the filter with methylene chloride and lay the filter on the SPE disk, making sure that air is not trapped between the filter and disk. Clamp the filter and SPE disk between the 1-L glass reservoir and the vacuum filtration flask.

12.2.1.2 Rinse the sides of the reservoir with approximately 15 mL of methylene chloride using a squeeze bottle or pipet. Apply vacuum momentarily until a few drops appear at the drip tip. Release the vacuum and allow the filter/disk to soak for approximately one minute. Apply vacuum and draw all of the methylene chloride through the filter/disk. Repeat the wash step with approximately 15 mL of acetone and allow the filter/disk to air dry.

12.2.2 Sample extraction.

12.2.2.1 Pre-wet the disk by adding approximately 20 mL of methanol to the reservoir. Pull most of the methanol through the filter/disk, retaining a layer of methanol approximately 2 mm thick on the filter. Do not allow the filter/disk to go dry from this point until the extraction is completed.

12.2.2.2 Add approximately 20 mL of reagent water to the reservoir and pull most through, leaving a layer approximately 2 mm thick on the filter/disk.

12.2.2.3 Allow the sample (Section 11.4.2.2) to stand for 1-2 hours, if necessary, to settle the suspended particles. Decant the clear layer of the sample, the blank (Section 11.4.2.4), or IPR/OPR aliquot (Section 11.4.2.5) into the reservoir and turn on the vacuum to begin the extraction. Adjust the vacuum to complete the extraction in no less than 10

Method 1668

minutes. For samples containing a high concentration of particles (suspended solids), the extraction time may be one hour or longer.

- 12.2.2.4 Before all of the sample has been pulled through the filter/disk, add approximately 50 mL of reagent water to the sample bottle, swirl to suspend the solids (if present), and pour into the reservoir. Pull through the filter/disk. Use additional reagent water rinses until all solids are removed.
- 12.2.2.5 Before all of the sample and rinses have been pulled through the filter/disk, rinse the sides of the reservoir with small portions of reagent water.
- 12.2.2.6 Partially dry the filter/disk under vacuum for approximately 3 minutes.

12.2.3 Elution of the filter/disk.

- 12.2.3.1 Release the vacuum, remove the entire filter/disk/reservoir assembly from the vacuum flask, and empty the flask. Insert a test tube for eluant collection into the flask. The test tube should have sufficient capacity to contain the total volume of the elution solvent (approximately 50 mL) and should fit around the drip tip. The drip tip should protrude into the test tube to preclude loss of sample from spattering when vacuum is applied. Reassemble the filter/disk/reservoir assembly on the vacuum flask.
- 12.2.3.2 Wet the filter/disk with 4-5 mL of acetone. Allow the acetone to spread evenly across the disk and soak for 15-20 seconds. Pull the acetone through the disk, releasing the vacuum when approximately 1 mm thickness remains on the filter.
- 12.2.3.3 Rinse the sample bottle with approximately 20 mL of methylene chloride and transfer to the reservoir. Pull approximately half of the solvent through the filter/disk and release the vacuum. Allow the filter/disk to soak for approximately 1 minute. Pull all of the solvent through the disk. Repeat the bottle rinsing and elution step with another 20 mL of methylene chloride. Pull all of the solvent through the disk.
- 12.2.3.4 Release the vacuum, remove the filter/disk/reservoir assembly, and remove the test tube containing the sample solution. Quantitatively transfer the solution to a 250-mL separatory funnel and proceed to Section 12.5 for back-extraction.

12.3 SDS extraction of samples containing particles.

- 12.3.1 Charge a clean extraction thimble (Section 6.4.2.2) with 5.0 g of 100/200 mesh silica (Section 7.5.1.1) topped with 100 g of quartz sand (Section 7.3.2).

Note: *Do not disturb the silica layer throughout the extraction process.*

- 12.3.2 Place the thimble in a clean extractor. Place 30 to 40 mL of toluene in the receiver and 200 to 250 mL of toluene in the flask.
- 12.3.3 Pre-extract the glassware by heating the flask until the toluene is boiling. When properly adjusted, 1 to 2 drops of toluene will fall per second from the condenser tip into the receiver. Extract the apparatus for a minimum of 3 hours.
- 12.3.4 After pre-extraction, cool and disassemble the apparatus. Rinse the thimble with toluene and allow to air dry.

- 12.3.5** Load the wet sample and/or filter from Sections 11.5.8, 11.6.4, 11.7.3, or 11.7.4 and any nonaqueous liquid from Section 11.6.3 into the thimble and manually mix into the sand layer with a clean metal spatula, carefully breaking up any large lumps of sample.
- 12.3.6** Reassemble the pre-extracted SDS apparatus, and add a fresh charge of toluene to the receiver and reflux flask. Apply power to the heating mantle to begin refluxing. Adjust the reflux rate to match the rate of percolation through the sand and silica beds until water removal lessens the restriction to toluene flow. Frequently check the apparatus for foaming during the first 2 hours of extraction. If foaming occurs, reduce the reflux rate until foaming subsides.
- 12.3.7** Drain the water from the receiver at 1 to 2 hours and 8 to 9 hours, or sooner if the receiver fills with water. Reflux the sample for a total of 16 to 24 hours. Cool and disassemble the apparatus. Record the total volume of water collected.
- 12.3.8** Remove the distilling flask. Drain the water from the Dean-Stark receiver and add any toluene in the receiver to the extract in the flask.
- 12.3.9** Concentrate the extracts from particles (Sections 11.5-11.7) to approximately 10 mL using the rotary evaporator or heating mantle (Section 12.6.1 or 12.6.2), transfer to a 250-mL separatory funnel, and proceed with back-extraction (Section 12.5).
- 12.4** Extraction of tissue.
- 12.4.1** Add 30 to 40 g of powdered anhydrous sodium sulfate to each of the beakers (Section 11.8.1.4, 11.8.2.1, and 11.8.2.2) and mix thoroughly. Cover the beakers with aluminum foil and allow to equilibrate for 12-24 hours. Remix prior to extraction to prevent clumping.
- 12.4.2** Assemble and pre-extract the Soxhlet apparatus per Sections 12.3.1-12.3.4, except use the methylene chloride:n-hexane (1:1) mixture for the pre-extraction and rinsing and omit the quartz sand. The Dean-Stark moisture trap may also be omitted, if desired.
- 12.4.3** Reassemble the pre-extracted Soxhlet apparatus and add a fresh charge of methylene chloride:n-hexane to the reflux flask.
- 12.4.4** Transfer the sample/sodium sulfate mixture (Section 12.4.1) to the Soxhlet thimble, and install the thimble in the Soxhlet apparatus.
- 12.4.5** Rinse the beaker with several portions of solvent mixture and add to the thimble. Fill the thimble/receiver with solvent. Extract for 18 to 24 hours.
- 12.4.6** After extraction, cool and disassemble the apparatus.
- 12.4.7** Quantitatively transfer the extract to a macro-concentration device (Section 12.6), and concentrate to near dryness. Set aside the concentration apparatus for re-use.
- 12.4.8** Complete the removal of the solvent using the nitrogen blowdown procedure (Section 12.7) and a water bath temperature of 60°C. Weigh the receiver, record the weight, and return the receiver to the blowdown apparatus, concentrating the residue until a constant weight is obtained.
- 12.4.9** Percent lipid determination—The lipid content is determined by extraction of tissue with the same solvent system (methylene chloride:n-hexane) that was used in EPA's National Dioxin Study (Reference 15) so that lipid contents are consistent with that study.

Method 1668

- 12.4.9.1 Redissolve the residue in the receiver in n-hexane and spike 1.0 mL of the cleanup standard (Section 7.11) into the solution.
- 12.4.9.2 Transfer the residue/n-hexane to the anthropogenic isolation column (Section 13.6.1), retaining the boiling chips in the concentration apparatus. Use several rinses to assure that all material is transferred. If necessary, sonicate or heat the receiver slightly to assure that all material is re-dissolved. Allow the receiver to dry. Weigh the receiver and boiling chips.
- 12.4.9.3 Calculate the lipid content to the nearest three significant figures as follows:

$$\text{Percent lipid content} = \frac{\text{Weight of residue (g)}}{\text{Weight of tissue (g)}} \times 100$$

- 12.4.9.4 It is not necessary to determine the lipid content of the blank, IPR, or OPR aliquots.

12.5 Back-extraction with base and acid.

- 12.5.1 Spike 1.0 mL of the cleanup standard (Section 7.11) into the separatory funnels containing the sample and QC extracts from Section 12.2.3.4 or 12.3.9.
 - 12.5.2 Partition the extract against 50 mL of potassium hydroxide solution (Section 7.1.1). Shake for 2 minutes with periodic venting into a hood. Remove and discard the aqueous layer. Repeat the base washing until no color is visible in the aqueous layer to a maximum of four washings. Minimize contact time between the extract and the base to prevent degradation of the PCBs. Stronger potassium hydroxide solutions may be employed for back-extraction, provided that the laboratory meets the specifications for labeled compound recovery and demonstrates acceptable performance using the procedure in Section 9.2.
 - 12.5.3 Partition the extract against 50 mL of sodium chloride solution (Section 7.1.4) in the same way as with base. Discard the aqueous layer.
 - 12.5.4 Partition the extract against 50 mL of sulfuric acid (Section 7.1.2) in the same way as with base. Repeat the acid washing until no color is visible in the aqueous layer to a maximum of four washings.
 - 12.5.5 Repeat the partitioning against sodium chloride solution and discard the aqueous layer.
 - 12.5.6 Pour each extract through a drying column containing 7 to 10 cm of granular anhydrous sodium sulfate (Section 7.2.1). Rinse the separatory funnel with 30 to 50 mL of solvent, and pour through the drying column. Collect each extract in a round-bottom flask. Re-concentrate the sample and QC aliquots per Sections 12.6-12.7, and clean up the samples and QC aliquots per Section 13.
- 12.6 Macro-concentration—Extracts in toluene are concentrated using a rotary evaporator or a heating mantle; extracts in methylene chloride or n-hexane are concentrated using a rotary evaporator, heating mantle, or Kuderna-Danish apparatus.
- 12.6.1 Rotary evaporation—Concentrate the extracts in separate round-bottom flasks.
 - 12.6.1.1 Assemble the rotary evaporator according to manufacturer's instructions, and warm the water bath to 45°C. On a daily basis, pre-clean the rotary evaporator by concentrating

100 mL of clean extraction solvent through the system. Archive both the concentrated solvent and the solvent in the catch flask for a contamination check if necessary. Between samples, three 2- to 3-mL aliquots of solvent should be rinsed down the feed tube into a waste beaker.

- 12.6.1.2** Attach the round-bottom flask containing the sample extract to the rotary evaporator. Slowly apply vacuum to the system, and begin rotating the sample flask.
- 12.6.1.3** Lower the flask into the water bath, and adjust the speed of rotation and the temperature as required to complete concentration in 15 to 20 minutes. At the proper rate of concentration, the flow of solvent into the receiving flask will be steady, but no bumping or visible boiling of the extract will occur.

Note: *If the rate of concentration is too fast, analyte loss may occur.*

- 12.6.1.4** When the liquid in the concentration flask has reached an apparent volume of approximately 2 mL, remove the flask from the water bath and stop the rotation. Slowly and carefully admit air into the system. Be sure not to open the valve so quickly that the sample is blown out of the flask. Rinse the feed tube with approximately 2 mL of solvent.
- 12.6.1.5** Proceed to Section 12.6.4 for preparation for back-extraction or micro-concentration and solvent exchange.
- 12.6.2** Heating mantle—Concentrate the extracts in separate round-bottom flasks.
- 12.6.2.1** Add one or two clean boiling chips to the round-bottom flask, and attach a three-ball macro-Snyder column. Pre-wet the column by adding approximately 1 mL of solvent through the top. Place the round-bottom flask in a heating mantle, and apply heat as required to complete the concentration in 15 to 20 minutes. At the proper rate of distillation, the balls of the column will actively chatter, but the chambers will not flood.
- 12.6.2.2** When the liquid has reached an apparent volume of approximately 10 mL, remove the round-bottom flask from the heating mantle and allow the solvent to drain and cool for at least 10 minutes. Remove the Snyder column and rinse the glass joint into the receiver with small portions of solvent.
- 12.6.2.3** Proceed to Section 12.6.4 for preparation for back-extraction or micro-concentration and solvent exchange.
- 12.6.3** Kuderna-Danish (K-D)—Concentrate the extracts in separate 500-mL K-D flasks equipped with 10-mL concentrator tubes. The K-D technique is used for solvents such as methylene chloride and n-hexane. Toluene is difficult to concentrate using the K-D technique unless a water bath fed by a steam generator is used.
- 12.6.3.1** Add 1 to 2 clean boiling chips to the receiver. Attach a three-ball macro-Snyder column. Pre-wet the column by adding approximately 1 mL of solvent through the top. Place the K-D apparatus in a hot water bath so that the entire lower rounded surface of the flask is bathed with steam.

Method 1668

- 12.6.3.2 Adjust the vertical position of the apparatus and the water temperature as required to complete the concentration in 15 to 20 minutes. At the proper rate of distillation, the balls of the column will actively chatter but the chambers will not flood.
- 12.6.3.3 When the liquid has reached an apparent volume of 1 mL, remove the K-D apparatus from the bath and allow the solvent to drain and cool for at least 10 minutes. Remove the Snyder column and rinse the flask and its lower joint into the concentrator tube with 1 to 2 mL of solvent. A 5-mL syringe is recommended for this operation.
- 12.6.3.4 Remove the three-ball Snyder column, add a fresh boiling chip, and attach a two-ball micro-Snyder column to the concentrator tube. Pre-wet the column by adding approximately 0.5 mL of solvent through the top. Place the apparatus in the hot water bath.
- 12.6.3.5 Adjust the vertical position and the water temperature as required to complete the concentration in 5 to 10 minutes. At the proper rate of distillation, the balls of the column will actively chatter but the chambers will not flood.
- 12.6.3.6 When the liquid reaches an apparent volume of 0.5 mL, remove the apparatus from the water bath and allow to drain and cool for at least 10 minutes.
- 12.6.3.7 Proceed to 12.6.4 for preparation for back-extraction or micro-concentration and solvent exchange.
- 12.6.4 Preparation for back-extraction or micro-concentration and solvent exchange.
 - 12.6.4.1 For back-extraction (Section 12.5), transfer the extract to a 250-mL separatory funnel. Rinse the concentration vessel with small portions of n-hexane, adjust the n-hexane volume in the separatory funnel to 10 to 20 mL, and proceed to back-extraction (Section 12.5).
 - 12.6.4.2 For determination of the weight of residue in the extract or for clean-up procedures other than back-extraction, transfer the extract to a blowdown vial using 2-3 rinses of solvent. Proceed with micro-concentration and solvent exchange (Section 12.7).
- 12.7 Micro-concentration and solvent exchange.
 - 12.7.1 Extracts to be subjected to GPC or HPLC cleanup are exchanged into methylene chloride. Extracts to be cleaned up using silica gel, carbon, and/or Florisil are exchanged into n-hexane.
 - 12.7.2 Transfer the vial containing the sample extract to a nitrogen blowdown device. Adjust the flow of nitrogen so that the surface of the solvent is just visibly disturbed.

Note: *A large vortex in the solvent may cause analyte loss.*

- 12.7.3 Lower the vial into a 45°C water bath and continue concentrating.
 - 12.7.3.1 If the extract is to be concentrated to dryness for weight determination (Sections 12.4.8 and 13.6.4), blow dry until a constant weight is obtained.
 - 12.7.3.2 If the extract is to be concentrated for injection into the GC/MS or the solvent is to be exchanged for extract cleanup, proceed as follows:

- 12.7.4 When the volume of the liquid is approximately 100 μ L, add 2 to 3 mL of the desired solvent (methylene chloride for GPC and HPLC, or n-hexane for the other cleanups) and continue concentration to approximately 100 μ L. Repeat the addition of solvent and concentrate once more.
- 12.7.5 If the extract is to be cleaned up by GPC, adjust the volume of the extract to 5.0 mL with methylene chloride. If the extract is to be cleaned up by HPLC, further concentrate the extract to 30 μ L. Proceed with GPC or HPLC cleanup (Section 13.2 or 13.5, respectively).
- 12.7.6 If the extract is to be cleaned up by column chromatography (silica gel, Carbopak/Celite, or Florisil), bring the final volume to 1.0 mL with n-hexane. Proceed with column cleanups (Sections 13.3 - 13.4 and 13.7).
- 12.7.7 If the extract is to be concentrated for injection into the GC/MS (Section 14), quantitatively transfer the extract to a 0.3-mL conical vial for final concentration, rinsing the larger vial with n-hexane and adding the rinse to the conical vial. Reduce the volume to approximately 100 μ L. Add 10 μ L of nonane to the vial, and evaporate the solvent to the level of the nonane. Seal the vial and label with the sample number. Store in the dark at room temperature until ready for GC/MS analysis. If GC/MS analysis will not be performed on the same day, store the vial at $<-10^{\circ}\text{C}$.

13.0 Extract Cleanup

- 13.1 Cleanup may not be necessary for relatively clean samples (e.g., treated effluents, groundwater, drinking water). If particular circumstances require the use of a cleanup procedure, the analyst may use any or all of the procedures below or any other appropriate procedure. Before using a cleanup procedure, the analyst must demonstrate that the requirements of Section 9.2 can be met using the cleanup procedure. If PCBs 77, 126, and 169 only are to be determined, the cleanup procedures may be optimized for isolation of these compounds.
- 13.1.1 Gel permeation chromatography (Section 13.2) removes high molecular weight interferences that cause GC column performance to degrade. It should be used for all soil and sediment extracts. It may be used for water extracts that are expected to contain high molecular weight organic compounds (e.g., polymeric materials, humic acids). It may also be used for tissue extracts after initial cleanup on the anthropogenic isolation column (Section 13.6).
- 13.1.2 Acid, neutral, and basic silica gel (Section 13.3) and Florisil (Section 13.7) are used to remove nonpolar and polar interferences.
- 13.1.3 Carbopak/Celite (Section 13.4) can be used to separate PCBs 77, 126, and 169 from the mono- and di- ortho-substituted PCBs, if desired.
- 13.1.4 HPLC (Section 13.5) is used to provide specificity for certain congeners and congener groups.
- 13.1.5 The anthropogenic isolation column (Section 13.6) is used for removal of lipids from tissue samples.
- 13.2 Gel permeation chromatography (GPC).
- 13.2.1 Column packing.
- 13.2.1.1 Place 70 to 75 g of SX-3 Bio-beads (Section 6.7.1.1) in a 400- to 500-mL beaker.

Method 1668

- 13.2.1.2 Cover the beads with methylene chloride and allow to swell overnight (a minimum of 12 hours).
 - 13.2.1.3 Transfer the swelled beads to the column (Section 6.7.1.1) and pump solvent through the column, from bottom to top, at 4.5 to 5.5 mL/minute prior to connecting the column to the detector.
 - 13.2.1.4 After purging the column with solvent for 1 to 2 hours, adjust the column head pressure to 7 to 10 psig and purge for 4 to 5 hours to remove air. Maintain a head pressure of 7 to 10 psig. Connect the column to the detector (Section 6.7.1.4).
- 13.2.2 Column calibration.
- 13.2.2.1 Load 5 mL of the calibration solution (Section 7.4) into the sample loop.
 - 13.2.2.2 Inject the calibration solution and record the signal from the detector. The elution pattern will be corn oil, PCB 209, pentachlorophenol, perylene, and sulfur.
 - 13.2.2.3 Set the "dump time" to allow >85% removal of the corn oil and >85% collection of PCB 209.
 - 13.2.2.4 Set the "collect time" to the peak minimum between perylene and sulfur.
 - 13.2.2.5 Verify the calibration with the calibration solution after every 20 extracts. Calibration is verified if the recovery of the pentachlorophenol is greater than 85%. If calibration is not verified, the system shall be recalibrated using the calibration solution, and the previous 20 samples shall be re-extracted and cleaned up using the calibrated GPC system.
- 13.2.3 Extract cleanup—GPC requires that the column not be overloaded. The column specified in this method is designed to handle a maximum of 0.5 g of high molecular weight material in a 5-mL extract. If the extract is known or expected to contain more than 0.5 g, the extract is split into aliquots for GPC, and the aliquots are combined after elution from the column. The residue content of the extract may be obtained gravimetrically by evaporating the solvent from a 50- μ L aliquot.
- 13.2.3.1 Filter the extract or load through the filter holder (Section 6.7.1.3) to remove the particles. Load the 5.0-mL extract onto the column.
 - 13.2.3.2 Elute the extract using the calibration data determined in Section 13.2.2. Collect the eluate in a clean 400- to 500-mL beaker.
 - 13.2.3.3 Rinse the sample loading tube thoroughly with methylene chloride between extracts to prepare for the next sample.
 - 13.2.3.4 If a particularly dirty extract is encountered, a 5.0-mL methylene chloride blank shall be run through the system to check for carry-over.
 - 13.2.3.5 Concentrate the eluate per Section 12.6 and Section 12.7 for further cleanup or injection into the GC/MS.
- 13.3 Silica gel cleanup.
- 13.3.1 Place a glass-wool plug in a 15-mm ID chromatography column (Section 6.7.4.2). Pack the column bottom to top with 1 g silica gel (Section 7.5.1.1), 4 g basic silica gel (Section 7.5.1.3), 1 g silica gel, 8 g acid silica gel (Section 7.5.1.2), 2 g silica gel, and 4 g granular anhydrous sodium sulfate (Section 7.2.1). Tap the column to settle the adsorbents.

-
- 13.3.2 Pre-elute the column with 50 to 100 mL of n-hexane. Close the stopcock when the n-hexane is within 1 mm of the sodium sulfate. Discard the eluate. Check the column for channeling. If channeling is present, discard the column and prepare another.
- 13.3.3 Apply the concentrated extract to the column. Open the stopcock until the extract is within 1 mm of the sodium sulfate.
- 13.3.4 Rinse the receiver twice with 1-mL portions of n-hexane, and apply separately to the column. Elute the PCBs with 25 mL of n-hexane and collect the eluate.
- 13.3.5 Concentrate the eluate per Section 12.6 and 12.7 for further cleanup or injection into the HPLC or GC/MS.
- 13.3.6 For extracts of samples known to contain large quantities of other organic compounds (such as paper mill effluents), it may be advisable to increase the capacity of the silica gel column. This may be accomplished by increasing the strengths of the acid and basic silica gels. The acid silica gel (Section 7.5.1.2) may be increased in strength to as much as 44% w/w (7.9 g sulfuric acid added to 10 g silica gel). The basic silica gel (Section 7.5.1.3) may be increased in strength to as much as 33% w/w (50 mL 1N NaOH added to 100 g silica gel), or the potassium silicate (Section 7.5.1.4) may be used.
-

Note: *The use of stronger acid silica gel (44% w/w) may lead to charring of organic compounds in some extracts. The charred material may retain some of the analytes and lead to lower recoveries of the PCBs. Increasing the strengths of the acid and basic silica gel may also require different volumes of n-hexane than those specified above to elute the analytes from the column. Therefore, the performance of the method after such modifications must be verified by the procedure in Section 9.2.*

13.4 Carbon column (Reference 16).

- 13.4.1 Cut both ends from a 50-mL disposable serological pipet (Section 6.7.3.2) to produce a 20-cm column. Fire-polish both ends and flare both ends if desired. Insert a glass-wool plug at one end, and pack the column with 3.6 g of Carbopak/Celite (Section 7.5.2.3) to form an adsorbent bed 20 cm long. Insert a glass-wool plug on top of the bed to hold the adsorbent in place.
- 13.4.2 Pre-elute the column with 20 mL each in succession of toluene, methylene chloride, and n-hexane.
- 13.4.3 When the solvent is within 1 mm of the column packing, apply the n-hexane sample extract to the column. Rinse the sample container twice with 1-mL portions of n-hexane and apply separately to the column. Apply 2 mL of n-hexane to complete the transfer.
- 13.4.4 Elute the column with 25 mL of n-hexane and collect the eluate. This fraction will contain the mono- and di-ortho PCBs. If carbon particles are present in the eluate, filter through glass-fiber filter paper.
- 13.4.5 Elute the column with 15 mL of methanol and discard the eluate. The fraction discarded will contain residual lipids and other potential interferents, if present.

Method 1668

- 13.4.6 Elute the column with 15 mL of toluene and collect the eluate. This fraction will contain PCBs 77, 126, and 169. If carbon particles are present in the eluate, filter through glass-fiber filter paper.
- 13.4.7 Concentrate the fractions per Section 12.6 and 12.7 for further cleanup or injection into the HPLC or GC/MS.
- 13.5 HPLC (Reference 17).
- 13.5.1 Column calibration.
- 13.5.1.1 Prepare a calibration standard containing the toxic congeners and other congeners of interest at a concentration of approximately TBD pg/ μ L in methylene chloride.
- 13.5.1.2 Inject 30 μ L of the calibration solution into the HPLC and record the signal from the detector. Collect the eluant for reuse. The elution order will be the mono- through deca- congeners.
- 13.5.1.3 Establish the collection time for the congeners of interest. Following calibration, flush the injection system with copious quantities of methylene chloride, including a minimum of five 50- μ L injections while the detector is monitored, to ensure that residual PCBs are removed from the system.
- 13.5.1.4 Verify the calibration with the calibration solution after every 20 extracts. Calibration is verified if the recovery of the PCBs from the calibration standard is 75 to 125% compared to the calibration (Section 13.5.1.1). If calibration is not verified, the system shall be recalibrated using the calibration solution, and the previous 20 samples shall be re-extracted and cleaned up using the calibrated system.
- 13.5.2 Extract cleanup—HPLC requires that the column not be overloaded. The column specified in this method is designed to handle a maximum of 30 μ L of extract. If the extract cannot be concentrated to less than 30 μ L, it is split into fractions and the fractions are combined after elution from the column.
- 13.5.2.1 Rinse the sides of the vial twice with 30 μ L of methylene chloride and reduce to 30 μ L with the evaporation apparatus (Section 6.8.3).
- 13.5.2.2 Inject the 30 μ L extract into the HPLC.
- 13.5.2.3 Elute the extract using the calibration data determined in Section 13.5.1. Collect the fraction(s) in a clean 20-mL concentrator tube containing 5 mL of n-hexane:acetone (1:1 v/v).
- 13.5.2.4 If an extract containing greater than TBD ng/mL of total PCBs is encountered, a 30- μ L methylene chloride blank shall be run through the system to check for carry-over.
- 13.5.2.5 Concentrate the eluate per Section 12.7 for injection into the GC/MS.
- 13.6 Anthropogenic isolation column (References 1-2)—Used for removal of lipids from tissue extracts.
- 13.6.1 Prepare the column as given in Section 7.5.3.
- 13.6.2 Pre-elute the column with 100 mL of n-hexane. Drain the n-hexane layer to the top of the column, but do not expose the sodium sulfate.

- 13.6.3** Load the sample and rinses (Section 12.4.9.2) onto the column by draining each portion to the top of the bed. Elute the PCBs from the column into the apparatus used for concentration (Section 12.4.7) using 200 mL of n-hexane.
- 13.6.4** Concentrate the cleaned up extract (Sections 12.6-12.7) to constant weight per Section 12.7.3.1. If more than 500 mg of material remains, repeat the cleanup using a fresh anthropogenic isolation column.
- 13.6.5** Redissolve the extract in a solvent suitable for the additional cleanups to be used (Section 13.2-13.5 and 13.7).
- 13.6.6** Spike 1.0 mL of the cleanup standard (Section 7.11) into the residue/solvent.
- 13.6.7** Clean up the extract using the procedures in Sections 13.2-13.5 and 13.7. Florisil (Section 13.7) and carbon (Section 13.4) are recommended as minimum additional cleanup steps.
- 13.6.8** Following cleanup, concentrate the extract to 10 μ L as described in Section 12.7 and proceed with the analysis in Section 14.
- 13.7** Florisil cleanup (Reference 18).
- 13.7.1** Begin to drain the n-hexane from the column (Section 7.5.4). Adjust the flow rate of eluant to 4.5-5.0 mL/min.
- 13.7.2** When the n-hexane is within 1 mm of the sodium sulfate, apply the sample extract (in n-hexane) to the column. Rinse the sample container twice with 1-mL portions of n-hexane and apply to the column.
- 13.7.3** Elute the mono-ortho and di-ortho PCBs with approximately 165 mL of n-hexane and collect the eluate. Elute the non-ortho co-planar PCBs with approximately 100 mL of 6% ether:n-hexane and collect the eluate. The exact volumes of solvents will need to be determined for each batch of Florisil. If the mono/di-ortho PCBs are not to be separated from the non-ortho co-planar PCBs, elute all PCBs with 6% ether:n-hexane.
- 13.7.4** Concentrate the eluate(s) per Sections 12.6-12.7 for further cleanup or for injection into the HPLC or GC/MS.

14.0 HRGC/HRMS Analysis

- 14.1** Establish the operating conditions given in Section 10.1.
- 14.2** Add 10 μ L of the appropriate internal standard solution (Section 7.12) to the sample extract immediately prior to injection to minimize the possibility of loss by evaporation, adsorption, or reaction. If an extract is to be reanalyzed and evaporation has occurred, do not add more instrument internal standard solution. Rather, bring the extract back to its previous volume (e.g., 19 μ L) with pure nonane only (18 μ L if 2 μ L injections are used).
- 14.3** Inject 1.0 or 2.0 μ L of the concentrated extract containing the internal standard solution, using on-column or splitless injection. The volume injected must be identical to the volume used for calibration (Section 10). Start the GC column initial isothermal hold upon injection. Start MS data collection after the solvent peak elutes. Stop data collection after the $^{13}\text{C}_{12}$ -PCB 209 has eluted. If PCBs 77, 126, and 169 only are to be determined, stop data collection after $^{13}\text{C}_{12}$ -PCB 169 has eluted. Return the column to the initial temperature for analysis of the next extract or standard.

15.0 System and Laboratory Performance

- 15.1 At the beginning of each 12-hour shift during which analyses are performed, GC/MS system performance and calibration are verified for all native PCBs and labeled compounds. For these tests, analysis of the CS3 calibration verification (VER) standard (Section 7.13 and Table 4) and the congener specificity test standards (Section 7.15 and Table 5) shall be used to verify all performance criteria. Adjustment and/or recalibration (Section 10) shall be performed until all performance criteria are met. Only after all performance criteria are met may samples, blanks, IPRs, and OPRs be analyzed.
- 15.2 MS resolution—A static resolving power of at least 10,000 (10% valley definition) must be demonstrated at the appropriate m/z before any analysis is performed. Static resolving power checks must be performed at the beginning and at the end of each 12-hour shift according to procedures in Section 10.1.2. Corrective actions must be implemented whenever the resolving power does not meet the requirement.
- 15.3 Calibration verification.
- 15.3.1 Inject the VER standard using the procedure in Section 14.
- 15.3.2 The m/z abundance ratios for all PCBs shall be within the limits in Table 9; otherwise, the mass spectrometer shall be adjusted until the m/z abundance ratios fall within the limits specified, and the verification test shall be repeated. If the adjustment alters the resolution of the mass spectrometer, resolution shall be verified (Section 10.1.2) prior to repeat of the verification test.
- 15.3.3 The peaks representing each native PCB and labeled compound in the VER standard must be present with a S/N of at least 10; otherwise, the mass spectrometer shall be adjusted and the verification test repeated.
- 15.3.4 Compute the concentration of each native PCB compound by isotope dilution (Section 17.1) for those compounds that have labeled analogs (Table 1). Compute the concentration of each native compound that does not have a labeled analog and of each labeled compound by the internal standard method (Section 17.2). These concentrations are computed based on the calibration data in Section 10.
- 15.3.5 For each compound, compare the concentration with the calibration verification limit in Table 6. If PCBs 77, 126, and 169 only are to be determined, compare the concentration to the limit in Table 6a. If all compounds meet the acceptance criteria, calibration has been verified and analysis of standards and sample extracts may proceed. If, however, any compound fails its respective limit, the measurement system is not performing properly for that compound. In this event, prepare a fresh calibration standard or correct the problem causing the failure and repeat the resolution (Section 15.2) and verification (Section 15.3) tests, or recalibrate (Section 10).
- 15.4 Retention times and GC resolution.
- 15.4.1 Retention times.
- 15.4.1.1 Absolute—The absolute retention times of the GC/MS internal standards in the verification test (Section 15.3) shall be within ± 15 seconds of the retention times obtained during calibration (Section 10.2.4).

- 15.4.1.2** Relative—The relative retention times of native PCBs and labeled compounds in the verification test (Section 15.3) shall be within 5 percent of the relative retention times given in Table 2.
- 15.4.2** GC resolution.
- 15.4.2.1** Inject the isomer specificity standards (Section 7.15) on their respective columns.
- 15.4.2.2** The valley height between PCBs 123 and 118 at m/z 325.8804 shall not exceed 10 percent on the SPB-Octyl column, and the valley height between PCBs 156 and 157 shall not exceed 10 percent at m/z 359.8415 on the DB-1 column (Figures 6 and 7).
- 15.4.3** If the absolute retention time of any compound is not within the limits specified or if the congeners are not resolved, the GC is not performing properly. In this event, adjust the GC and repeat the verification test (Section 15.3) or recalibrate (Section 10), or replace the GC column and either verify calibration or recalibrate.
- 15.5** Ongoing precision and recovery.
- 15.5.1** Analyze the extract of the ongoing precision and recovery (OPR) aliquot (Section 11.4.2.5, 11.5.4, 11.6.2, 11.7.4, or 11.8.3.2) prior to analysis of samples from the same batch.
- 15.5.2** Compute the concentration of each native PCB by isotope dilution for those compounds that have labeled analogs (Section 17.1). Compute the concentration of the native PCBs that have no labeled analog and each labeled compound by the internal standard method (Section 17.2).
- 15.5.3** For each PCB and labeled compound, compare the concentration to the OPR limits given in Table 6. If PCBs 77, 126, and 169 only are to be determined, compare the concentration to the limits in Table 6a. If all compounds meet the acceptance criteria, system performance is acceptable and analysis of blanks and samples may proceed. If, however, any individual concentration falls outside of the range given, the extraction/concentration processes are not being performed properly for that compound. In this event, correct the problem, re-prepare, extract, and clean up the sample batch and repeat the ongoing precision and recovery test (Section 15.5).
- 15.5.4** Add results that pass the specifications in Section 15.5.3 to initial and previous ongoing data for each compound in each matrix. Update QC charts to form a graphic representation of continued laboratory performance. Develop a statement of laboratory accuracy for each congener in each matrix type by calculating the average percent recovery (R) and the standard deviation of percent recovery (S_R). Express the accuracy as a recovery interval from $R - 2S_R$ to $R + 2S_R$. For example, if $R = 95\%$ and $S_R = 5\%$, the accuracy is 85 to 105%.
- 15.6** Blank—Analyze the method blank extracted with each sample batch immediately following analysis of the OPR aliquot to demonstrate freedom from contamination and freedom from carryover from the OPR analysis. The results of the analysis of the blank must meet the specifications in Section 9.5.2 before sample analyses may proceed.

16.0 Qualitative Determination

A PCB or labeled compound is identified in a standard, blank, or sample when all of the criteria in Sections 16.1 through 16.4 are met.

- 16.1 The signals for the two exact m/z 's in Table 8 must be present and must maximize within the same two seconds.
- 16.2 The signal-to-noise ratio (S/N) for the GC peak at each exact m/z must be greater than or equal to 2.5 for each PCB detected in a sample extract, and greater than or equal to 10 for all PCBs in the calibration standard (Sections 10.2.3 and 15.3.3).
- 16.3 The ratio of the integrated areas of the two exact m/z 's specified in Table 8 must be within the limit in Table 9, or within ± 10 percent of the ratio in the midpoint (CS3) calibration or calibration verification (VER), whichever is most recent.
- 16.4 The relative retention time of the peak for a toxic PCB must be within 5 percent of the relative retention times listed in Table 2. The retention time of peaks representing PCBs other than the toxic PCBs must be within the retention time windows established in Section 10.3.
- 16.5 Confirmatory analysis—Isomer specificity for PCBs 156 and 157 cannot be achieved on the SPB-Octyl column. Therefore, any sample in which these PCBs are tentatively identified by analysis on the SPB-Octyl column and when rigorous identification is required must have a confirmatory analysis performed on a DB-1 or equivalent GC column. The operating conditions in Section 10.1.1 may be adjusted to optimize the analysis on the second GC column, but the GC/MS must meet the mass resolution and calibration specifications in Section 10.
- 16.6 If the criteria for identification in Sections 16.1-16.5 are not met, the PCB has not been identified and the results may not be reported for regulatory compliance purposes. If interferences preclude identification, a new aliquot of sample must be extracted, further cleaned up, and analyzed.

17.0 Quantitative Determination

- 17.1 Isotope dilution quantitation—By adding a known amount of a labeled compound to every sample prior to extraction, correction for recovery of the PCB can be made because the native compound and its labeled analog exhibit similar effects upon extraction, concentration, and gas chromatography. Relative response (RR) values are used in conjunction with the initial calibration data described in Section 10.5 to determine concentrations directly, so long as labeled compound spiking levels are constant, using the following equation:

$$C_{ex} \text{ (ng/mL)} = \frac{(A1_n + A2_n) C_l}{(A1_l + A2_l) RR}$$

where:

C_{ex} = The concentration of the PCB in the extract.

The other terms are as defined in Section 10.5.2

Any peaks representing the other congeners are quantitated using an average of the response factors from all of the labeled PCBs isomers at the same level of chlorination.

17.2 Internal standard quantitation and labeled compound recovery.

- 17.2.1** Compute the concentrations of labeled analogs (including the cleanup standard) in the extract using the response factors determined from the initial calibration data (Section 10.6) and the following equation:

$$C_{ex} \text{ (ng/mL)} = \frac{(A1_s + A2_s) C_{is}}{(A1_{is} + A2_{is}) RF}$$

where:

C_{ex} = The concentration of the labeled compound in the extract.

The other terms are as defined in Section 10.6.1

- 17.2.2** Using the concentration in the extract determined above, compute the percent recovery of the labeled compounds (including the cleanup standard) using the following equation:

$$\text{Recovery (\%)} = \frac{\text{Concentration found } (\mu\text{g/mL})}{\text{Concentration spiked } (\mu\text{g/mL})} \times 100$$

- 17.3** The concentration of a native PCB in the solid phase of the sample is computed using the concentration of the compound in the extract and the weight of the solids (Section 11.2.2.3), as follows:

$$\text{Concentration in solid (ng/kg)} = \frac{(C_{ex} \times V_{ex})}{W_s}$$

where:

C_{ex} = The concentration of the compound in the extract.

V_{ex} = The extract volume in mL.

W_s = The sample weight (dry weight) in kg.

- 17.4** The concentration of a native PCB in the aqueous phase of the sample is computed using the concentration of the compound in the extract and the volume of water extracted (Section 11.4), as follows:

$$\text{Concentration in aqueous phase (pg/L)} = \frac{(C_{ex} \times V_{ex})}{V_s}$$

where:

C_{ex} = The concentration of the compound in the extract.

V_{ex} = The extract volume in mL.

V_s = The sample volume in liters.

Method 1668

- 17.5** If the SICP area at either quantitation m/z for any compound exceeds the calibration range of the system, a smaller sample aliquot is extracted.
- 17.5.1** For aqueous samples containing 1% solids or less, dilute 100 mL, 10 mL, etc., of sample to 1 L with reagent water and re-prepare, extract, clean up, and analyze per Sections 11 - 14.
- 17.5.2** For samples containing greater than 1% solids, extract an amount of sample equal to 1/10, 1/100, etc., of the amount used in Section 11.5.1. Re-prepare, extract, clean up, and analyze per Sections 11-14.
- 17.5.3** If a smaller sample size will not be representative of the entire sample, dilute the sample extract by a factor of 10, adjust the concentration of the instrument internal standard to 100 pg/ μ L in the extract, and analyze an aliquot of this diluted extract by the internal standard method.
- 17.6** Results are reported to three significant figures for the PCBs and labeled compounds found in all standards, blanks, and samples.
- 17.6.1** Reporting units and levels.
- 17.6.1.1** Aqueous samples—Report results in pg/L (parts-per-quadrillion).
- 17.6.1.2** Samples containing greater than 1% solids (soils, sediments, filter cake, compost)—Report results in ng/kg based on the dry weight of the sample. Report the percent solids so that the result may be corrected.
- 17.6.1.3** Tissues—Report results in ng/kg of wet tissue, not on the basis of the lipid content of the sample. Report the percent lipid content, so that the data user can calculate the concentration on a lipid basis if desired.
- 17.6.1.4** Reporting level.
- 17.6.1.4.1** Standards (VER, IPR, OPR) and samples—Report results at or above the minimum level (Table 2). Report results below the minimum level as not detected or as required by the regulatory authority.
- 17.6.1.4.2** Blanks—Report results above the MDL or as required by the regulatory authority. Do not blank-correct results. If a blank accompanying a sample result shows contamination above the MDL for the congener, flag the sample result and report the results for the sample and the accompanying blank.
- 17.6.2** Results for PCBs in samples that have been diluted are reported at the least dilute level at which the areas at the quantitation m/z 's are within the calibration range (Section 17.5).
- 17.6.3** For PCBs having a labeled analog, results are reported at the least dilute level at which the area at the quantitation m/z is within the calibration range (Section 17.5) and the labeled compound recovery is within the normal range for the method (Section 9.3 and Tables 6, 6a, 7, and 7a).
- 17.6.4** Additionally, if requested, the total concentration of all congeners at a given level of chlorination (i.e., total TCB, total PeCB, total HxCB, etc.) may be reported by summing the concentrations of all congeners identified in that level of chlorination, including both the toxic and other congeners.

18.0 Analysis of Complex Samples

- 18.1 Some samples may contain high levels (>10 ng/L; >1000 ng/kg) of the compounds of interest, interfering compounds, and/or polymeric materials. Some extracts will not concentrate to 10 μ L (Section 12.7); others may overload the GC column and/or mass spectrometer.
- 18.2 Analyze a smaller aliquot of the sample (Section 17.5) when the extract will not concentrate to 10 μ L after all cleanup procedures have been exhausted.
- 18.3 Several laboratories have reported that elimination of several of the toxic PCBs, particularly non-coplanar congeners 105, 114, 118, 123, 156, 157, and 167 is difficult. Backgrounds of these congeners can therefore interfere with the determination of these congeners in environmental samples. Care should therefore be exercised in the determination of these congeners.
- 18.4 Recovery of labeled compounds—In most samples, recoveries of the labeled compounds will be similar to those from reagent water or from the alternate matrix (Section 7.6).
 - 18.4.1 If the recovery of any of the labeled compounds is outside of the normal range (Table 7), a diluted sample shall be analyzed (Section 17.5).
 - 18.4.2 If the recovery of any of the labeled compounds in the diluted sample is outside of normal range, the calibration verification standard (Section 7.13) shall be analyzed and calibration verified (Section 15.3).
 - 18.4.3 If the calibration cannot be verified, a new calibration must be performed and the original sample extract reanalyzed.
 - 18.4.4 If the calibration is verified and the diluted sample does not meet the limits for labeled compound recovery, the method does not apply to the sample being analyzed and the result may not be reported for regulatory compliance purposes. In this case, alternate extraction and cleanup procedures in this method must be employed to resolve the interference. If all cleanup procedures in this method have been employed and labeled compound recovery remains outside of the normal range, extraction and/or cleanup procedures that are beyond this scope of this method will be required to analyze these samples.

19.0 Method Performance

For this draft version of Method 1668, performance was validated and preliminary data were collected in a single laboratory.

20.0 Pollution Prevention

- 20.1 The solvents used in this method pose little threat to the environment when managed properly. The solvent evaporation techniques used in this method are amenable to solvent recovery, and it is recommended that the laboratory recover solvents wherever feasible.
- 20.2 Standards should be prepared in volumes consistent with laboratory use to minimize disposal of standards.

Method 1668

21.0 Waste Management

- 21.1 It is the laboratory's responsibility to comply with all federal, state, and local regulations governing waste management, particularly the hazardous waste identification rules and land disposal restrictions, and to protect the air, water, and land by minimizing and controlling all releases from fume hoods and bench operations. Compliance is also required with any sewage discharge permits and regulations.
- 21.2 Samples containing HCl or H₂SO₄ to pH <2 are hazardous and must be neutralized before being poured down a drain or must be handled as hazardous waste.
- 21.3 The PCBs decompose above 800°C. Low-level waste such as absorbent paper, tissues, animal remains, and plastic gloves may be burned in an appropriate incinerator. Gross quantities (milligrams) should be packaged securely and disposed of through commercial or governmental channels that are capable of handling extremely toxic wastes.
- 21.4 [This section may need to be modified to accommodate the PCBs: Liquid or soluble waste should be dissolved in methanol or ethanol and irradiated with ultraviolet light with a wavelength shorter than 290 nm for several days. Use F40 BL or equivalent lamps. Analyze liquid wastes, and dispose of the solutions when the PCBs can no longer be detected.]
- 21.5 For further information on waste management, consult "The Waste Management Manual for Laboratory Personnel" and "Less is Better—Laboratory Chemical Management for Waste Reduction," available from the American Chemical Society's Department of Government Relations and Science Policy, 1155 16th Street N.W., Washington, D.C. 20036.

22.0 References

- 1 Kuehl, D.W., B.C. Butterworth, J. Libal, and P. Marquis, "An Isotope Dilution High Resolution Gas Chromatographic-High Resolution Mass Spectrometric Method for the Determination of Coplanar Polychlorinated Biphenyls: Application to Fish and Marine Mammals," *Chemosphere* 22:9-10, 849-858, 1991.
- 2 Feltz, Kevin P., Donald E. Tillitt, Robert W. Gale, Paul H. Peterman, *Environ. Sci. Tech.* TBD.
- 3 "Analysis of Coplanar PCBs," Axys Environmental Systems Ltd., Fax from Mary McFarland to Dale Rushneck dated November 25, 1994, available from the EPA Sample Control Center, operated by DynCorp I&ET, 300 N. Lee St, Alexandria, VA 22314.
- 4 Ahlborg, U.G., G.C. Becking, L.S. Birnbaum, A. Brouwer, H.J.G.M. Derks, M. Feeley, G. Golor, A. Hanberg, J.C. Larsen, A.K.D. Liem, S.H. Safe, C. Schlatter, F. Waern, M. Younes, and E. Yrjänheikki, "Toxic Equivalency Factors for Dioxin-like PCBs," *Chemosphere* 28:6, 1049-1067, 1994.
- 5 "Working with Carcinogens," Department of Health, Education, & Welfare, Public Health Service, Centers for Disease Control, NIOSH, Publication 77-206, August 1977, NTIS PB-277256.
- 6 "OSHA Safety and Health Standards, General Industry," OSHA 2206, 29 CFR 1910.
- 7 "Safety in Academic Chemistry Laboratories," ACS Committee on Chemical Safety, 1979.

- 8 "Standard Methods for the Examination of Water and Wastewater," 18th edition and later revisions, American Public Health Association, 1015 15th St, N.W., Washington, DC 20005, 1-35: Section 1090 (Safety), 1992.
- 9 "Method 613—2,3,7,8-Tetrachlorodibenzo-*p*-dioxin," 40 *CFR* 136 (49 *FR* 43234), October 26, 1984, Section 4.1.
- 10 Lamparski, L.L., and Nestruck, T.J., "Novel Extraction Device for the Determination of Chlorinated Dibenzo-*p*-dioxins (PCDDs) and Dibenzofurans (PCDFs) in Matrices Containing Water," *Chemosphere*, 19:27-31, 1989.
- 11 Provost, L.P., and Elder, R.S., "Interpretation of Percent Recovery Data," *American Laboratory*, 15: 56-83, 1983.
- 12 "Standard Practice for Sampling Water," ASTM Annual Book of Standards, ASTM, 1916 Race Street, Philadelphia, PA 19103-1187, 1980.
- 13 "Methods 330.4 and 330.5 for Total Residual Chlorine," USEPA, EMSL, Cincinnati, OH 45268, EPA 600/4-70-020, March 1979.
- 14 "Handbook of Analytical Quality Control in Water and Wastewater Laboratories," USEPA EMSL, Cincinnati, OH 45268, EPA-600/4-79-019, March 1979.
- 15 "Analytical Procedures and Quality Assurance Plan for the Determination of PCDD/PCDF in Fish", U.S. Environmental Protection Agency, Environmental Research Laboratory, Duluth MN 55804, EPA/600/3-90/022, March 1990.
- 16 Storr-Hansen, E. and T. Cederberg, "Determination of Coplanar Polychlorinated Biphenyl (CB) Congeners in Seal Tissues by Chromatography on Active Carbon, Dual-Column High Resolution GC/ECD and High Resolution GC/High Resolution MS" *Chemosphere* 24:9, 1181-1196, 1992.
- 17 Workman, S.M., TBD [or Peterman in Reference 2]
- 18 Tessari, J.D., Personal communication with Dale Rushneck, available from the EPA Sample Control Center, operated by DynCorp I&ET, 300 N. Lee St., Alexandria, VA 22314 (703-519-1140).

Method 1668

23.0 Tables and Figures

Table 1. Toxic Polychlorinated Biphenyls Determined by Isotope Dilution and Internal Standard High Resolution Gas Chromatography (HRGC)/High Resolution Mass Spectrometry (HRMS)

PCB ¹	Native compound CAS Registry No.	IUPAC No.	¹³ C ₁₂ analog CAS Registry No.
3,3',4,4'-TCB	32598-13-3	77	160901-67-7
2,3,3',4,4'-PeCB	32598-14-4	105	160901-70-2
2,3,4,4',5-PeCB	74472-37-0	114	160901-72-4
2,3',4,4',5-PeCB	31508-00-6	118	160901-73-5
2',3,4,4',5-PeCB	65510-44-3	123	160901-74-6
3,3',4,4',5-PeCB	57465-28-8	126	160901-75-7
2,3,3',4,4',5-HxCB	38380-08-4	156	160901-77-9
2,3,3',4,4',5'-HxCB	69782-90-7	157	160901-78-0
2,3',4,4',5,5'-HxCB	52663-72-6	167	161627-18-5
3,3',4,4',5,5'-HxCB	32774-16-6	169	160901-79-1
2,2',3,3',4,4',5-HpCB	35065-30-6	170	160901-80-4
2,2',3,4,4',5,5'-HpCB	35065-29-3	180	160901-82-6
2,3,3',4,4',5,5'-HpCB	39635-31-9	189	160901-83-7
Cleanup standards			
¹³ C ₁₂ -3,4,4',5-TCB		81	160901-68-8
¹³ C ₁₂ -2,3,3',5,5'-PeCB		111	160901-71-3
Internal standards			
¹³ C ₁₂ -2,2',5,5'-TCB		52	160901-66-6
¹³ C ₁₂ -2,2',4,4,5'-PeCB		101	160901-69-9
¹³ C ₁₂ -2,2',3,4,4',5'-HxCB		138	160901-76-8
¹³ C ₁₂ -2,2',3,3',5,5',6-HpCB		178	160901-81-5
Final eluter standard			
¹³ C ₁₂ -DCB		209	160901-84-8

¹ Polychlorinated biphenyls:

TCB	=	Tetrachlorobiphenyl
PeCB	=	Pentachlorobiphenyl
HxCB	=	Hexachlorobiphenyl
HpCB	=	Heptachlorobiphenyl
DCB	=	Decachlorobiphenyl

Table 2. Retention Time (RT) References, Quantitation References, Relative Retention Times (RRTs), Estimated Method Detection Limits (EMDLs), and Estimated Minimum Levels (EMLs) for the Toxic PCBs^a

IUPAC ¹ No.	Labeled or native PCB	IUPAC ¹ No.	Retention time and quantitation reference	RT (min) ²	RRT	Matrix and Concentration			
						Water (pg/l)	Other (ng/Kg)	Extract (pg/ul)	EML
52L	13C12-2,2',5,5'-TCB	52L	13C12-2,2',5,5'-TCB	12.87	1.000				
81L	13C12-3,4,4',5'-TCB ⁴	52L	13C12-2,2',5,5'-TCB	19.65	1.527				
77L	13C12-3,3',4,4'-TCB	52L	13C12-2,2',5,5'-TCB	20.15	1.566				
77	3,3',4,4'-TCB	77L	13C12-3,3',4,4'-TCB	20.18	1.002	5	20	0.5	2
Penta congeners using 13C12-2,2',4,4',5,5'-PeCB (#101L) as the injection internal standard									
101L	13C12-2,2',4,5,5'-PeCB	101L	13C12-2,2',4,5,5'-PeCB	17.83	1.000				
111L	13C12-2,3,3',5,5'-PeCB ⁴	101L	13C12-2,2',4,5,5'-PeCB	20.12	1.128				
123	2,3,4,4',5-PeCB	118L	13C12-2,3',4,4',5-PeCB	21.98	0.987	40	100	4	10
118L	13C12-2,3',4,4',5-PeCB	101L	13C12-2,2',4,5,5'-PeCB	22.27	1.249				
118	2,3',4,4',5-PeCB	118L	13C12-2,3',4,4',5-PeCB	22.30	1.001	60	200	6	20
114	2,3,4,4',5-PeCB	105L	13C12-2,3',4,4',5-PeCB	22.82	0.974	600	2000	60	200
105L	13C12-2,3,3',4,4',PeCB	101L	13C12-2,2',4,5,5'-PeCB	23.42	1.313				
105	2,3,3',4,4'-PeCB	105L	13C12-2,3,3',4,4'-PeCB	23.43	1.000	400	1000	40	100
126L	13C12-3,3',4,4',5-PeCB	101L	13C12-2,2',4,5,5'-PeCB	26.55	1.489				
126	3,3',4,4',5-PeCB	126L	13C12-3,3',4,4',5-PeCB	26.56	1.000	40	100	10	4
Hexa congeners using 13C12-2,2',3,4,4',5'-HxCB (#138L) as the injection internal standard									
138L	13C12-2,2',3,4,4',5'-HxCB	101L	13C12-2,2',4,5,5'-PeCB	25.35	1.422				
167L	13C12-2,3',4,4',5,5'-HxCB	138L	13C12-2,2',3,4,4',5'-HxCB	28.50	1.124				
167	2,3',4,4',5,5'-HxCB	167L	13C12-2,3',4,4',5,5'-HxCB	28.52	1.001	60	200	6	20
156L	13C12-2,3,3',4,4',5'-HxCB	138L	13C12-2,2',3,4,4',5'-HxCB	29.77	1.174				
157L	13C12-2,3,3',4,4',5'-HxCB	138L	13C12-2,2',3,4,4',5'-HxCB	29.77	1.174				
156	2,3,3',4,4',5'-HxCB	156L	13C12-2,3,3',4,4',5'-HxCB	29.80	1.001	60	200	6	20
157	2,3,3',4,4',5'-HxCB	157L	13C12-2,3,3',4,4',5'-HxCB	29.80	1.001	60	200	6	20
169L	13C12-3,3',4,4',5,5'-HxCB	138L	13C12-2,2',3,4,4',5'-HxCB	33.38	1.317				
169	3,3',4,4',5,5'-HxCB	169L	13C12-3,3',4,4',5,5'-HxCB	33.42	1.001	60	200	6	20

^aContinued on next page

Table 2. (cont.) Retention Time (RT) References, Quantitation References, Relative Retention Times (RRTs), Estimated Method Detection Limits (EMDLs), and Estimated Minimum Levels (EMLs) for the Toxic PCBs

IUPAC ¹ No.	Labeled or native PCB	IUPAC ¹ No.	Retention time and quantitation reference	RT (min) ²	RRT	Matrix and Concentration		
						Water (pg/l)	Other (ng/kg)	Extract (pg/l)
Hepta and deca congeners using 13C12-2,2',3,3',5,5',6-HpCB (#178L) as the injection internal standard								
178L	13C12-2,2',3,3',5,5',6-HpCB	101L	13C12-2,2',4,5,5',6-PeCB	25.78	1.446			
180L	13C12-2,2',3,4,4',5,5'-HpCB	178L	13C12-2,2',3,3',5,5',6-HpCB	31.30	1.214			
180	2,2',3,4,4',5,5'-HpCB	180L	13C12-2,2',3,4,4',5,5'-HpCB	31.32	1.001	60	200	6
170	2,2',3,3',4,4',5-HpCB	180L	13C12-2,2',3,4,4',5,5'-HpCB	32.75	1.046	60	200	6
189L	13C12-2,3,3',4,4',5,5'-HpCB	178L	13C12-2,2',3,3',5,5',6-HpCB	36.32	1.409			
189	2,3,3',4,4',5,5'-HpCB	189L	13C12-2,3,3',4,4',5,5'-HpCB	36.35	1.001	60	200	6
209L	13C12-DCB ⁵	178L	13C12-2,2',3,3',5,5',6-HpCB	43.48	1.687			20

¹ Suffix "L" indicates labeled compound
² Retention time data are for SPB-octyl column sorted in ascending retention time order within each congener group
³ Some EMDLs and EMLs have been set above the lowest calibration point (Table 4) because backgrounds of these particular congeners are difficult to eliminate from laboratory analytical systems
⁴ Cleanup standard
⁵ Final eluter

Table 3. Concentrations of Stock and Spiking Solutions Containing the Native PCBs and Labeled Compounds

PCB congener	IUPAC No.	Labeled compound		Precision and Recovery	
		Stock ¹ (ng/mL)	Spiking ² (ng/mL)	Stock ³ (ng/mL)	Spiking ⁴ (ng/mL)
3,3',4,4'-TCB	77	-	-	220	0.4
2,3,3',4,4'-PeCB	105	-	-	1000	20.0
2,3,4,4',5-PeCB	114	-	-	1000	20.0
2,3',4,4',5-PeCB	118	-	-	1000	20.0
2',3,4,4',5-PeCB	123	-	-	1000	20.0
3,3',4,4',5-PeCB	126	-	-	100	2.0
2,3,3',4,4',5-HxCB	156	-	-	1000	20.0
2,3,3',4,4',5'-HxCB	157	-	-	1000	20.0
2,3',4,4',5,5'-HxCB	167	-	-	1000	20.0
3,3',4,4',5,5'-HxCB	169	-	-	200	4.0
2,2',3,3',4,4',5-HpCB	170	-	-	200	4.0
2,2',3,4,4',5,5'-HpCB	180	-	-	1000	20.0
2,3,3',4,4',5,5'-HpCB	189	-	-	200	4.0
13C12-3,3',4,4'-TCB	77L	1000	2.0	-	-
13C12-2,3,3',4,4'-PeCB	105L	1000	2.0	-	-
13C12-2,3',4,4',5-PeCB	118L	1000	2.0	-	-
13C12-3,3',4,4',5-PeCB	126L	1000	2.0	-	-
13C12-2,3,3',4,4',5-HxCB	156L	1000	2.0	-	-
13C12-2,3,3',4,4',5'-HxCB	157L	1000	2.0	-	-
13C12-2,3',4,4',5,5'-HxCB	167L	1000	2.0	-	-
13C12-3,3',4,4',5,5'-HxCB	169L	1000	2.0	-	-
13C12-2,2',3,4,4',5,5'-HpCB	180L	1000	2.0	-	-
13C12-2,3,3',4,4',5,5'-HpCB	189L	1000	2.0	-	-
13C12-DCB	209L	2000	4.0	-	-
Cleanup standards⁵					
13C12-3,4,4',5-TCB	81L	200	1.0	-	-
13C12-2,3,3',5,5'-PeCB	111L	1000	5.0	-	-
Internal standards⁶					
13C12-2,2',5,5'-TCB	52L	1000	-	-	-
13C12-2,2',4,5,5'-PeCB	101L	1000	-	-	-
13C12-2,2',3,4,4',5'-HxCB	138L	1000	-	-	-
13C12-2,2',3,3',5,5',6-HpCB	178L	1000	-	-	-

¹ Section 7.10-prepared in nonane and diluted to prepare spiking solution

² Section 7.10.3-prepared in acetone from stock solution daily

³ Section 7.9-prepared in nonane and diluted to prepare spiking solution. Concentrations are adjusted for expected background levels.

⁴ Section 7.14-prepared in acetone from stock solution daily. Concentrations are adjusted for expected background levels.

⁵ Section 7.11-prepared in nonane and added to extract prior to cleanup

⁶ Section 7.12-prepared in nonane and added to concentrated extract prior to injection

Table 4. Concentrations of PCBs in Calibration and Calibration Verification Solutions

Toxic PCB congener	IUPAC ¹ No.	CS1 (ng/mL)	CS2 (ng/mL)	CS3 ² (ng/mL)	CS4 (ng/mL)	CS5 (ng/mL)
3,3',4,4'-TCB	77	0.5	2	10	40	200
2,3,3',4,4'-PeCB	105	2.5	10	50	200	1000
2,3,4,4',5-PeCB	114	2.5	10	50	200	1000
2,3',4,4',5-PeCB	118	2.5	10	50	200	1000
2',3,4,4',5-PeCB	123	2.5	10	50	200	1000
3,3',4,4',5-PeCB	126	2.5	10	50	200	1000
2,3,3',4,4',5-HxCB	156	5	20	100	400	2000
2,3,3',4,4',5'-HxCB	157	5	20	100	400	2000
2,3',4,4',5,5'-HxCB	167	5	20	100	400	2000
3,3',4,4',5,5'-HxCB	169	5	20	100	400	2000
2,2',3,3',4,4',5-HpCB	170	5	20	100	400	2000
2,2',3,4,4',5,5'-HpCB	180	5	20	100	400	2000
2,3,3',4,4',5,5'-HpCB	189	5	20	100	400	2000
Labeled congener						
13C12-3,3',4,4'-TCB	77L	100	100	100	100	100
13C12-2,3,3',4,4'-PeCB	105L	100	100	100	100	100
13C12-2,3',4,4',5-PeCB	118L	100	100	100	100	100
13C12-3,3',4,4',5-PeCB	126L	100	100	100	100	100
13C12-2,3,3',4,4',5-HxCB	156L	100	100	100	100	100
13C12-2,3,3',4,4',5'-HxCB	157L	100	100	100	100	100
13C12-3,3',4,4',5,5'-HxCB	169L	100	100	100	100	100
13C12-2,2',3,4,4',5,5'-HpCB	180L	100	100	100	100	100
13C12-2,3,3',4,4',5,5'-HpCB	189L	100	100	100	100	100
13C12-DCB	209L	200	200	200	200	200
Cleanup standards						
13C12-3,4,4',5-TCB	81L	0.5	2	10	40	200
13C12-2,3,3',5,5'-PeCB	111L	2.5	10	50	200	1000
Internal standards						
13C12-2,2',5,5'-TCB	52L	100	100	100	100	100
13C12-2,2',4,5,5'-PeCB	101L	100	100	100	100	100
13C12-2,2',3,4,4',5'-HxCB	138L	100	100	100	100	100
13C12-2,2',3,3',5,5',6-HpCB	178L	100	100	100	100	100

¹ Suffix "L" indicates labeled compound² Section 15.3, calibration verification solution

Table 5. GC Retention Time Window Defining Solution and Congener Specificity Test Standard^{1,2}
(Section 7.15)

Congener Group	First eluted ³		Last eluted	
	Retention Time	Substituents	Retention Time	Substituents
TCB	54	2,2',6,6'	77	3,3',4,4'
PeCB	104	2,2',4,6,6'	126	3,3',4,4',5
HxCB	155	2,2',4,4',6,6'	169	3,3',4,4',5,5'
HpCB	188	2,2',3,4',5,6,6'	189	2,3,3',4,4',5,5'

SPB-Octyl resolution test compounds

123	2',3,4,4',5-PeCB
118	2,3',4,4',5-PeCB
114	2,3,4,4',5-PeCB

DB-1 column resolution test compounds

156	2,3,3',4,4',5-HxCB
157	2,3,3',4,4',5'-HxCB

¹ All compounds are at a concentration of 100 ng/mL in nonane.

² It is not necessary to monitor for the earliest eluted compounds if the toxic PCBs only are to be determined. If the co-planar PCBs (77, 126, 169) only are to be determined, it is necessary to resolve these co-planar PCBs and potentially interfering compounds only; i.e., use of the compounds listed in this Table is not required.

³ The earliest eluted compound in each congener group is provided for those instances in which all PCBs in that congener group are to be determined. If the toxic PCBs only (Table 1) are to be determined, use of the first eluted compounds is not required.

Table 6. Preliminary Acceptance Criteria for Performance Tests When All Toxic PCBs are Tested¹

Congener	IUPAC No.	Test (ng/mL)	IPR		OPR (ng/mL)	VER (ng/mL)
			s ² (ng/mL)	X ³ (ng/mL)		
3,3',4,4'-TCB	77	20	5.6	16-26	14-32	16-26
2,3,3',4,4'-PeCB	105	1000	172	720-1500	680-1600	780-1300
2,3,4,4',5'-PeCB	114	1000	390	160-2800	130-3300	770-1300
2,3',4,4',5'-PeCB	118	1000	172	720-1500	680-1600	780-1300
2',3,4,4',5'-PeCB	123	1000	390	160-2800	130-3300	770-1300
3,3',4,4',5'-PeCB	126	100	17	72-150	68-160	78-130
2,3,3',4,4',5'-HxCB	156	1000	222	740-1600	640-1700	780-1300
2,3,3',4,4',5'-HxCB	157	1000	222	740-1600	640-1700	780-1300
2,3',4,4',5,5'-HxCB	167	1000	222	740-1600	640-1700	780-1300
3,3',4,4',5,5'-HxCB	169	200	45	148-320	128-340	156-260
2,2',3,3',4,4',5'-HpCB	170	200	33	152-260	140-280	172-232
2,2',3,4,4',5,5'-HpCB	180	1000	165	760-1300	700-1400	860-1160
2,3,3',4,4',5,5'-HpCB	189	200	33	152-260	140-280	172-232
13C12-3,3',4,4'-TCB	77L	100	37	28-134	20-175	71-140
13C12-2,3,3',4,4'-PeCB	105L	100	39	16-279	13-328	77-130
13C12-2,3',4,4',5'-PeCB	118L	100	39	16-279	13-328	77-130
13C12-3,3',4,4',5'-PeCB	126L	100	39	16-279	13-328	77-130
13C12-2,3,3',4,4',5'-HxCB	156L	100	34	24-157	17-205	70-143
13C12-2,3,3',4,4',5'-HxCB	157L	100	43	24-157	17-205	70-143
13C12-3,3',4,4',5,5'-HxCB	169L	100	43	24-157	17-205	70-143
13C12-2,2',3,4,4',5,5'-HpCB	180L	100	41	28-141	20-186	72-138
13C12-2,3,3',4,4',5,5'-HpCB	189L	200	82	56-282	40-372	144-276
Cleanup standards						
13C12-3,4,4',5'-TCB	81L	20	7.2	8-31	6-38	15-26
13C12-2,3,3',5,5'-PeCB	111L	100	36	39-154	31-191	79-127

Table 6a. Preliminary Acceptance Criteria for Performance Tests when PCBs 77, 126, and 169 only are Tested¹

Native PCB	IUPAC	Test (ng/mL)	IPR		OPR (ng/mL)	VER (ng/mL)
			s ² (ng/mL)	X ³ (ng/mL)		
3,3',4,4'-TCB	77	20	5.4	17-25	15-30	16-25
3,3',4,4',5'-PeCB	126	100	17	72-150	68-160	78-130
3,3',4,4',5,5'-HxCB	169	200	45	148-320	128-340	156-260
13C12-3,3',4,4'-TCB	77L	100	34	32-115	25-141	76-131
13C12-3,3',4,4',5'-PeCB	126L	100	17	72-150	68-160	78-130
13C12-3,3',4,4',5,5'-HxCB	169L	200	45	148-320	128-340	156-260
Cleanup standards						
13C12-3,4,4',5'-TCB	81L	20	7.2	8-31	6-38	15-26
13C12-2,3,3',5,5'-PeCB	111L	100	36	39-154	31-191	79-127

¹ Preliminary criteria transferred from Method 1613. All criteria given as concentration in the final extract, assuming a 20- μ L volume.

² s=standard deviation

³ X=average concentration

Table 7. Labeled Compound Recovery in Samples When All PCBs are Tested

Labeled PCB	IUPAC No.	Test conc (ng/mL)	Labeled compound recovery	
			(ng/mL)	(%)
13C12-3,3',4,4'-TCB	77	100	24-169	24-169
13C12-2,3,3',4,4'-PeCB	105	100	21-178	21-178
13C12-2,3',4,4',5-PeCB	118	100	21-178	21-178
13C12-3,3',4,4',5-PeCB	126	100	21-178	21-178
13C12-2,3,3',4,4',5-HxCB	156	100	26-152	26-152
13C12-2,3,3',4,4',5'-HxCB	157	100	26-152	26-152
13C12-2,3',4,4',5,5'-HxCB	167	100	26-152	26-152
13C12-3,3',4,4',5,5'-HxCB	169	100	26-152	26-152
13C12-2,2',3,4,4',5,5'-HpCB	180	100	23-143	23-143
13C12-2,3,3',4,4',5,5'-HpCB	189	100	23-143	23-143
Cleanup standards				
13C12-3,4,4',5-TCB	81	20	7-40	35-197
13C12-2,3,3',5,5'-PeCB	111	100	35-197	35-197

Table 7a. Labeled Compound Recovery When PCBs 77, 126, and 169 Only are Tested¹

Labeled PCB	IUPAC No.	Test conc (ng/mL)	Labeled compound Recovery	
			(ng/mL)	(%)
13C12-3,3',4,4'-TCB	77	100	29-140	29-140
13C12-3,3',4,4',5-PeCB	126	100	21-178	21-178
13C12-3,3',4,4',5,5'-HxCB	169	100	26-152	26-152
Cleanup standards				
13C12-3,4,4',5-TCB	81	20	8-33	42-164
13C12-2,3,3',5,5'-PeCB	111	100	35-197	35-197

¹ Preliminary criteria transferred from Method 1613. Criteria are given as concentration in the final extract, assuming a 20 uL volume.

Table 8. Descriptors, Exact m/z's, m/z Types, and Elemental Compositions of the PCBs

Descriptor	Exact m/z ¹	m/z type	Elemental composition	Substance ²
1.	289.9224	M	C12 H6 35Cl4	TCB
	291.9194	M+2	C12 H6 35Cl3 37Cl4	TCB
	292.9825	Lock	C7 F11	PFK
	301.9626	M	¹³ C12 H6 35Cl4	PeCB ³
	303.9597	M+2	¹³ C12 H6 35Cl3 37Cl	PeCB ³
	325.8804	M+2	C12 H5 35Cl4 37Cl	PeCB
	327.8775	M+4	C12 H5 35Cl3 37Cl2	PeCB
	330.9792	QC	C7 F13	PFK
2.	325.8804	M+2	C12 H5 35Cl4 37Cl	PeCB
	327.8775	M+4	C12 H5 35Cl3 37Cl2	PeCB
	337.9207	M+2	¹³ C12 H5 35Cl4 37Cl	PeCB ³
	339.9178	M+4	¹³ C12 H5 35Cl3 37Cl2	PeCB ³
	354.9892	Lock	C9 F13	PFK
	359.8415	M+2	C12 H4 35Cl5 37Cl	HxCB
	361.8385	M+4	C12 H4 35Cl4 37Cl2	HxCB
	371.8817	M+2	¹³ C12 H4 35Cl5 37Cl	HxCB ³
	373.8788	M+4	¹³ C12 H4 35Cl4 37Cl2	HxCB ³
	393.8025	M+2	C12 H3 35Cl6 37Cl	HpCB
	395.7996	M+4	C12 H3 35Cl5 37Cl2	HpCB
	405.8428	M+2	¹³ C12 H3 35Cl6 37Cl	HpCB ³
	407.8398	M+4	¹³ C12 H3 35Cl5 37Cl2	HpCB ³
	3.	442.9728	Lock	C10 F17
509.7229		M+4	¹³ C12 35Cl10 37Cl2	DCB ³
511.7199		M+6	¹³ C12 35Cl9 37Cl3	DCB ³
513.7170		M+8	¹³ C12 35Cl8 37Cl4	DCB ³

¹ Nuclidic masses used were:

H = 1.007825

C = 12.00000

¹³C = 13.003355

³⁵Cl = 34.968853

³⁷Cl = 36.965903

² TCB = Tetrachlorobiphenyl

PeCB = Pentachlorobiphenyl

HxCB = Hexachlorobiphenyl

HpCB = Heptachlorobiphenyl

DCB = Decachlorobiphenyl

³ ¹³C labeled compound

Table 9. Theoretical Ion Abundance Ratios and QC Limits

Chlorine atoms	m/z's forming ratio	Theoretical ratio	QC Limit ¹	
			Lower	Upper
4	M/(M+2)	0.77	0.65	0.89
5	(M+2)/(M+4)	1.55	1.32	1.78
6	M/(M+2)	0.51	0.43	0.59
6	(M+2)/(M+4)	1.24	1.05	1.43
7	M/(M+2)	0.44	0.37	0.51
7	(M+2)/(M+4)	1.05	0.88	1.20
8	(M+2)/(M+4)	0.89	0.76	1.02

¹ QC limits represent +/- 15 % windows around the theoretical ion abundance ratio. These limits are preliminary.

Table 10. Suggested Sample Quantities to be Extracted for Various Matrices¹

Sample matrix ²	Example	Percent solids	Phase	Quantity extracted
Single-phase				
Aqueous	Drinking water	<1	— ³	1000 mL
	Groundwater			
	Treated wastewater			
Solid	Dry soil	>20	Solid	10 g
	Compost			
	Ash			
Organic	Waste solvent	<1	Organic	10 g
	Waste oil			
	Organic polymer			
Tissue	Fish	—	Organic	10 g
	Human adipose			
Multi-phase				
Liquid/Solid				
Aqueous/Solid	Wet soil	1-30	Solid	10 g
	Untreated effluent			
	Digested municipal sludge			
	Filter cake			
	Paper pulp			
Organic/solid	Industrial sludge	1-100	Both	10 g
	Oily waste			
Liquid/Liquid				
Aqueous/organic	In-process effluent	<1	Organic	10 g
	Untreated effluent			
	Drum waste			
Aqueous/organic/solid	Untreated effluent	>1	Organic & solid	10 g
	Drum waste			

¹ The quantity of sample to be extracted is adjusted to provide 10 g of solids (dry weight). One liter of aqueous samples containing one percent solids will contain 10 grams of solids. For aqueous samples containing greater than one percent solids, a lesser volume is used so that 10 grams of solids (dry weight) will be extracted.

² The sample matrix may be amorphous for some samples. In general, when the PCBs are in contact with a multiphase system in which one of the phases is water, they will be preferentially dispersed in or adsorbed on the alternate phase because of their low solubility in water.

³ Aqueous samples are filtered after spiking with the labeled compounds. The filtrate and the materials trapped on the filter are extracted separately, and the extracts are combined for cleanup and analysis.

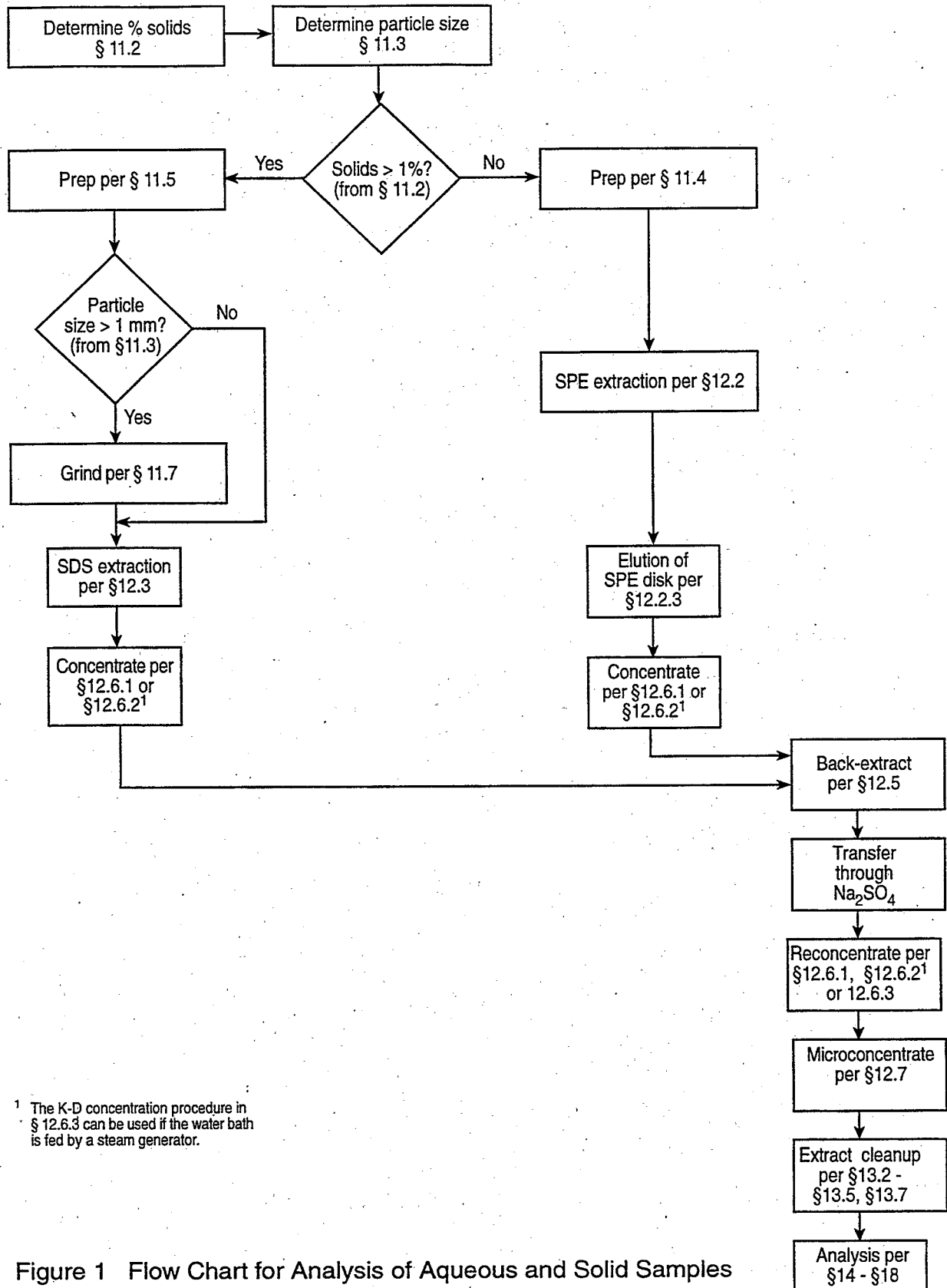

¹ The K-D concentration procedure in § 12.6.3 can be used if the water bath is fed by a steam generator.

Figure 1 Flow Chart for Analysis of Aqueous and Solid Samples

52-001-126

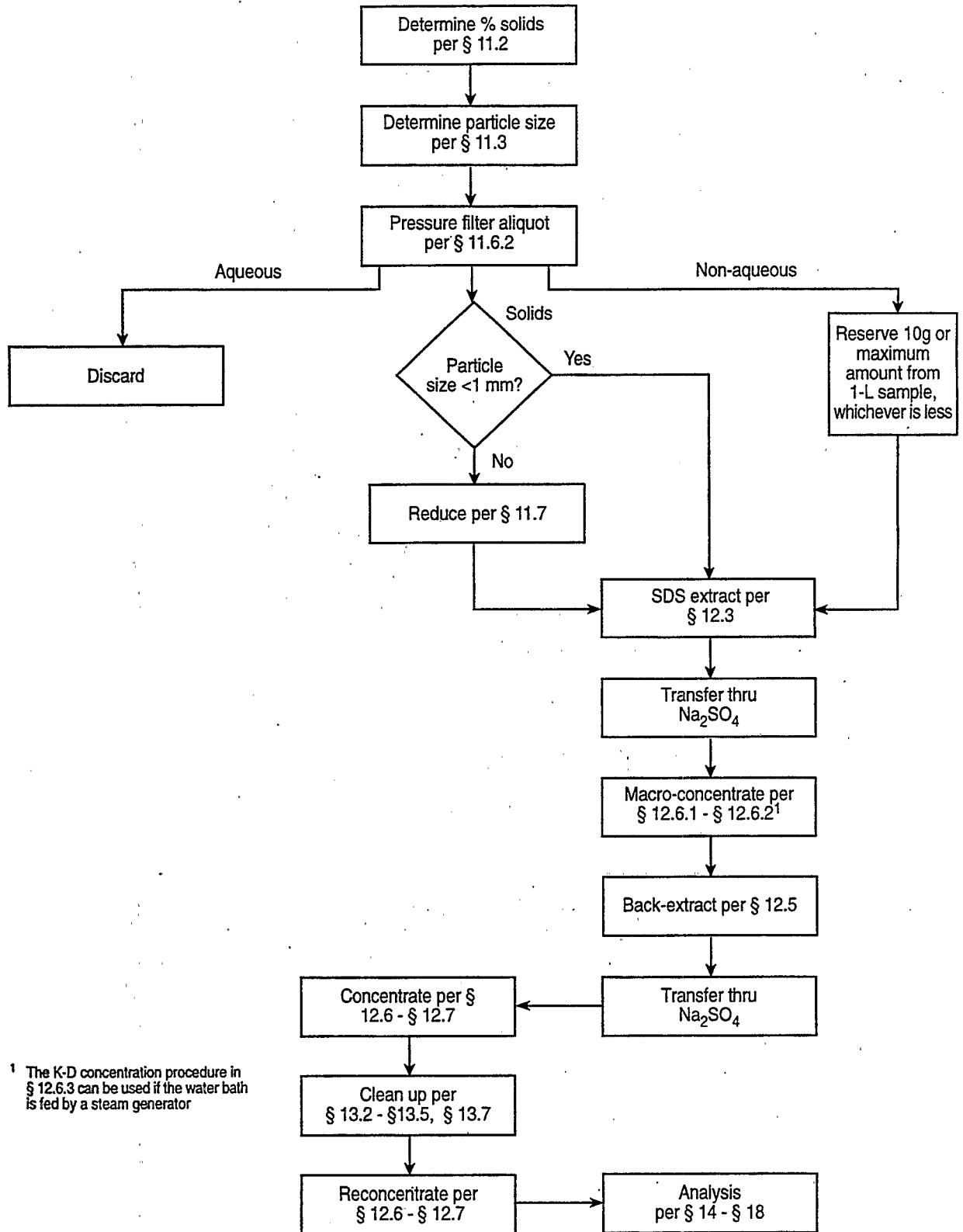

¹ The K-D concentration procedure in § 12.6.3 can be used if the water bath is fed by a steam generator

Figure 2 Flow Chart for Analysis of Multi-Phase Samples

52-001-127

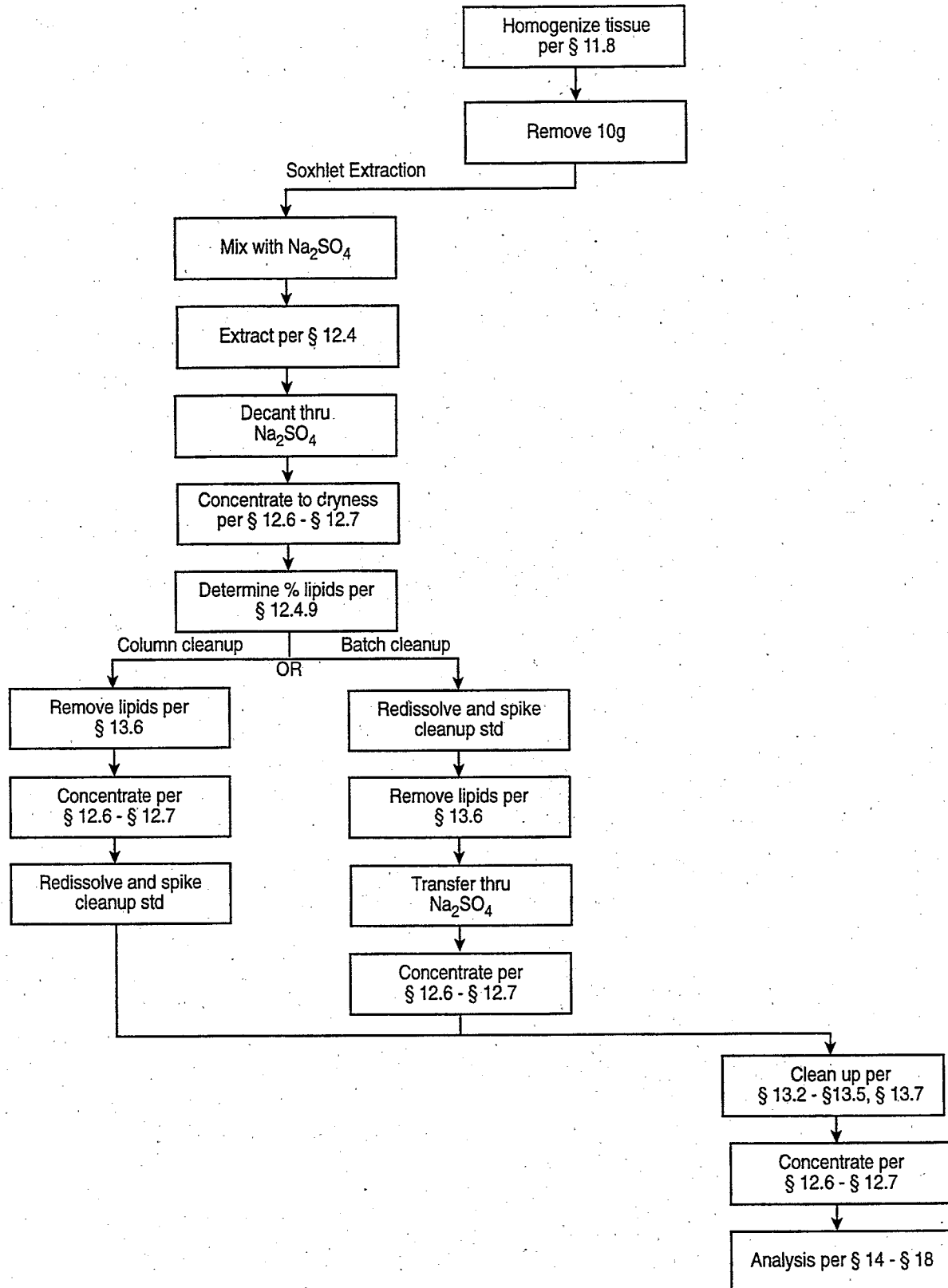

Figure 3 Flow Chart for Analysis of Tissue Samples

52-001-128

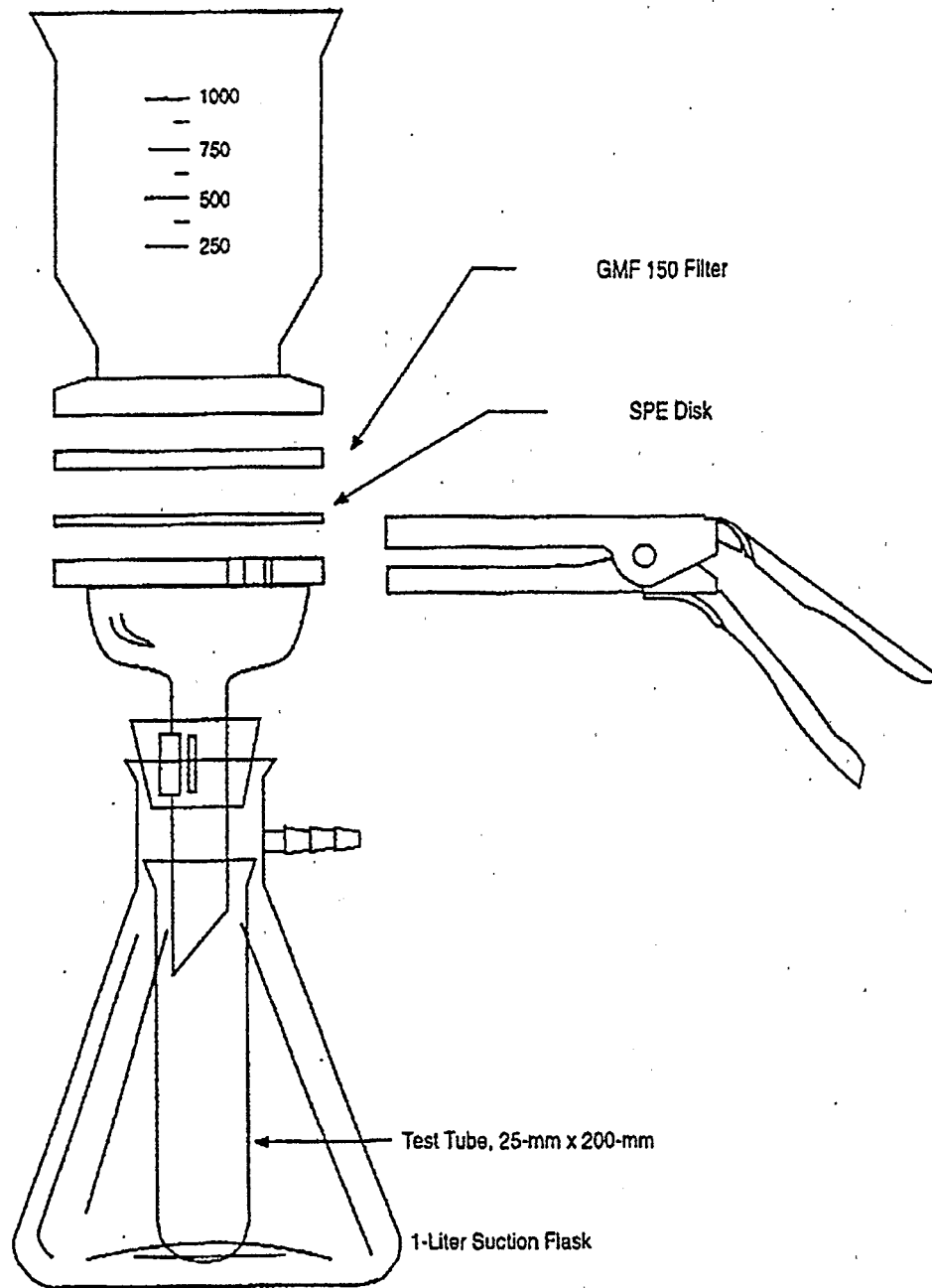
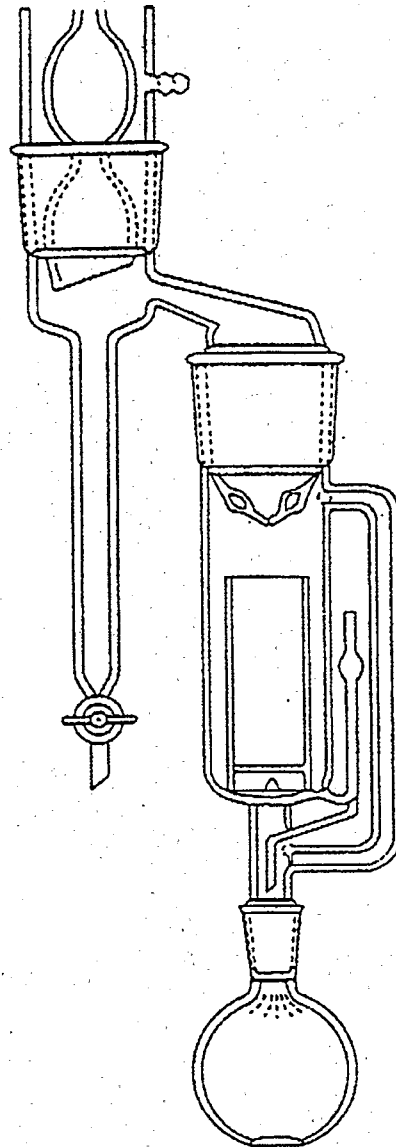

Figure 4 Solid-phase Extraction Apparatus



52-027-02

Figure 5 Soxhlet/Dean-Stark Extractor

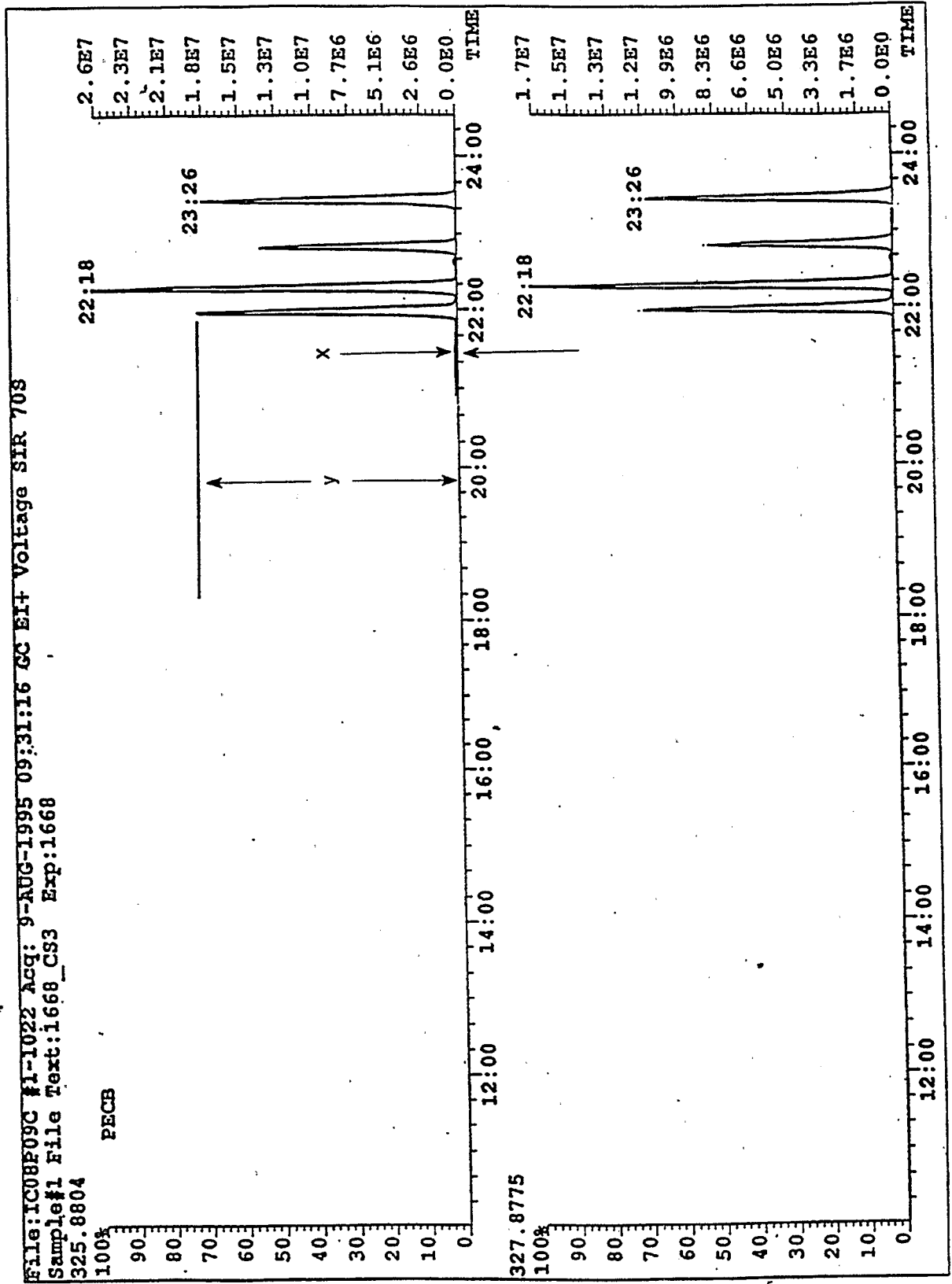

Figure 6

Congener-Specific Separation of Resolution Test Compounds on SPB-Octyl Column

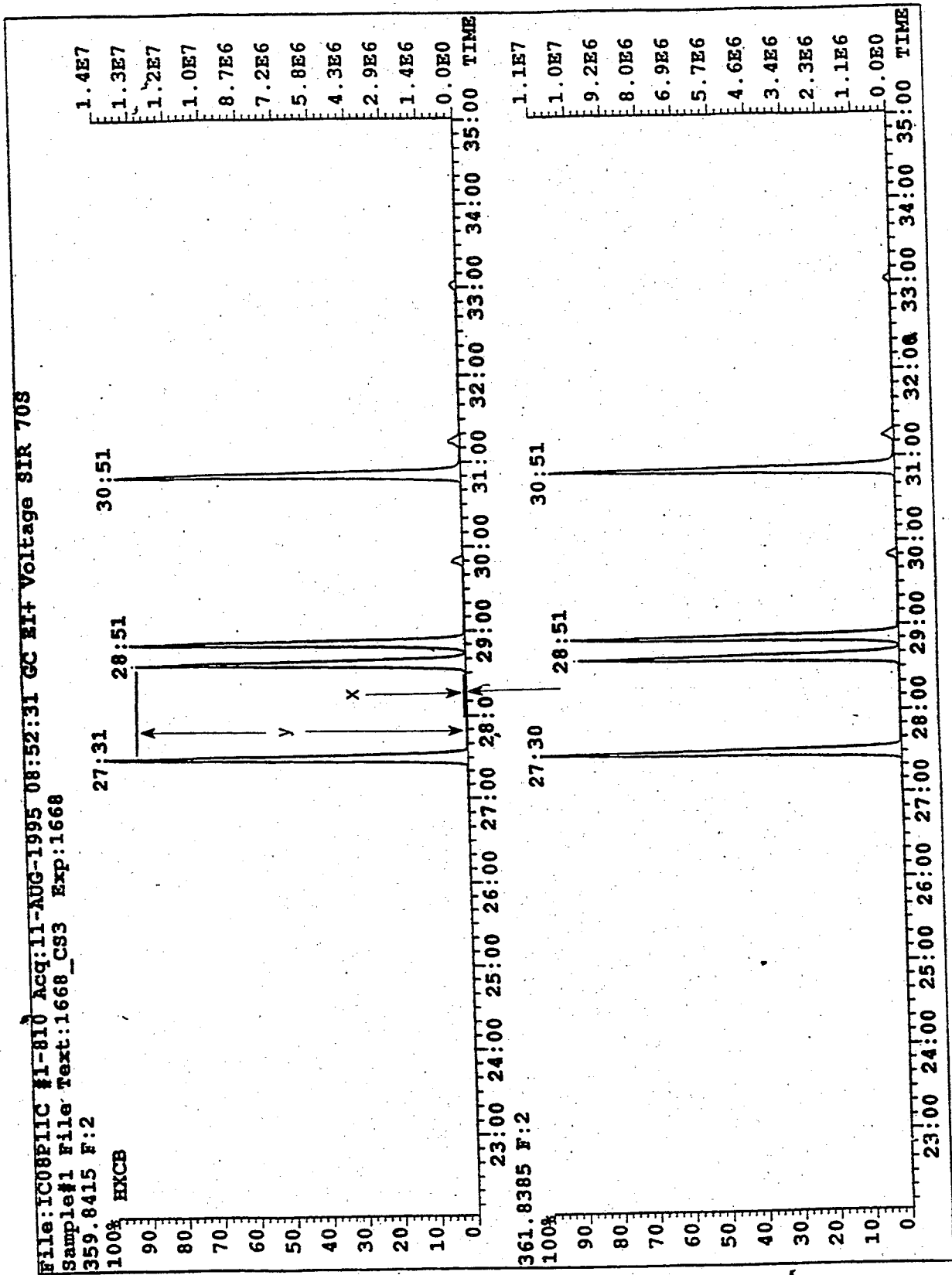

Figure 7 Congener-Specific Separation of PCBs 156 and 17 on DB-1 Column

24.0 Glossary of Definitions and Purposes

These definitions and purposes are specific to this method but have been conformed to common usage as much as possible.

24.1 Units of weight and measure and their abbreviations

24.1.1 Symbols

°C	degrees Celsius
µL	microliter
µm	micrometer
<	less than
>	greater than
%	percent

24.1.2 Alphabetical abbreviations

amp	ampere
cm	centimeter
g	gram
h	hour
ID	inside diameter
in.	inch
L	liter
M	Molecular ion
m	meter
mg	milligram
min	minute
mL	milliliter
mm	millimeter
m/z	mass-to-charge ratio
N	normal; gram molecular weight of solute divided by hydrogen equivalent of solute, per liter of solution
OD	outside diameter
pg	picogram
ppb	part-per-billion
ppm	part-per-million
ppq	part-per-quadrillion
ppt	part-per-trillion
psig	pounds-per-square inch gauge
v/v	volume per unit volume
w/v	weight per unit volume

24.2 Definitions and acronyms (in alphabetical order).

Analyte: A PCB tested for by this method. The analytes are listed in Table 1.

Calibration standard (CAL): A solution prepared from a secondary standard and/or stock solutions and used to calibrate the response of the instrument with respect to analyte concentration.

Calibration verification standard (VER): The mid-point calibration standard (CS3) that is used in to verify calibration. See Table 4.

CS1, CS2, CS3, CS4, CS5: See Calibration standards and Table 4.

DCB: Decachlorobiphenyl (PCB 209)

Field blank: An aliquot of reagent water or other reference matrix that is placed in a sample container in the laboratory or the field, and treated as a sample in all respects, including exposure to sampling site conditions, storage, preservation, and all analytical procedures. The purpose of the field blank is to determine if the field or sample transporting procedures and environments have contaminated the sample.

GC: Gas chromatograph or gas chromatography.

GPC: Gel permeation chromatograph or gel permeation chromatography.

HpCB: Heptachlorobiphenyl

HPLC: High performance liquid chromatograph or high performance liquid chromatography.

HRGC: High resolution GC.

HRMS: High resolution MS.

HxCB: Hexachlorobiphenyl

IPR: Initial precision and recovery; four aliquots of the diluted PAR standard analyzed to establish the ability to generate acceptable precision and accuracy. An IPR is performed prior to the first time this method is used and any time the method or instrumentation is modified.

K-D: Kuderna-Danish concentrator; a device used to concentrate the analytes in a solvent.

Laboratory blank: See Method blank.

Laboratory control sample (LCS): See Ongoing precision and recovery standard (OPR).

Laboratory reagent blank: See Method blank.

May: This action, activity, or procedural step is neither required nor prohibited.

May not: This action, activity, or procedural step is prohibited.

Method blank: An aliquot of reagent water that is treated exactly as a sample including exposure to all glassware, equipment, solvents, reagents, internal standards, and surrogates that are used with samples. The method blank is used to determine if analytes or interferences are present in the laboratory environment, the reagents, or the apparatus.

Minimum level (ML): The level at which the entire analytical system must give a recognizable signal and acceptable calibration point for the analyte. It is equivalent to the concentration of the lowest calibration standard, assuming that all method-specified sample weights, volumes, and cleanup procedures have been employed.

MS: Mass spectrometer or mass spectrometry.

Must: This action, activity, or procedural step is required.

OPR: Ongoing precision and recovery standard (OPR); a laboratory blank spiked with known quantities of analytes. The OPR is analyzed exactly like a sample. Its purpose is to assure that the results produced by the laboratory remain within the limits specified in this method for precision and recovery.

PAR: Precision and recovery standard; secondary standard that is diluted and spiked to form the IPR and OPR.

PFK: Perfluorokerosene; the mixture of compounds used to calibrate the exact m/z scale in the HRMS.

Preparation blank: See Method blank.

Primary dilution standard: A solution containing the specified analytes that is purchased or prepared from stock solutions and diluted as needed to prepare calibration solutions and other solutions.

Quality control check sample (QCS): A sample containing all or a subset of the analytes at known concentrations. The QCS is obtained from a source external to the laboratory or is prepared from a source of standards different from the source of calibration standards. It is used to check laboratory performance with test materials prepared external to the normal preparation process.

PeCB: Pentachlorobiphenyl

PCB: Polychlorinated biphenyl

Reagent water: water demonstrated to be free from the analytes of interest and potentially interfering substances at the method detection limit for the analyte.

Relative standard deviation (RSD): The standard deviation times 100 divided by the mean. Also termed "coefficient of variation."

RF: Response factor. See Section 10.6.1.

RR: Relative response. See Section 10.5.2.

RSD: See Relative standard deviation.

SDS: Soxhlet/Dean-Stark extractor; an extraction device applied to the extraction of solid and semi-solid materials (Reference 12 and Figure 5).

Should: This action, activity, or procedural step is suggested but not required.

SICP: Selected ion current profile; the line described by the signal at an exact m/z.

SPE: Solid-phase extraction; an extraction technique in which an analyte is extracted from an aqueous sample by passage over or through a material capable of reversibly adsorbing the analyte. Also termed liquid-solid extraction.

Specificity: The ability to measure an analyte of interest in the presence of interferences and other analytes of interest encountered in a sample.

Stock solution: A solution containing an analyte that is prepared using a reference material traceable to EPA, the National Institute of Science and Technology (NIST), or a source that will attest to the purity and authenticity of the reference material.

TCB: Tetrachlorobiphenyl.

VER: See Calibration verification standard.

Annex XX:

Maximum levels for certain foodstuffs (EC Regulations)

Maximum Levels of Heavy Metals – (EC) Regulation 1881/2006

Maximum levels for certain foodstuffs (EC Regulations)**Maximum Levels of Heavy Metals – (EC) Regulation 1881/2006**

	Foodstuffs	Maximum levels $\mu\text{g kg}^{-1}$ wet weight		
		Cadmium	Lead	Mercury
1	Muscle meat of fish ⁽¹⁾	0.050 Excluding species listed in 2 and 3	0.30	0.50 Excluding species listed in 4
2	Muscle meat of the following fish ⁽¹⁾ anchovy (<i>Engraulis species</i>) bonito (<i>Sarda sarda</i>) common two-banded seabream (<i>Diplodus vulgaris</i>) eel (<i>Anguilla anguilla</i>) grey mullet (<i>Mugil labrosus labrosus</i>) horse mackerel or scad (<i>Trachurus species</i>) louvar or luvar (<i>Luvarus imperialis</i>) sardine (<i>Sardina pilchardus</i>) sardinops (<i>Sardinops species</i>) tuna (<i>Thunnus species</i> , <i>Euthynnus species</i> , <i>Katsuwonus pelamis</i>) wedge sole (<i>Dicologlossa cuneata</i>)	0.10		
3	Muscle meat of swordfish (<i>Xiphias gladius</i>) ⁽¹⁾	0.30		
4	Muscle meat of the following fish: anglerfish (<i>Lophius species</i>) atlantic catfish (<i>Anarhichas lupus</i>) bonito (<i>Sarda sarda</i>) eel (<i>Anguilla species</i>) emperor, orange roughy, rosy soldierfish (<i>Hoplostethus species</i>) grenadier (<i>Coryphaenoides rupestris</i>) halibut (<i>Hippoglossus hippoglossus</i>) marlin (<i>Makaira species</i>) megrim (<i>Lepidorhombus species</i>) mullet (<i>Mullus species</i>) pike (<i>Esox lucius</i>)			1.0

	plain bonito (<i>Orcynopsis unicolor</i>) poor cod (<i>Tricopterus minutes</i>) portuguese dogfish (<i>Centroscymnus coelolepis</i>) rays (<i>Raja species</i>) redfish (<i>Sebastes marinus</i> , <i>S. mentella</i> , <i>S. viviparus</i>) sail fish (<i>Istiophorus platypterus</i>) scabbard fish (<i>Lepidopus caudatus</i> , <i>Aphanopus carbo</i>) seabream, pandora (<i>Pagellus species</i>) shark (all species) snake mackerel or butterfish (<i>Lepidocybium flavobrunneum</i> , <i>Ruvettus pretiosus</i> , <i>Gempylus serpens</i>) sturgeon (<i>Acipenser species</i>) swordfish (<i>Xiphias gladius</i>) tuna (<i>Thunnus species</i> , <i>Euthynnus species</i> , <i>Katsuwonus pelamis</i>)			
5	Crustaceans, excluding brown meat of crab and excluding head and thorax meat of lobster and similar large crustaceans	0.50	0.50	0.50
6	Bivalve molluscs	1.0	1.5	
7	Cephalopods (without viscera)	1.0	1.0	

(1) Exclusion of liver. Where fish are intended to be eaten whole, the maximum level shall apply to the whole fish

Maximum Levels of

Benzo(a)pyrene and sum of four PAHs (benzo(a)pyrene, benz(a)anthracene, benzo(b)fluoranthene and chrysene) Regulation No 835/2011 amending Regulation (EC) 1881/2006

Foodstuffs	Maximum levels ($\mu\text{g kg}^{-1}$)	
	Benzo(a)pyrene	Sum of benzo(a)pyrene, benz(a)anthracene, benzo(b)fluoranthene and chrysene *
Bivalve molluscs (fresh, chilled or frozen)	5.0	30.0

* Lower bound concentrations are calculated on the assumption that all the values of the four substances below the limit of quantification are zero

Maximum Levels of

Dioxins and PCBs - Regulation (EC) 1259/2011 amending Regulation (EC) 1881/2006

Foodstuffs	Maximum levels		
	Sum of dioxins (WHO-PCDD/F-TEQ) ⁽¹⁾	Sum of dioxins and dioxin-like PCBs (WHO-PCDD/F-PCB-TEQ) ⁽¹⁾	Sum of PCB28, PCB52, PCB101, PCB138, PCB153 and PCB180 (ICES 6)
Muscle meat of fish and fishery products and products thereof ⁽²⁾ with the exemption of: <ul style="list-style-type: none"> • wild caught eel • wild caught fresh water fish, with the exception of diadromous fish species caught in fresh water • fish liver and derived products • marine oils The maximum level for crustaceans applies to muscle meat from appendages and abdomen. In case of crabs and crab-like crustaceans (<i>Brachyura</i> and <i>Anomura</i>) it applies to muscle meat from appendages.	3.5 pg g ⁻¹ wet weight	6.5 pg g ⁻¹ wet weight	75 ng g ⁻¹ wet weight

(1) Dioxins (sum of polychlorinated dibenzo-para-dioxins (PCDDs) and polychlorinated dibenzofurans (PCDFs), expressed as World Health Organisation (WHO) toxic equivalent using the WHO-toxic equivalency factors (WHO-TEFs)) and sum of dioxins and dioxin-like PCBs (sum of PCDDs, PCDFs and polychlorinated biphenyls (PCBs), expressed as WHO toxic equivalent using the WHO-TEFs). WHO-TEFs for human risk assessment based on the conclusions of the World Health Organization (WHO) (For TEF values see note 31, (EC) Regulation 1259/2011 – Annex 1.1.9).

(2) Where fish are intended to be eaten whole, the maximum level shall apply to the whole fish.

Annex XXI:

References

References

Black, K., Kalantzi, I., Karakassis, I., Papageorgiou, N., Pergantis, S., Shimmield, T. (2013). Heavy metals, trace elements and sediment geochemistry at four Mediterranean fish farms, *Science of the Total Environment*. 444, 128–137.

CEN (1997) European Standard EN 1948: Stationary source emissions, determination of the mass concentration of PCDDs/PCDFs. CEN, Brussels, Belgium

Charles M.J, Green B., Tondeur J.R, Hass R. (1989). Optimisation of a hybrid-mass spectrometer method for the analysis of polychlorinated dibenzo-p-dioxins and polychlorinated dibenzofurans. *Chemosphere* 19, 51–57

Codex Alimentarius (FAO/WHO) : <http://www.fao.org/fao-who-codexalimentarius>

Commission Regulation (EU) No 835/2011 amending Regulation (EC) No 1881/2006 as regards maximum levels for polycyclic aromatic hydrocarbons in foodstuffs

Enamorado-Báez, S.M., Abril, JM and Gómez-Guzmán, JM (2013) Determination of 25 Trace Element Concentrations in Biological Reference Materials by ICP-MS following Different Microwave-Assisted Acid Digestion Methods Based on Scaling Masses of Digested Samples. *Hindawi Publishing Corporation, ISRN Analytical Chemistry, Volume 2013, Article ID 851713, 14 pages.* <http://dx.doi.org/10.1155/2013/851713>

EU Commission Regulation (EC) No 333/2007, laying down the methods of sampling and analysis for the official control of the levels of lead, cadmium, mercury, inorganic tin, 3-MCPD and benzo(a)pyrene in foodstuffs

EU Commission Regulation (EC) 836/2011 amending Commission Regulation (EC) No 333/2007, laying down the methods of sampling and analysis for the official control of the levels of lead, cadmium, mercury, inorganic tin, 3-MCPD and benzo(a)pyrene in foodstuffs

EU Commission Regulation (EC) No 1259/2011, amending Regulation (EC) No 1881/2006 as regards maximum levels for dioxins, dioxin-like PCBs and non-dioxin-like PCBs in foodstuffs (Annex IV);

EU Commission Regulation (EC) No 1881/2006, setting maximum levels for certain contaminants in seafood (Annex I)

Focant J.F, Pirard C, Eppe G, DePauw E. (2005). Recent advances in mass spectrometric measurement of dioxins *J. Chromatography A*. 1067:265–275

Harms, U. 1985. Possibilities of improving the determination of extremely low lead concentrations in marine fish by graphite furnace atomic absorption spectrometry. *Fresenius Journal of Analytical Chemistry*, 322: 53-56.

HELCOM (2012a). Manual for marine monitoring in the COMBINE programme. Annex B-12, Appendix 4: Technical note on the determination of trace metallic elements in biota

HELCOM (2012b). COMBINE Annex B-12, Appendix 4, Attachment 1. Technical note on the determination of Total Mercury in marine biota by Cold Vapour Atomic Absorption Spectroscopy

HELCOM (2012c). Manual for marine monitoring in the COMBINE programme. Annex B-12, Appendix 3. Technical note on the determination of chlorinated biphenyls and organochlorine pesticides in biota.

HELCOM (2012d). Manual for marine monitoring in the COMBINE programme. Annex B-12, Appendix 2. Technical Note on the determination of Polycyclic Aromatic Hydrocarbons in Biota

IAEA (2011a). Recommended method on microwave digestion of marine samples for the determination of trace element content (IAEA/Marine Environmental Studies Laboratory in co-operation with UNEP/MAP MED POL)

IAEA (2011b) Recommended method for the determination of selected trace element in samples of marine origin by flame atomic absorption spectrometry

IAEA (2011c) Recommended method for the determination of selected trace element in samples of marine origin by atomic absorption spectrometry using graphite furnace

IAEA (2012a) Recommended method on the determination of Total Hg in marine samples by Thermal Decomposition Amalgamation and Atomic Absorption Spectrometry

IAEA (2012b). Recommended method on the determination of Total Hg in samples of marine origin by Cold Vapour Atomic Absorption Spectrometry

ICES/OSPAR (2018). CEMP Guidelines for monitoring contaminants in biota and sediments. Technical Annex 3: Determination of parent and alkylated PAHs in biological materials

ISO (2004) ISO 18073: Water quality—Determination of tetraocta-chlorinated dioxins and furans—Method using isotope dilution HRGC/HRMS. International Organization for Standardization (ISO), Geneva, Switzerland

ISO (2006) ISO 17585: Water quality—Determination of dioxin-like polychlorinated biphenyls—method using gas chromatography and mass spectrometry. International Organization for Standardization (ISO), Geneva, Switzerland

Petrovic M., Eljarrat E., Lopez de Alda M.J, Barcelo D. (2002). Recent advances in the mass spectrometric analysis related to endocrine disrupting compounds in aquatic environmental samples. *J. Chromatography A* 974:23–51.

Reiner, E.J, Clement, R.E, Okey, A.B., Marvin, C.H. (2006). Advances in analytical techniques for polychlorinated dibenzo-p-dioxins, polychlorinated dibenzofurans and dioxin-like PCBs. *Anal Bioanal Chem* (2006) 386: 791–806.

Reiner E.J, Schellenberg D.H, Taguchi V.Y (1991). Environmental applications for the analysis of chlorinated dibenzo-p-dioxins and dibenzofurans using mass-spectrometry. *Environ Sci Technol* 25:110–117

Reiner E.J, Schellenberg D.H Taguchi V.Y, Mercer R.S, Townsend J.A, Thompson T.S, Clement R.E (1990). Application of tandem quadrupole mass spectrometry for ultra-trace determination of polychlorinated dibenzo-p-dioxins and dibenzofurans. *Chemosphere* 20, 1385-1392.

Richter B.E, Jones B.A, Ezzell J.L, Porter N.L, Avdalovic N, Pohl C (1996). Accelerated Solvent Extraction: A Technique for Sample Preparation. *Analytical Chemistry*, 68:1033–1039

Taylor KZ, Waddell DS, Reiner EJ, MacPherson KA (1995). Direct Elution of Solid Phase Extraction Disks for the Determination of Polychlorinated Dibenzo-p-dioxins and Polychlorinated Dibenzofurans in Effluent Samples. *Analytical Chemistry*, 67:1186–1190

Thomson, M. (2000). Recent trends in inter-laboratory precision at ppb and sub-ppb concentrations in relation to fitness for purpose criteria in proficiency testing. *Analyst* 125, 385-386

UNEP (2019). UNEP/MED WG.467/5. IMAP Guidance Factsheets: Update for Common Indicators 13, 14, 17, 18, 20 and 21: New proposal for candidate indicators 26 and 27

UNEP/IAEA (2011d). Sample work-up for the analysis of selected chlorinated hydrocarbons in the marine environment. Reference Methods for Marine Pollution Studies No 71.

US EPA (1994) US-EPA Method 200.8: Determination of trace elements in waters and wastes by inductively coupled plasma-mass spectrometry

US EPA (2007). U.S. Environmental Protection Agency, EPA method 7473, Mercury in solids and solutions by thermal decomposition, amalgamation and atomic absorption spectrophotometry Rev 0. <http://www.epa.gov/osw/hazard/testmethods/sw846/pdfs/7473.pdf>

US EPA (2007b). U.S. Environmental Protection Agency, EPA method 7473, Mercury in solids and solutions by thermal decomposition, amalgamation and atomic absorption spectrophotometry Rev 0. <http://www.epa.gov/osw/hazard/testmethods/sw846/pdfs/7473.pdf>

US EPA (2008) Method 1668, Revision B: Chlorinated biphenyl congeners in water, soil, sediment, and tissue by HRGC/HRMS, EPA-821-R-08-020. Office of Water, US Environmental Protection Agency, Washington, DC (Annex XVI)