

**RAIN AND STORM WATER HARVESTING
FOR ADDITIONAL WATER SUPPLY
IN RURAL AREAS**

Expert Group Meeting

30 October - 2 November 1979

Nairobi



UNITED NATIONS ENVIRONMENT PROGRAMME

UNITED NATIONS ENVIRONMENT PROGRAMME

RAIN AND STORM WATER HARVESTING FOR
ADDITIONAL WATER SUPPLY IN RURAL AREAS



Nairobi, 1979

UNITED NATIONS ENVIRONMENT PROGRAMME

RAIN AND STORM WATER HARVESTING FOR ADDITIONAL WATER SUPPLY IN RURAL AREAS

INTRODUCTION

This document summarises discussions held on reports of rain and storm water harvesting in Africa, Europe, Central America, Asia, the Middle East, China, Australia and the Pacific, by a group of consultants of the United Nations Environment Programme in Nairobi, 30 October to 2 November 1979.

WATER HARVESTING

Water harvesting here refers to the deliberate collection of rain water from a surface (catchment) and its storage to provide water supply. This is distinct from water running off naturally into perennial rivers to be controlled and stored in dams and reservoirs. At present there are various forms of water harvesting known world wide. There are also many regions where rainfall is heavy for part of the year and sparse for the rest of the year. Rain water and storm run-off harvested in season and stored would alleviate the problem of water shortage in the dry season.

The purpose of this activity was to bring together various technologies for water harvesting, select feasible and effective ones, and, in a follow-up field activity, assist communities in climatically suitable areas to implement programmes of harvesting for water supply. The information now collected by no means exhausts the existing experience, and the recommendations only represent the beginnings of bringing together methodologies which may be used to promote a wider application of the safe practice of water harvesting.

The information collected world-wide will be published in full by the United Nations Environment Programme. The present document summarises methods practised for collection, storage, treatment, distribution and use of storm water. In the follow-up activities it is intended, with the involvement of communities in climatically suitable areas, to promote the application of those methods which are feasible.

WATER HARVESTING IN HISTORY

Various forms of water harvesting have been practised for thousands of years. They involve simple but effective technologies. In some regions of the world, in ancient times, water harvesting was of enormous importance. Roman villas and cities were planned to take advantage of rain water for drinking and air conditioning. Fortresses built on mountain tops had arrangements to collect rain water for use when under siege, though in normal times water was carried up from the valley. In the hills above Bombay in India, the early Buddhist monastic cells had an intricate series of gutters and cisterns cut into the rock to provide domestic water on a round-the-year basis.

Today, rain water provides the only source of water supply on some tropical islands. But in many parts of the world where water systems have been installed, rain water harvesting is no longer extensively practised. In many developing countries, it is still used as a way of supplementing the normal water supply. In communities in Uganda, for example, where piped water is available but at some distance from individual houses, the household rain water tank provides easy access to clean water at very low cost.

RAIN WATER HARVESTING TECHNOLOGY

The technologies described in this section are suitable for rain water collection for domestic use by households or small communities, but they may also be used in a small way for agricultural purposes. The technologies along with evaluation criteria and specific recommendations will all be set out in more detail in the final published volume. Here, each technology will only be briefly described.

Interception

Interception of rain water before it reaches the ground has the advantage that the water may be collected without many contaminants and that the water generally will be suitable for meeting most domestic requirements. The quantity of water that can be harvested will be determined by the amount of rainfall, and the size of the area from which the water is collected. For example, 10 mm of rainfall can provide 100,000 litres of water per hectare.

Some methods of water interception in general use include the use of roofs, courtyards, and ground (surface) catchments.

R o o f s

The use of roofs for water collection is widely practised throughout the tropical world. Corrugated galvanised iron roofs have been used to harvest rain water in many humid and sub-humid regions. These roofs are cheap, and, when used with gutters, can collect water without exorbitant maintenance costs. Such roofs are also durable, except in coastal regions where they tend to rust because of salt action.

Costs may be kept down by the increased use of local materials, such as tiles which can be produced on a self-help basis. Tile roofs are very durable and require little maintenance. Tiles also make less noise during rains than iron sheets, but their weight requires a stronger supporting frame.

In many African countries, thatched roofs are common and can be used to intercept water in small quantities when gutters are installed. The water collected though is coloured and unattractive. Also it is easily contaminated. Thatched roofs are less durable than corrugated iron sheets or tiles. They can be improved by using plastic sheeting which provides a good catchment surface for water harvesting. But, although cheap in cost, such sheeting is not durable. It is easily torn or covered by algal growth and must be replaced at short intervals. Roof catchments made from cement, bituminous paper and sisal-reinforced materials are in use but are not yet common. Under satisfactory climatic conditions, collection of rain water from roofs, when efficiently done, can supplement other water supplies effectively. For example, where the average rainfall is 1,800mm (with an intensity of 0.2mm per minute as in the Gusii Highlands of Kenya), using 5,000 litre storage tanks, enough water can be collected in 12 hours to serve a family of 6 for 45 days. Where there are many rainy days per year (150 in this example) large quantities of water can be collected.

C o u r t y a r d s

Tiled, concreted, bituminized or simply compacted courtyards have been used for harvesting water since Roman times. This technique poses more health hazards than roof harvesting methods because the rain water is allowed to come in contact with the ground. In China where this technique is common the harvested water is kept for long periods in dark, quiet storage tanks. The technique is not generally used in tropical countries.

G r o u n d C a t c h m e n t s

Ground catchments are ideal for collecting storm water (surface run-off) and the amount of water to be collected depends greatly on the amount of rain, size and surface of the catchment. The lowest rainfall limit possible for this sort of harvesting seems to be 50 - 80mm, but even 24mm has been reported to yield a useful amount of water from catchments in the Negev Desert.

In this technique the ground catchment is compacted and the run-off collects in depressions, reservoirs or tanks (Fig. 1A). In Australia, the West Indies and elsewhere, the catchment surface is often coated with

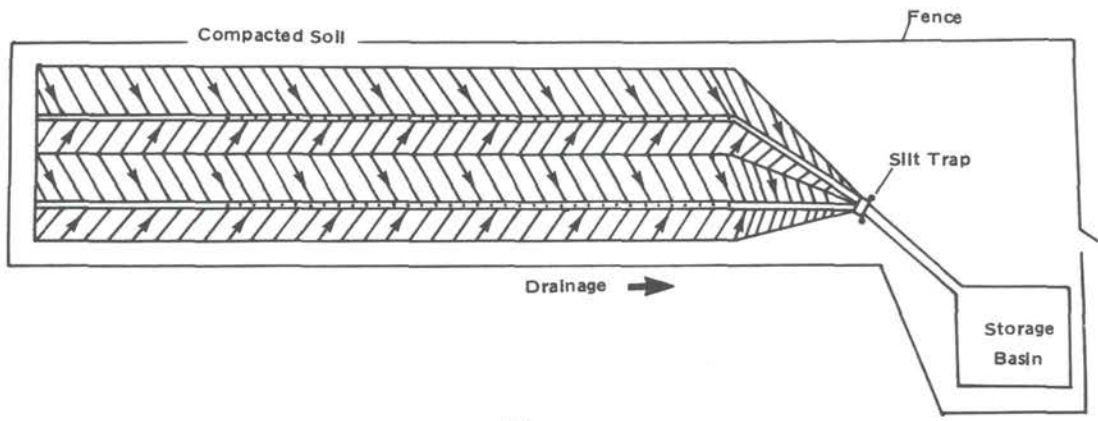

(A)

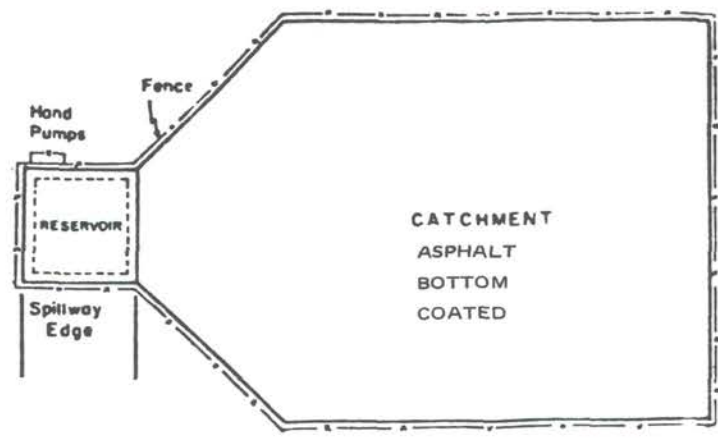

(B)

Fig. 1. Ground catchments with convex surfaces and collecting drains (A), versus flat asphalt surface (B).

asphalt, cement, or other materials to reduce water loss through seepage (Fig. 1B). Natural catchments of exposed rock face have also been used in various parts of the world.

Run-off water collected and stored in this fashion needs proper management, such as fencing or hedging around the catchment to prevent contamination and pollution from animals and birds, and covering, to prevent health hazards.

Separation

The first rain water running off of roofs or courtyards normally contains a lot of sediment. For health reasons and also to keep the water potable, this water should be separated from the supply to be stored.

The simplest device for separating the first flush of rain water is a simple throw-over valve, or even a plastic hose which can be deflected from the storage tank. However, such systems are quite unreliable. Simple automatic systems are available and they are easy to install. An interesting example from Australia (Fig. 2) is particularly well-suited for roof catchments. This device is a swing funnel made out of sheet metal. The first flush of rain water falls into "A" causing an increase in weight because the exit drain is very slow. The funnel falls toward the wall and allows clean water then to flow through "B" into the storage tank. After some time the slow leak from "A" allows the funnel to fall back into the ready position in time for the next rainstorm.

Another device is a simple baffle tank (Fig.3) where the run-off passes through a baffle and a sieve before going over a standpipe. Sediments settle to the bottom of the box which needs periodic cleaning.

Filtration

Water collected especially from ground catchments can be cleaned by using silt traps and sand filters prior to storage. Any number of simple filters have been designed that separate debris and grit from harvested rain water. They generally consist of a container filled with layers of sand and gravel; good examples can be seen at the UNICEF Village Technology Unit in Karen, Kenya. Such filters must be cleaned out or renewed occasionally. More permanent filters can be constructed out of cement and incorporated into house construction, in line with storage tanks or cisterns.

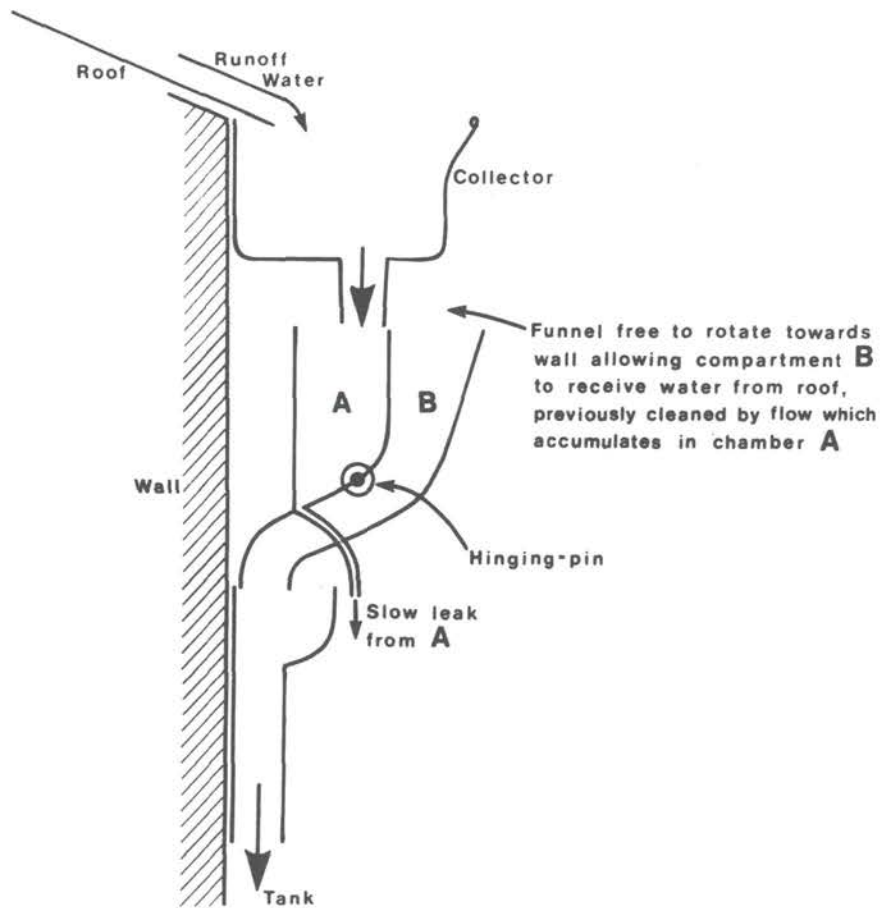

Fig. 2. Swing funnel for separation of first rain water from the later cleaner run-off.

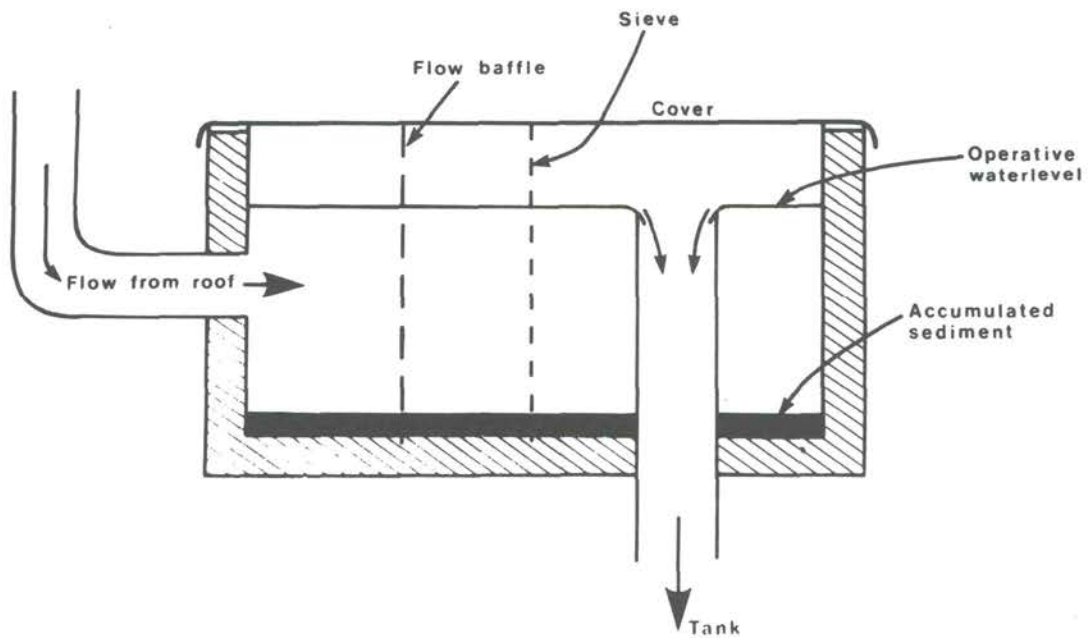

Fig. 3. Baffle tank to allow grit and dirt to settle from the first flush of water off of a roof.

Storage

Storage facilities can be below ground or above ground. Whichever type is used, it is recommended that the container selected be fully covered to prevent contamination due to dust, humans and animals; as well as to prevent algal growth and the breeding of mosquito larvae. Open containers or household ponds are not recommended for reasons of health and loss due to evaporation.

B e l o w - G r o u n d C o n t a i n e r s

Below-ground storage facilities have the advantage of generally being cool. There can also be a saving in space and cost of construction because the container can be moulded directly in the ground by simply compacting the earth, using cement applied by hand, or simple plastic sheeting draped on the walls of an excavation. Although cement is the ideal material to use, in some locations natural rock may be excavated to provide below-ground cisterns.

A good example of a moulded below-ground container where the soil is simply compacted is shown in Fig.4. This is an underground storage well typical in those parts of China where the soil is suitable for use as a moulding medium.

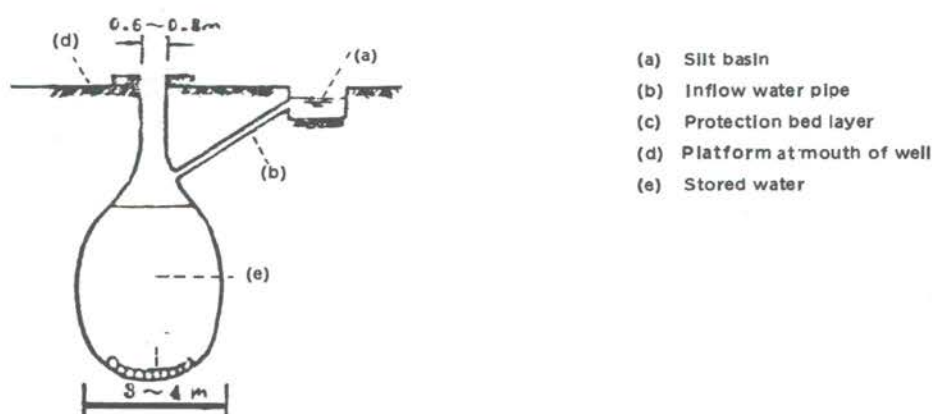

Fig. 4. Underground well for storing rain water collected from courtyard areas in China.

Nowadays, reinforced concrete tanks are easily installed underground by using a double walled steel form. This circular form is lowered into an excavation and concrete is poured into the space between the two walls. The inner and outer steel wall is then removed a day later leaving a large round concrete tank. Reinforcing is usually added prior to pouring the concrete, the bottom floor and top cover are added and the excavation is filled. Such tanks represent a substantial initial investment, but the final product has the advantage of extreme durability and potentially large size. In Australia, the most common size has a volume of 100,000 litres. Because of their strength, they can be used as part of a structural foundation. When set in-line with sand filters and settling tanks and equipped with hand or power pumps they can be used to create completely independent, long-term water storage facilities.

A b o v e - G r o u n d C o n t a i n e r s

Here there is a wide choice between materials depending on the range of socio-economic conditions as well as environmental requirements.

M e t a l T a n k s

The most common material used is galvanised sheet iron which can be readily riveted and soft-soldered. However, unless they are structurally reinforced by either a steel or wooden frame-work, such tanks can suffer considerable deformation when filled, and this limits their maximum capacity to about 1000 litres. Tanks of this type have been widely used since the 19th Century. Such tanks could probably be incorporated as part of the wall structure of many types of houses but, periodic inspection for rust is necessary, and maintenance must be promptly carried out.

C o r r u g a t e d I r o n T a n k s

This type of tank is a very common type of above-ground storage container. Capacities of up to 10,000 litres are found in Africa, and many other regions.

Stone, Brick And Mortar Tanks

Depending on availability, either stone or brick can be used to build walls bonded either by lime-mortar or cement mix. Where large tanks are required and, certainly when their height exceeds two metres, peripheral reinforcing is simply done by tightening a steel band around the outer circumference. The roofing of this type of tank should be suitable impervious sheeting such as galvanized iron supported by a wooden framework.

Clay, Cement And Wooden Containers

In areas where clay is available, as in many parts of Africa, Asia and Latin America, fired clay pots provide an elegant solution to water storage problems. The main disadvantage would appear to be those of limited volume and permeability of the container. Possible developments might include simplified glazing techniques to increase the impermeability of the "pots". However, the cooling effect, because of their porosity is an advantage that should not be overlooked.

There is considerable scope for designing novel clay storage units which may be incorporated into the wall design of domestic buildings. Water storage containers appropriate for such use have been designed by the UNICEF Village Technology Unit. They have developed an interesting version of the clay container. This is the Ghala Tank which is made by moulding cement inside and outside over a large woven granary basket (Fig.5). If the cement wall thickness

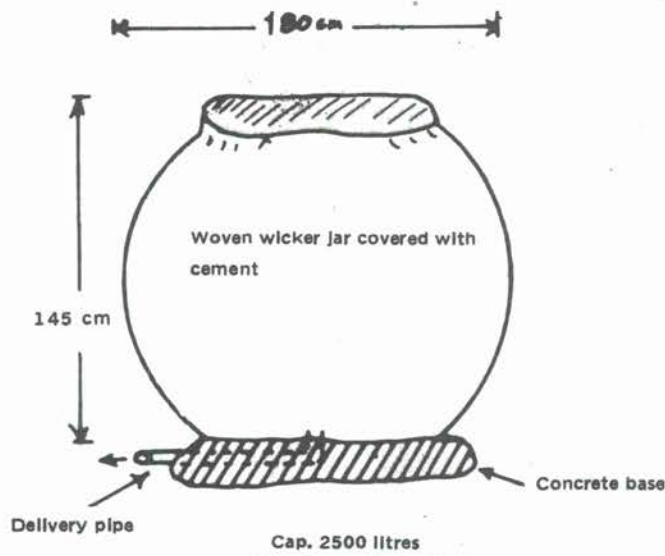

Fig. 5. Ghala Tank made by moulding cement inside and outside of a large woven granary basket.

is 3 cm, large containers up to 2,500 litres capacity can be built. A simple delivery pipe is positioned inside the concrete base during construction.

Wooden barrels are also of use in rain water storage, and were common in Europe, North America and Australia years ago. Their disadvantages (limited volume, susceptibility to rot, etc.) far outweigh their advantages. Consequently they are seldom recommended nowadays.

Water Treatment

Water harvested through adequate catchment provisions and stored under safe conditions often does not require any treatment to be suitable for domestic water supply. A light treatment using a simple device such as pot chlorination may be provided as a safety precaution. When new storage containers made from cement are used for rain water storage, they can be 'cured' by washing with a weak acid (or vinegar) in order to improve the water quality.

The rapid filtration of rainwater before it is stored is effective for removal of grit and debris, but this is seldom effective for removal of bacteria if the water is heavily contaminated. It is always desirable to boil water before consumptive use. This practice may be replaced at some future date by distilling water using simple solar stills, but at present such a technique is not readily available. For small quantities of water, pot filtration in household trickle filters prior to use gives satisfactory results. Such filters (Fig.6)

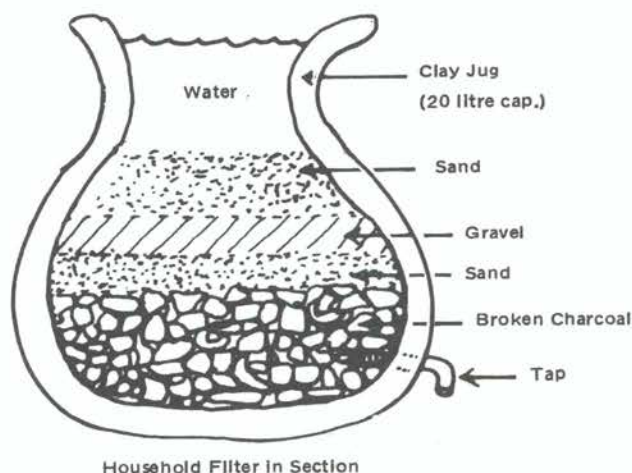

Fig. 6. Pot filter shown in cross section.

can be easily maintained. Larger quantities of water such as that stored in below-ground tanks can be effectively treated in long-term storage by slow sand filtration.

Treatment of small quantities of water can also be done using indigenous plants and natural products. This has been in traditional use in some countries for many years. Certain soils, such as the clay known as "clarifying earth" in Gezira and Northern Province in Sudan, produces floc in turbid water and induces sedimentation. A similar flocculation of suspended solids can be achieved adding certain pounded or crushed plants to the water. This is a common practice in Sudan and the coastal regions in East Africa.

Distribution

Sometimes rainwater is stored in catchment tanks or large basins in uphill areas where it is gravity fed to the point of use. In these cases the bacteriological safety of the water must receive particular attention.

More often, the water has to be lifted from the storage facility. In this regard, rope and bucket, endless chains with discs rotated over a winch axis, and similar devices have all been used and, in most cases, contamination of the water is possible, so that alternate methods should be used. Hand pumps are particularly useful in that they can be permanently installed and have a long service life under the low use conditions.

The use of harvested rain water by ordinary rural households would not require any elaborate distribution scheme. But in community-operated catchment projects for domestic water supply, the water can be taken out through a pipe embedded in the embankment, subjected to suitable treatment (e.g. slow sand filtration) and conveyed to the village in a pipe or covered channel. The system can work by gravity, if the embankment is built on ground higher than the village. Alternatively, if individual houses have their own underground storage tanks built to store rain water harvested from rooftops, they can simply be replenished seasonally.

RAIN AND STORM WATER HARVESTING FOR
AGRICULTURAL USE

Generally run-off after heavier rains collects in rivers and other depressions, but this run-off may also be deliberately harvested for use in agriculture. The technologies used in this type of agriculture have remained virtually unchanged for thousands of years. Essentially the techniques are geared to successively slow down the passage of silt-laden run-off so as to make both silt and water more effectively available for crop plants.

Contour Terrace Farming

Contour farming consists of placing long, low barriers perpendicular to the gradients, along contour lines which intercept and retain run-off and silt. The barriers can be of stone, logs, earth or hedge. In Mexico, for example, the barrier is often a sisal-like plant "maguey", which is simply planted on top of a soil barrier, and this may also be strengthened by stone (Fig. 7). Immediately below the barrier a trench can be dug which acts as

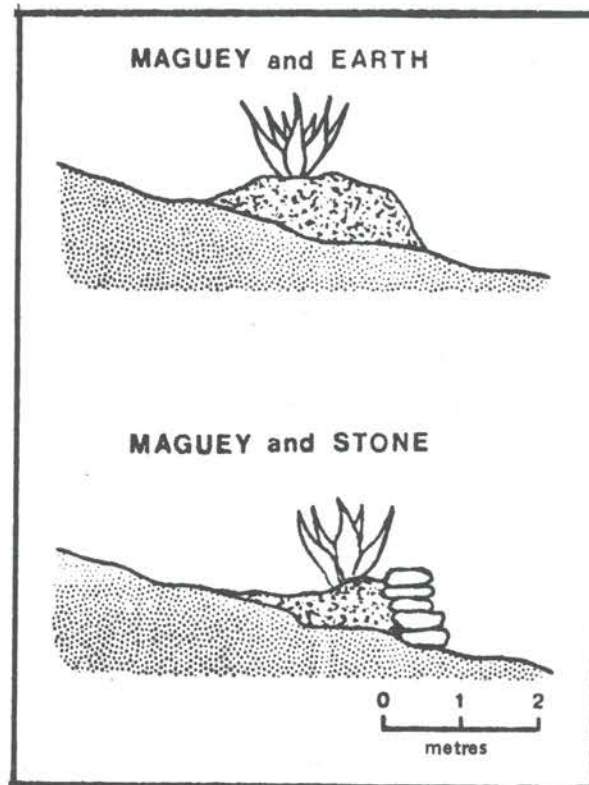

Fig. 7. Soil barrier built up out of soil, plants and stone. The plant used is "maguey" which is an agave plant.

a drain. This in turn can be connected at right angles by cross drains, depending on the amount of drainage required on a particular plot (Fig. 8). Unlike conventional forms of terracing, this technique leaves the natural groundslope only marginally altered.

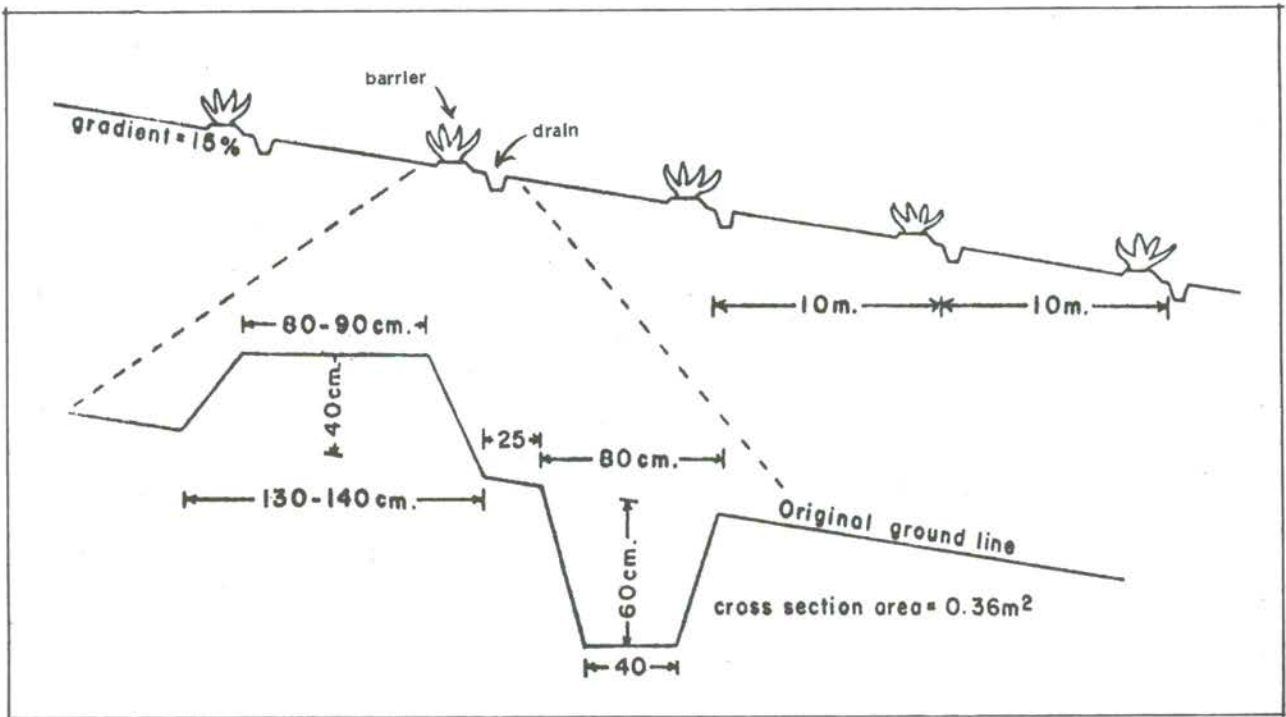

Fig. 8. Cross section of a contour terrace showing barriers and drains.

Contour agriculture lends itself to the use of local labour and is suitable for adoption where the mean annual rainfall is 400 mm or more. In such areas it will definitely help to prevent soil erosion.

In areas where rainfall exceeds 500 mm (esp. if 1000+ mm) a water harvesting terrace technique has been developed to allow for the conservation of excess water. This has proven to be especially useful in southern Tanzania and in Zambia. Here ditches are dug following contours and the soil is piled up on the downhill side, creating wide shallow furrows which are

so carefully levelled that they will retain excess run-off during the rainy season. This excess slowly seeps into the soil. Seepage in this case is in fact encouraged in clay pan areas by actually drilling with a soil auger and filling the holes with sand or gravel. With the careful use of spillways to control water levels, this system of furrows can be built up to completely control sheet flow during average rainfall years.

Silt Traps

Silt traps are built of stone, earth or rockfill across the bed of intermittent streams, often in narrow valleys, gorges or gullies. They are designed to trap rainstorm run-off and sediments for farming flat land in gullies. Over the years the alluvial deposits build up, and level fields are created behind the dams (Fig. 9). This practice has conclusively shown in Mexico and China that silt traps are very useful structures for rain water harvesting and storage.

In designing silt traps it is necessary to ensure that the right topographic conditions are present. It is preferable to construct silt traps in series, because such series are always safer than single traps. Within the series there should be some traps with larger capacities to absorb unusual floods. But in any event the larger traps should have spillways to ensure their safety. The height of a silt trap is determined by the flood discharge and maximum volume of silt expected during the flood. Therefore, the design height should equal the thickness of siltation expected, plus the depth of flood detention, plus freeboard. In China a 10% flood is used as a design figure for silt traps having a height of less than 10 metres.

The cross section of a silt trap is dependant on dam height, soil properties, construction methods and traffic requirements. For larger traps it is often necessary to construct conduits to either release clear water for irrigation or to release muddy water to provide silt as a growth medium for crops in adjacent fields. This technique is known as "warping" in China where it is extensively practised.

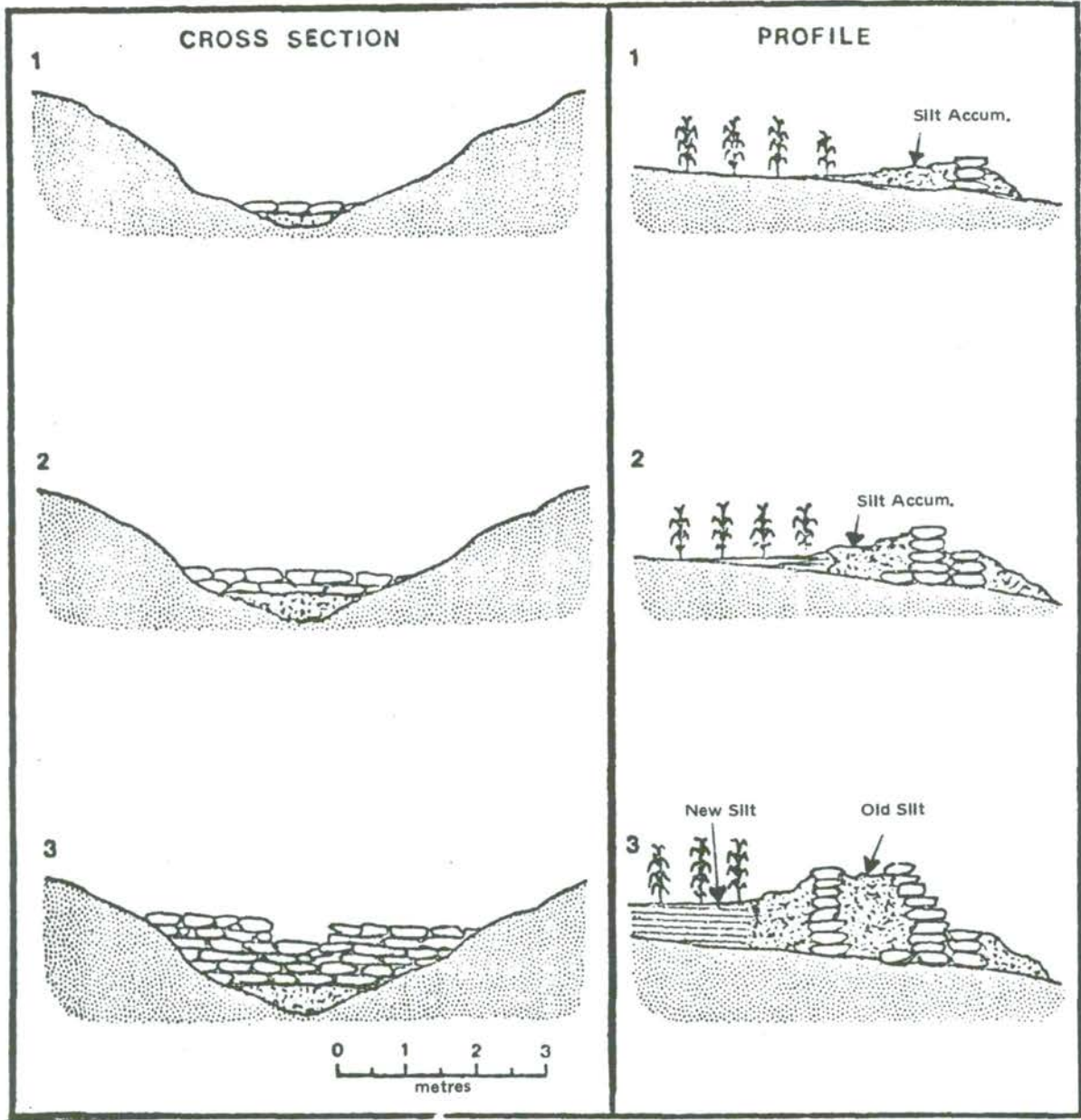

Fig.9. Filling-in of silt traps over a period of years.

Check Dams and Haffirs

Check dams are small dams which impound storm run-off. They are a common feature of rural landscapes in many parts of the world. Check dams are built across gullies in China, India, Central America and elsewhere. Haffirs, on the other hand, are excavations made at the bottom of natural catchments and are common in the Middle East, North Africa and western India. The water harvested by check dams and haffirs is generally used for livestock and irrigation, but if properly treated it can sometimes be used for human consumption.

Check dams may be relatively simple structures causing very little alteration of local topography. They may also involve considerable alteration or preparation of the catchment prior to water harvesting. Check dams of the first type are characteristically located at favourable sites, such as across water courses in narrow valleys with impervious rock or soil strata. These have the advantage of low cost, but the number of favourable sites available is usually limited. Where feasible, such check dams should be given priority choice.

The second type of check dam is more sophisticated and involves a greater input of labour and capital. The catchment and impoundment area are usually considerably altered in this type of check dam through land alteration. This would include compaction of earth on the catchment, removal of stones and vegetation on the catchment to increase run-off and planting grass cover to increase run-off but decrease soil erosion. In some areas the catchments are chemically or physically treated to increase run-off and decrease seepage.

Check dams are an effective means of harvesting and storing storm run-off from large catchments, even under arid conditions. They are a valuable source of supplementary water supply and can be designed and constructed using local materials and labour, even by small communities. However, in some areas, they may enhance water-related diseases if not controlled. If high losses due to evaporation do not occur and maintenance is kept up, check dams are excellent for water conservation.

Haffirs have been particularly successful in southern Sudan. For example, in the vast southern plains area the soils are poorly drained with only a slight gradient. This results in an overland flooding during the rains with a "creeping flow" of water across the region. Haffirs are therefore built by digging out a low area and the excavated soil is heaped up on the downslope to form a large bund. Water flows into the haffir from the creeping flow and provides a dry season supply for the local cattle. As a result of haffirs, herdsmen tend to stay near their villages rather than to seasonally migrate and they are also in a better position to plant staple food crops prior to the early rains.

Normally, the haffir water is used mainly for livestock where boreholes are provided by the government for potable water. In areas where there are no boreholes, instead of local people taking water from the haffir, it may be profitable to provide one section of the haffir with a sand-filled water storage tank and a well from which potable water can be drawn.

Flood Water Farming

Flood water farming consists of a series of strategies to harvest storm run-off by planting crops in areas likely to be flooded, either by channelled or sheet run-off. This is a risky form of water harvesting as crops fail in dry years and can be washed away in years of excessive rainfall. Nevertheless, it remains an important strategy in some areas where other forms of agriculture are impractical and could certainly be improved for wider application.

Site selection is the key to success in flood water farming. Three principal types of sites are preferred: (a) slopes below escarpments; (b) alluvial deltas; and (c) floodplains

After site selection, the area can be prepared by digging flood canals or dykes in order to spread out the flood. A good example from Pakistan is shown in Fig. 10 where water spreading dykes are constructed in a zig-zag pattern to slow the torrent of flood water and allow it to penetrate the soil. Crops are then planted in the wet areas behind the dykes.

Canalization is also a common type of floodwater harvesting in small agricultural schemes. The inundation canals of Egypt and the 'ahars' of India are good examples, but they also provide a good habitat for disease vectors.

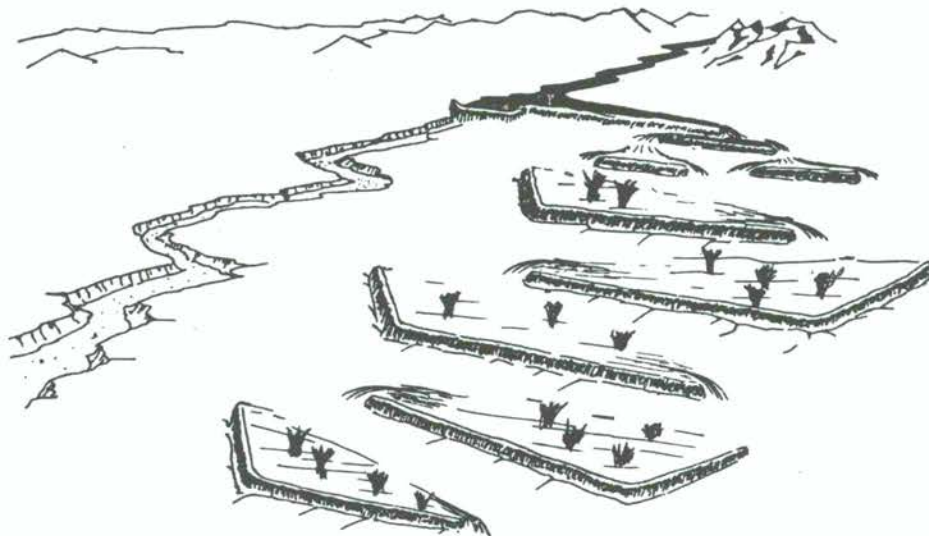

Fig. 10. Water spreading dykes constructed in series to slow floodwater and harvest the water by seepage.

Because of its site specificity, unreliability and questions arising from its possible environmental impacts, floodwater farming should be practised with extreme care.

Certain practices of water spreading on alluvial deltas and floodplains do deserve further consideration and study. For example, there is the Chinese practice of canalizing silt-laden flood waters and spreading both the water and the silt on flat areas for crop growth. This "warping", can be so effective that it becomes part of the traditional pattern of farm life in a rural area. But, as has been pointed out, generally, floodwater farming is often unreliable unless it is carried out as part of an integrated development scheme.

Microcatchment Farming

On barren loess desert plains, experimental studies have shown that it is possible to grow pasture shrubs where annual rainfall is of the order of 100mm. The technique consists of building low earthen border walls (about 15-20cm high) enclosing a plot of 16 to 1000 square metres on sloping land. A shrub or tree seedling is then planted at the lowest point on the plot. Rainfall over the microcatchment collects near the plant at the lowest point on the plot

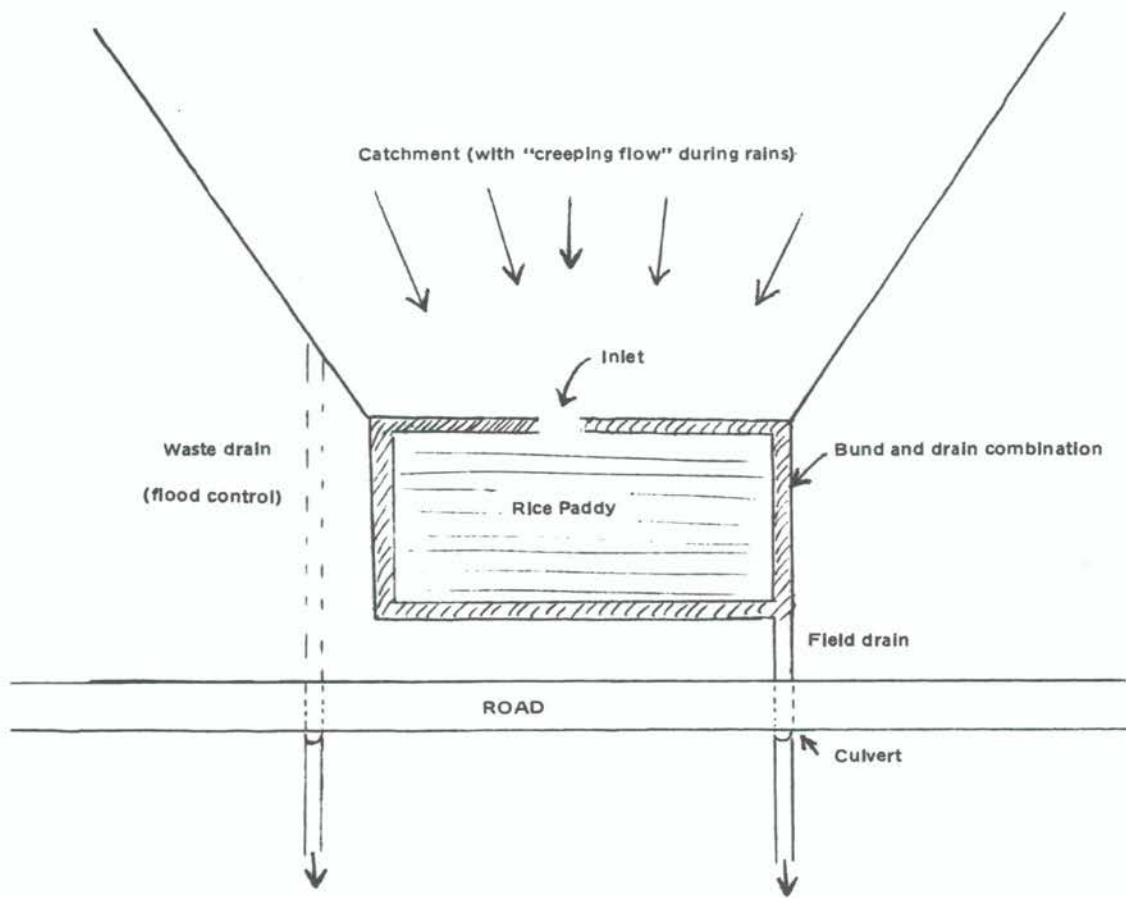

(A)

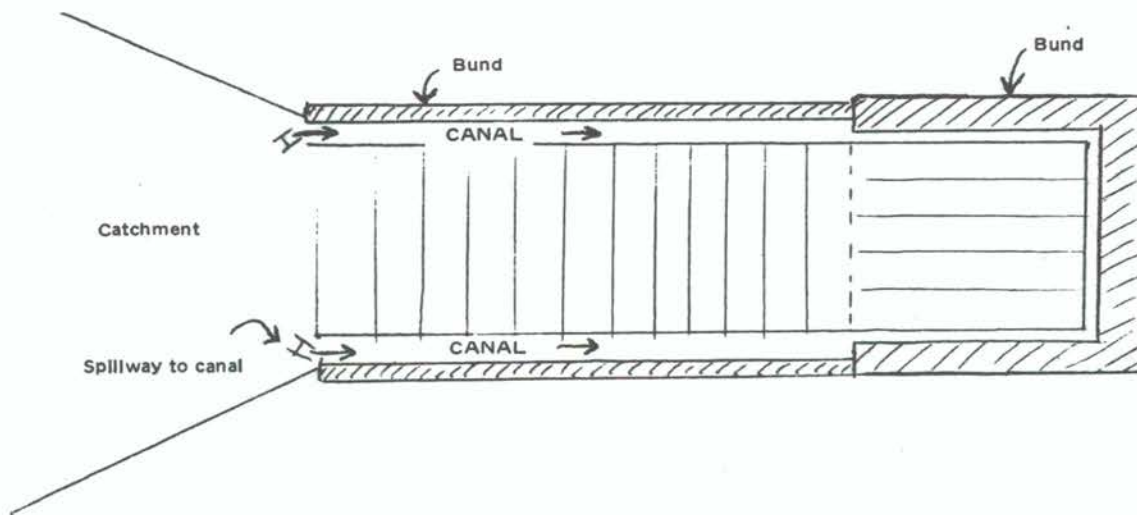

(B)

Fig. 11. Haffirs arranged to provide water for rice paddy (A) and ranching scheme using paddocks (B).

and is absorbed by the soil so that the seepage water is close to the plant roots. The root-zone soil on such plots must be at least $1\frac{1}{2}$ metres deep.

There are other variations on microcatchment farming. For example, in the southern Sudan, where there are extensive regions with poor drainage and where the land is subject to creeping flows of water during the rains, it is possible that fast-growing rice varieties could be cultivated in paddies filled by harvesting the creeping flow (Fig. 11A). Also microcatchment farming should be tried in connection with grazing paddocks (Fig. 11B) in order to use run-off to cultivate all-weather grazing for local herds. Such systems when used in connection with water storage in haffirs seem to hold much promise for integrated development. They have the potential for providing water for nomadic tribes in areas where farming and cattle raising can be successfully demonstrated on a year-round basis.

WATER FROM MIST, DEW AND SNOW

It is perhaps because most people in well-watered and hospitable climates are used to having water available in terms of tens of litres at a time rather than a few cupfuls, that they do not appreciate how welcome the reliable provision of even half a litre of water a day can be to an inhabitant of a dry area. In arid and semi-arid areas, where rivers and lakes are few and far between, much experimentation has been done on the collection of fog and dew to supplement water supply. A very promising technique is the use of wire or plastic mesh for collecting water from fog and mist. Under the ideal foggy conditions on mountains in Tasmania, from mist with a water content of one gram per cubic metre, and a wind speed of 13 km per second, a yield of 47 litres per hour is believed to be possible. The mesh used is similar to ordinary mosquito mesh which is a cheap and readily available material throughout the tropics.

It is possible to construct simple dew collectors out of wooden planks arranged into a rough funnel or piles of rocks supported about one metre above the ground. Dew settling on one square metre of such a surface can give up to 0.4 litres of water in a night. In an arid region such water would be quite valuable.

Vegetation often acts as a natural dew collector in countries such as Japan. In Kenya, dew intercepted by trees is collected by means of a rope coiled around the trunk with the free, lower end of the rope resting in a bucket.

In the colder regions of the world, such as, Afghanistan, snow is collected and kept covered below ground in containers near villages. As the snow melts the water trickles out through a small bamboo pipe. One such pit is said to have supplied drinking water for a village of 10 families for 2 years.

Under certain favourable circumstances it is possible to harvest dew for agricultural purposes. One example from China illustrates an ingenious technique.

In Gansu Province, north-west China, there is poor annual precipitation, frequent wind, drought and a high rate of evaporation. The people here have had a long history of agricultural production and, with time, have developed a unique method of cultivation by means of which they grow delicious melons which are famous through the area. The melons are cultivated in a soil bed which is covered with a layer of gravel, 10 - 15 cm thick. The pieces of gravel range from 2 to 5 cm diam., and in Chinese these farms are known as "gravel fields for melon".

This cultivation method depends on the following factors: First, the gravel layer maintains soil moisture, sharply minimizing evaporation losses; second, the gravel absorbs the sun's energy, thus raising soil temperature; third, in the evening, the gravel layer becomes cold, from the gravel layer and the soil water condenses forming drops on the surface of the gravel, and this moistens the soil, providing a satisfactory growing medium for the melons.

In summary, it is recommended that these dew and mist harvesting techniques may also be attempted in areas such as warm arid regions where conditions are suitable for dew formation, and also in mountain areas where mist is present.

In conclusion it needs to be emphasised that this document represents only an initial attempt to bring together information on technologies for rain and storm water harvesting which exists all over the world.

References, bibliography and acknowledgements can be found in the forthcoming Final Report. For further information contact the Regional Office for Africa, United Nations Environment Programme, Nairobi.

RAIN AND STORM WATER HARVESTING

Experts Group Meeting

Participants

FP/1107-77-04

Nairobi, 1979

UNITED NATIONS:

- | | |
|-----------------------|--|
| Dr. Letitia E. Obeng | - UNEP, P. O. Box 30552, Nairobi.
Chairman, Soil and Water Task Force |
| Dr. N. Gebremedhin | - UNEP, Human Settlement Task Force
P. O. Box 30552, Nairobi. |
| Ms. Enid Burke | - UNEP Information Division
P. O. Box 30552, Nairobi |
| Ms. Abeba Wolderufael | - UNICEF, Village Technology Unit
P. O. Box 44145, Nairobi |

CONSULTANTS:

- | | |
|-------------------------|---|
| Dr. Kirsten Johnson | - Department of Geography,
Clark University,
Worcester,
Mass., 0610,
U.S.A. |
| Dr. Liang Jian | - Environment Protection Office of
Ministry of Water and Conservancy
and Electric Power,
The People's Republic of China. |
| Dr. Peter Schwerdtfeger | - Professor of Meteorology,
Flinders University of South Australia,
Adelaide,
Australia, 5042. |
| Prof. Rama Prasad | - Department of Civil Engineering,
Indian Institute of Science,
Bangalore 560 012,
India. |

Dr. George Ongweny

- Department of Geography,
University of Nairobi,
P. O. Box 30197,
Nairobi.

Dr. Georgy Kovacs

- National Water Authority,
1394 Budapest,
II. F.O. - UTCA 48-50 Hungary.

ASSESSORS:

Dr. John J. Gaudet

- University of Nairobi,
P. O. Box 30197,
Nairobi.

Dr. Ebbo H. Hofkes

- WHO International Reference Centre
for Community Water Supply,
P. O. Box 140, Leidschendam,
(The Hague),
Netherlands.

Dr. Gerd-Jan de Kruijff

- University of Nairobi,
Housing Research and Development,
P. O. Box 30197,
Nairobi.

