



Programme des Nations Unies pour l'environnement

Distr.
RESTREINTE
UNEP/IG.23/INF.5
15 décembre 1980
FRANCAIS/ANGLAIS
Original : FRANCAIS/ANGLAIS

Deuxième Réunion des Parties Contractantes
à la Convention pour la protection de la mer
Méditerranée contre la pollution et aux
protocoles y relatifs et Réunion Inter-
gouvernementale des Etats côtiers de la
Méditerranée chargée d'évaluer l'état
d'avancement du Plan d'action

Cannes, 2-7 mars 1981

TESTS CONVENUS PAR LA COMMISSION DE LA CONVENTION D'OSLO

Note du Directeur exécutif

Les experts chargés d'examiner le Protocole relatif à la prévention de la pollution de la mer Méditerranée par les opérations d'immersion effectuées par les navires et aéronefs, réunis à Genève du 2 au 6 juillet 1979, avaient noté les difficultés que comportait l'interprétation sans ambiguïtés de certains termes ou expressions figurant dans les annexes dudit protocole. Ils avaient insisté sur la nécessité de baser leur définition sur des données scientifiques, notamment sur des tests de toxicité, de bio-accumulation et de dégradation, et avaient en conséquence recommandé au secrétariat du PNUÉ de distribuer aux Parties Contractantes les tests convenus par la Commission de la Convention d'Oslo (UNEP/WG.28/3, para 22-23).

Les tests de la Commission de la Convention d'Oslo sont joints à cette note dans les langues originales. Ils devront servir aux experts techniques qui seront chargés de définir les expressions employées dans les annexes du protocole et les méthodes d'essai à utiliser.

La Commission de la Convention d'Oslo a décidé de revoir ces tests et a créé à cet effet un Groupe de travail qui devrait se réunir dans le courant de l'année 1981 et faire rapport à la 8ème Réunion de la Commission.

TESTS RECOMMENDED BY THE COMMISSION OF THE OSLO CONVENTION

Note by the Executive Director

At the meeting held in Geneva from 2 to 7 July 1979, the experts while considering the protocol for the prevention of pollution of the Mediterranean Sea by dumping

from ships and aircraft, noted the difficulties involved in interpreting without ambiguity certain terms and expressions contained in the annexes to the protocol. They stressed the need to define them on the basis of scientific data, including, in particular, tests of toxicity, bio-accumulation and degradation, and consequently requested the UNEP secretariat to distribute to the Contracting Parties the tests recommended by the Commission of the Oslo Convention (UNEP/WG.28/3, para 22-23).

The tests of the Commission of the Oslo Convention are attached to this note in the original languages. They should be used by the technical experts who will be assigned the tasks of defining the expressions used in the annexes to the protocol and of specifying the test methods to be utilized.

The Commission of the Oslo Convention has decided to embark on a review of these tests and has established a working group for that purpose which should meet during 1981 and report to the eighth meeting of the Commission.

TABLE DES MATIERES

TABLE OF CONTENT

	<u>Langues</u> <u>Languages</u>	<u>Pages</u>
1. Calculs des besoins chimiques en oxygène Measurement of Chemical oxygen demand. (Irlande/Ireland).	Anglais/Français English/French	1 - 7
2. Méthodes employées dans certains laboratoires suédois pour l'estimation des effets aigus et sub-letaux, et de l'accumulation des substances toxiques chez les animaux aquatiques ⁴ Methods used at some swedish laboratories for testing acute effects, sublethal effects and accumulation of toxic substances in aquatic animals.	Anglais/Français English/French	8 - 21
3. a) Determination of the degradability of organic compounds b) The Die-Away test of substrate in shake flasks. (Centraal Laboratorium TNO, Delft).	Anglais seulement English only	22 - 32
4. Méthodologie des expériences relatives à la procédure de consultation préalable. Test procedures under the "Prior consultation procedures".	Anglais/Français English/French	33 - 97
5. Chronic toxicity testing with ARTEMIA SALINA (Linnaeus, 1758) - Crustacea, Anostraca, the brine shrimp. (Centraal Laboratorium TNO, Delft).	Anglais seulement English only	98 - 121
6. Method for measurment of accumulation and elimination. (Centraal Laboratorium TNO, Delft).	Anglais seulement English only	122 - 137

	<u>Langues</u>	<u>Pages</u>
	<u>Languages</u>	
7. Test procedures - comments of the Federal Republic of Germany on test procedures under the "Prior Consultation Procedure".	English only Anglais seulement	138 - 183

Measurement of Chemical Oxygen Demand (C.O.D.)

INTRODUCTION

The following procedure for measurement of C.O.D. has been condensed from the American Public Health Association 'Standard Methods for the Examination of Water and Wastewater' which is available from the A.P.H.A. Publication office, 1015 Eighteenth Street, NW, Washington, D.C. 20036, U.S.A. For more complete details of this test reference should be made to the original text and to the bibliography appended thereto.

PRINCIPLE

The C.O.D. determination provides a measure of the oxygen equivalent of that portion of the organic matter in a sample that is susceptible to oxidation by a strong chemical oxidant. The dichromate reflux method has the advantage over other oxidants in oxidizability, applicability to a wide variety of samples, and ease of manipulation. A sample is refluxed with known amounts of potassium dichromate and sulphuric acid, and the excess dichromate is titrated with ferrous ammonium sulphate. The amount of oxidizable organic matters, measured as oxygen equivalent, is proportional to the potassium dichromate consumed. The method outlined below is for a 20 ml sample; the original text details modifications for alternative sample sizes.

INTERFERENCE AND INADEQUACIES

Straight-chain aliphatic compounds, aromatic hydrocarbons, and pyridine are not oxidized to any appreciable extent, although this method gives more nearly complete oxidation than the permanganate method. The straight-chain compounds are more effectively oxidized when silver sulphate is added as a catalyst; however, silver sulfate reacts with chlorides, bromides or iodides to produce precipitates which are only partially oxidized by the procedure. There is no advantage in using

the catalyst in the oxidation of aromatic hydrocarbons, but it is essential to the oxidation of straight-chain alcohols and acids.

The oxidation and other difficulties caused by the presence of chlorides in the sample may be overcome by employing the following method, which is a complexing technic for the elimination of chlorides from the reaction. This is accomplished by adding mercuric sulfate to the samples before refluxing. This ties up the chloride ion as a soluble mercuric chloride complex, which greatly reduces its ability to react further.

APPLICATION

The method can be used to determine C.O.D. values of 50 Mg/l or more with the concentrated dichromate. With the dilute dichromate, values below 10 mg/l are less accurate but may be used to indicate an order of magnitude.

SAMPLING AND STORAGE

Unstable samples should be tested without delay, and samples containing settleable solids should be homogenized sufficiently by means of a blender to permit representative sampling. If there is to be a delay before analysis, the sample may be preserved by acidification with sulfuric acid. Initial dilutions in volumetric flasks should be made on wastes containing a high C.O.D. value in order to reduce the error which is inherent in measuring small sample volumes.

APPARATUS

Reflux apparatus with 250 ml erlenmeyer flasks and ground-glass joints. Hot-plate to produce at least 9 watts/sq.in. of heating surface.

REAGENTS

- a Standard potassium dichromate solution, 0.250 N. Dissolve 12.259 g $K_2Cr_2O_7$, primary standard grade, previously dried at $103^{\circ}C$ for 2 hours, in distilled water and dilute to 1,000 ml.

Note Refer to original text for discussion of procedure to remove interfering nitrite N by use of sulphamic acid (120 mg sulphamic acid per liter of dichromate solution will eliminate the interference of up to 6 mg/l nitrite N in the sample if a 20-ml sample is used.)

- b Sulphuric acid reagent.

Conc. H_2SO_4 containing 22g silver sulphate, (reagent powder) Ag_2SO_4 per 9-lb (4.1 Kg) bottle. (1 to 2 days required for dissolution)

- c Standard ferrous ammonium sulphate titrant, analytical-grade crystals, 0.10 N.

Dissolve 39 g $Fe(NH_4)_2(SO_4)_2 \cdot 6H_2O$ in distilled water. Add 20 ml conc. H_2SO_4 , cool, and dilute to 1 liter. This solution must be standardized against the standard potassium dichromate solution daily.

To standardize: Dilute 10 mls of solution (a) to about 100 ml. Add 30 ml conc. H_2SO_4 and allow to cool. Titrate with solution (c) using 2 or 3 drops of (0.10 - 0.15 ml) ferroin indicator.

$$\text{Normality} = \frac{\text{ml } K_2Cr_2O_7 \times 0.25}{\text{ml } Fe(NH_4)_2(SO_4)_2}$$

- d Ferroin indicator solution

Dissolve 1.735 g 1, 10-phenanthroline dihydrate, together with 695 mg $FeSO_4 \cdot 7H_2O$ in water and dilute to 100 ml

- e Mercuric sulphate, analytical grade crystals.

PROCEDURE

- 1 To a reflux flask add

0.4 $HgSO_4$ (to complex up to 40 mg chloride ion)

20 ml sample (if necessary diluted to 20 ml)

10 ml solution a

Pumice granules or glass beads.

Connect flask to condensor and slowly add 30 ml solution b while mixing thoroughly by a swirling action.

2. Reflux the mixture for 2 hours. Cool and wash down condensor with distilled water.
3. Dilute the mixture to about 150 ml with distilled water, cool, and titrate the excess dichromate with solution c using a consistent quality of ferroin indicator (2 - 3 drops).
4. Reflux in the same manner a blank consisting of 20 ml distilled water together with the other reagents.

Calculation

$$\text{Mg/l C.O.D.} = \frac{(a - b)N \times 8,000}{\text{ml sample}}$$

Where a = ml of solution c used for blank
b = ml of solution c used for sample
c = normality of solution c.

Calculs des Besoins Chimiques en Oxygène
(Chemical Oxygen Demand - C.O.D.)

INTRODUCTION

La relation suivante du test C.O.D. est un précis du document "Standard Methods for the Examination of Water and Wastewater" (Méthodes Normales d'Examen des Eaux et Eaux Résiduelles) que l'on peut se procurer auprès de l'A.P.H.A. Publication Office, 1015 Eighteen Street NW, Washington D.C. 20036, E.-U. Si le lecteur veut des détails plus complets, qu'il veuille bien se reporter au texte original et à la bibliographie qui s'y rattache.

PRINCIPE

Le calcul COD donne une mesure de l'oxygène qui équivaut à cette partie de la matière organique de l'échantillon susceptible d'être oxydée par un oxydant chimique fort. La méthode de reflux au bichromate est supérieure à d'autres oxydants, du point de vue oxydabilité, application à une large gamme d'échantillons et facilité de manipulation. On refluxe un échantillon au moyen de quantités connues de bichromate de potassium et d'acide sulfurique, et le bichromate en excédent est titré au sulfate d'ammonium ferreux. La quantité de substances organiques oxydables mesurée en équivalent d'oxygène est proportionnelle au bichromate de potassium utilisé. La méthode décrite ci-après s'applique à un échantillon de 20 ml ; le texte original donne les détails des modifications à effectuer pour des échantillons de volumes différents.

INTERFERENCES ET DEFAUTS

Les composés aliphatiques à chaîne droite, les hydrocarbures aromatiques et la pyridine ne s'oxydent pas de manière sensible, bien que cette méthode permet d'obtenir une oxydation plus complète que par celle du permanganate. Les composés à chaîne droite s'oxydent mieux quand on y ajoute du sulfate d'argent comme catalyseur. Mais le sulfate d'argent réagit avec les chlorures, bromures et iodures pour former des précipités qui ne sont oxydés que partiellement par la méthode. Le fait d'utiliser un catalyseur ne présente aucun avantage dans l'oxydation des alcools et acides à chaîne droite.

L'oxydation et autres problèmes provoqués par la présence de chlorures dans l'échantillon peuvent être résolus en utilisant la méthode suivante, technique qui produit un complexe destiné à éliminer les chlorures de la réaction. On obtient ceci en ajoutant du sulfate mercurique (bisulfate de mercure) aux échantillons avant le reflux. Ceci lie l'ion de chlorure pour donner un complexe de bichlorure de mercure soluble, ce qui diminue considérablement toute possibilité de réactions supplémentaires.

CHAMP D'APPLICATION

On peut utiliser la méthode pour calculer les valeurs COD de 50 Mg/l ou plus au moyen du bichromate concentré. Si le bichromate est dilué, les valeurs inférieures à 10 mg/l deviennent moins précises, mais peuvent néanmoins servir pour donner un ordre de grandeur.

PRISE D'ECHANTILLON ET STOCKAGE

Les échantillons instables doivent être testés sans retard, et ceux qui contiennent des matières solides décantables doivent être suffisamment homogénéisés au moyen d'un mixeur pour donner un échantillonnage représentatif. Si un retard doit se produire avant l'analyse, il est possible de conserver l'échantillon en l'acidifiant à l'acide sulfurique. Les dilutions initiales en bocal volumétriques doivent être effectuées sur des eaux résiduelles à haute valeur COD afin de minimiser les erreurs relatives à la mesure d'échantillons de faible volume.

APPAREIL

Appareil de reflux, fioles Erlenmeyers de 250 ml avec raccords de verre rodé. Plaque chauffante donnant une surface chauffante d'au moins 9 watts/50mm².

REACTIFS

- a) Solution standard de bichromate de potassium, 0,250 N. Dissoudre 12,259 g. de $K_2Cr_2O_7$, qualité primaire standard, et séchée auparavant à 103°C. pendant 2 heures, dans de l'eau distillée et diluer jusqu'à 1 litre.
N.B. Se reporter au texte original pour la méthode qui consiste à éliminer le nitrite N interférant au moyen d'acide sulfamique (à raison de 120 mg. d'acide sulfamique par litre de solution de bichromate, ceci éliminera l'interférence jusqu'à concurrence de 6 mg/l de nitrite N dans l'échantillon si l'échantillon est de 20 ml.)
- b) Réactif à l'acide sulfurique
 H_2SO_4 concentré contenant 22g. de sulfate d'argent (réactif en poudre) Ag_2SO_4 par flacon de 4,1 kg. (Il faut 1 à 2 jours pour dissoudre le tout).
- c) Sulfate d'ammonium ferreux standard (titrant), cristaux qualité analytique, 0,10 N. Dissoudre 39 g. de $Fe(NH_4)_2(SO_4)_2 \cdot 6H_2O$ dans de l'eau distillée. Ajouter 20 ml de H_2SO_4 concentré et laisser refroidir. Cette solution doit être standardisée tous les jours au moyen de la solution standard de bichromate de potassium.
Pour standardiser : diluer 10ml. de la solution (a) jusqu'à environ 100ml. Ajouter 30 ml. de H_2SO_4 concentré et laisser refroidir. Titrer avec la solution (c) au moyen de 2 ou 3 gouttes de (0,10 - 0,15 ml) d'indicateur "ferroin"

$$ml K_2Cr_2O_7 \times 0,25$$

Normalité :

$$ml Fe(NH_4)_2(SO_4)_2$$

- d) Solution d'indicateur "ferroin"
Dissoudre 1,735 g. l, 10-phenanthroline dihydrate , avec
695 mg de $Fe SO_4 \cdot 7H_2O$ dans de l'eau, et diluer jusqu'à
100 ml.
- e) Bisulfate de mercure, cristaux qualité analytique.

METHODE

1. Ajouter à un ballon à reflux :
0,4 $HgSO_4$ (afin de complexer jusqu'à 40 mg ion de
chlorure)
20 ml d'échantillon (si nécessaire dilué à 20 ml)
10 ml de la solution a)
Billes de verre ou poudre de pierre ponce.
Relier le ballon au condenseur et ajouter lentement 30 ml. de
la solution b) tout en tournant pour bien mélanger.
2. Refluxer le mélange pendant 2 heures. Laisser refroidir et
rincer le condenseur à l'eau distillée.
3. Diluer le mélange pour obtenir 150 ml. au moyen d'eau dis-
tillée, laisser refroidir et titrer le bichromate en excé-
dent avec la solution c) en utilisant un indicateur "ferroin"
de qualité uniforme (2 à 3 gouttes).
4. Refluxer à la même manière un ballon à blanc rempli de 20 ml
d'eau distillée additionné des autres réactifs.

Calculs

$$\begin{aligned} \text{Mg/l COD} &= \frac{(a - b)N \times 8.000}{\text{d'échantillon}} \\ \text{Quand a} &= \text{ml de solution c utilisée pour le} \\ &\quad \text{ballon à blanc} \\ \text{Quand b} &= \text{ml de solution c utilisée pour} \\ &\quad \text{l'échantillon} \\ \text{Quand c} &= \text{normalité de la solution c.} \end{aligned}$$

CONVENTION FOR THE PREVENTION OF MARINE POLLUTION BY DUMPING FROM
SHIPS AND AIRCRAFT

FOURTH MEETING OF THE STANDING ADVISORY COMMITTEE FOR SCIENTIFIC
ADVICE

NANTES 8-10 SEPTEMBER 1976

METHODS USED AT SOME SWEDISH LABORATORIES FOR TESTING ACUTE EFFECTS,
SUBLETHAL EFFECTS AND ACCUMULATION OF TOXIC SUBSTANCES IN AQUATIC
ANIMALS

METHODS USED AT SOME SWEDISH LABORATORIES FOR TESTING ACUTE EFFECTS, SUB-
LETHAL EFFECTS AND ACCUMULATION OF TOXIC SUBSTANCES IN AQUATIC ANIMALS

ACUTE EFFECTS I

PARAMETER STUDIED: Mortality expressed both as median survival time and 96-h LC50.

Criteria for death: Cessation of breathing and body movements (fish and crustaceans). Complete inactivation of the adductor muscles and the mantle edge muscles (bivalves).

TEST ANIMALS: Fish, crustaceans and bivalves. They represent different biological types and modes of life.

EXPERIMENTAL
CONDITIONS:

The testing is carried out in thermoregulated aquaria with continuous flow of water. The bio-assay installation (Swedmark et al., 1971, 1973) permits the testing at several concentrations and of several species at a time.

The special water flow system is described by Granmo & Kollberg (1972).

This method has been used for testing the acute effects of surfactants, dispersants, oil emulsions and oil on marine animals.

Two modifications of this biotest system are described by Nagell et al. (1974) and Bengtsson et al. (1975).

REFERENCES:

- BENGTSSON B.-E., CARLIN C.H., LARSSON Å. & SVANBERG O. (1975) Vertebral damage in minnows, Phoxinus phoxinus L., exposed to cadmium. Ambio, 4(4), 166-168.
- GRANMO Å. & KOLLBERG S.O. (1972) A new simple water flow system for accurate continuous flow tests. Water Research 6, 1597-1599.
- NAGELL B., NOTINI M. & GRAHN O. (1974) Toxicity of four oil dispersants to some animals from the Baltic Sea. Mar.Biol. 28, 237-243.
- SWEDMARK M., BRAATEN B., EMANUELSSON F. & GRANMO Å. (1971) Biological effects of surface active agents on marine animals. Mar.Biol. 9, 183-201.
- SWEDMARK M., GRANMO Å. & KOLLBERG S.O. (1973) Effects of oil dispersants and oil emulsions on marine animals. Water Research 7, 1649-1672.

ACUTE EFFECTS II

- PARAMETER STUDIED: Mortality expressed as 96-h LC50.
- TEST ANIMALS: Fish, bivalves and crustaceans. They represent different biological types and modes of life.
- EXPERIMENTAL CONDITIONS: The testing is carried out under static conditions in glass aquaria containing 50 l of water (the water volume depends on the number and size of the animals in each aquarium). The temperature is about 12°C. Mortality and behaviour is recorded continuously during the experiment.
- This method is commonly used at different laboratories. It should however only be used for short-time experiments.
- REFERENCES: SVANBERG O., LARSSON Å. & BENGTSSON B.-E. (1976). Akut toxicitet och ackumulering av PCB vid höga halter i vatten. NBL Rapp. 19 (Only in Swedish).

ACUTE EFFECTS III-
SUBLETHAL EFFECTS I

- PARAMETER STUDIED: Mortality, reproduction and growth rate.
- TEST ANIMALS: Ophryotrocha labronica LA GRECA & BACCI.
- EXPERIMENTAL CONDITIONS: The testing is carried out under static conditions in covered bowls with a volume of 15 and 80 ml, respectively. The water is changed once or twice a week (salinity: 32-34%). The water is filtered and sterilized by heating to 80-90°C. The test animals are fed with ordinary frozen spinach.
- The experiments always start with a population of newly hatched O. labronica larvae (approximately 75 larvae in each bowl).
- Once or twice a week the body length and the number of parapodia of 10 test animals in each bowl are recorded. The presence of egg masses is checked every day.
- REFERENCES: ÅKESSON B. (1970) Ophryotrocha labronica as test animal for the study of marine pollution. Helgoländer wiss. Meeresunters., 20, 293-303.

SUBLETHAL EFFECTS II

- PARAMETER STUDIED: Movement pattern
- TEST ANIMALS: Fish
- EXPERIMENTAL CONDITIONS: The testing is carried out in a test tank in which a wide

acrylic plastic tube with a smaller inner tube forms a circular aquarium with a volume of 50 l. The test tank is placed in a room provided a photoperiodicity of 12 h light and 12 h dark. The recording of light beam interruptions by the fish is performed with i.r.-diode/photoreceptor sets placed serially at points ranging from close to the bottom to the surface. The testing is carried out under continuous flow conditions.

REFERENCES: BENGTTSSON B.-E. (1974) Effect of zinc on the movement pattern of the minnow, Phoxinus phoxinus L. Water Research, 8, 829-833.

SUBLETHAL EFFECTS III

PARAMETER STUDIED: Coordination and reflex mechanisms.

TEST ANIMALS: Fish

EXPERIMENTAL
CONDITIONS:

The animals (test and control) are kept in throughs containing 30 litres of tapwater and the toxic substance is added to those containing test groups. The fish are removed from the throughs after different periods of exposure.

At the end of the period of exposure the fish are placed one by one in a rotatory-flow apparatus for 30 minutes to become acclimatized. After the period of acclimatization each fish is subjected to rotation ten times at 5-minute intervals. The critical r.p.m. is determined for each fish.

The method can be used under field conditions.

REFERENCES: LINDAHL P.E. & SCHWANBOM E. (1971) A method for the detection and quantitative estimation of sublethal poisoning in living fish. Oikos, 22, 210-214.

LINDAHL P.E. & SCHWANBOM E. (1971) Rotatory flow technique as a means of detecting sublethal poisoning in fish populations. Oikos, 22, 354-357.

SUBLETHAL EFFECTS IV

PARAMETERS STUDIED: Opercular movements of fish and locomotory behaviour of mobile species. The formation of new byssal threads after daily removal (common mussel). The ability to close the valves (bivalves). Burrowing and siphon reaction (cockles and clams). Response to food (fish and crustaceans). Hatching rates and development of eggs and larvae.

TEST ANIMALS: Fish, crustaceans and bivalves. Eggs and larvae of cod, common mussel and lobster.

EXPERIMENTAL
CONDITIONS:

The same as for ACUTE EFFECTS I. The exposure periods are however somewhat longer.

REFERENCES: SWEDMARK M. (1974) Toxicity testing at Kristineberg Zoological station. /in: Proceedings from a Workshop on Ecological Aspects of the Toxicity Testing of Oils and Dispersants, UK Institute of Petroleum, London Dec. 1972. Ed. BEYNON & COWELL/ pp. 41-51.

SUBLETHAL EFFECTS V

PARAMETERS STUDIED: Hematocrit, hemoglobin, blood glucose, blood lactate, muscle and liver glycogen, plasma content of potassium, calcium, magnesium and inorganic phosphate.

TEST ANIMALS: Fish

EXPERIMENTAL CONDITIONS: The biotest system, which is principally the same as for ACUTE EFFECTS I, is described by Bengtsson et al. (1975). After exposure (4 and 9 weeks) the fish are removed from the water and immediately stunned with a blow on the head. The standardized sampling procedures for blood, liver and muscle tissue, as well as the routine clinical methods are described in detail by Larsson (1972).

REFERENCES: BENGTTSSON B.-E., CARLIN C.H., LARSSON Å. & SVANBERG O. (1975) Vertebral damage in minnows, Phoxinus phoxinus L., exposed to cadmium. *Ambio*, 4(4), 166-168.

LARSSON Å. (1972) Metabolic studies in eels. Ph.D.-thesis from the Department of Zoophysiology, University of Göteborg.

LARSSON Å. (1975) Some biochemical effects of cadmium on fish. /in: *Sublethal Effects of Toxic Chemicals on Aquatic Animals*. Ed. KOEMAN J.H. & STRIK J.J.T.W.A., Elsevier Scientific Publishing Company-Amsterdam/ pp. 3-13.

ACCUMULATION I

PARAMETER STUDIED: The cadmium concentration in blood, muscle, liver, kidney and gills after 1, 2, 3, 4, 5, 7, and 9 weeks exposure to cadmium at different concentrations.

TEST ANIMALS: Fish (Pleuronectes flesus and Alburnus alburnus)

EXPERIMENTAL CONDITIONS: The testing is carried out in four PCV-tanks (400l) with a continuous flow of brackish water from the Baltic Sea (120 l/h). Salinity: 7‰. Temperatur: about 10°C. Number of fishes/tank: 35. The test animals are fed during the whole experiment. The test substance is dosed by a peristaltic pump. The concentration of cadmium in each aquarium is checked once a week.

The cadmium concentration in water and different organs is determined by neutron activation analysis.

REFERENCES: BENGTTSSON B.-E. (1976) Ackumulering av kadmium i skrubbskädda, Pleuronectes flesus, och löja, Alburnus alburnus NBL Rapp. 32 (Only in Swedish)

LARSSON Å. (1975) Some biochemical effects of cadmium on fish./in: *Sublethal Effects of Toxic Chemicals on Aquatic Animals*. Ed. KOEMAN J.H. & STRIK J.J.T.W.A., Elsevier Scientific Publishing Company-Amsterdam/pp. 3-13.

ACCUMULATION II-
ELIMINATION I

- PARAMETER STUDIED: The whole body content of the toxic substances (DDT, dieldrin, penta- and hexachloroethane and trichlorobenzene) expressed on fat basis.
- TEST ANIMALS: Gasterosteus aculeatus (stickleback) and Pleuronectes flesus (flounder).
- EXPERIMENTAL CONDITIONS: The testing is carried out in 50 l aquaria at 11°C with a continuous flow of water (24 l/h). The testing is carried out over an accumulation (4-15 days) and an elimination (about 3 weeks) period. The test animals are sampled several times during the experiment. At the same time water samples are taken.
- The analytical methods used are described in detail by Jensen & Renberg (1975).
- REFERENCES: JENSEN S. & RENBERG L. (1975) Elimination of some chlorinated hydrocarbons from stickleback and juvenile flounder. Scientific Report to the Oslo Commission Working Group on degradability. May 1975.

CONVENTION POUR LA PREVENTION DE LA POLLUTION MARINE PAR LES OPERATIONS
D'IMMERSION EFFECTUEES PAR LES NAVIRES ET AERONEFS

QUATRIEME REUNION DU COMITE CONSULTATIF PERMANENT SUR CONSEILS
SCIENTIFIQUES

NANTES LE 8-10 SEPTEMBRE 1976

METHODES EMPLOYEES DANS CERTAINS LABORATOIRES SUEDOIS POUR L'ESTIMATION
DES EFFETS AIGUS ET SUB-LETAUX, ET DE L'ACCUMULATION DE SUBSTANCES
TOXIQUES CHEZ LES ANIMAUX AQUATIQUES

METHODES EMPLOYEES DANS CERTAINS LABORATOIRES SUEDOIS POUR L'ESTIMATION
DES EFFETS AIGUS ET SUB-LETAUX, ET DE L'ACCUMULATION DE SUBSTANCES
TOXIQUES CHEZ LES ANIMAUX AQUATIQUES

EFFETS AIGUS I

PARAMETRES ETUDIES : Mortalité exprimée à la fois en temps médian de survie et en 96-h LC50.

Critère de mort : Cessation de la respiration et et des mouvements du corps (poissons et crustacés). Inactivation complète des muscles adducteurs et des muscles de la lisière du manteau (bivalves).

ANIMAUX DE TEST : Poissons, crustacés et bivalves. Ils représentent des types biologiques et des modes de vie différents.

CONDITIONS

EXPERIMENTALES : L'estimation se fait dans des aquariums à thermorégulateurs à courant d'eau continu. L'installation pour essais biologiques (Swedmark et al., 1971, 1973) permet de pratiquer l'estimation à plusieurs concentrations et pour plusieurs espèces à la fois.

Le système spécial de courant d'eau est décrit par Granmo & Kollberg (1972).

Cette méthode a été utilisée pour l'estimation des effets aigus des agents actifs de surface, des dispersants des émulsions de pétrole et du pétrole sur des animaux marins.

Deux modifications de ce système de tests biologiques sont décrites par Nagell et al. (1974) et Bengtsson et al. (1975).

- REFERENCES :
- BENGTSSON B.-E., CARLIN C.H., LARSSON Å. & SVANBERG O. (1975) Dégâts causés aux vertèbres des vairons, Phoxinus phoxinus L., soumis aux effets du cadmium. Ambio, 4 (4), 166 - 168.
- GRANMO. & KOLLBERG S.O. (1972) Un système simple et nouveau de courant d'eau pour des tests précis en flots continus. Water Research 6, 1597 - 1599.

NAGELL B., NOTINI M. & GRAHN O. (1974) toxicité de quatre dispersants du pétrole chez certains animaux de la mer Baltique. Mar. Biol. 28, 237 - 243.

SWEDMARK M., BRAATEN B., EMANUELSSON F. & GRANMO Å. (1971) Effets biologiques d'agents de surface actifs sur des animaux marins. Mar. Biol. 9, 183 - 201.

SWEDMARK M., GRANMO Å. & KOLLBERG S.O. (1973) Effets des dispersants du pétrole et des émulsions de pétrole sur des animaux marins. Water Research 7, 1649 - 1672.

EFFETS AIGUS II

PARAMETRES ETUDIES: Mortalité exprimée en 96-h LC50.

ANIMAUX DE TEST : Poissons, bivalves et crustacés. Ils représentent des types et modes de vie biologiques différents.

CONDITIONS

EXPERIMENTALES : L'estimation se fait dans des conditions statiques, en aquariums de verre contenant 50 l. d'eau (le volume d'eau dépend du nombre et de la taille des animaux dans chaque aquarium). La température est d'environ 12°C. Le comportement et la mortalité sont enregistrés continuellement au cours de l'expérience.

Cette méthode est utilisée communément dans différents laboratoires. Cependant, elle doit être utilisée seulement pour des expériences de courte durée.

- REFERENCES :
- SVANBERG O., LARSSON Å. & BENGTSSON B. - E. (1976). Akut toxicitet och ackumulering av PCB vid hoga halter ivatten. NBL Rapp. 19 (en Suédois seulement).

EFFETS AIGUS III

EFFETS SUB-LETAUX I

PARAMETRES ETUDIES: Mortalité, reproduction et taux de croissance.

ANIMAUX DE TEST : Ophryotrocha Labronica LA CRECA & BACCI.

CONDITIONS

EXPERIMENTALES : L'estimation se fait sous conditions statiques, dans des bols couverts, d'un volume de 15 et 80 ml., respectivement.

L'eau est changée une ou deux fois par semaine (salinité 32 - 34 ‰). L'eau est filtrée et stérilisée en chauffant à 80 - 90°C. Les animaux de test sont nourris avec des épinards surgelés ordinaires.

L'expérience commence toujours avec une population de larves d'O Labronica fraîchement écloses (à peu près 75 larves dans chaque bol). Une ou deux fois par semaine, la longueur du corps et le nombre de parapodes de 10 animaux de test de chaque bol sont enregistrés. On vérifie chaque jour la présence de masses d'oeufs.

REFERENCES : ÅKESSON B. (1970) Ophryotrocha labronica comme animal de test pour l'étude de la pollution marine. Helgolander wiss. Meeresunters., 20, 293 - 303.

EFFETS

SUB-LETAUX II

PARAMETRES ETUDIES: Arrangement des mouvements.

ANIMAUX DE TEST : Poissons.

CONDITIONS

EXPERIMENTALES : L'estimation se fait dans un bac de test dans lequel un large tube intérieur plus petit, forme un aquarium circulaire d'un volume de 50 l. Le bac de test est placé dans une salle où une photopériodicité de 12 h. de lumière et 12 h. d'obscurité a été installée. L'enregistrement des interruptions de faisceaux lumineux par le poisson est assuré par des appareils i.r.-diode/photorécepteurs placés en série à des points étagés depuis un niveau près du fond jusqu'à la surface. L'estimation se fait dans des conditions de flot continu.

REFERENCES : BENGTTSSON B.-E. (1974) Effet du zinc sur l'arrangement des mouvements du vairon, Phoxinus phoxinus L. Water Research, 8, 829 - 833.

EFFETS
SUB-LETAUX III

PARAMETRES ETUDIES: Coordination et mécanismes de réflexes.

ANIMAUX DE TEST : Poissons.

CONDITIONS EXPERIMENTALES : Les animaux (de test et de contrôle) sont placés dans des auges contenant 30 litres d'eau de ville et la substance

toxique est ajoutée à celles qui contiennent les groupes de test. Les poissons sont retirés de ces auges après des périodes d'exposition variées.

A la fin de la période d'exposition, les poissons sont placés, un par un, dans un appareil à flot rotatoire pendant 30 minutes, pour s'y acclimater. Après cette période d'acclimatation, chaque poisson est soumis à la rotation dix fois, à des intervalles de 5 minutes. La r.p.m. critique est déterminée pour chaque poisson.

La méthode peut être utilisée dans des conditions naturelles.

REFERENCES : LINDAHL P.E. & SCHWANBOM E. (1971) Une méthode pour la détection et l'estimation quantitative d'empoisonnement sub-létal chez le poisson vivant. Oikos, 22, 210 - 214.

LINDAHL P.E. & SCHWANBOM E. (1971) Technique à flot rotatoire comme moyen de détection d'empoisonnement sub-létal dans des populations de poissons. Oikos, 22, 354 - 357.

EFFETS
SUB-LETAUX IV

PARAMETRES ETUDIES: Mouvements opercules chez les poissons et comportement locomoteur d'espèces mobiles. La formation de nouveaux byssus après que ceux déjà formés aient été enlevés journallement (moules communes). Pouvoir de refermer les valves (bivalves). Aptitude à s'enterrer et réaction du siphon (clovisses et palourdes). Réponse à la nourriture (poissons et crustacés). Taux d'éclosion et de développement des oeufs et des larves.

- ANIMAUX DE TEST : Poissons, crustacés et bivalves. Oeufs et larves de morue, moule commune et homard.
- CONDITIONS EXPERIMENTALES : Les mêmes que pour les EFFETS AIGUS I. Cependant, les périodes d'exposition sont un peu plus longues.
- REFERENCES : SWEDMARK M. (1974) Estimation de toxicité à la station zoologique de Kristineberg dans : Débats d'un groupe de travail sur des aspects écologiques de l'estimation de la toxicité des pétroles et dispersants, UK Institute of Petroleum, Londres, Déc. 1972. Ed. BEYNON & COWELL pp. 41 - 51.

EFFETS
SUB-LÉTAUX V

PARAMETRES ETUDIES: Hématocrite, hémoglobine, glucose sanguin, lactate sanguin, glycogène du muscle et du foie, contenu en potassium, calcium, magnésium et phosphate inorganique du plasma.

ANIMAUX DE TEST : Poissons.

CONDITIONS EXPERIMENTALES : Le système de tests biologiques qui est essentiellement le même que pour les EFFETS AIGUS I, est décrit par BENGTTSSON et al. (1975).

Après exposition (4 à 9 semaines), les poissons sont retirés de l'eau et immédiatement étourdis par un coup sur la tête. Les procédés standardisés pour le prélèvement d'échantillons de sang, de foie et du tissu musculaire, ainsi que les méthodes cliniques usuelles sont décrites en détails par Larsson (1972).

REFERENCES : BENGTTSSON B.E., CARLIN C.H., LARSSON Å. & SVANBERG O. (1975) Dégâts causés aux vertèbres des vairons, Phoxinus phoxinus L., soumis à l'action du cadmium. Ambio, 4 (4), 166 - 168.

LARSSON Å. (1972) Etudes métaboliques chez les anguilles. Thèse de Doctorat dans le département de Zoophysologie, Université de Göteborg.

LARSSON Å. (1975) Quelques effets bio-chimiques du cadmium sur les poissons, dans : Effets sub-létaux de produits chimiques toxiques sur des animaux aquatiques. Ed. KOEMAN J.H. & STRIK J.J.T.W.A., Elsevier Scientific Publishing Company, Amsterdam pp. 3 - 13.

ACCUMULATION I

- PARAMETRES ETUDIES: La concentration en cadmium dans le sang, les muscles, le foie, les reins et les oufes après 1, 2, 3, 4, 5, 7 et 9 semaines d'exposition au cadmium, à des concentrations diverses.
- ANIMAUX DE TEST : Poissons (Pleuronectès flesus et Alburnus alburnus)
- CONDITIONS EXPERIMENTALES : L'estimation se fait dans quatre bacs en plastique (400l) avec un flot continu d'eau saumâtre de la mer Baltique (120 l/h.). Salinité : 7 ‰. Température : à peu près 10 °C. Nombre de poissons/bac : 35.

Les animaux sont nourris pendant toute la durée de l'expérience. La substance du test est dosée par une pompe péristaltique. La concentration en cadmium dans chaque aquarium est vérifiée une fois par semaine.

La concentration de cadmium dans l'eau et les différents organes est déterminée par l'analyse de l'activation par les neutrons.

- REFERENCES : BENGTSSON B.-E. (1976) Ackumulering av kadmium i skrubb-skadda, Pleuronectes flesus, och loja, Alburnus alburnus NBL Rapp. 32 (en Suédois seulement)
- LARSSON Å. (1975) Quelques effets biologiques du cadmium sur les poissons, dans : Effets Sub-létaux de produits chimiques toxiques sur des animaux aquatiques. Ed. KOEMAN J. H. & STRIK J.J.T.W.A., Elsevier Scientific Publishing Company, Amsterdam, pp. 3 - 13.

ACCUMULATION II
ELIMINATION I

- PARAMETRES ETUDIES: Le contenu en substances toxiques (DDT, diéldrine, penta-
et hexachloro-éthane et trichlorobenzène) exprimé en unité
de matière grasse.
- ANIMAUX DE TEST : Gasterosteus aculeatus (épinocche) et Pleuronectes (carrelet).
- CONDITIONS
EXPERIMENTALES : L'estimation est faite dans des aquariums de 50 l. à 11°C.
avec un flot continu d'eau (24 l/h). L'estimation se fait
pendant une période d'accumulation (4 - 15 jours) et une
période d'élimination (à peu près 3 semaines). On fait des
dosages sur les animaux de test plusieurs fois pendant
l'expérience. En même temps, des échantillons d'eau sont
prélevés.
- Les méthodes analytiques utilisées sont décrites en détail
par Jensen & Renberg (1975).
- REFERENCES : JENSEN S. & RENBERG L. (1975) Elimination de certains
hydrocarbures chlorurés chez l'épinocche et le jeune carrelet.
Scientific Report to the Oslo Commission Working Group on
degradability. Mai 1975.

CENTRAAL LABORATORIUM TNO
DELFT

D 76/55
16-5-1976

1. Determination of the Degradability of Organic Compounds.
2. The Die-Away Test of a Substrate in Shake Flasks.

by Ir. J.F. de Kreuk

translated by G.P.M. Léger

1. Determination of the degradability of organic compounds

1.1. Introduction

A compound is considered degradable if in a certain medium it can be transformed by microorganisms. If a compound cannot so be degraded in the laboratory, it is called "recalcitrant" (Alexander, 1965). If the degradation products are inorganic compounds only, the degradation is called mineralization. The term persistence usually denotes an extreme degree of recalcitrance. A persistent compound is not degraded under any environmental conditions.

Some of the conditions prevailing in a laboratory experiment may be such that a compound which is in itself degradable behaves as a recalcitrant compound. Of these conditions the most important are (Alexander, 1973):

- 1) the test medium does not contain an active degrading organism.
- 2) the compound itself or its degradation products are toxic towards the degrading organisms.
- 3) because of low solubility, adsorbability, or for other reasons, the concentration of the substance may be so low, or its

- accessibility so poor, that no detectable degradation takes place
- 4) the substance does not, e.g. because of its low concentration, promote the synthesis of degrading enzymes by the microorganism.
 - 5) the substance is only degraded by a series of different species of microorganisms, which carry out consecutive degradation reactions. The conditions promoting successive steps may differ so strongly (e.g. aerobic vs. anaerobic) that they can only obtain in separate parts of the environment.

Some compounds that are by themselves recalcitrant can still be degraded in the presence of a chemically related degradable compound ("cooxidation" or "cometabolism").

In that case the substance itself is unable to induce formation of the requisite degradation enzymes, although it does "match" the enzymes induced by the degradable compound.

In the next Sections, a description will be given of the die-away test and its most important phases, namely the selection of a medium, a microbiological inoculum, and an analytical method for the determination of the substance to be investigated (the substrate).

1.2. The die-away test

In a die-away test the substrate is added to a definite amount of a medium containing bacteria. During the incubation period, the concentration of substrate is determined at regular intervals. The decrease in concentration (the "dying-away") is taken as the criterion of degradability. It is assumed that the processes taking place during the test are the same as those occurring in a "compartment" of water which has received a single discharge without being diluted. Since the procedure is a very simple one, requiring nothing but an erlenmeyer flask, the substrate need not meet any specific demands. Provided that an analytical method is available for its determination, it can be soluble or insoluble in the medium, a liquid or a solid. In its initial concentration the substrate should on no

account be toxic to the microflora present in the medium. Unless there is certainty that the substrate in the concentration added is non-toxic, its toxicity has to be determined. This can be done by determining the influence of the substrate on the growth of a sensitive microorganism. The non-occurrence of degradation may be ascribed to one of the causes outlined in Section 1.1. As a check on the experimental conditions, one determines in a parallel experiment the degradability of a compound that is chemically related to the substrate and whose behaviour is known. If the parallel experiment reveals that the degradation behaviour of the compound is abnormal, the experiment has to be repeated. Changes in the substrate may result not only from biological degradation, but also from chemical changes in the medium. If one wishes to assess the latter, it is necessary to conduct a sterile test analogous to the degradation test. If possible the medium is sterilized by filtration. The glassware and filter holders (with the filters) are treated in an autoclave. If filtration is impossible, for example because the substrate contains a solid, the medium can be sterilized by means of a mercuric chloride solution.

1.3. Media

Die-away tests can be conducted in natural sea water collected from a non polluted source (e.g. the open sea), or in artificial sea water prepared from commercially available sea salt, e.g. Wiegandt's sea salt. The salinity of sea water so prepared should be 29 ‰. If the concentration of substrate (expressed as organic carbon) exceeds 10 mg/l, an extra supply of inorganic nitrogen and phosphorus compounds should be added to the medium. The growth of the degrading organisms should not be limited by factors other than the concentration of the substrate and its degradability. Such factors would so strongly impair the degradation that the substrate would wrongly be inferred to be recalcitrant. In general, the ratio (w/w) carbon : nitrogen should not exceed 10,

and the ratio nitrogen : phosphorus should be at most 5. Unless the substrate is toxic, its best concentration in a die-away test lies between 30 and 100 mg/l. The pH of medium plus substrate should lie between 8.0 and 8.4. As a rule microorganisms are not sensitive to slight changes in the composition of the sea water of the medium as long as its osmotic pressure and pH are the same as those of sea water. Another proviso is that the supply of nutrient salts should be adequate. For this reason it is possible to use media other than sea water provided that their osmotic pressure is adjusted with NaCl. Aaronson (1970) has given an extensive and useful survey of media suitable for certain groups of compounds.

1.4. Microbiological inocula

A microbiological inoculum is a collection of microorganisms added to the medium in order to effect degradation. Sources of microorganisms for tests in sea water are the following: coastal water, bottom sediment, tidal flat sediment, bottom sediment from the low tide mark, sea water from the area that is receiving waste or will later receive waste, etc.

From silt or bottom sediment an inoculum can be made by shaking it with sea water, allowing the solid matter to settle, and filtering over coarse filter paper. The inoculum added in a test should contain enough microorganisms to give a concentration of 10^4 /ml (the usual concentration in sea water). It should be borne in mind that the manipulations with the inoculum and the necessity of adjusting to a new medium will cause a number of microorganisms to die. An inoculum that is too dilute can be concentrated by centrifugation. The number of bacteria per ml can be determined by one of two important methods:

- a) determination of ATP concentration ; 10^4 bacteria per ml correspond to an ATP concentration of 0.01 - 0.1 ng ATP/ml.
- b) viable counts ; a number of 10^3 - 10^4 colony forming bacteria in a count correspond to 10^4 bacteria per ml.

1.5. Determination of substrate

It should be possible to determine the concentration of substrate in the medium. For this purpose there are a number of general analytical methods:

- determination of total organic carbon (TOC)
- determination of total oxygen demand (TOD)
- determination of chemical oxygen demand (COD)
- determination of oxygen uptake by microorganisms
(biological oxygen demand, BOD)
- determination of total organic chlorine (TOCl) if necessary.

In addition there are a number of more specific methods, e.g. gas chromatography and colorimetric determinations. With the general, non-specific methods, the mineralizability of the substrate is determined, whereas a compound-specific analysis reveals even slight changes in the molecules of the substrate. As a testing criterion mineralizability is preferable, and a specific analysis is resorted to only if unavoidable.

It should be borne in mind that part of the organic matter may be assimilated and converted into biomass instead of being transformed into inorganic matter. If the biomass is removed before analysis, the mineralizability that is subsequently measured also represents the extent to which the substrate is converted into "natural material". If the medium contains the substrate in suspension or in emulsion, the biomass cannot be removed. In that case it should be borne in mind that the mineralization measured corresponds to only a part of the total amount of substrate degraded. The determination of TOC, if necessary together with a determination of total organic chlorine, provides the most direct information about mineralizability. This is true in lesser degree of the determination of COD or TOD, because the partial oxidation of a molecule, with impunity to its carbon skeleton, still produces a decrease in these quantities.

From the direct measurement of oxygen uptake the mineralization can be calculated only if the theoretically possible oxygen uptake is known. A compound-specific analysis allows determination of mineralization

only if the intermediates and end products are known. In the following cases, however, compound-specific analysis is required:

- when the lower detection limit of a general method is too high for the low concentration at which a toxic or poorly soluble substrate has to be tested. In general the initial concentration of substrate should be at least ten times the said detection limit, because this allows determination of a 90% degradability.
- when mineralization of a substrate consisting of several compounds is incomplete. Specific analysis then reveals which of the compounds is mineralizable to what extent.

1.6. Literature

- Aaronson, S. (1970) - Experimental Microbial Ecology.
Academic Press, New York and London.
- Alexander, M. (1965) - Advan. Appl. Microbiol. 7, 35.
- Alexander, M. (1973) - Non biodegradable and other recalcitrant molecules.
Biotechn. and Bioeng. 15, 611-647.

2. The die-away test of a substrate in shake flasks

Subject : Determination of biological degradability

2.1. Area of application

The test is suitable for the investigation of substrates in sea water as well as in fresh water. The nature of the substrate is not subject to any special limitations. It does not matter, for example, whether it is soluble or insoluble in the medium, or whether it is a solid or a liquid. The test is also suitable for the investigation of compounds labelled with radioactive isotopes.

2.2. Principle of the method

The substrate is added as the sole source of carbon to the inorganic nutrient medium. The medium is inoculated with micro-organisms and shaken in a flask on a mechanical shaker. Samples of medium are taken at regular intervals and the concentrations of substrate they contain are determined. The time needed for complete or almost complete degradation is taken as an (inverse) measure of degradability. A blank experiment without bacteria (i.e. under sterile conditions) reveals how much of the substrate escapes degradation through adsorption, evaporation or chemical reactions (e.g. hydrolysis).

2.3. Equipment

- Mechanical shaker
- A cupboard or other space in which the temperature can be kept constant
- ♦ The substrate is a compound or mixture of compounds that is to be tested for biodegradability.

- Erlenmeyer flasks
 - Pipettes for the removal of samples (pipette volume depends on analytical method chosen)
 - Sample bottles
 - Alkali, mineral acid, or a deep freezer (-20°C), depending on analytical method, for the preservation of samples
 - nutrient medium (see Section 1.3.)
 - Microbiological inoculum (see Section 1.4.)
- and further, for the sterile blank test:
- An autoclave
 - Filtering equipment (e.g. a pressure filter and/or a syringe with a filter attachment)
 - Membrane filters, pore size $0.2\ \mu\text{m}$
 - 10% mercuric chloride solution (failing other sterilization methods)
 - Nutrient broth.

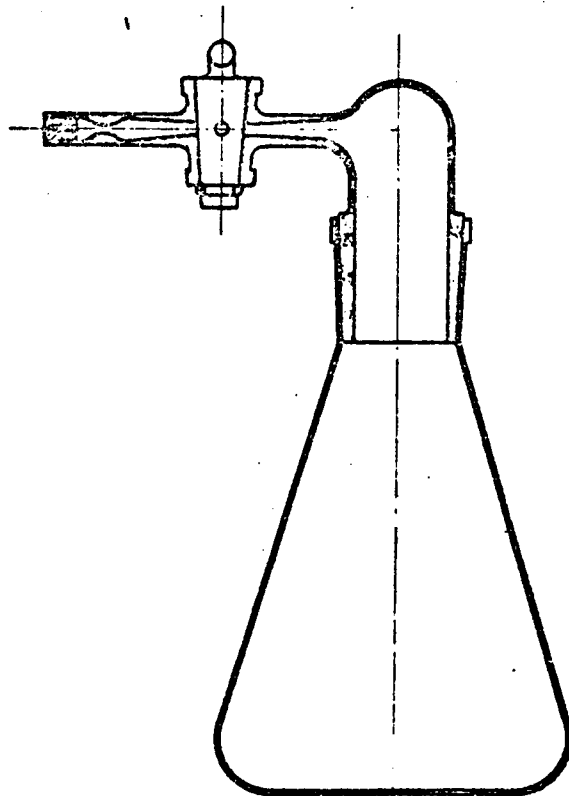

Figure 1.

Erlenmeyer flask for die-away test,
with special stopper (half size).

2.4. Procedure

The data required for selecting the experimental conditions are to be found in Chapter 1.

- a) For each condition, the test is conducted in duplicate. If the substrate is not homogeneous, or if it appears that the inoculum does not grow easily, the test is conducted in triplicate or even quadruplicate.
- b) The erlenmeyer flasks are not to be filled to more than one third of their capacity (100 ml of medium in a 300 ml flask; see remark no. 1).
- c) The substrate should be added to the freshly prepared medium (see Section 1.4.).
- d) A suitable inoculum (see Section 1.3.) is prepared and added to the medium.
- e) Medium, substrate and inoculum are thoroughly mixed and the mixture transferred to the flasks in equal amounts.
- f) The flasks are stoppered with wads of cotton wool. If the substrate is volatile or radioactive, they should be stoppered with special glass stoppers through which samples can be taken with a syringe (see Figure 1).
The stopcock prevents loss of substrate by diffusion across the injection rubber.
- g) The flasks are incubated on a mechanical shaker in the dark at 25 °C and shaken at least 150 rounds a minute (see remarks nos. 2 and 3).
- h) Samples are removed for analysis on the 0th, 3rd, 5th, 7th day and so on (on alternate days, see remark no. 4). The test is terminated within two months.
- i) The results are calculated from the formula

$$\text{percentage degradation} = \frac{C_0 - C_t}{C_0} \times 100$$

where C_0 is the substrate concentration at the beginning of the test, and C_t the concentration at time t .

The percentages so calculated are plotted as a function of time.

The preparation of the sterile blank requires the following extra manipulations.

- j) The flasks (stoppered with wads of cotton wool or wrapped in filter paper), the filter holders (with the filters mounted) and the nutrient broths are sterilized for 20 minutes in an autoclave at 120 °C (it is better to sterilize sea water by filtration).

It is usually impossible to sterilize the substrate by heating because of possible chemical changes.

- k) The sterilized medium is transferred under aseptic conditions to the sterile flasks. Such conditions are maintained in a laminar flow cabinet using a flow of sterile air, or in a specially designed inoculation space. A draught-free laboratory space is also suitable provided that it is not used for experiments with microorganisms.
- l) The substrate is sterilized by filtration. It is aspirated into a syringe, a sterile filtering attachment is mounted on the syringe, and the substrate is forced through the filter directly into the sterile flasks (see remark no. 6).
- m) At the end of the test a sample is removed for analysis and a check is made on the sterility of the blank by removing one ml of it and adding this to 100 ml of sterile nutrient broth. Upon incubation the broth should not become turbid within 48 hrs (see remark no. 7).

2.5. Remarks

- (1) If the aggregate volume of the samples is more than half the volume of the medium, the test should be conducted in larger flasks, with the proviso that the volume of the medium should not be more than one third of the volume of the flask.

- (2) If desired the test can be conducted at a lower temperature that is closer to that of the receiving water body.

In that case degradation is slower and sometimes less complete. Since there is no known relation between the rate of degradation in the laboratory and that in nature, and since biodegradability is here determined as a compound-specific property, the usual practice is to conduct the test at 25 °C, so that it consumes less time.

- (3) The flasks are incubated on a mechanical shaker so as to ensure adequate aeration and mixing. Both depend on the shaking pattern (e.g. the amplitude) and higher shaking frequencies (up to 350 shakings a minute) may sometimes be needed, particularly if the substrate is readily degradable, or if its concentration is high (more than about 0.5 g per litre).
- (4) The sampling frequency can be adjusted to the degradability of the substrate. If the prescribed frequency does not yield sufficient information, it should be increased, and samples should be taken daily. The usual scheme of sampling on alternate days can be adhered to if the substrate is degraded in about 20 days. If the degradation takes more time, it suffices to take samples twice a week.
- (5) If one wishes to determine the extent to which the substrate suffers chemical degradation, a sterile blank test is run. The pH of the medium in the ordinary test and that in the blank test should not differ by more than 0.1.
- (6) Substrates which contain solids or components that are strongly adsorbed by filters cannot be sterilized by filtration. If, in addition, sterilization in an autoclave is undesirable, the substrate can be sterilized by addition of 1 ml of a 10% mercuric chloride solution to 100 ml of medium. The possible interference of mercury in the analysis of the samples should be borne in mind.
- (7) If intermediate sampling is necessary, it is recommended to run so many blanks that there is one for each analysis.

STANDING ADVISORY COMMITTEE FOR SCIENTIFIC ADVICE

SIXTH MEETING

COPENHAGEN: 19 - 22 SEPTEMBER 1978

TITLE: TEST PROCEDURES UNDER THE "PRIOR CONSULTATION
PROCEDURES"

PRESENTED BY: FRANCE
IRELAND
THE NETHERLANDS
THE UNITED KINGDOM

AGENDA ITEM: SEVEN

ORIGIN: SACSA PAPERS: SACSA 76 (6)
SACSA 76 (9)
SACSA 76 (10)
SACSA 77 (19)

CONVENTION FOR THE PREVENTION OF MARINE POLLUTION BY DUMPING FROM SHIPS AND AIRCRAFT

SIXTH MEETING OF THE STANDING ADVISORY COMMITTEE FOR SCIENTIFIC ADVICE

COPENHAGEN: 19 - 22 SEPTEMBER 1978

TEST PROCEDURES UNDER THE "PRIOR CONSULTATION PROCEDURES"

1. At the Fifth SACS Meeting the French delegation submitted a revised version of the descriptions of the following tests:-
 - (a) recovery test
 - (b) inhibition of the growth of phytoplankton.
2. Since then, comments on these have been received from the Netherlands.
3. The Netherlands also commented on the B.O.D. tests submitted by Ireland (SACSA(76)(6)), and the acute toxicity tests submitted by the United Kingdom (SACSA(76)(10)).
4. The United Kingdom replied to the comments from the Netherlands.
5. Attached are the comments by the Netherlands, annexed to which are the test descriptions and the reply by the United Kingdom.

CONVENTION FOR THE PREVENTION OF MARINE POLLUTION BY DUMPING FROM SHIPS
AND AIRCRAFT

SIXTH MEETING OF THE STANDING ADVISORY COMMITTEE FOR SCIENTIFIC ADVICE

COPENHAGEN: 19 - 22 SEPTEMBER 1978

Methodology of tests (growth of phytoplankton)

SACSA 77 (19). Presented by France.

The test is concerned with the inhibition of the growth of phytoplankton, and in concept it is identical to most procedures published on this kind of tests.

General

The general list of criteria used in the test lacks a statement of the pH of the medium, and of any changes it may undergo during the test. The toxicity of weak acids depends strongly on pH.

Specific

The test procedure that is given as an example describes neither how the test organisms are grown, stored and handled, nor how inocula are prepared from them (dilution? centrifugation?).

The meaning of "cells from a pure stock" is not clear. Does it mean that the cultures are free from bacteria, or that they should be handled aseptically?

It is uncertain whether by "incubation temperature" is meant the temperature in the test tubes or that of the constant-temperature room. Depending on the test method, the former may be several degrees higher than the latter. The kind of light source is not mentioned, nor is it stated that each test tube should be exposed to the same light intensity.

Is it necessary to incubate an organism under a day/night regime?

Results in the Netherlands indicate that in toxicity tests it makes little difference whether cultures are incubated under continuous light or intermittent light.

The concentration of algal cells at the beginning of the test is such that they can be easily counted in a Coulter Counter, but is it possible to measure the optical density of the cultures directly? The meaning of "TRIS" (a constituent of solution IV) is not clear. What are the effects of heat sterilization on the seawater medium? Does the pH remain constant, and are any precipitates formed? Why not sterilize by filtration?

A method for calculating the growth rate and the point of 50% inhibition should be given.

A statement of the number of dilutions needed to calculate a growth inhibition of 50% is lacking.

An alternative is to state the reduction in the total number of cells in a given time, and to calculate from this reduction the concentration (EC 50) of test substance that causes 50% inhibition. The EC 50 varies with the duration of the test.

The treatment of the test substances is not described.

The number of test organisms should according to our view be limited to two species, which can be used as standard organisms in order to obtain better comparability of results.

Recovery test

SACSA 76 (9). Presented by France.

The procedure lacks information on suitable test animals and on a suitable ratio of biomass to volume of test medium.

In our view during the tests, oxygen concentrations (and sometimes pH values) should be measured and recorded.

Acute toxicity tests

SACSA 76 (10). Presented by the United Kingdom.

A suitable test duration is not mentioned. This depends, of course, on the test animal. For example, acute tests with molluscs should in general be continued for longer periods than tests with crustaceans and fishes, which cannot isolate themselves from their environment.

It is understood that a test animal is not specified since the test should be applicable to all countries who may need to use different animals to be representative of organisms in their own receiving waters. Nevertheless it might be considered to give an indication of suitable test durations for a number of frequently used test species. The duration of a test also depends on whether or not the animals are fed. Hunger might form a secondary stress factor. On the other hand, feeding introduces another variable whereas inappropriate food could be an additional stress factor too, or alternatively lead to differentiation between different species.

On page 3 it is stated that "The experiments should be continued to establish the position of the asymptotic median lethal concentration". It may, however, be impossible to achieve this in tests of short duration. On the other hand, an asymptotic median lethal concentration sometimes appears to be reached within several days, but the LC 50 vs time curve would have bent downwards if the test had been continued. Examples of this will be published in short time by TNO. In view of the foregoing, for acute tests according to our view a minimum of 7 days and a maximum of 14 days should be recommended.

Measurement of Biochemical Oxygen Demand

SACSA 76 (6). Procedure proposed by Ireland.

The procedure proposed is the standard BOD procedure, which has been extensively tested, and consequently does not need further comment. Although the point is mentioned, in our view the fact that the toxicity of a waste may strongly affect the results of a BOD determination deserves more emphasis.

Since the test was originally meant for assessing the demands made by domestic wastes on the capacity of sewage purification plant and on the efficiency of the purification process, there was no difficulty in finding adapted inocula.

However, inocula for the testing of industrial wastes are much less readily available. In most cases it is therefore necessary to obtain a BOD curve, from which it can be seen whether a stable plateau of oxygenation is reached or not.

Since BOD values are normally determined in fresh water only, they cannot be used (except as rough approximations) for the biodegradation of the same wastes in sea water. Although the differences may not be very great, more research into the matter may be needed.

Measurement of Biochemical Oxygen Demand (B.O.D.)

INTRODUCTION

The following account of the B.O.D. test has been condensed from Standard Methods for the Examination of Water and Wastewater (13th edition) published by the American Public Health Association and available from the A.P.H.A. Publication Office, 1015 Eighteenth street, N.W., Washington, D.C. 20036, U.S.A. For more complete details the reader is referred to the original text and to the bibliography appended thereto. B.O.D. test procedures published by other recognized institutions (such as Society of Analytical Chemistry) are equivalent in most respects and may be regarded as acceptable alternatives to the methodology given here.

PRINCIPLE

The test involves the use of standardized laboratory procedures to determine the relative oxygen requirements of domestic and industrial effluents and polluted waters. The dissolved-oxygen content of the liquid, with or without dilution, is determined before and after incubation for 5 days at a standard temperature, the difference giving the oxygen demand of the sample, allowance being made for the dilution, if any, that the sample received.

APPARATUS

1. 250 - 300 ml bottles with ground glass stoppers.
2. Air incubator or water bath thermostatically controlled at $20 \pm 1^{\circ}$; light must be excluded from samples

REAGENTS

- a) High quality distilled water for solution preparation and sample dilution.

b) Phosphate buffer solution.

Dissolve 8.5 g potassium dihydrogen phosphate, KH_2PO_4 , 21.75 g dipotassium hydrogen phosphate, K_2HPO_4 , 33.4 g disodium hydrogen phosphate heptahydrate, $\text{Na}_2\text{HPO}_4 \cdot 7\text{H}_2\text{O}$, and 1.7g ammonium chloride, NH_4Cl , in about 500 ml distilled water and dilute to 1 liter. The pH of this buffer should be 7.2 without further adjustment.

c) Magnesium sulphate solution

Dissolve 22.5 g $\text{MgSO}_4 \cdot 7\text{H}_2\text{O}$ in distilled water and dilute to 1 liter.

d) Calcium chloride solution

Dissolve 27.5 g anhydrous CaCl_2 in distilled water and dilute to 1 liter

e) Ferric chloride solution

Dissolve 0.25 $\text{FeCl}_3 \cdot 6\text{H}_2\text{O}$ in distilled water and dilute to 1 liter.

f) Acid and Alkali solutions, 1N.

g) Sodium Sulphite solution, 0.025 N.

Dissolve 1.575 g anhydrous Na_2SO_3 in 1 liter distilled water: This solution is not stable and should be prepared daily.

Note: Solutions b - e should be discarded if there is any sign of biological growth in the stock bottles.

SEEDING

When there is reason to believe that the sample contains very few

microorganisms - as a result, for example of chlorination, high temperature or extreme pH - the dilution water should be seeded. The standard seed material is settled domestic sewage which has been stored at 20° C for 24 - 36 hours. The standard seed concentration is 1 - 2 ml per liter of dilution water. Seeded dilution water should be used the same day it is prepared.

PROCEDURE

1. Dilution water should be saturated with dissolved oxygen and held at 20°C ± 1°C. To each liter add 1 ml of reagents b, c, d and e.

Note: Reagent b (phosphate buffer) should be withheld until the day dilution water is to be used.

2. Samples containing caustic alkalinity or acidity are neutralized to about pH 7.0 with 1N H₂SO₄ or NaOH. The pH of the seeded dilution water should not be changed by preparation of the lowest dilution of sample.

Additional pretreatment steps may be necessary where samples contain residual chlorine compounds, toxic substances or where samples are supersaturated with dissolved oxygen (refer to original text).

3. Make several dilutions of the prepared sample so as to obtain the required oxygen depletions, that is, as little dilution water as possible consistent with at least 30 per cent. of the dissolved oxygen being present at the end of the test.
 - dilution must be performed without entrainment of air, preferably by siphoning.
 - two B.O.D. bottles are filled with diluted sample at each level of dilution. One bottle is for incubation, the other for determination of the initial dissolved oxygen content of the mixture.

4. Determine initial dissolved oxygen concentrations for each dilution using an appropriate method, for example, the azide modification of the iodometric method (also described in A.P.H.A. Standard Methods for the Examination of Water and Wastewater).

5. Incubate replicate dilutions and a blank dilution water sample for 5 days at 20°C in the dark. Subsequently determine residual dissolved oxygen in each bottle using the same technique as in 4) above. Where applicable, a series of seed dilutions should be incubated to allow correction for the presence of seed material in the sample.

6. Calculation of B.O.D.

Without seeding:

$$\text{Mg/l B.O.D.} = \frac{D_1 - D_2}{P}$$

With seeding:

$$\text{Mg/l B.O.D.} = \frac{(D_1 - D_2) - (B_1 - B_2) F}{P}$$

Where

D_1	=	DO of diluted sample 15 minutes after preparation
D_2	=	DO of diluted sample after incubation
P	=	Decimal fraction of sample used
B_1	=	DO of dilution of seed control before incubation
B_2	=	DO of dilution of seed control after incubation
F	=	ratio of seed in sample to seed in control.

Paper presented by the United Kingdom

ANNEX II

CONVENTION FOR THE PREVENTION OF MARINE POLLUTION BY DUMPING FROM SHIPS AND AIRCRAFT

FOURTH MEETING OF THE STANDING ADVISORY

COMMITTEE FOR SCIENTIFIC ADVICE

NANTES, 8-10 September 1976

ACUTE TOXICITY TESTS

Introduction

There are numerous examples in the literature of "standard" toxicity tests (Alabaster and Abram 1965, APHA et al 1970, ASTM 1970, Portmann and Connor 1968 etc) and generally laboratories have adopted or modified one of these procedures to meet their requirements. Since it is likely that all countries have the experience or capability in undertaking such tests with appropriately trained scientific personnel it is not the intention of this paper to describe yet another standard method. Indeed it is considered, in establishing a toxicity test to assess the likely impact of a compound in the marine environment, that factors such as temperature and salinity and species common to the area in question are given due weight.

However it is essential that any toxicity test should fulfil certain basic minimum requirements in respect of test procedure and in the collection, analysis and reporting of results, so that the quality of the information presented can be readily evaluated. The following paragraphs therefore draw attention to important aspects of all test procedures and offer guidelines where appropriate. An example of a suitable test procedure is given in Annex I; a format for the detailed reporting of the results of a toxicity test is at Annex II.

Chemical Stability of Test Solution

Since the object of this type of toxicity test is to relate effect to exposure it follows that the concentrations of the test solutions should be maintained as constant as possible over time. This particularly important for those compounds which are rapidly degraded, absorbed by the test animals or lost by volatilisation. The most suitable technique to overcome these problems is to use a constant flow apparatus (Abram 1960, Brungs and Mount 1967, Connor and Wilson 1972, Stark 1967, and others) in which the chemical under investigation is added continuously to the test tank at such a rate as to maintain a steady level of the chemical in solution. Where it is not possible

to use a constant flow method, "static" tanks may be used, with or without aeration of the test solutions, but replacement of the solutions should be frequent enough to minimise losses of the chemical. In all cases the rates of water exchange should be sufficient to maintain high levels of dissolved oxygen in the water and to remove metabolites.

The level and stability of the test solutions should be monitored by chemical analysis for the appropriate determinand.

The chemical stability of the test solutions is dependent also on a clean and stable supply of sea water; in particular the presence of suspended material can alter the dissolved levels of chemical added. The source of the sea water and any treatment (eg filtration) should be reported.

In some instances solvents such as ethanol or acetone have been used to assist solution of relatively insoluble compounds. The use of such solvents should be avoided whenever possible. When used an appropriate control containing the solvent in sea water should be incorporated into the test schedule.

Test Animals

It has been agreed earlier that it is not possible to specify species that can be utilised in all test conditions. However in order to gain information on the relative susceptibilities of different types of animal all chemicals shall be tested using a species of Mollusc, Crustacea and fish. Additionally the tests should be carried out with (sub) adult Artemia salina since this species is available to all laboratories and may serve effectively as an internal calibrator.

The name of the test organisms should be given to the specific level.

The susceptibility of a species will vary with many physiological parameters so that a complete description of the test organisms is necessary. In particular size (length/weight), condition index, age and sex should be given where appropriate.

In most instances the test animals will be collected from field populations and all care must be exercised in their capture, transport, and maintenance. They should be hel

in test conditions for sufficient time to allow animals injured during capture to be identified and eliminated, and to allow healthy animals to acclimatise. This will usually be 2-3 days at least.

The numbers of animals per tank and per treatment (ie concentration of chemical) will depend on the size of the animals and size of tank commensurate with maintaining satisfactory levels of test compounds / dissolved oxygen. However the numbers of animals used per treatment should be sufficient to allow valid statistical treatment of the results (ie not less than 10). Similarly there should be sufficient concentrations used to produce a valid toxicity curve (not less than 5).

The responses of the test animals will vary with species and test compound so the effect used for establishing the toxicity curve should be clearly stated in all cases. This end point is usually taken as death of the individual but even here the effective response should be defined - lack of response to touch, lack of locomotor activity etc.

Feeding regimes of the test organisms should be given.

Dead animals should be removed frequently. They should be retained for residue analysis of the test compound (or possible metabolites).

Collection and Treatment of Data

Sprague (1969) has described in detail how data from toxicity tests can be manipulated. Basically a time series of observations on the percentage mortality (response) is collected for each treatment level. These observations can then be analysed on the basis of successive fixed times (quantal data) according to Litchfield and Wilcoxon (1949) or on the basis of fixed concentrations (quantitative data) according to the method of Litchfield (1949). For the purposes of the proposed tests it does not matter practically which of these two forms of data collection and analysis is used but in all cases the full statistics of each series should be given, namely the median and variance (or confidence limits).

These data should be presented in the form of a response curve relating concentration and time, and the experiment should be continued to establish the position

of the asymptotic median lethal concentration.

References

- Abram, F. S. H. (1960). An automatic dosage apparatus. *Lab. Pract.*, 9: 796-797.
- Alabaster, J. S. and F. S. H. Abram (1965). Estimating the toxicity of pesticides to fish. *PANS (C)*, 11 (2): 91-97.
- APHA/AWWA/WPCF (1971). Standard methods for the examination of water and waste water. 13th Ed. Washington D.C. 20036, USA.
- ASTM (1970). Standard method of test for evaluating acute toxicity of industrial wastes to freshwater fishes. American Society for Testing Methods, ASTM B: 1345-59.
- Brungs W. A. and D. I. Mount (1967). A device for continuous treatment of fish in holding chambers. *Trans. Amer. Fish. Soc.* 96: 55-57.
- Connor, P. M. and K. W. Wilson (1972). A continuous-flow apparatus for assessing the toxicity of substances to marine animals. *J. exp. mar. Biol. Ecol.*, 9: 209-215.
- Litchfield, J. T. (1949). A method for rapid graphic solution of time percent effect curves. *J. Pharmac. exp. Ther.*, 97: 299-408.
- Litchfield, J. T. and F. Wilcoxon (1949). A simplified method of evaluating dose-effect experiments. *J. Pharmac. exp. Ther.*, 96: 99-113.
- Portmann, J. E. and P. M. Connor (1968). The toxicity of several oil-spill removers to some species of fish and shellfish. *Mar. Biol.*, 1: 322-329.
- Sprague, J. B. (1969). Measurement of pollutant toxicity to fish. I Bioassay methods for acute toxicity. *Water Research*, 3: 793-821.
- Stark, G. T. C. (1967). An automatic dosing apparatus made with standard laboratory ware. *Lab. Pract.*, 16: 594-595.

ANNEX I

EXAMPLE OF AN APPROPRIATE TOXICITY TESTING PROCEDURE

The following is a test procedure currently used at the Fisheries Laboratory, Burnham-on-Crouch, UK. The test method involves continuous replacement of test solutions. The continuous flow apparatus is described in detail elsewhere (Connor and Wilson, 1972) so that only a brief description is given here. The apparatus was built to supply each of twenty 10-litre 'Perspex' treatment aquaria with its own flow of sea water containing the chemical at a constant concentration. Sea water (salinity 29-31 ‰) is pumped from the sea into settling tanks and then into the laboratory supply where it is filtered to 1 m μ and enters the reservoir tank where it is heated (or cooled) to 15°C (see Figure 1). Water in the tank is pumped continuously to the header tank at a rate which exceeds the demand of the aquaria, the excess sea water overflowing back into the reservoir tank. The header tank feeds the treatment aquaria individually, each separate flow passing through its own adjustable and calibrated flowmeter into the mixing chamber. The chemical, held in the storage bottle, is metred into the mixing chamber at a constant rate by a peristaltic pump. Here it mixes with the flowing sea water, and the solution thus formed leaves the chamber and flows into the treatment aquarium before running to waste. All flows are adjustable, but in the present hypothetical experiments sea water was supplied to each aquarium at 10 l/hour and stock solution at 6.67 ml/hour; the desired concentrations in the aquaria were achieved by making up stock solutions of chemical at concentrations 1500 times greater than that desired. Stock solutions were made up every 48 hours. Fifteen adult brown shrimps (Crangon crangon), body length 50-60 mm, wet weight 1.0-1.7 g, were added to each aquarium. Two aquaria were used for each concentration; two control aquaria received sea water only.

The tanks were inspected frequently and dead shrimps, ie those that did not respond when touched, were removed, measured and weighed, and deep frozen for later chemical analysis. The animals were not fed during the experiment which lasted for 2 weeks.

The water in each tank was analysed twice daily for the chemical (the details of the analytical method would normally be given here). Dissolved oxygen levels were monitored daily.

The distribution of the survival times of the shrimps at each concentration was found to be log normal (typical results are shown in Fig. 2) and the results were analysed graphically to determine the mean survival times (ET_{50}) and 95% confidence limits (Litchfield 1949). The resulting survival-concentration curve is shown in Fig. 3.

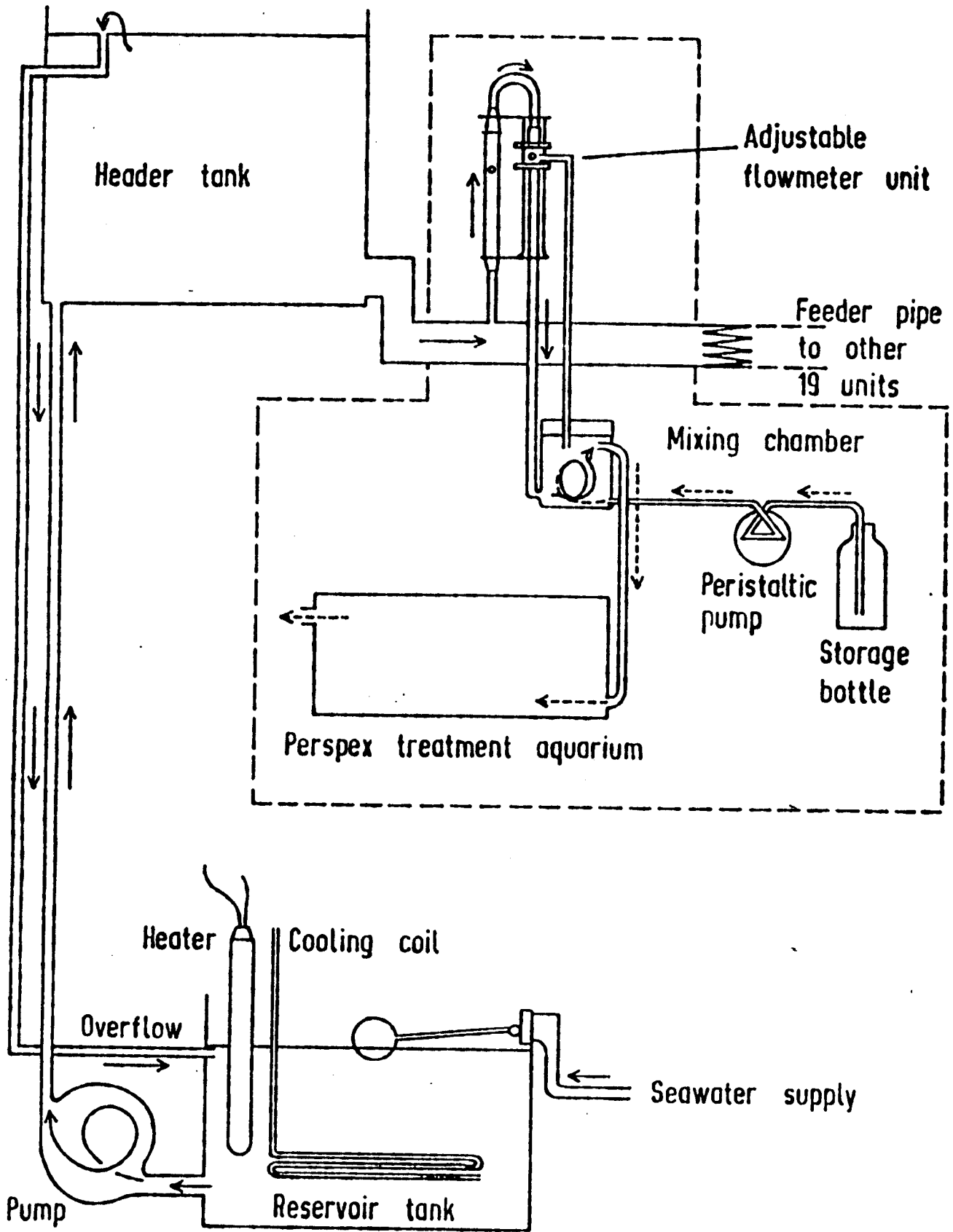

Figure 1 Diagram of the continuous flow apparatus. Only one treatment unit is shown.

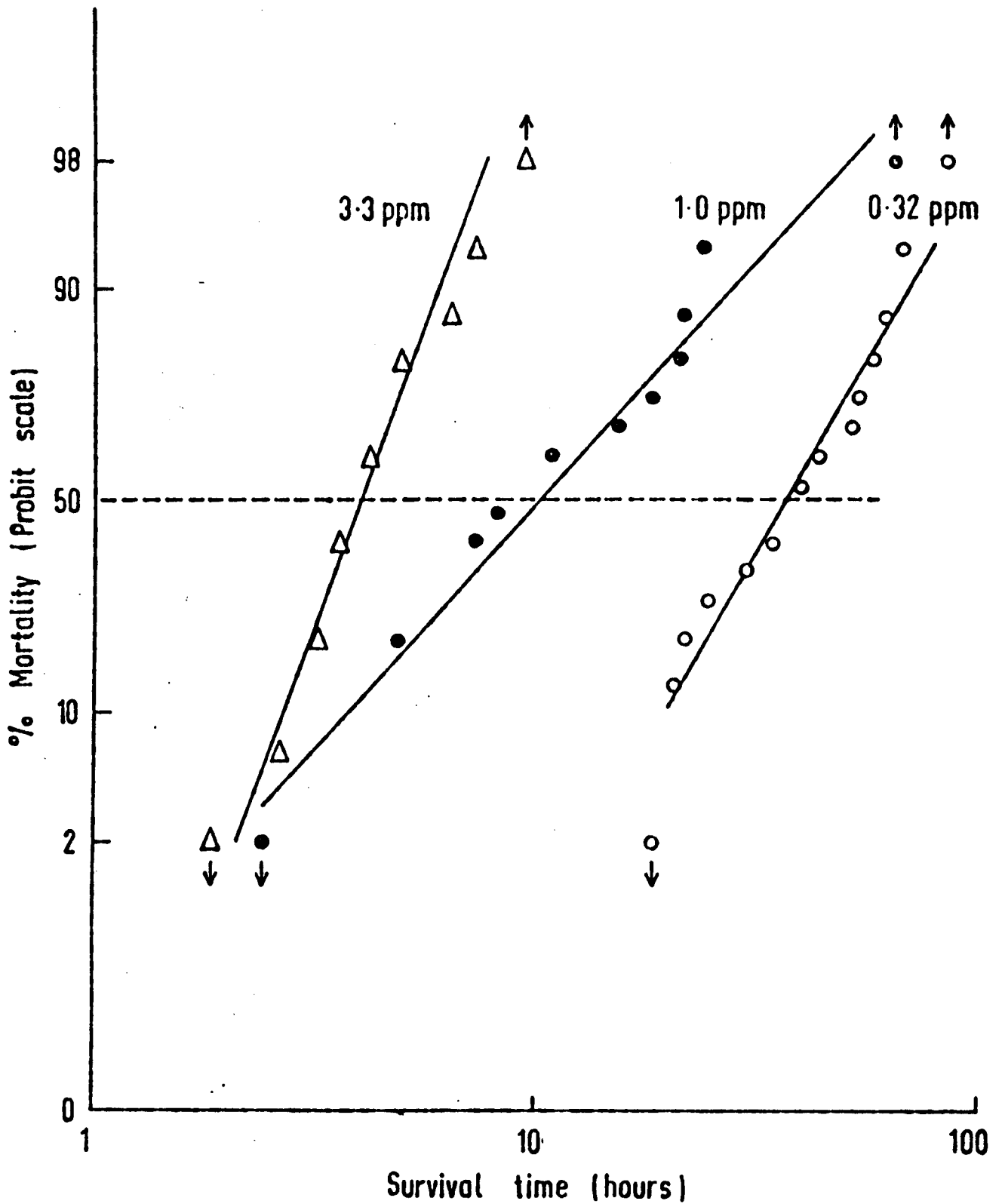

Figure 2 The accumulative percentage mortality curves for the brown shrimp. The ET₅₀ is the time that each line intersects 50 per cent mortality.

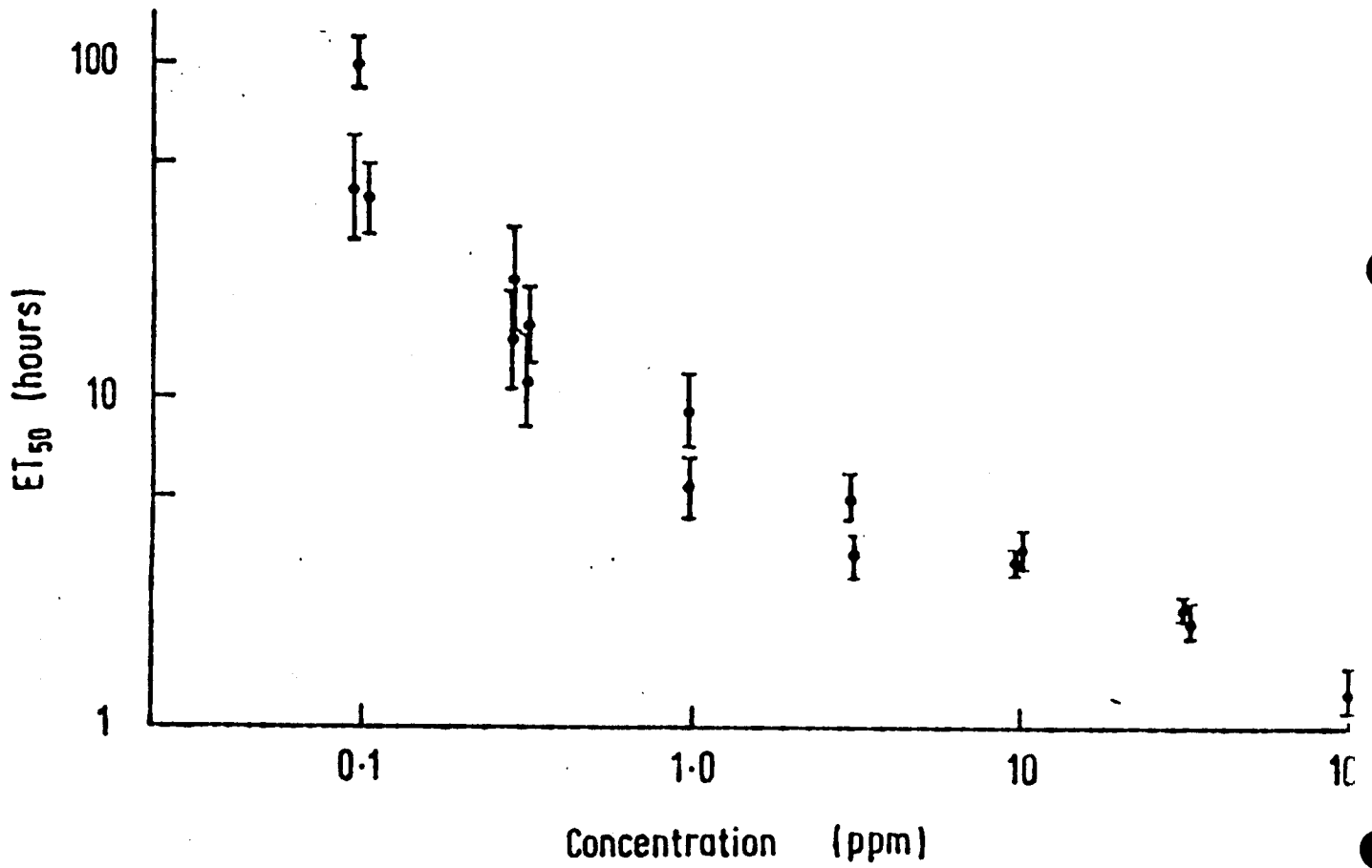

Figure 3 Survival-concentration curve for Crangon
Mean and 95 per cent confidence limits are shown for each determination.

ANNEX II : MINIMUM DETAILS REQUIRED IN PRESENTING RESULTS OF TOXICITY TESTS

A. METHOD

1. Test material - (physical and chemical description).
2. Reaction of test material with sea water (solubility, precipitation).
3. Identity and concentration of solvent used - if required.
4. Diluent sea water: origin (natural, synthetic).
 - salinity
 - temperature
 - pH
 - suspended solid load or level of filtration
5. Treatment technique (static, replacement, constant flow).
6. Material and size of tanks.
7. Replacement rate.
8. Degree of aeration.
9. Number of treatments, ie concentrations.
10. Number of replicates per treatment.
11. Species (identify to specific level, origin etc).
12. Length/weight of test animals.
13. Number of animals per tank.
14. Feeding regime.
15. Definition of effective response.

B. RESULTS

These may be presented in tabular or graphic format.

1. Median effective times (or concentrations) together with variance, slope function or confidence limits for each observation series (concentration/time).

The authority of the method should be quoted. (see item 7 regarding concentrations).
2. Relationship between concentration and time should be given, preferably as a toxicity curve.

3. Length of experiments.
4. Control mortality.
5. Mortality in those concentrations where median kills were not achieved.
6. Dissolved oxygen levels.
7. Results of analyses of water-giving actual, not nominal, concentrations.
8. Results of analyses on dead animals.

ANNEX III

Original: French

OSLO COMMISSION SECRETARIAT
STANDING ADVISORY COMMITTEE FOR
SCIENTIFIC ADVICE

FIFTH MEETING

STOCKHOLM 19-21 SEPTEMBER 1977.

TITLE: METHODOLOGY OF TESTS

PRESENTED BY: FRANCE

AGENDA ITEM: 3

SOURCE: SACSA, Nantes (76), Paragraph 15

CONVENTION FOR THE PREVENTION OF MARINE POLLUTION BY DUMPING FROM
SHIPS AND AIRCRAFT.

- METHODOLOGY OF TESTS - RECOVERY TEST
- INHIBITION OF THE GROWTH OF PHYTOPLANKTON

RECOVERY TEST

The presentation of results of the recovery test should include the following information in addition to the minimum details required for all toxicity tests.

- Exposure time

1 hr 2 hr and 4 hours seem to be the most suitable for animals that cannot isolate themselves from their environment (fish, crustacea). On the other hand, for the "filter feeding bivalves", the exposure time could be significantly increased.

- Observation time

At least 96 hours are required for the observation of lethal effects attributable to exposure times.

- Evolution curves of the concentration of major pollutants of the waste during the longest exposure time: the following results are based on the analysis carried out during the biological test.

Amount of clean sea water used during the period of observation.

- Definition of the lethal criterion.

The lack of response to touch could be considered as a lethality criterion applicable to a majority of species. Nevertheless, in regard to mussels, the lack of the byssus fixation at the end of the experiment could constitute an important part of the information.

- Expression of the results.

A table, showing the mortality thresholds would permit the assessment of the concentration limits which do not produce effects after 1, 2 and 4 hours of exposure.

Example of recovery test procedure applied at the I.S.T.P.M. Laboratories in NANTES (F).

A series of experimental baths at the appropriate concentrations is prepared with decanted natural sea water (salinity 21-30 o/oo, temperature

18°C). The mixing is effected by mechanical agitation in a stoppered glass container (2 l). After complete dissolution the mixture is poured into a glass aquarium (4 litres) without an aeration system.

Homogeneous samples of acclimatized animals, comprising 10 to 20 individuals, according to their size, are introduced and maintained in the baths for periods of 1, 2 and 4 hours, following diagram below.

		Concentrations	
		C_1	C_n
By species	0	C_1 - 1 hour	C_n - 1 hour
	control	C_1 - 2 hours	C_n - 2 hours
		C_1 - 4 hours	C_n - 4 hours

Once the exposure time has elapsed, the animals are carefully collected in a sieve, rinsed in clean sea water and placed in aquaria containing clean sea water, which is renewed at least twice a day. The behaviour of the individuals is observed and the mortalities accounted for at the end of 48 and 96 hours.

During this period the organisms can be fed as appropriate either with adult or nauplii of *Artemia salina* or with phytoplankton cultures.

The table below gives the results of tests carried out with different concentrations of DICHLORETHYLENE.

The evolution curve for concentration according to the exposure time is represented by the following table.

INHIBITION OF THE GROWTH OF PHYTOPLANKTON

The minimum of specific information from tests on the inhibition of the growth of phytoplankton required for interpretation should include:

- Chemical composition of nutritive medium
- Incubation temperature,
- The duration of the exposure time and the light intensity,
- Number of cells per volume unit present in the inoculum culture.
- Method used for the numeration of cells:
 - . coulter counter,
 - . optical density,
 - . respirometry.

D I C H L O R E T H Y L E N E :

 Civelles d'Anguilla anguilla (anguille)

		POURCENTAGES DE MORTALITE	
		48 H	96 H
78,65 mg/l	$\frac{1}{2}$ H	0	0
	1 H	0	0
	2 H	0	0
	4 H	0	0
90,75 mg/l	$\frac{1}{2}$ H	0	0
	1 H	6,4	6,4
	2 H	6,8	6,8
	4 H	28,5	28,5
102,85 mg/l	$\frac{1}{2}$ H	0	0
	1 H	33,3	33,3
	2 H	12,9	12,9
	4 H	31,0	31,0
108,9 mg/l	$\frac{1}{2}$ H	12,9	12,9
	1 H	13,7	13,7
	2 H	41,9	41,9
	4 H	90,0	90,0
121,0 mg/l	$\frac{1}{2}$ H	18,5	18,5
	1 H	25,8	25,8
	2 H	90,3	90,3
	4 H	100,0	100,0
127,05 mg/l	$\frac{1}{2}$ H	10,0	10,0
	1 H	64,5	64,5
	2 H	96,6	96,6
139,15 mg/l	$\frac{1}{2}$ H	23,3	23,3
	1 H	65,6	65,6
	2 H	100,0	100,0
151,25 mg/l	$\frac{1}{2}$ H	63,3	63,3
	1 H	79,3	79,3
	2 H	100,0	100,0

Pourcentages de mortalité, à 48 et 96 heures, pour des civelles exposées 30 mn, 1, 2 ou 4 heures à différentes concentrations de dichloréthylène.

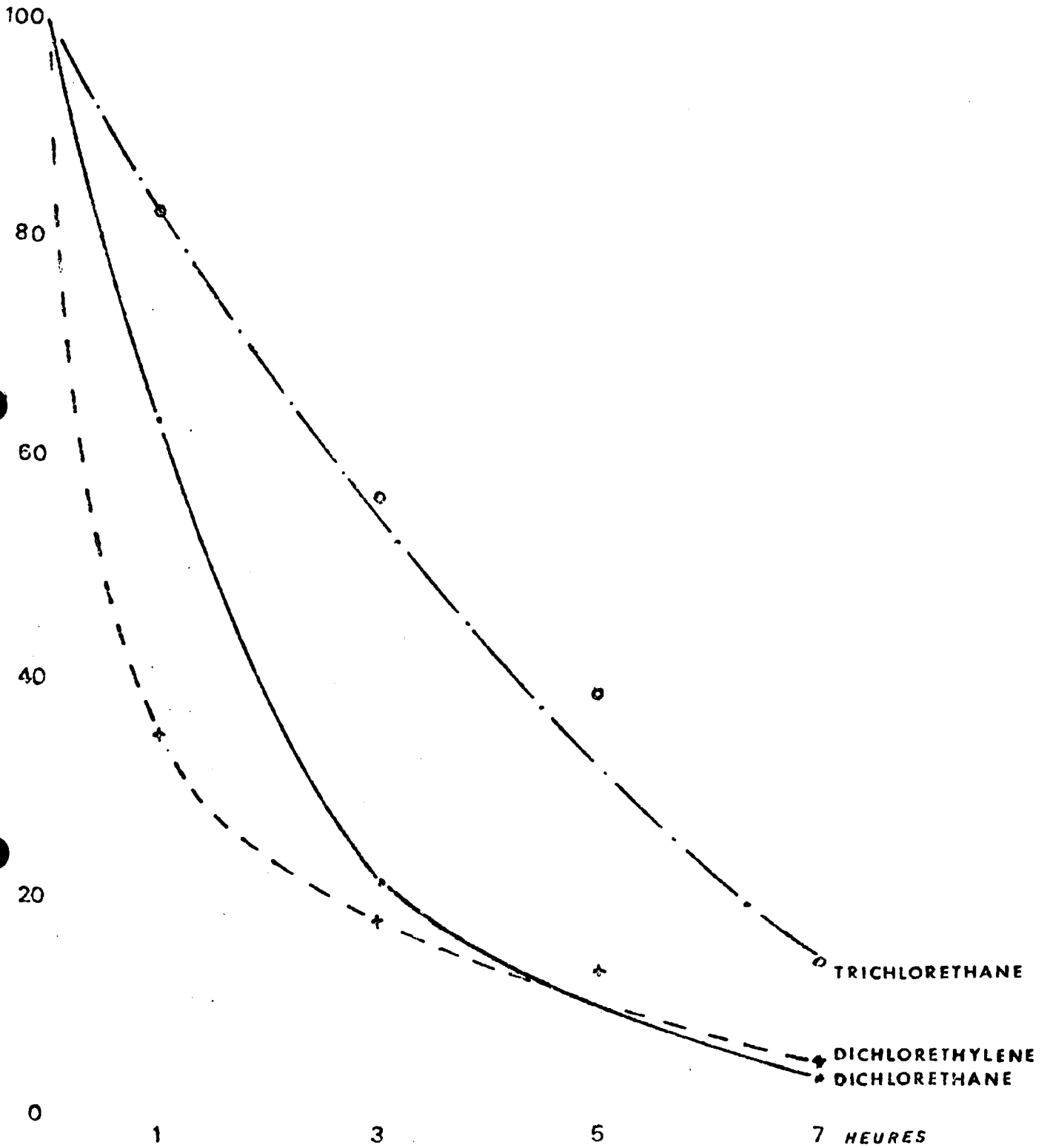

Persistence des organochlorés en eau de mer

- Conservation of strains
 - . identity of strain,
 - . transplantation medium,
 - . frequency of transplantations.
- Method used for the calculation of the inhibitions of growth.

Example of the method of operation of a test on the inhibition of the growth of phytoplankton as used in the I.S.T.P.M. Laboratories NANTES (F).

The cultures are carried out in test tubes fitted with a Cap-0-test type stopper, in a nutritive environment E.S. of PROVASOLI. Each tube is filled in succession with:

- 8,5 ml of nutritive environment
- 1 ml of a known dilution of the waste in sea water
- 0,5 ml of an inoculum containing about 10^5 cells from a pure stock in a phase of exponential growth.

The quantities of wastes introduced are calculated so that there is a series of increasing concentrations each comprising 4 to 5 control tubes and at least 3 tubes per concentration so as to establish a growth mean.

The cultures are incubated at $18 \pm 1^\circ\text{C}$ and illuminated 12 hours out of 24 at an intensity greater than 2000 Lux. In order to limit the natural sedimentation of the benthic algae, it is necessary to agitate the tubes regularly.

The cellular growth is followed daily either by counting the cells under a microscope or a "Coulter counter" or by measuring the optical density of the culture.

Test Species

The phytoplankton species which lend themselves most easily to being cultured in an artificial medium are generally diatomae or flagellates. As a guide the following species can be considered as the most frequently used:

- diatomae : Gyrosigma spencerii, Phaedoactylum tricorutum
Skeletonema costatum
- flagellates : Dunaliella tertiolecta, Isochrysis galbana,
Monochrysis lutheri, Tetraselmis suecica

The stocks are kept in a sterile environment and maintained by successive transplantation at least twice a month.

The medium E.S. of PROVASOLI is prepared from 4 solutions, the chemical composition of which is as follows:

SOLUTION I

Fe (NH ₄) ₂ (SO ₄) ₂ , 6 H ₂ O	7,020 g
Na ₂ EDTA	6,600 g
H ₂ O QSP	1 1

SOLUTION II

H ₃ BO ₃	11,400 g
Fe Cl ₃ , 6 H ₂ O	0,490 g
Mn SO ₄ H ₂ O	1,640 g
Zn SO ₄ 7 H ₂ O	0,220 g
Co SO ₄ 7 H ₂ O	0,048 g
Na ₂ EDTA	10,000 g
H ₂ O QSP	1 1

SOLUTION III

Metasilicate de sodium NaSiO ₃ , 5 H ₂ O	100 mg
Eau distillee QSP	1 1

SOLUTION IV

NaNO ₃	70,000 g
Na ₂ Glycerophosphate	10,000 g
Solution I	500 ml
Solution II	500 ml
Solution III	2 ml
Vitamin B ₁₂	0,002 g
Thiamine	0,100 g
Biotine	0,001 g
TRIS	100,000 g
H ₂ O QSP	2 1

The pH value is adjusted to 7.8 with fuming HCL.

The definitive culture medium is obtained by adding 2 ml of solution IV to one litre of sea water and sterilized by autoclave at 120°C for 30 minutes.

Expression of the results

The growth curve is established point by point until the end of the exponential phase (Annex I). This serves as a basis for determining the inhibition, which is expressed as a growth percentage in relation to the controls.

The curve giving the growth percentage in relation to the controls in terms of the concentration in waste allows the graphical determination of the concentration which causes a 50 per cent reduction in normal growth.

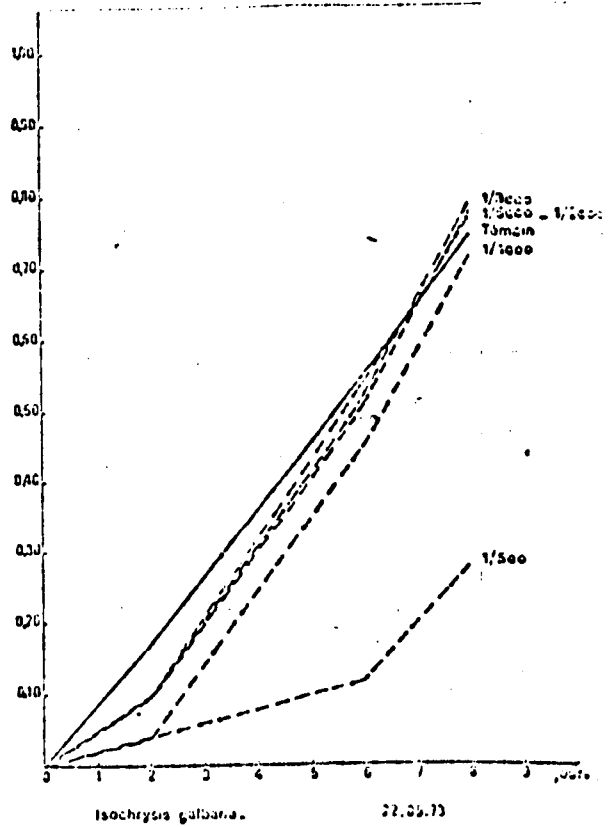
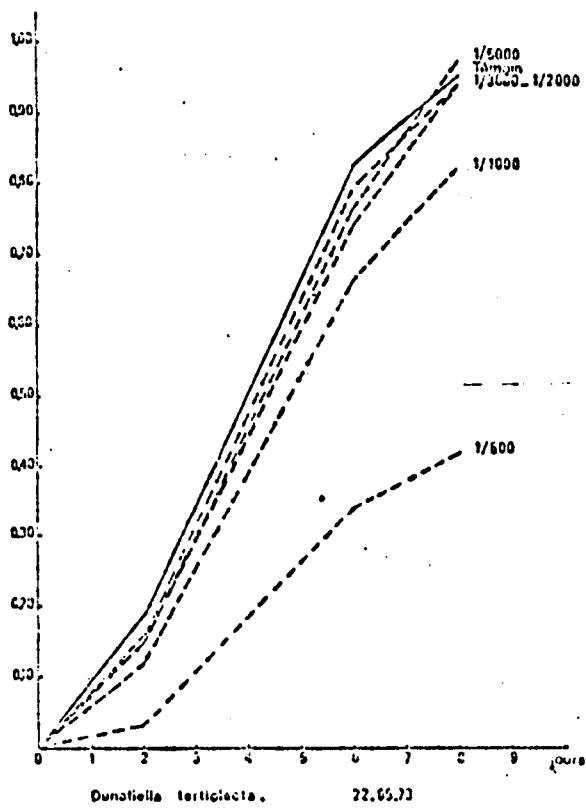
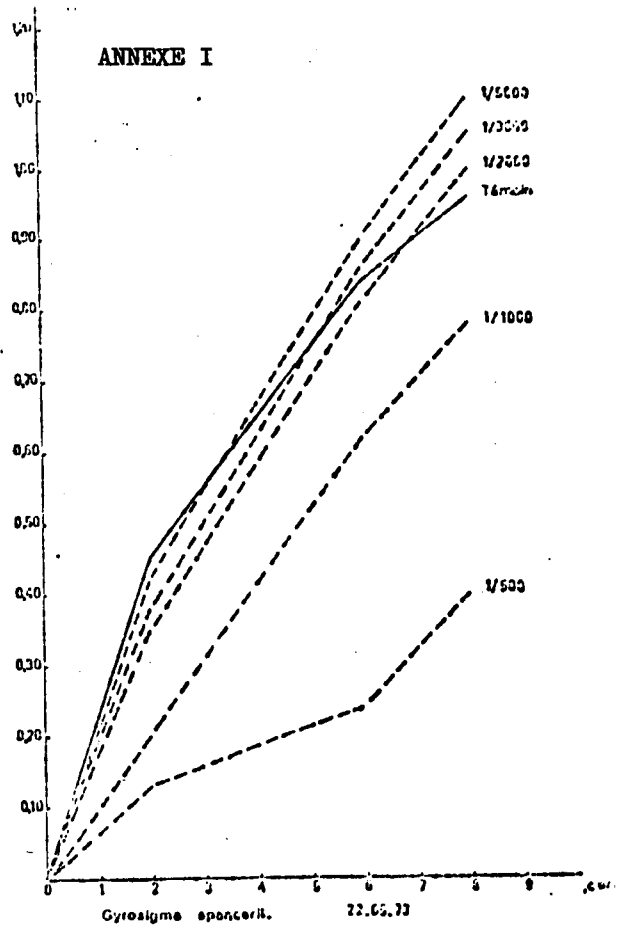
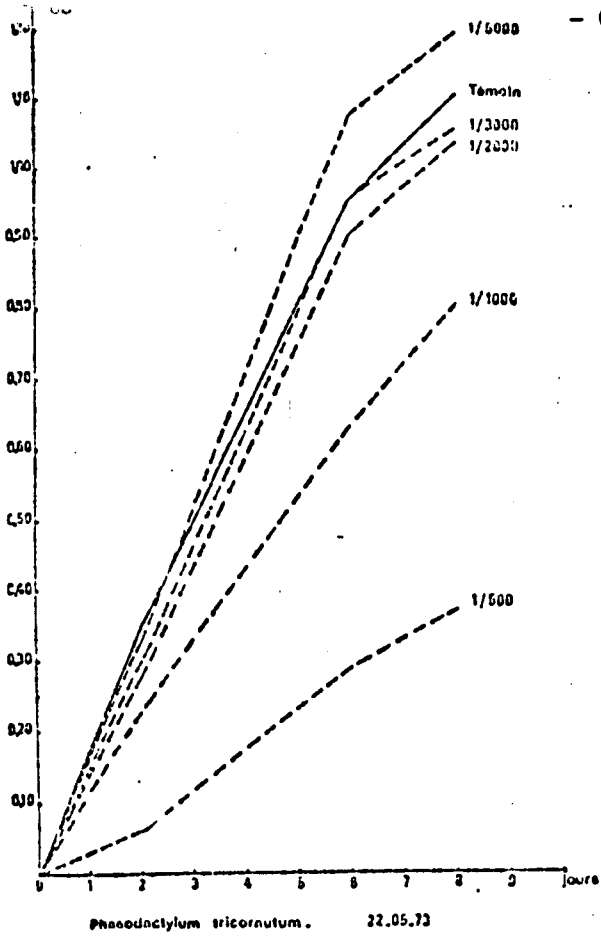

Courbes de croissance de 4 espèces phytoplanctoniques en présence de différentes dilutions d'un effluent industriel.

ANNEX II

Bibliography

ALZIEU (Cl.), 1972. - Toxicité relative de produits antipétrole sur deux organismes marins. - Rev. Trav. Inst. Pêches Marit., 36(1), p. 103 - 109.

LACAZE (J.C.), 1969. - Effets d'une pollution du type "Torrey Canyon" sur l'algue unicellulaire marine Phaeodactylum tricornutum. - Rev. Intern. Oceanogr. med., 13-14, p. 157 - 179.

LASSUS (P.), 1974. - Etude de la toxicité de solutions acides de sels de fer sur le plancton marin. - Thèse de doctorat 3ème cycle. Marseille.

PROVASOLI (L.), Mc LAUGHLIN (J.) et DROOP (M.), 1957.. - The development in artificial media for marine algae. - Arch. microbiol., 12 (3), p. 392 - 428.

ANNEX III

Ministry of Agriculture, Fisheries and Food

Our ref BLR 1640

Fisheries Laboratory
Remembrance Avenue
Burnham-on-Crouch
Essex
England
CMO 8HA

Mr. N.J. Spijker
Rijkswaterstaat
Directie noordzee
Nijverheidsstraat 1
Rijswijk (z.h.)
The Netherlands

4 September

Dear Mr. Spijker,

Thank you for your letter of 18 August, 1978 commenting on SACSA 76 (10) which was submitted by the United Kingdom for use under the Oslo Commission's "Prior Consultation Procedures".

On the question of whether the paper should specify a test duration, and if so, what period should be used, we still believe (as in SACSA 76 (10)) that the overriding criterion is to establish the position of the asymptotic median lethal concentration. It is our experience that, in most cases, a realistic threshold can be determined in a test of 4-6 days duration, avoiding the complicating factors associated with starvation or feeding that you point out are present in longer tests. However, where this threshold of acute toxicity is not reached with such a test, it will be necessary under the requirements of SACSA 76 (10) to extend the test to the 7-14 days you propose. We believe, however, that it would be inappropriate to specify this longer period of 7-14 days for all substances and test species, and would refer to retain the flexibility inherent in SACSA (76) (10) which allows the test duration to be decided in the light of the particular circumstances necessary.

We therefore envisage that all substances would first be tested over 4-6 days using unfed animals. Where a satisfactory median lethal threshold is not obtained by this means, a new test, making provisions for the maintenance and feeding of test organisms for an extended, but indefinite period, would be carried out until this threshold is established.

I have copied this letter to Dik Tromp.

Yours sincerely

M. G. Norton

CONVENTION POUR LA PREVENTION DE LA POLLUTION MARINE PAR LES OPERATIONS
D'IMMERSION EFFECTUEES PAR LES NAVIRES ET AERONEFS

SIXIEME REUNION DU COMITE CONSULTATIF PERMANENT DE CONSEIL SCIENTIFIQUE
COPENHAGUE : 19 - 22 SEPTEMBRE 1978

METHODOLOGIE DES EXPERIENCES RELATIVES A LA PROCEDURE DE CONSULTATION
PREALABLE

1. Lors de la Cinquième Réunion du CCPCS, la délégation française a présenté une version révisée des descriptions des expériences suivantes :
 - (a) expérience de récupération
 - (b) inhibition de la croissance du phytoplancton.
2. Des commentaires ont été reçus des Pays-Bas depuis lors.
3. Les Pays-Bas ont aussi soumis leurs commentaires sur les expériences de DBO présentées par l'Irlande (SACSA 76 (6)), et les expériences de toxicité aiguë présentées par le Royaume-Uni (SACSA 76 (10)).
4. Le Royaume-Uni a répondu aux commentaires des Pays-Bas.
5. Ci-joints les commentaires des Pays-Bas auxquels sont annexées les descriptions des expériences ainsi que la réponse du Royaume-Uni.

CONVENTION POUR LA PREVENTION DE LA POLLUTION MARINE PAR LES OPERATIONS
D'IMMERSION EFFECTUEES PAR LES NAVIRES ET AERONEFS

SIXIEME REUNION DU COMITE CONSULTATIF PERMANENT DE CONSEIL SCIENTIFIQUE

COPENHAGUE : 19 - 22 SEPTEMBRE 1978

Méthodologie des essais (croissance du phytoplancton)

SACSA 77 (19). Présenté par la France.

Cet essai a trait à l'inhibition de la croissance du phytoplancton, et il est identique dans son principe à la plupart des méthodes ayant fait l'objet d'une publication quant à ce type d'essais.

Généralités

La liste générale des critères employés dans cet essai n'indique pas le pH du médium, non plus que les modifications que ce pH est susceptible de subir pendant l'essai. La toxicité des acides faibles dépend beaucoup du pH.

Points particuliers

La méthode d'essai que l'on donne comme exemple ne décrit ni la manière dont les organismes sont élevés, conservés et manipulés, ni comment les inocula sont préparés à partir de ces organismes (dilution ? centrifugation ?).

La signification de l'expression " cellules provenant d'un stock pur " n'est pas claire. Signifie-t-elle que les cultures sont dépourvues de bactéries, ou qu'elles doivent être manipulées d'une manière aseptique ?

Nous ne sommes pas sûrs si la " température d'incubation " désigne la température dans les éprouvettes ou celle de la salle à température constante. Suivant la méthode d'essai, la première peut dépasser la seconde de plusieurs degrés. Le type de source lumineuse n'est pas indiqué, et l'on ne signale pas non plus si toutes les éprouvettes doivent être exposées à la même intensité lumineuse. Est-il nécessaire de faire incuber un organisme sous un régime

jour/nuit ? Des résultats obtenus aux Pays-Bas indiquent que dans les expériences de toxicité, le fait que les cultures soient incubées sous lumière continue ou sous lumière intermittente n'a que peu d'importance.

Au début de chaque expérience, la concentration des cellules d'algues est telle que l'on peut facilement les compter dans un compteur de Coulter. Est-il toutefois possible de mesurer directement la densité optique des cultures ? La signification de " TRIS " (composant de la solution IV) n'est pas claire. Quels sont les effets de la stérilisation à la chaleur sur le médium eau de mer ? Le pH reste-t-il constant, et des précipités sont-ils formés ? Pourquoi ne pas stériliser par filtration ? Il faudrait donner une méthode de calcul de la cadence de développement ainsi que le point d'inhibition à 50 %.

Il manque aussi une indication du nombre de dilutions nécessaires au calcul de l'inhibition du développement à 50 %.

Une alternative consisterait à donner la réduction du nombre total de cellules dans un délai donné, et, à partir de cette réduction, à calculer la concentration (EC 50) de substance test provoquant une inhibition de 50 %. L'EC 50 varie avec la durée de l'expérience. Le traitement des substances test n'est pas décrit. Le nombre d'organismes tests devrait, à notre avis, être limité à deux espèces, pouvant être employées comme organismes standard de manière à obtenir une meilleure comparabilité des résultats.

Test de récupération

SACSA 76 (9). Présenté par la France.

La méthode manque de renseignements sur les animaux adaptés à cette expérience, ainsi que sur un rapport-adéquat entre biomasse et volume de médium d'essai. A notre avis, pendant les essais, les concentrations en oxygène (et parfois les valeurs du pH) devraient être mesurées et notées.

Essais de toxicité aiguë

SACSA 76 (10). Présenté par le Royaume-Uni.

Il n'est pas mentionné de durée adéquate. Bien entendu, celle-ci dépend de l'animal cobaye. Par exemple, les expériences de toxicité aiguë effectuées sur des mollusques doivent en général se prolonger sur des périodes plus longues que les expériences sur les crustacés et les poissons, ceux-ci ne pouvant en effet s'isoler de leur milieu ambiant. D'après ce que nous comprenons, aucun animal cobaye n'est précisé du fait que l'expérience doit s'appliquer à tous les pays et que ceux-ci sont susceptibles d'employer des animaux différents et devant être représentatifs de leurs propres eaux réceptrices. On pourrait néanmoins envisager de donner une indication des durées convenant à ces expériences pour un certain nombre d'espèces fréquemment utilisées à cette fin. La durée d'une expérience dépend aussi du fait que les cobayes sont nourris ou non. La faim est susceptible de constituer un facteur secondaire de stress. A l'inverse, l'alimentation apporte une nouvelle variable et un aliment inapproprié peut former un facteur additionnel de stress, ou au contraire aboutir à des différenciations entre espèces.

On indique en page 3 que " Les expériences doivent se prolonger jusqu'à détermination de la concentration létale asymptotique médiane ". Il est peut être néanmoins possible d'obtenir cette concentration dans des expériences de courte durée. D'un autre côté, une concentration létale asymptotique médiane semblerait parfois être atteinte en quelques jours, mais la courbe de concentration létale à 50 % / temps commencerait à s'infléchir vers le bas si l'expérience se prolongeait plus avant. Le TNO publiera à bref délai des exemples sur ceci.

A notre avis, compte-tenu de ce qui précède, il faudrait recommander un minimum de 7 jours et un maximum de 14 jours pour les expériences de toxicité aiguë.

Mesure de la demande biochimique en oxygène

CCPCS 76 (6). Méthode proposée par l'Irlande.

La méthode que nous proposons est la méthode normale des DCO, qui a fait l'objet d'essais approfondis, et sur laquelle il n'est donc pas besoin de revenir. Bien que ceci soit mentionné, à notre avis, le fait que la toxicité d'un déchet puisse avoir une forte influence sur les résultats d'une détermination de la DCO devrait être mieux souligné.

Etant donné le but initial de l'expérience d'évaluer la demande des déchets domestiques sur la capacité des installations de traitement des eaux d'égoûts et sur l'efficacité du procédé de purification, il n'a pas été difficile de trouver des inocules adaptées à cet effet.

Toutefois, les inocules destinées aux tests effectués sur les déchets industriels sont beaucoup plus rares. Dans la plupart des cas, il est donc nécessaire de tracer une courbe de DCO à partir de laquelle il est possible de savoir si on a atteint un plateau d'oxygénation stable.

Etant donné que les valeurs de DCO ne sont normalement déterminées qu'en eau douce, elles ne peuvent être employées (excepté en tant qu'approximations grossières) pour la biodégradation des mêmes déchets plongés dans l'eau de mer. Bien que les différences puissent ne pas être très fortes, il est peut être nécessaire de procéder à des recherches plus approfondies sur cette question.

Irlande

ANNEXE I

Calculs des Besoins Biochimiques en Oxygène
(Biochemical Oxygen Demand - B.O.D.)

INTRODUCTION

La relation suivante du test B.O.D. est un précis du document "Standard Methods for the Examination of Water and Wastewater" (Méthodes Normales d'Examen des Eaux et Eaux Résiduelles) 13e Edition, édité par l'American Public Health Association, et que l'on peut se procurer auprès de l'A.P.H.A., Publication Office, 1015 Eighteen Street, N.W. Washington D.C. 20036, E.-U. Si le lecteur veut des détails plus complets, qu'il veuille bien se reporter au texte original et à la bibliographie qui s'y rattache. Les protocoles analytiques B.O.D. édités par d'autres organismes agréés (comme par exemple la Society of Analytical Chemistry) sont analogues à peu de détails près et à ce titre, il est possible de les considérer comme alternatives valables susceptibles de remplacer la méthodologie citée ici.

PRINCIPE

Le test exige l'emploi de méthodes de laboratoire normalisées susceptibles de déterminer les besoins relatifs en oxygène des effluents menagers et industriels, et des eaux polluées. La teneur en oxygène dissous du liquide, avec ou sans dilution, est calculée avant et après une incubation de 5 jours à une température standard, la différence donnant le besoin en oxygène de l'échantillon, compte tenu d'une dilution, le cas échéant, à laquelle l'échantillon aura été soumis.

APPAREIL

1. Flacons de 250 - 300ml, avec bouchons rodés.
2. Etuve à incubation ou bain-marie à thermostat réglé sur $20^{\circ} \text{C} \pm 1^{\circ}$; ne pas exposer les échantillons à la lumière.

REACTIFS

- a) Eau distillée d'extrême pureté pour la préparation des solutions et la dilution des échantillons.
- b) Solution-tampon de phosphate. - Dissoudre 0,5 g. de phosphate mono-potassique KH_2PO_4 , 21,75 g. de phosphate dipotassique K_2HPO_4 , 33,2 g. phosphate disodique heptahydraté $\text{Na}_2\text{HPO}_4 \cdot 7\text{H}_2\text{O}$, et 1,7 g. de chlorure d'ammonium NH_4Cl , dans 500 ml environ d'eau distillée, et diluer jusqu'à 1 litre. Le pH de cette solution-tampon doit être 7,2, sans aucune modification.

- c) Solution de sulfate de magnésium
Dissoudre 22,5 g. de $MgSO_4 \cdot 7H_2O$ dans de l'eau distillée,
et diluer jusqu'à 1 litre.
- d) Solution de chlorure de calcium
Dissoudre 27,5 g. de $CaCl_2$ anhydre dans de l'eau distillée
et diluer jusqu'à 1 litre.
- e) Solution de chlorure ferrique
Dissoudre 0,25 g. (? the text does not specify) de $FeCl_3 \cdot 6H_2O$
dans de l'eau distillée et diluer jusqu'à 1 litre.
- f) Solutions acides et alcalines, 1N.
- g) Solution de sulfite de sodium, 0,025 N.
Dissoudre 1,575 g. de Na_2SO_3 anhydre dans 1 litre d'eau
distillée. Cette solution n'est pas stable et doit être
préparée tous les jours.

N.B. Les solutions b-e doivent être jetées si l'on relève le
moindre signe de croissance biologique dans les solutions mères.

ENSEMENCEMENT

Quand on a toute raison de croire que l'échantillon contient
très peu de micro-organismes, par exemple par suite d'une chlora-
tion, de températures élevées ou d'un pH extrême, l'eau de dilu-
tion doit êtreensemencée. La matière d'ensemencement normalement
utilisée pour ce faire est de l'eau résiduelle ménagère décantée
et maintenue à 20° C. pendant 24 à 36 heures. La concentration
normale d'ensemencement est de 1-2 ml par litre d'eau de dilu-
tion. L'eau de dilution ainsiensemencée doit être utilisée le
jour même de la préparation.

METHODE

1. L'eau de dilution doit être saturée d'oxygène dissous et
maintenue à 20° C \pm 1° C. Ajouter 1 ml des réactifs b, c,
d et e par litre.
N.B. On n'ajoute pas le réactif b (solution-tampon de
phosphate) jusqu'au jour où l'eau de dilution sera
utilisée.
2. Les échantillons présentant des signes d'alcalinité caus-
tique ou d'acidité seront neutralisés pour obtenir un pH
d'environ 7.0 à l'aide de 1N H_2SO_4 , ou de NaOH. Le pH de
l'eau de dilutionensemencée ne doit pas être modifié en
préparant la dilution la plus faible de l'échantillon.

Il se peut que d'autres traitements préliminaires soient
nécessaires si les échantillons contiennent des composés
résiduels chlorés, des substances toxiques ou s'ils sont
sursaturés d'oxygène dissous (Cf le texte original).

3. Faire plusieurs dilutions de l'échantillon ainsi préparé afin d'obtenir les appauvrissements requis en oxygène, à savoir, aussi peu d'eau de dilution que possible compte tenu du fait qu'il faut en fin d'expérience qu'il y ait au moins 30% d'oxygène dissous.
 - la dilution doit être exécutée sans entraînement d'air, de préférence en siphonnant.
 - deux flacons BOD sont remplis d'échantillon dilué, pour chaque niveau de dilution. Un flacon servira à l'incubation, l'autre pour déterminer la teneur initiale en oxygène dissous du mélange.
4. Calculer les concentrations initiales d'oxygène dissous pour chaque dilution en utilisant une méthode appropriée, p.e. la modification azide de la méthode iodométrique (décrite également dans la publication A.P.H.A. "Standard Methods for the Examination of Water and Wastewater").
5. Faire incuber les dilutions parallèles et un échantillon d'eau de dilution en blanc pendant 5 jours à 20° C. dans l'obscurité. Ultérieurement calculer l'oxygène résiduel dissous en chaque flacon au moyen de la technique décrite en 4. Lorsqu'applicable, le faire incuber une série de dilutions de la matière d'ensemencement afin d'appliquer une correction pour la présence de produits d'ensemencement dans l'échantillon.

6. Calcul de BOD.

Sans ensemencement :

$$\text{Mg/l BOD} = \frac{D_1 - D_2}{P}$$

Avec ensemencement :

$$\text{Mg/l BOD} = \frac{(D_1 - D_2) - (B_1 - B_2) F}{P}$$

- Quand
- D_1 = DO de l'échantillon diluée 15 minutes après la préparation
 - D_2 = DO de l'échantillon diluée après l'incubation
 - P = Fraction décimale de l'échantillon utilisé
 - B_1 = DO de la dilution du témoin d'ensemencement avant l'incubation
 - B_2 = DO de la dilution du témoin d'ensemencement après l'incubation
 - F = Rapport matière d'ensemencement dans l'échantillon dans le témoin.

DO = oxygène dissous.

ANNEXE II

Mémoire présenté par le Royaume-Uni

CONVENTION POUR LA PREVENTION DE LA POLLUTION MARINE PAR LES OPERATIONS
D'IMMERSION EFFECTUEES PAR LES NAVIRES ET LES AERONEFS

QUATRIEME REUNION DU COMITE CONSULTATIF PERMANENT SUR CONSEILS SCIENTIFIQUES

Nantes, 8 - 10 septembre 1976

INTRODUCTION

Il existe de nombreux exemples d'examens "courants" de toxicité dans les écrits sur ce sujet (Alabaster and Abram 1965, APHA et Al 1970, ASTM 1970, Portmann and Connor 1968, etc.) et généralement les laboratoires ont adopté ou modifié l'une de ces procédures selon leurs besoins. Puisqu'il est probable que tous les pays ont l'expérience ou la capacité pour entreprendre de tels examens avec un personnel scientifique qualifié, ce mémoire n'a pas pour but de décrire une autre méthode courante. En fait, quand on prépare un examen de toxicité pour établir l'impact d'un composé sur l'environnement marin, il est considéré que des facteurs tels que la température, la salinité, et les espèces communes de la région en question sont convenablement pris en ligne de compte.

Toutefois il est essentiel que tout examen de toxicité satisfasse un minimum de conditions requises quant à la procédure suivie et le recueil, l'analyse et le rapport des résultats de manière à ce que la qualité des renseignements présentés puisse être facilement évaluée. Par conséquent, les paragraphes suivants attirent l'attention sur les points importants de toutes les procédures d'examen et suggèrent des conseils aux passages appropriés. On trouvera un exemple de procédure d'examen convenable dans l'Annexe I; et un modèle de rapport détaillé des résultats d'un examen de toxicité dans l'Annexe II.

Stabilité chimique de la Solution Utilisée pour l'examen

Etant donné que l'objet de ce genre d'examen de toxicité est d'établir le rapport entre l'effet et l'exposition, il s'ensuit que les solutions doivent être maintenues à une concentration aussi constante que possible tout au long de l'examen. Ceci est particulièrement important pour les composés qui se dégradent rapidement, qui sont absorbés par les animaux ou perdus par volatilisation. La technique qui convient le mieux pour surmonter ces problèmes est l'utilisation d'un appareil à écoulement continu (Abram 1960,

Brungs and Mount 1967, Connor and Wilson 1972, Stark 1967, et d'autres) dans lequel la substance chimique examinée est continuellement ajoutée dans la cuve d'essai dans des proportions telles que le niveau de la substance chimique est maintenu constant dans la solution. Quand il n'est pas possible d'utiliser la méthode de l'écoulement continu, on peut utiliser des cuves "statiques", avec ou sans aération des solutions, mais le remplacement des solutions doit être fréquent pour minimiser les pertes de la substance chimique. Dans tous les cas, les fréquences de changement d'eau doivent être suffisantes pour maintenir un niveau élevé d'oxygène dissous dans l'eau et pour évacuer les métabolites.

Le niveau et la stabilité des solutions utilisées doit être contrôlé par analyse chimique pour vérifier les déterminants appropriés.

La stabilité chimique de la solution dépend également d'une alimentation propre et stable d'eau de mer; en particulier la présence de matières en suspension peut changer le niveau de dissolution de la substance chimique ajoutée. La source de l'eau de mer et tout traitement doivent figurer sur le rapport, (par ex. traitement par filtrage).

Dans certains cas, des solvants comme l'éthanol ou l'acétone sont utilisés pour aider la dissolution de composés relativement insolubles. L'utilisation de ces solvants doit autant que possible être évitée. Quand ils sont utilisés, un système de contrôle contenant le solvant dans l'eau de mer doit être incorporé dans la procédure de l'examen.

Animaux utilisés pour l'examen

On a convenu plus haut qu'il n'est pas possible de spécifier des espèces susceptibles de convenir à toutes les conditions d'examen. Toutefois, dans le but d'obtenir des renseignements sur les susceptibilités relatives de différents types d'animaux, tous les produits chimiques seront examinés en utilisant une espèce de mollusques, de crustacés et de poissons. De plus, tous les examens doivent être faits en utilisant l'*Artemia salina* (sub) adulte, puisque cette espèce peut facilement être obtenue par tous les laboratoires et peut effectivement servir de calibre interne.

Le nom des organismes utilisés doit être donné au niveau spécifique.

La susceptibilité d'une espèce variera avec les nombreux paramètres physiologiques et une description complète de l'organisme d'examen est nécessaire. En particulier, la taille (longueur/poids), condition, age et sexe doivent être donnés dans les cas appropriés.

Dans la plupart des cas les animaux utilisés pour l'expérience seront recueillis sur les lieux et leur capture, leur transport et leur entretien doivent être très soigneusement effectués. Ils doivent être maintenus dans les conditions de l'expérience pendant suffisamment longtemps pour permettre l'identification et l'élimination des animaux blessés pendant leur capture

et l'acclimatation des animaux sains. Il faut compter deux à trois jours pour ceci.

Les nombres d'animaux par cuves et par traitement (c'est-à-dire concentration de produit chimique) dépendra de la taille des animaux et de celle de la cuve proportionnellement au maintien de niveaux satisfaisants de composés, oxygène dissous. Toutefois le nombre d'animaux utilisés par traitement doit être suffisant pour permettre un traitement statistique valable des résultats (c'est-à-dire supérieur à 10). De la même manière la concentration utilisée doit être suffisante pour établir une courbe de toxicité valable (pas moins de 5).

Les réactions des animaux varieront selon les espèces et le composé utilisé dans l'expérience et par conséquent l'effet utilisé pour établir la courbe de toxicité doit être clairement spécifié dans tous les cas. Cette limite est en général la mort de l'individu mais même ici la réaction effective doit être définie - pas de réaction au toucher, pas d'activité locomotrice etc.

Les régimes d'alimentation des organismes utilisés pour l'expérience doivent être donnés.

Les animaux morts doivent être enlevés fréquemment. Ils doivent être conservés pour l'analyse résiduelle du composé de l'expérience (ou éventuels métabolites).

Recueil et traitement des données

Sprague (1969) a décrit en détail comment les données d'examen de toxicité doivent être traitées. Fondamentalement, une série d'observations effectuées à intervalles réguliers sur le pourcentage de mortalité (réaction) est recueillie à chaque stage de traitement. Ces observations peuvent ensuite être analysées sur la base de temps successifs fixes (données quantales) d'après Litchfield et Wilcoxon (1949) ou sur la base de concentration fixes (données quantitatives) selon la méthode de Litchfield (1949). Dans le cas des examens proposés l'une ou l'autre de ces méthodes peut être utilisée pour le recueil et l'analyse des données mais dans tous les cas les statistiques complètes de chaque série doivent être consignées, à savoir moyenne et variante (ou limites de confiance).

Ces données doivent être présentées sous forme d'une courbe de réaction établissant le rapport de la concentration moyenne mortelle asymptotique.

Références

- Abram, F.S.H. (1960). An automatic dosage apparatus. Lab. Pract., 2: 767-767. (dispositif de dosage automatique)
- Alabaster, J.S. and F.S.H. Abram (1965). Estimating the toxicity of pesticides to fish. PANS (C), 11 (2) : 91-97. (évaluation de la toxicité des pesticides chez les poissons)

- APHA/AWWA/WPCF(1971) Standard methods for the examination of water and waste water. 13th ed. Washington D.C. 20036, USA.
(méthodes standard pour l'examen de l'eau et eaux usées).
- ASTM (1970). Standard method of test for evaluating the toxicity of industrial wastes to freshwater fishes. American Society for Testing Methods, ASTM B: 1345-59.
(méthodes pour l'évaluation de la toxicité des déchets industriels chez les poissons d'eau douce)
- Brungs W.A. and D.I.Mount (1967). A device for continuous treatment of fish in holding chambers. Trans. americ. Fish. Soc. 96 : 55-57.
(dispositif pour traitement continu des poissons)
- Connor P.M. and K.W.Wilson (1972). A continuous-flow apparatus for assessing the toxicity of substances to marine animals. J. exp. mar. Biol. Ecol., 2: 209-215.
(système à écoulement continu)
- Litchfield J.T.,(1949). A method for rapid graphic solution of time per cent effect curves. J. Pharmac. exp. Ther., 97 : 299-408.
(méthode pour une solution rapide des courbes d'effet/ pourcentage-temps.)
- Litchfield, J.T. and P.Wilcoxon (1949). A simplified method of evaluating dose-effect experiments. J.Pharmac. exp. Ther., 96: 99-113.
(méthode simplifiée pour l'évaluation des expériences dose-effets.)
- Portmann, J.E. and P.M.Connor (1968). The toxicity of several oil-spill removers to some species of fish and shell-fish. Mar. Biol., 1: 322-328.
(toxicité d'agents utilisés pour le nettoyage de déversement d'hydrocarbures chez certaines espèces de poissons et coquillages.)
- Sprague, J.B. (1969). Measurement of pollutant toxicity to fish. I`Bioassay methods for acute toxicity. Water Research, 3: 793-821.
(mesures de toxicité des polluants)
- Stark, G.T.C. (1967). An automatic dosing apparatus made with standard laboratory ware. Lab. Pract., 16: 594-595.
(dispositif de dosage automatique exécuté avec un équipement courant de laboratoire.)

ANNEXE I : EXEMPLE D'UN PROCEDE D'ESSAI DE TOXICITE APPROPRIE

L'exemple suivant est le procédé d'essai actuellement utilisé par le laboratoire Fisheries Laboratory, de Burnham-on-Crouch, G.B.. La méthode d'essai implique le remplacement continu des solutions d'essai. L'appareil à écoulement continu est décrit en détail ailleurs (Connor and Wilson, 1972) et une courte description est donnée ici seulement. L'appareil a été construit pour alimenter chacun des vingt aquariums de traitement en plastique transparent (perspex), d'une contenance de 10 litres en eau de mer contenant la substance chimique à concentration constante. L'eau de mer est tirée de la mer par pompage (salinité: 29-31‰) et recueillie dans des cuves où elle se repose avant d'être envoyée au laboratoire ou elle est filtrée et recueillie dans la cuve-reservoir ou elle est chauffée (ou refroidie) à une température de 15°C (Voir figure 1). L'eau de la cuve-reservoir est pompée sans arrêt vers le bac collecteur à une vitesse qui excède les besoins des aquariums, le trop-plein retournant dans la cuve reservoir. Le bac collecteur alimente chaque aquarium de traitement séparément, chaque écoulement traversant son propre indicateur réglable et calibré pour passer dans la cuve de mélange. La substance chimique conservée dans une bouteille reservoir, est mesurée et passe dans la cuve de mélange à une vitesse constante au moyen d'une pompe péristaltique. Là, elle se mélange avec l'eau de mer courante et la solution ainsi formée quitte la cuve et passe dans l'aquarium de traitement avant d'être évacuée. Tous les écoulements sont réglables mais dans l'hypothèse de cette expérience, l'alimentation en eau de mer des aquariums se faisait au taux de 10 l/heure et le bouillon à 6,67 ml/heure; La concentration requise dans les aquariums est obtenue en préparant des solutions des substances chimiques à des concentrations 1500 fois plus élevées que la concentration requise. Des solutions fraîches sont préparées toutes les 48 heures. Quinze crevettes (Crangon crangon), longueur 50-60mm, poids mouillé 1,0-1,7 g, sont ajoutées à l'aquarium. Deux aquariums sont utilisés pour chaque concentration. Deux aquariums de contrôle reçoivent seulement de l'eau de mer. Les cuves sont fréquemment inspectées et les crevettes crevées, c.a.d. celles qui ne réagissent pas lorsqu'on les touche, sont retirées, mesurées et pesées, puis congelées pour une analyse chimique ultérieure. Les animaux ne sont pas nourris pendant l'expérience qui dure deux semaines. L'eau dans chaque cuve est analysée deux fois par jour pour la substance chimique (les détails de la méthode d'analyse devraient normalement être donnés ici). Les niveaux d'oxygène dissous sont contrôlés quotidiennement.

La distribution des temps de survie des crevettes est apparue conforme à la normale pour chaque concentration (les résultats types sont indiqués sur la figure 2) et les résultats ont été analysés graphiquement pour déterminer les temps de survie moyens (ET₅₀) et des limites de confiance de 95% (Litchfield

les temps de survie moyens (ET_{50}) et des limites de confiance de 95% (Litchfield 1949). La courbe concentration-survie résultante est indiquée sur la fig. 3.

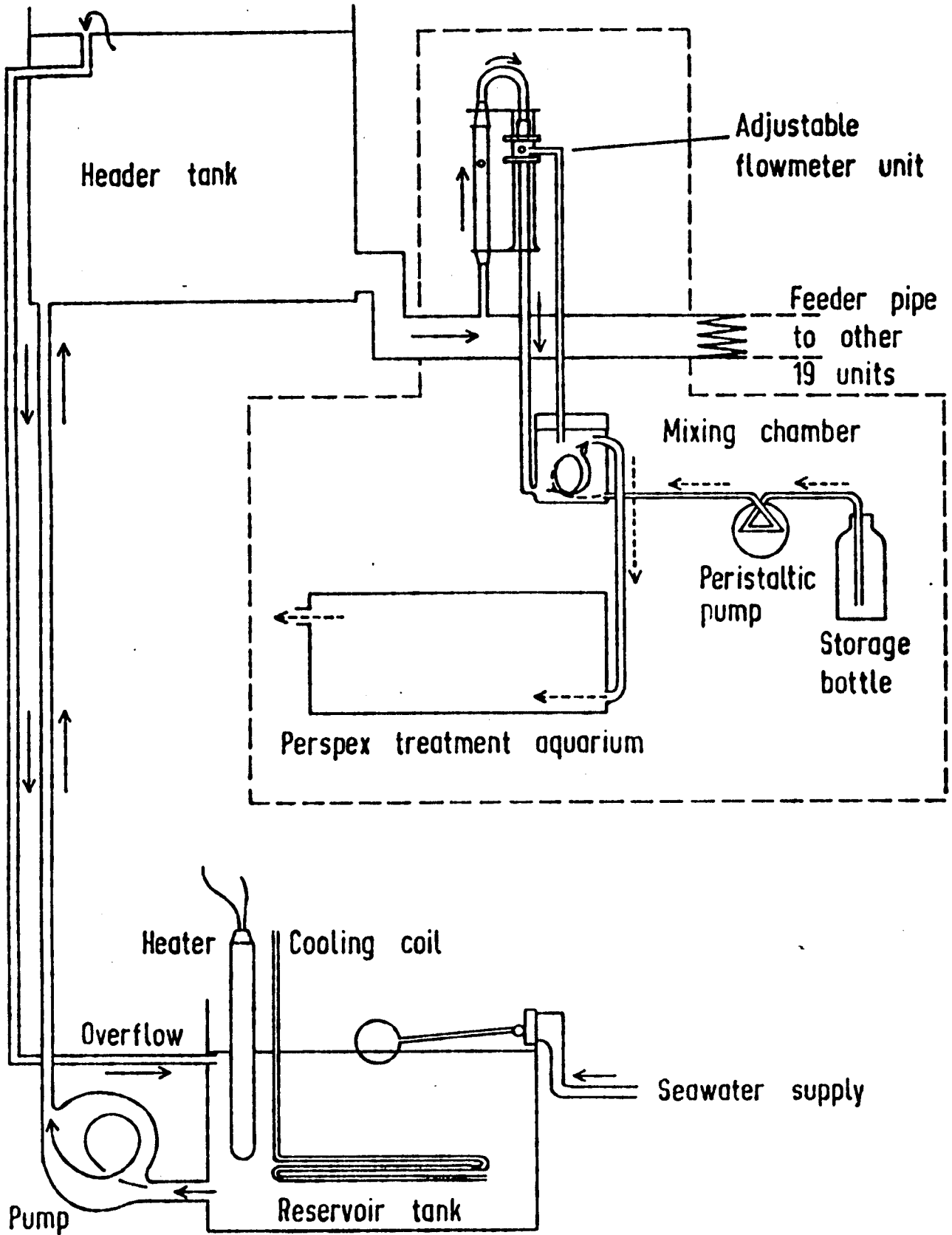

Figure 1 Diagram of the continuous flow apparatus. Only one treatment unit is shown.

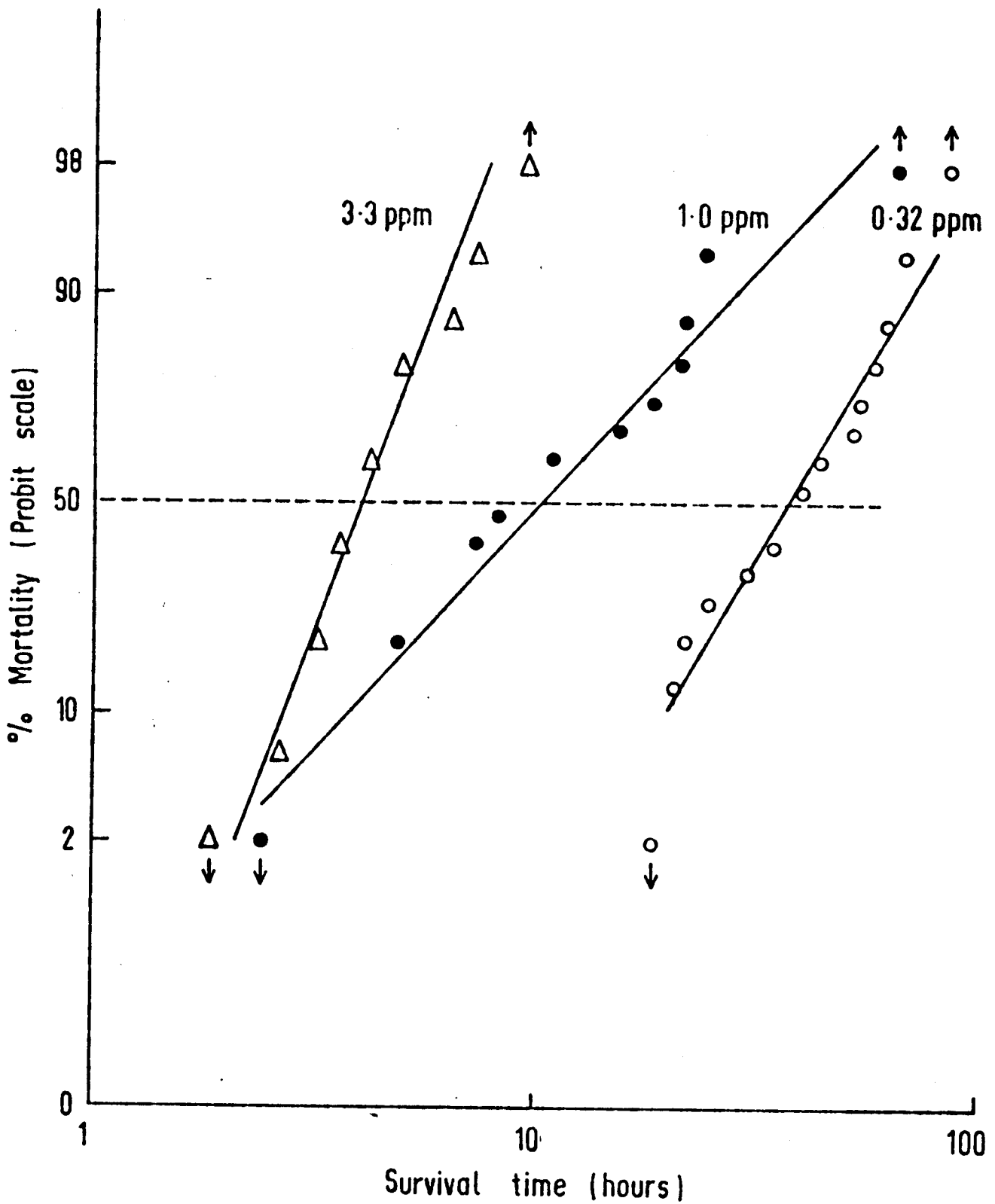

Figure 2 The accumulative percentage mortality curves for the brown shrimp. The ET_{50} is the time that each line intersects 50 per cent mortality.

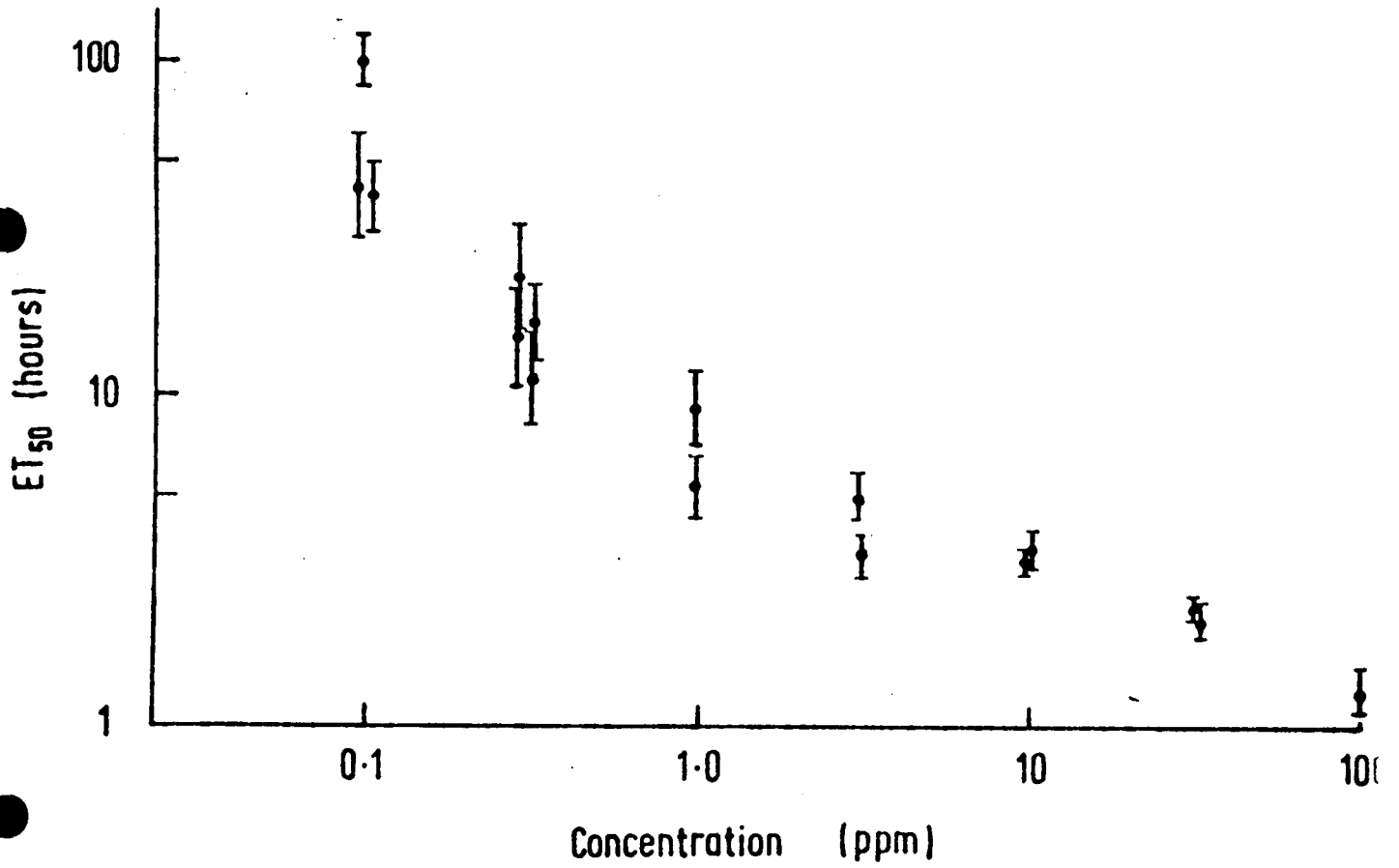

Figure 3 Survival-concentration curve for Crangon
Mean and 95 per cent confidence limits are shown for each determination.

ANNEXE II : MINIMUM DE DETAILS REQUIS POUR LA PRESENTATION DES RESULTATS
D'ESSAIS DE TOXICITE

A. PROCEDE

1. Matériel d'essai - (description physique et chimique)
2. Réaction du matériel d'essai avec l'eau de mer (solubilité, précipitation)
3. Identité et concentration du solvant utilisé - si nécessaire.
4. Eau de mer de dilution: origine (naturelle, synthétique).
salinité
température
pH
charge solide en suspension ou niveau de filtrage
5. Méthode de traitement (statique, remplacement, écoulement continu).
6. Equipement et taille des cuves.
7. Rythme de remplacement
8. Degré d'aération.
9. Nombres de traitements c.a.d. de concentrations.
10. Nombre de doubles par traitement.
11. Espèces (identité au niveau spécifique, origine etc.).
12. Longueur/poids des animaux.
13. Nombre d'animaux par cuve.
14. Débit d'alimentation.
15. Définition

B. RESULTATS

Ceux-ci peuvent être présentés sous forme de tableaux ou à l'aide de graphiques.

1. Temps effectifs moyens (ou concentration) avec variation, fonction de pente ou limites de confiance pour chaque série d'observations (temps/ concentration). L'autorité de la méthode doit être citée. Voir item 7 sur les concentrations.
2. Les rapports entre les temps et la concentration doivent être donnés, de préférence sous forme d'une courbe de toxicité.
3. durée des expériences.
4. Mortalité de contrôle.
5. Mortalité dans les concentrations où la moyenne de mortalité n'a pas été obtenue
6. Niveaux d'oxygène dissous.
7. Résultats des analyses donnant les concentrations réelles et non nominales des concentrations.
8. Résultats des analyses effectuées sur les animaux morts.

SCHÉMAS

Schéma 1 : Appareil à écoulement continu. Une seule unité est représentée.

Schéma 2 : Courbes de mortalité par pourcentage accumulé pour la crevette Crangon. ET_{50} est le point d'intersection de chacune des lignes avec la ligne indiquant 50% de mortalité.

Schéma 3 : Courbe survie/concentration pour le Crangon.

Moyenne est 954 de limites de confiance sont indiquées pour chaque détermination.

ANNEXE III

SECRETARIAT DE LA COMMISSION D'OSLO
COMITE CONSULTATIF PERMANENT
POUR LES AVIS SCIENTIFIQUES

CINQUIEME REUNION

STOCKHOLM 19-21 SEPTEMBRE 1977

TITRE : METHODOLOGIE DES TESTS

PRESENTE PAR : LA FRANCE

POINT DE L'ORDRE DU JOUR : 3

SOURCE : SACSA, Nantes(76), paragraph 15

FRANCE

CONVENTION POUR LA PREVENTION DE LA POLLUTION MARINE
PAR LES OPERATIONS D'IMMERSIONS EFFECTUEES PAR LES NAVIRES ET AERONEFS

METHODOLOGIE DES TESTS : - RECUPERATION
- INHIBITION DE CROISSANCE DU PHYTOPLACTON

TEST DE RECUPERATION

La présentation des résultats du test de récupération devrait, en plus des détails minimum nécessaires à l'interprétation de tout test de toxicité, s'accompagner des informations suivantes :

- Durées des périodes d'immersion :

1 h, 2 h et 4 h paraissent convenir le mieux pour des animaux n'ayant pas la faculté de s'isoler du milieu (poissons, crustacés). Par contre pour les bivalves filtreurs la durée de cette période peut être notablement augmentée.

- Durée de la période d'observation :

96 h sont au minimum nécessaires pour observer les effets létaux imputables aux périodes d'immersion.

- Courbes d'évolution de la concentration du ou des polluants majeurs du déchet pendant la période d'immersion la plus longue : on se basera sur des résultats d'analyses pratiquées sur des prélèvements effectués au cours du test biologique.

- Débit de renouvellement de l'eau de mer propre pendant la période d'observation.

- Définition du critère de létalité :

L'absence de réaction au toucher peut être considérée comme un critère de létalité applicable à une majorité d'espèces. Cependant, en ce qui concerne plus particulièrement les moules, l'absence de fixation du byssus à l'issue de l'expérimentation peut constituer un élément d'information important.

- Expression des résultats :

Un tableau rassemblant les taux de mortalité enregistrés permet d'estimer les concentrations limites qui n'entraînent pas d'effet après respectivement 1 h, 2 h et 4 heures de contact avec le déchet.

Exemple d'un mode opératoire du test de récupération tel que pratiqué au laboratoire de l'I.S.T.P.M. à NANTES (F)

Une série de bains expérimentaux aux concentrations désirées est préparée à partir d'eau de mer naturelle décanté (salinité 21-30‰, température 18° C). Le mélange d'effectue par agitation mécanique dans une fiole jaugée de deux litres, bouchée émeri. Après dissolution complète le contenu est transvasé dans un aquarium en verre de 4 litres dépourvue de système d'aération.

Des lots homogènes d'animaux acclimatés, comprenant de 10 à 20 individus suivant leur taille, sont introduits et maintenus dans les aquariums pendant des périodes de 1, 2 et 4 heures suivant le schéma ci-dessous

		Concentrations	
		C_1	C_n
	0	C_1 - 1 heure	C_n - 1 heure
Par espèces		C_1 - 2 heures	C_n - 2 heures
	témoins	C_1 - 4 heures	C_n - 4 heures

Une fois le temps d'exposition écoulé, les animaux sont soigneusement recueillis sur un tamis, rincés et placés dans des aquariums contenant de l'eau de mer propre renouvelée au moins deux fois par jour. Le comportement des individus est observé et les mortalités comptabilisées au bout de 48 et 96 heures.

Pendant cette période, les organismes peuvent être alimentés suivant le cas, soit avec des adultes ou des nauplii d'Artemia salina, soit avec des cultures de phytoplacton.

Le tableau ci-après donne les résultats obtenus avec différentes concentrations de DICHLORETHYLENE.

L'évolution des concentrations en fonction du temps d'immersion mesurée dans les conditions du test est représentée sur la figure jointe.

D I C H L O R E T H Y L E N E :

Civelles d'Anguilla anguilla (anguille)

		POURCENTAGES DE MORTALITE	
		48 H	96 H
78,65 mg/l	$\frac{1}{2}$ H	0	0
	1 H	0	0
	2 H	0	0
	4 H	0	0
90,75 mg/l	$\frac{1}{2}$ H	0	0
	1 H	6,4	6,4
	2 H	6,8	6,8
	4 H	28,5	28,5
102,85 mg/l	$\frac{1}{2}$ H	0	0
	1 H	33,3	33,3
	2 H	12,9	12,9
	4 H	31,0	31,0
108,9 mg/l	$\frac{1}{2}$ H	12,9	12,9
	1 H	13,7	13,7
	2 H	41,9	41,9
	4 H	90,0	90,0
121,0 mg/l	$\frac{1}{2}$ H	18,5	18,5
	1 H	25,8	25,8
	2 H	90,3	90,3
	4 H	100,0	100,0
127,05 mg/l	$\frac{1}{2}$ H	10,0	10,0
	1 H	64,5	64,5
	2 H	96,6	96,6
139,15 mg/l	$\frac{1}{2}$ H	23,3	23,3
	1 H	65,6	65,6
	2 H	100,0	100,0
151,25 mg/l	$\frac{1}{2}$ H	63,3	63,3
	1 H	79,3	79,3
	2 H	100,0	100,0

Pourcentages de mortalité, à 48 et 96 heures, pour des civelles exposées 30 mn, 1, 2 ou 4 heures à différentes concentrations de dichloréthylène.

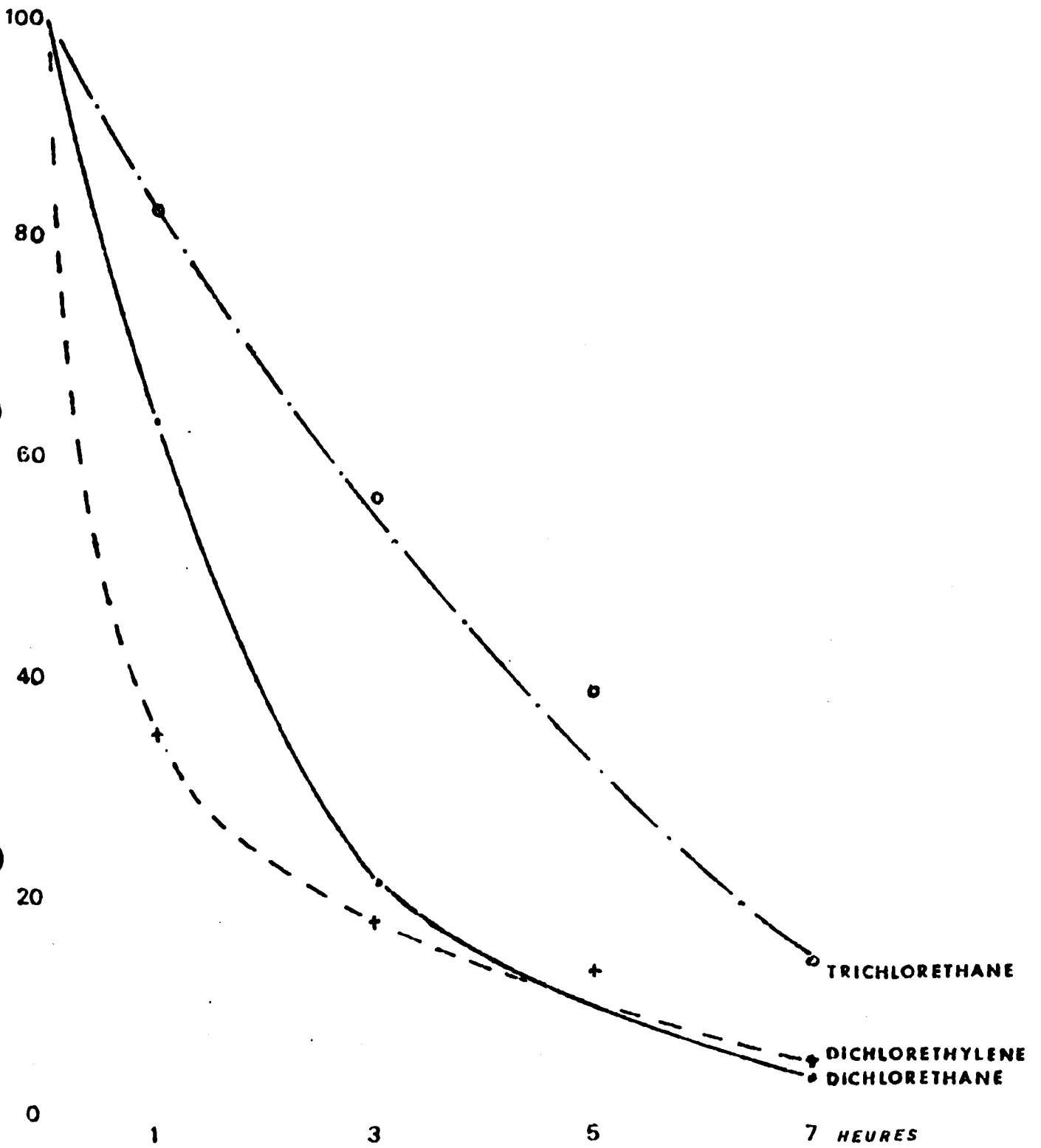

Persistence des organochlorés en eau de mer

INHIBITION DE CROISSANCE DU PHYTOPLANCTON

Le minimum d'informations spécifiques aux tests d'inhibition de croissance du phytoplancton et nécessaires à leur interprétation, doit comprendre :

- la composition chimique du milieu de culture,
- la température d'incubation,
- la durée de la période d'éclairement et l'intensité lumineuse,
- le nombre de cellules par unité de volume, contenues dans la culture servant d'inoculum,
- la méthode utilisée pour le dénombrement des cellules :
 - . coulter counter,
 - . spectrophotomètre (densité optique),
 - . respirométrie,
- la technique de conservation des souches mères :
 - . identité de la souche,
 - . milieu de repiquage,
 - . fréquence des repiquages,
- méthode de calcul de l'inhibition de croissance.

./....

Exemple d'un mode opératoire du test sur l'inhibition de croissance du phytoplancton tel que pratiqué à l'I.S.T.P.M. à NANTES (F).

Les cultures sont effectuées en tubes à essais, munis d'un bouchon type Cap-0-test, sur milieu nutritif E. S. de PROVASOLI. Chaque tube reçoit successivement :

- 8,5 ml de milieu nutritif,
- 1 ml d'une dilution, à titre connu, du déchet dans de l'eau de mer,
- 0,5 ml d'un inoculum contenant environ 10^5 cellules d'une souche pure en phase de croissance exponentielle.

Les quantités de déchets introduites sont calculées de telle sorte que l'on ait une série de concentrations croissantes comprenant 4 à 5 tubes témoins et au moins 3 tubes par concentration de façon à établir une moyenne de croissance.

Les cultures sont incubées à $18 \pm 1^\circ \text{C}$ et éclairées 12 heures sur 24 sous une intensité supérieure à 2000 Lux. Afin de limiter la sédimentation naturelle des algues benthiques il est nécessaire d'agiter les tubes régulièrement.

La croissance cellulaire est suivie quotidiennement soit par dénombrement des cellules au microscope ou au "coulter counter" soit par mesure de la densité optique de la culture.

Espèces test

Les espèces phytoplanctoniques qui se prêtent le plus facilement à la culture en milieu artificiel sont généralement des diatomées ou des flagellés. A titre indicatif, les espèces suivantes peuvent être considérées comme les plus fréquemment utilisées.

Diatomées : Gyrosigma spencerii, Phaeodactylum tricornutum,
Skeletonema costatum,

Flagellés : Dunaliella tertiolecta, Isochrysis galbana, Monochrysis
lutheri, Tetraselmis suecica,

Les souches sont conservées en milieu stérile et entretenues par repiquage successifs au mois 2 fois par mois.

Le milieu E.S. de PROVASOLI est préparé à partir de 4 solutions dont la composition chimique est la suivante :

Solution I

Fe (NH ₄) ₂ (SO ₄) ₂ , 6 H ₂ O	7,020 g
Na ₂ EDTA	6,600 g
H ₂ O QSP	1 1

SOLUTION II

H ₃ BO ₃	11,400 g
Fe Cl ₃ , 6 H ₂ O	0,490 g
Mn SO ₄ H ₂ O	1,640 g
Zn SO ₄ 7 H ₂ O	0,220 g
Co SO ₄ 7 H ₂ O	0,048 g
Na ₂ EDTA	10,000 g
H ₂ O QSP	1 1

SOLUTION III

Métasilicate de sodium NaSiO ₃ , 5 H ₂ O	100 mg
Eau distillée QSP	1 1

SOLUTION IV

NaNO ₃	70,000 g
Na ₂ Glycerophosphate	10,000 g
Solution I	500 ml
Solution II	500 ml
Solution III	2 ml
Vitamine B12	0,002 g
Thiamine	0,100 g
Biotine	0,001 g
TRIS	100,000 g
H ₂ O QSP	2 l

On ajuste le pH à 7,8 avec HCl fumant

Le milieu de culture définitif est obtenu par addition de 2 ml de solution IV à un litre d'eau de mer et stérilisé par autoclavage à 120° C pendant 30 minutes.

Expression des résultats

La courbe de croissance est établie point par point jusqu'à la fin de la phase exponentielle (annexe I) et sert de base pour déterminer l'inhibition qui est exprimée en % de croissance par rapport aux témoins.

La courbe donnant le pourcentage de croissance par rapport aux témoins en fonction de la concentration en déchet permet de déterminer graphiquement la concentration entraînant une réduction de 50 % de la croissance normale.

./.....

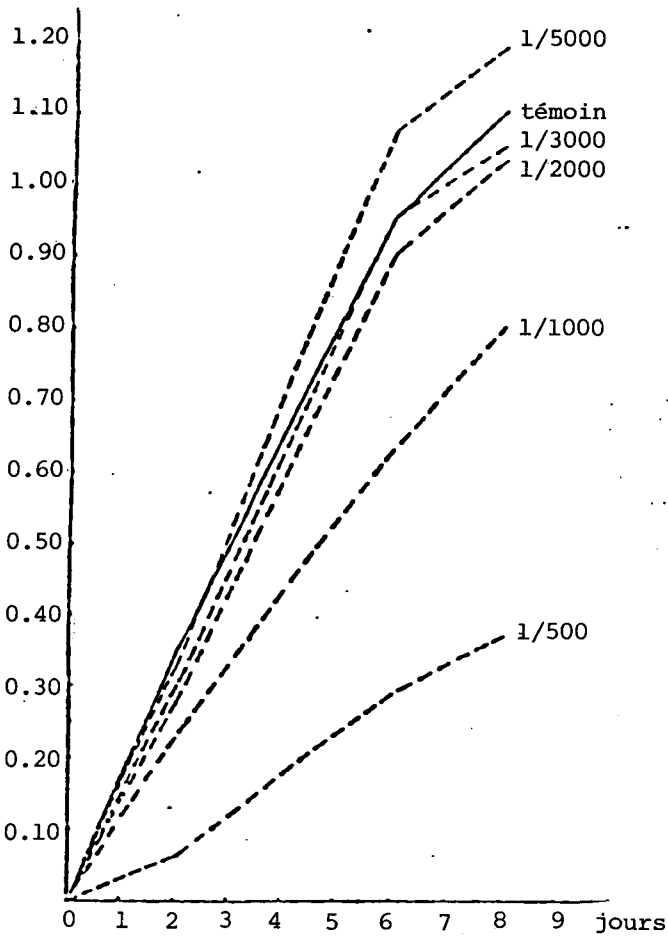

Phaeodactylum tricornutum

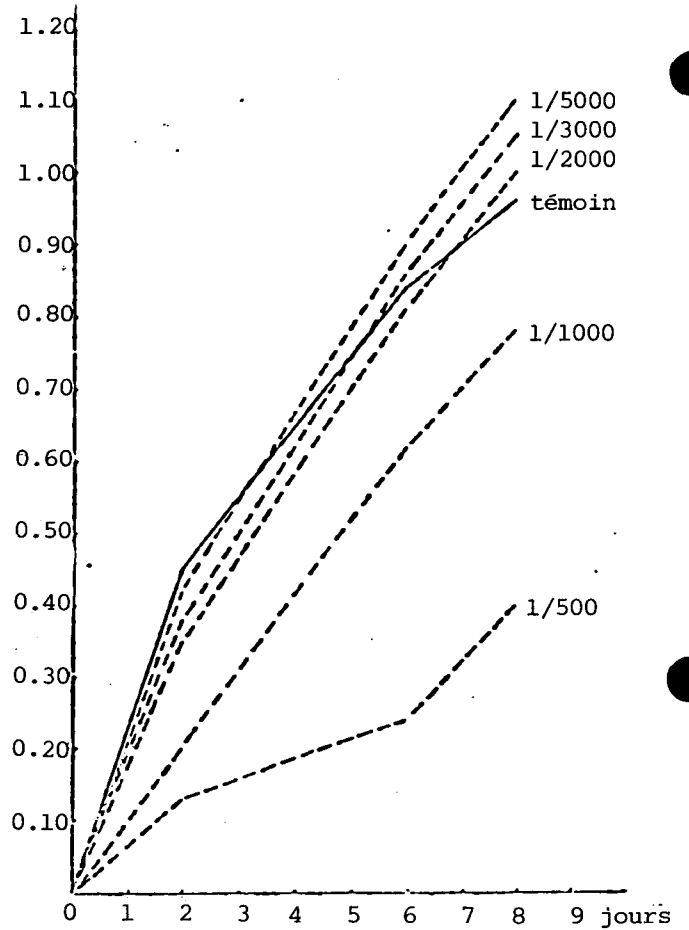

Gyrosigma sponcerii

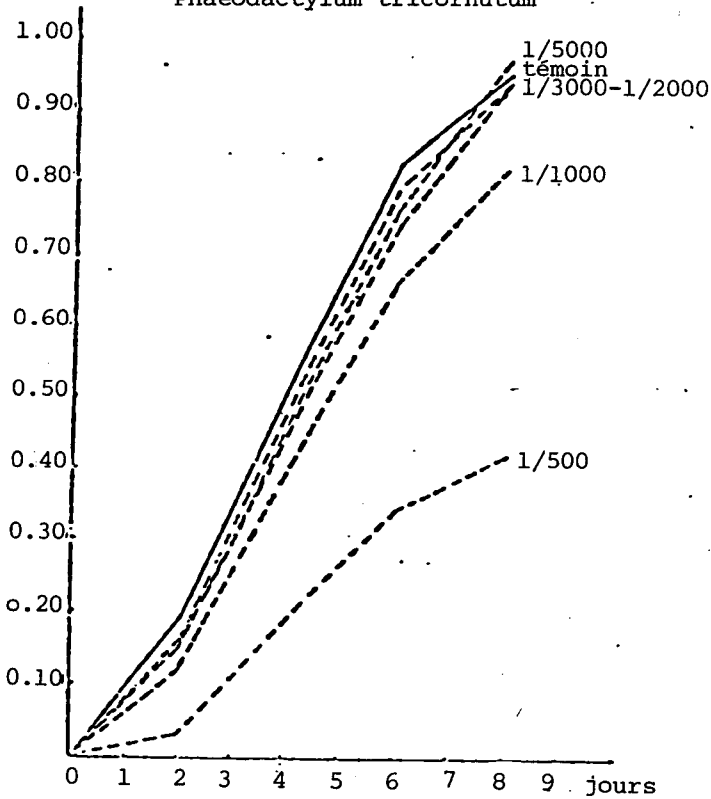

Dunaliella tertiolecta

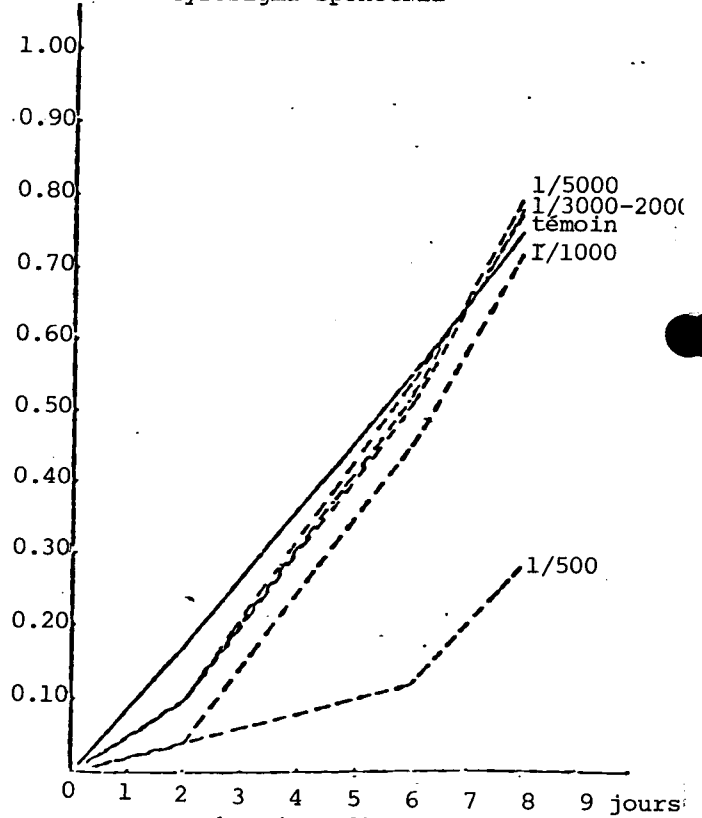

Isochrysis galbana

Courbes de croissance de 4 espèces phytoplanctoniques en présence de différentes dilutions d'un effluent industriel.(22.05.73).

ANNEXE II

Références bibliographiques

ALZIEU (Cl.), 1972. - Toxicité relative de produits antipétrole sur deux organismes marins. - Rev. Trav. Inst. Pêches Marit., 36(1), p. 103 - 109.

LACAZE (J.C.), 1969. - Effets d'une pollution du type "Torrey Canyon" sur l'algue unicellulaire marine Phaeodactylum tricornutum. - Rev. Intern. Oceanogr. med., 13-14, p. 157 - 179.

LASSUS (P.), 1974. - Etude de la toxicité de solutions acides de sels de fer sur le plancton marin. - Thèse de doctorat 3^{ème} cycle. Marseille.

PROVASOLI (L.), Mc LAUGHLIN (J.) et DROOP (M.); 1957. - The development in artificial media for marine algae. - Arch. microbiol., 12 (3), p. 392 - 428.

MINISTÈRE DE L'AGRICULTURE, DES PÊCHERIES ET DE L'ALIMENTATION
(Ministry of Agriculture, Fisheries and Food)

Fisheries Laboratory
Remembrance Avenue
Burnham-on-Crouch
Essex
ANGLETERRE
CMO 8HA

Notre réf : BLR 1040

Le 4 Septembre

Monsieur N.J. SPIJKER
Rijkswaterstaat
Directie Noordzee
Nijverheidsstraat 1
Rijswijk (z.h.)
PAYS-BAS

Cher Monsieur,

Nous vous remercions de votre lettre du 18 Août 1978 contenant des remarques sur le document SACSA 76 (10) soumis par le Royaume-Uni et devant être utilisé dans le cadre des " Procédures de Consultation Préalable " de la Commission d'Oslo.

Sur la question de savoir si le document doit spécifier une durée de test, et si oui, quelle durée doit être employée, nous continuons de penser (comme dans le document SACSA 76 (10) que le critère dominant est de définir la situation de la concentration létale asymptotique médiane. Suivant notre expérience, un seuil réaliste peut dans la plupart des cas être déterminé par une expérience se déroulant sur 4 à 6 jours, ceci évitant les facteurs de complication liés à la privation d'aliments ou au régime alimentaire dont vous signalez la présence dans des expériences plus longues. Toutefois, lorsque ce seuil de toxicité aiguë n'est pas atteint lors d'une telle expérience, il est nécessaire, conformément aux exigences du document SACSA 76 (10) de prolonger la durée du test jusqu'à ce qu'un seuil réaliste soit atteint, ce qui pourrait vraisemblablement étendre l'expérience à une durée de 7 - 14 jours comme vous le proposez. Nous pensons néanmoins que le fait de spécifier une durée de 7 à 14 jours pour toutes les substances et espèces cobayes serait une erreur, et nous préfererions conserver la souplesse inhérente au document SACSA 76 (10) qui permet de décider de la durée de l'expérience à la lumière des situations particulières.

Nous envisageons donc de tester une première fois toutes les substances pendant 4 à 6 jours à l'aide d'animaux soumis à une diète totale. Si l'on ne parvenait pas à obtenir un seuil létal médian satisfaisant par cette méthode, une nouvelle

expérience, tenant compte de la conservation et de l'alimentation des organismes cobayes sur une période prolongée bien qu'indéfinie, serait effectué jusqu'à détermination de ce seuil.

J'ai fait parvenir copie de la présente à Dik TROMP.

Je vous prie d'agréer, Cher Monsieur, l'expression de ma parfaite considération.

M.G. NORTON

CENTRAAL LABORATORIUM TNO
DELFT

D 76/85
Aug 27, 1976

Chronic toxicity testing with ARTEMIA SALINA (Linnaeus, 1758)

(Crustacea, Anostraca), the brine shrimp

by D.M.M. Adema

Application : This technique can be applied to the testing of substances soluble in sea-water. In addition to mortality due to chronic toxicity, growth - and reproduction-inhibition can be measured - these can be more sensitive indicators of toxicity than mortality in acute toxicity tests.

Principle : Measurement of the mortality and reproduction of Artemia salina (Crustacea, Anostraca) is used as an indication of the toxicity of substances dissolved in water. Experimental animals are subjected to various concentrations of the test substance in sea-water for a period of several weeks. The mortality and reproduction are compared with those of un-exposed animals.

1. INTRODUCTION

Artemia salina occurs almost throughout the world in natural and artificial salt water ponds and lakes, however not in the open sea. Artemia can be easily cultured in sea-water, thus its absence from the open seas can probably be ascribed to ecological rather than physiological reasons (Grogham 1958).

Artemia produces two types of eggs - eggs which hatch in the eggsack and cysts which are surrounded by a hard shell and are able to withstand unfavourable conditions. These cysts are collected and sold commercially; by placing in salt water they can be easily hatched and cultured, without much trouble, to adult, larvae-producing animals. As a result of the availability of these cysts and because of the simple culture techniques needed the literature on Artemia is quite extensive (see appendix 1, par. 3).

The hatching of the cysts and the growth rate of the larvae depend on a number of environmental factors (Hentig 1971). In addition the growth rate is dependent on kind and amount of food (Sorgeloos and Persoone 1975, b). Grown in sea-water of 28 ‰ salinity at 24°C and with $1 \cdot 10^7$ - $5 \cdot 10^7$ cells of the phytoflagellate Dunaliella viridis per individual, the first copulation takes place after about 10 days and the first young are born about 6 days later.

Artemia can survive 14 days at a dissolved oxygen level of 2 - 40 mg/l (Fox and Taylor 1955), however at an oxygen level lower than 3.5 mg/l a detectable deterioration of condition is observed (personal observations).

Since very few of the "real" marine crustaceans can be cultured, and then only with great difficulty and because its larvae are easily obtainable, Artemia is widely used in toxicity tests applied to the marine environment, in spite of the fact that the animal does not occur there naturally.

Toxicity tests are carried out with larvae from commercially obtained cysts, with adult animals, or with larvae which develop into adults in

the course of the test. From comparative toxicity tests (Brown and Ahsanullah 1971, Wisely and Blick 1967, Corner and Sparrow 1956) it appears that Artemia is fairly resistant in comparison with other marine organisms; however, because it is really the only pelagic crustacean that can be easily obtained and is easily grown in sea-water in the laboratory, it is nevertheless chosen as a standard test organism for chronic toxicity tests in sea-water.

2. MATERIALS

- Brine shrimps, about three days old and born from adults about three weeks old (for culturing procedure, see appendix 1).
- Suspension of the unicellular alga Dunaliella viridis in sea-water, with a cell density of about $3 \cdot 10^8$ cells/ml (for culturing procedure, see appendix 2).
- Glass beakers or aquaria and glass conical flasks, 2 l.
- Temperature regulated room, temperature $24 \pm 1^\circ\text{C}$, moderately illuminated for about 8 h per day (the lighting is not critical).
- Automatic (or ordinary) pipettes, 1 ml.
- Automatic pipettes, 0.1 ml.
- Volumetric flasks, 100 ml and 1000 ml.
- Measuring pipettes, 1 ml and 10 ml.
- Measuring cylinders, 100 ml and 1000 ml.
- pH meter.
- Oxygen meter.
- Salinity meter.
- Good quality natural sea-water or an artificial sea-water, in which the brine shrimps can develop normally (see appendix 1).
- Glass tubes, 20 cm long, diameter 3 mm and 6 mm, fitted with a teat.
- Apparatus for aeration.

3. METHOD FOR CHRONIC TOXICITY TESTING

3.1 Solubility of the test compound

The solubility of the experimental compound in sea-water must be determined before the test is carried out, and this concentration must not be exceeded during the test. For liquids and waste water the miscibility with sea-water and the stability of the resultant diluted solution must be determined. If a solvent other than water is used for dosing the test compound, the final concentration of the solvent should not be toxic for the brine shrimps nor rapidly broken down and must be miscible with water; tert-Butanol, diluted 0.5:10⁴ can be used.

3.2 Choice of test vessel

Glass beakers, or other suitable glassware, of 2l, covered with a glass plate, are used. If initial investigation has shown that the test substance is volatile, codistills with water or adsorbs to glass, and in all cases where incomplete information is available, special precautions must be taken. Volatile and codistilling compounds can be tested in almost full 2l conical flasks covered with a clock glass. Substances which adsorb to glass must be tested in glassware equilibrated with the test substance by prior rinsing in the experimental solution.

3.3 Choice of concentrations

It is assumed that preceding acute toxicity testing has provided a value for the LC₅₀.48 h for the experimental compound. For chronic toxicity testing a concentration range of about 0.01 LC₅₀.48 h to 1.0 LC₅₀.48 h is used. The intermediate concentrations are chosen in a geometrical series, the ratio of which depends on the desired accuracy. Examples of suitable concentration series are given in table 1.

Table 1 Suitable concentration series for toxicity tests

concentration series (e.g. in mg/l)	ratio	purpose
1.0 3.2 10 etc	$\sqrt{10} = 3.16$	rough testing
1.0 1.8 3.2 5.6 10 etc	$\sqrt[4]{10} = 1.78$	routine testing
1.0-1.3-1.8-2.4-3.2-4.2-5.6-7.4-10 etc	$\sqrt[8]{10} = 1.33$	accurate testing

3.4 Preparation of the test solutions of desired concentrations

3.4.1 Substances easily dissolving in water or liquids easily mixing with water

Stock solutions are prepared in distilled water at a concentration of at least $2 \cdot 10^2$ but preferably $2 \cdot 10^3$ times the experimental concentration. The required concentration in the experimental vessel is obtained by diluting $0.5:10^2$ or $0.5:10^3$ with sea-water.

3.4.2 Pure substances not sufficiently soluble in water to make concentrated stock solutions

If it is possible to measure the level of the test compound in solution by analysis then the highest concentration needed can be prepared by shaking or stirring the appropriate amount of the compound with sea-water until it is dissolved. The required concentration can also be prepared by continuous percolation of sea-water over the test compound, for example on an inert carrier (Chadwick and Kùgemagi 1968, Veith and Comstock 1975). The appropriate level is obtained by analysis and the other concentration are prepared by dilution with sea-water. If it is not possible to analyse for the test substance in solution, or if it consists of a complex mixture of substances, then this technique

is not recommended. In these cases a $2 \cdot 10^4$ stock solution is prepared in tert-butanol or another suitable organic solvent (see par. 3.1). This stock solution is then diluted $0.5:10^4$ in sea-water in the experimental vessels; however the solubility of the test compound in sea-water must not be exceeded in that case.

3.5 Control solutions (blanks)

For each concentration series a blank experiment (sea-water without test substance) must be carried out. If a solvent other than distilled water is used for the test substance, an additional blank must contain this solvent in the same final concentration.

3.6 Multiplicity

The whole test must be carried out, at least, in duplicate.

3.7 Quality controls

The sea-water used must comply with the following quality requirements:

- synthetic sea-water, prepared from commercially available seasalt dissolved in good quality distilled water or in deionized water filtered through active charcoal can be used.
- uncontaminated filtered natural sea-water can also be used, provided the growth results obtained in this water comply with those described in appendix 1, par. 2.
- the salinity of natural sea-water varies from location to location, but can, if necessary, be adjusted to the required value by dilution or addition of seasalt.
- the pH and oxygen level can be brought, by aeration, to values of 8.0 ± 0.1 and 6.7 mg/l respectively.

3.8 The test itself

A sufficient number of 2 l aquaria or beakers (for polar substances) or 2 l conical flasks (for nonpolar substances) are set out in the temperature regulated room, and are coded for test substance and concentration and with "a" or "b" for the duplicates. If a concentrated stock solution of the test compound is to be used, the vessels are approximately half filled with sea-water at about 24°C and the test compound is then added. If the test compound is in aqueous solution then 1 ml (or 10 ml, depending on the concentration of the stock solution) is added; if it is in an organic solvent then 0.1 ml (an automatic pipette is necessary for the addition of 0.1 ml, it is also advisable for 1.0 ml). The volume is then adjusted to 2 l with sea-water. If it has not be possible to prepare a stock solution the experimental vessels are filled with 2 l of a solution of the test compound in sea-water. If waste water is to be tested, it is first thoroughly mixed and, after checking the dissolved oxygen level, diluted with sea-water. If the oxygen level is too low it can be elevated before the test by aeration.

The pH and the oxygen level of the blank and of the most concentrated solution are then compared. If these are not the same, measurements of the other samples must also be made.

If oxygen saturated sea-water has been used for dilution, a final low oxygen level can indicate chemical utilization of the oxygen by the test compound or waste water. This can be corrected by further aeration, however excessive aeration leads to oxidation of the test compound or evaporation of volatile test substances.

If desired the pH is adjusted to 8.0 ± 0.1 . It must be remembered that both the condition of the brine shrimps and the toxicity of the test compound can be affected by the pH. The pH and oxygen levels (and any necessary adjustments of these) are noted.

Samples to determine the test compound level are taken if this is possible and necessary. These samplings must not significantly effect

the final volume. If more than 10 % of the volume is necessary for analysis a greater initial volume of test solution must be prepared. A sufficient volume of algal suspension (prepared as in appendix 2) is added to yield a final concentration of $2 \cdot 10^8$ cells/litre and homogeneously mixed into the solution. 20 Brine shrimps are added to each test vessel, these are sucked up using a glass tube (diameter about 3 mm) fitted with a teat and released under the water surface in the test vessel. Crosscontamination is avoided by working from lowest to highest concentrations of the test substance (the blanks are handles first) and by starting with a new supply of test animals for each test compound. The ordinary lighting of the temperature regulated room is used. If it is known that the test compound is not volatile and does not codistil with water, the vessels can be gently aerated when the brine shrimps are at least one week old (thus beginning on day 4 of the test). This maintains a satisfactory oxygen level and homogeneity during the experiment - young brine shrimps are damaged by aeration, but they consume so little oxygen that this is generally not necessary.

Algae are added daily to the test vessels, independent of whether the test solution is replaced (see below) or not. The algal concentration is gradually increased from $1 \cdot 10^7$ cells/brine shrimps on the first day of the test to $5 \cdot 10^7$ cells for adults at least 14 days old. The sea-water and test compound must both be changed daily when, as will generally be the case with nonpolar compounds, the test is carried out in unaerated conical flasks. With polar substances the solutions are changed on Monday, Wednesday and Friday - in this case aeration can be carried out if necessary and as long as this does not result in reduction of the concentration of the test substance. The replacement of the test solution is carried out as follows: a second series of test vessels is prepared and checked in exactly the same way as the first. The surviving brine shrimps (the initial generation is termed the P generation) are counted and transferred to the new vessels as previously described; wider tubes are used as soon as the growth of the brine shrimps makes this necessary. The dead animals

of the P generation are counted and removed, the sum of the living and dead individuals should tally with the initial number of brine shrimps. Newborn animals (the F_1 generation) can be expected from about day 12 of the test - these are also counted and removed. Then the pH and dissolved oxygen level of the blank and of the most concentrated solution are checked.

All observations are noted; also recorded, where relevant, are the number of male and female animals and the number of pairs, whether the female animals are carrying eggs and/or whether cysts have been deposited, as well as the (visual) condition of the F_1 generation. The old solution can be used for chemical analysis, if such analysis had also been carried out at zero time. The glassware is emptied, food remains etc. are removed, and the vessels rinsed with distilled water and kept for the following solution change, so that the same two vessels are repeatedly used for the same concentration. The test lasts at least three weeks. If necessary the whole experiment can be repeated to check the reproducibility.

4. HANDLING OF THE RESULTS

Tabulate (see appendix 3), for each test solution (the duplicates are handled separately) and each observation time, the number of survivors, larvae born per female and all other observations and measurements.

At least the $LC_{50}.48$ h, $LC_{50}.96$ h, $LC_{50}.7$ d, $LC_{50}.14$ d and $LC_{50}.21$ d, together with their 95 % confidence error, are recorded, preferably for each series separately.

The total number of larvae per female born during the test in each solution (x) is calculated, also the mean (\bar{x}). For each test solution the mean percentage reproduction inhibition is calculated by comparison with the mean of the blanks (see example given in appendix 3b).

5. CONDITIONS FOR VALIDITY OF THE TEST

The mortality of the blanks after 3 weeks should not be more than 20 %. The LC_{50} values of the one test series must lie within the 95 % confidence range of the other series, and vice versa, if it has been possible to calculate these separately.

The dissolved oxygen level in all the experimental vessels must have remained at least 70 % of the saturated value.

The pH of at least the blank and the most concentrated solution must have been known throughout the whole experiment, and if initially adjusted to pH 8.0, never have traveled outside the range 8.0 ± 0.1 .

The first young in the blanks must have been born after 13 days.

The number of live larvae born per female must not vary by more than a factor of two for any pair of duplicates and in the third week must be at least 100 for the blanks.

The daily added food must have been totally consumed by the blank cultures.

6. RECOMMENDATIONS

It is to be recommended that in addition to the series with the substance under test, a series with a so-called standard substance is carried out; the results obtained with this standard test substance should be as expected. A stable, soluble, polar substance which is not chemically or biologically broken down in the course of the experiment should be used as standard substance. It must not be a major component of sea-water and must be reasonably toxic for Artemia salina but not too toxic for laboratory handling.

Pentachlorophenol is recommended (Adelman and Smith 1976), although the purity and the human toxicity of this substance must be considered.

APPENDIX 1

CULTURING OF ARTEMIA SALINA

1. Materials

- Culture of Artemia salina or commercially available Artemia cysts
- temperature regulated room, temperature $24 \pm 1^{\circ}\text{C}$, moderately illuminated for about 8 h per day
- all-glass aquaria of about 10 l and/or all-glass separating funnels fitted with a nylon mesh (about 1 mm x 1 mm) just above the outlet tap (see fig. 1)

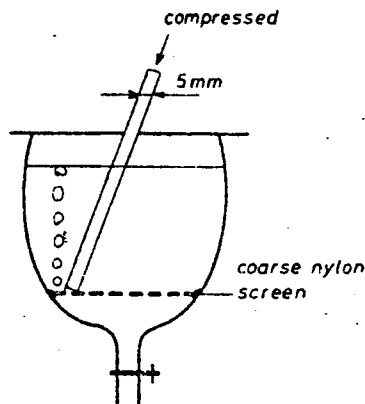

Fig. 1 Culture vessel for Artemia salina (not to scale)

- all-glass aquaria of about 2 l or disposable plastic containers of about 2 l
- funnel-shaped sieves with nylon-gauze sieveplates with a mesh of about 0.1 mm x 0.1 mm and about 1 mm x 1 mm (see fig. 2)

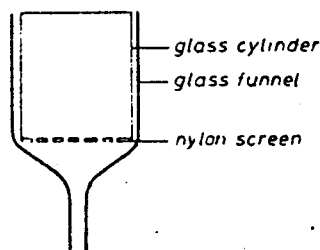

Fig. 2 Sieve, for separation of large and/or small animals and sea-water (not to scale)

- aeration tubes, diameter about 5 mm, and of a length suitable for use with the culture vessels
- apparatus for aeration
- pH meter
- suspension of Dunaliella viridis in sea-water (see appendix 2, par. 4)
- uncontaminated filtered sea-water or synthetic sea-water, salinity 28 to 30 ‰.

2. Culturing of Artemia salina

Batches of brine shrimps are cultured synchronously in sea-water. Each batch is started from newly hatched larvae, about 24 h old and preferably derived from a laboratory culture. Alternatively larvae from commercially available cysts may be used (see also par. 3).

Approximately 350 larvae are placed in 2 l sea-water in, for example, a small aquarium, in the temperature regulated room. These are fed twice daily with 5 ml Dunaliella viridis for about a week, after which time they are about 4 mm long. 300 Larvae are transferred into 10 l sea-water and the culture slowly aerated with large air bubbles fed through glass tubes of about 5 mm diameter. The brine shrimps are now fed twice daily with 25 ml algal suspension; this should be totally consumed. Twice a week half of the sea-water is replaced. If necessary the walls and the bottom of the culture vessel are cleaned. Newly born larvae are removed daily, or if they are not needed, twice a week - simultaneously with the renewing of the sea-water.

Copulation takes place from about the 10th day and the first larvae are born about 6 days later.

Either aquaria or separating funnels of 10 l can be used as culture vessels. The latter are fitted with a sieveplate of mesh 1 mm x 1 mm through which the sea-water, with or without newborn larvae, can be removed in such a way that the original animals remain behind. In this way the water

can easily be changed and larvae and adults are easily separated. In the second case the funnel is totally emptied and the adults trapped on the sieve in the neck. The larvae are then caught on a fine mesh nylon filter fitted in the funnel (see fig. 3)..

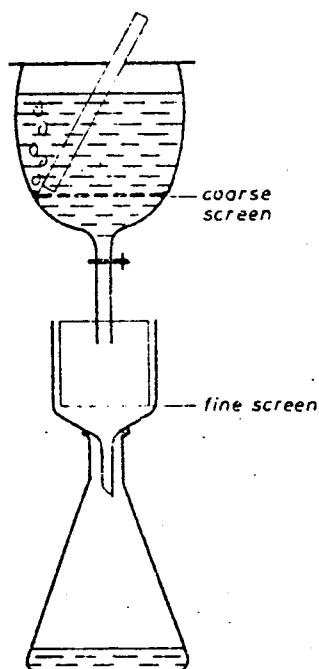

Fig. 3 Filtration unit used with funnels, for separation of adults, larvae and sea-water (not to scale)

The animal-free water is then as quickly as possible wholly or partially (if part is to be replaced) returned to the separating funnel. The larvae are returned as quickly as possible to sea-water - they can then be used for starting a new culture or for toxicity tests. In these cases it is necessary that the larvae are less than 24 h old, so daily removal of all newborn larvae is necessary.

If it is only possible to use aquaria or other simple containers for culturing, a system for the separation of adults and larvae must be improvised - for example as in fig. 4.

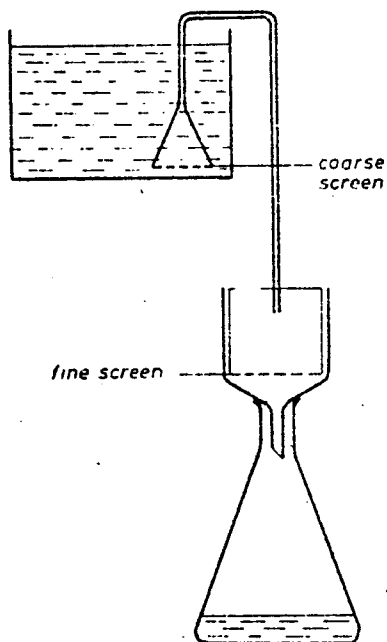

Fig. 4 Filtration unit used with aquaria, for separation of adults, larvae and sea-water (not to scale)

The last remaining quantity of water containing the adults must be filtered over a separate coarse sieve after which they are returned to the aquarium.

Each week at least one new culture is started. 6 Weeks old culture are discarded.

3. Additional comments on the culturing of Artemia salina

The system described in section 2 is only one of many possible systems for successful culturing of brine shrimps. Good results can be obtained with totally different conditions; for example - different medium or salinity, different temperature, total darkness, different food, different culture vessels etc.

We have chosen the following:

- sea-water for the brine shrimps and enriched sea-water (Erdschreiber medium) for Dunaliella viridis, since work with brine shrimps will generally be carried out by marine laboratories and these will, in general, have a source of sea-water.
- an optimum temperature for growth at the chosen salinity.
- moderate lighting during the working day. Although brine shrimps grow faster in the dark, in most laboratories the temperature regulated room is also used during the day for other purposes. Too short cycles of light and dark are unfavourable for the animals and shrouding the culture vessels can interfere with temperature regulation.
- live cells of Dunaliella viridis as food. This phytoflagellate is an excellent foodsource for brine shrimps and one of the easiest marine unicellular algae to culture in bulk. Use of living cells, in contrast to dried or freeze-dried material, simplifies the transition to and the comparison with toxicity and accumulation work with algae, and also food chain research.
- culture vessels, and other apparatus that is generally available in most biological laboratories.
- the size of the culture vessel is such that sufficient larvae are produced per 10 l per week for use in toxicity testing by one person.

The preparation of large quantities of larvae from cysts or the culturing of large quantities of brine shrimps is not described here, as these are not relevant to toxicity testing.

Further information about methods for hatching cysts and the preparation of large quantities of brine shrimps and the effect of factors such as temperature and salinity on the hatching of the cysts and the growth of the larvae are given by Hentig (1971) and Sorgeloos and Persoone (1975 a, b). In addition these authors give an extensive bibliography of work with Artemia salina.

APPENDIX 2

THE CULTURE OF DUNALIELLA VIRIDIS AS FOOD SUPPLY FOR ARTEMIA SALINA

1. Materials

- Pure or uni-algal culture of Dunaliella viridis
- temperature regulated room, temperature $15 \pm 2^{\circ}\text{C}$, with continuous lighting of about 4000 lux.
- conical flasks, 300 ml, for the pre-cultures
- pre-culture, prepared as in par. 2
- conical flasks or other heat-resistant all-glass vessels 3 to 20 l
- apparatus for aeration with water-saturated air through an air bubble
- sea-water
- sterile pipettes, 1 ml
- sterile solution of NaNO_3 in distilled water, 0.1 g/ml
- sterile solution of $\text{Na}_2\text{HPO}_4 \cdot 12\text{H}_2\text{O}$, in distilled water 0.02 g/ml
- sterile soil extract
- autoclave
- centrifuge.

2. Preparation of the pre-culture

100 ml sea-water is sterilised by autoclaving for 20 min. at 120°C in a 300 ml conical flask with cotton-wool plug. "Erdschreiber medium" is prepared by adding 0.1 ml sterile NaNO_3 solution, 0.1 ml sterile Na_2HPO_4 solution and 5 ml soil extract aseptically. This solution is then aseptically inoculated with 1 ml of the previous pre-culture (about 12 days old) and incubated for 12 days at 15°C and 4000 lux illumination; the

flasks are shaken by hand daily. After about 12 days the culture contains about $4 \cdot 10^6$ cells/ml and can be used to inoculate the food supply culture and a new pre-culture.

3. Preparation of the food-supply cultures for brine shrimps

Conical flasks, or other heat resistant glass vessels about $\frac{2}{3}$ full of sea-water and containing a bubbler on the bottom of the flask are stoppered with cotton-wool plugs and autoclaved for 2 h at 100°C . The flasks are allowed to cool and 1 ml NaNO_3 solution, 1 ml Na_2HPO_4 solution and 50 ml soil extract per litre sea-water are aseptically added. This solution is then inoculated with 100 ml of the pre-culture (see par. 2) and the flasks incubated for about 12 days at about 15°C and 4000 lux illumination. During the incubation the flasks are continuously aerated so that the algae stay in suspension, they are also shaken daily by hand. After about 12 days the cell density is about $4.5 \cdot 10^6$ cells/ml.

4. Preparation of the food suspension

The contents of the flasks are centrifuged at 2500 rpm (1500 g) for about 10 min. The supernatant is removed and the cells resuspended in sea-water at a density of about $3 \cdot 10^8$ cells/ml. This suspension can be stored about 2 weeks at 4°C without loss of food value for the brine shrimps.

5. Comment

The culture of Dunaliella viridis will generally not be bacteria-free, however this is of no importance, the Artemia salina also being non-sterile. This notwithstanding, it is still to be recommended that a sterile technique is used for the manipulation of the algal culture - excessive bacterial contamination can inhibit the growth of the algae. It is particularly recommended that a sterile pre-culture be obtained and maintained.

APPENDIX 3b

EXPERIMENT NO.:

EXAMPLE OF TABLE, USED AS SUPPLEMENT TO 3a, FOR REPRODUCTION TESTS

SHEET NO:

date	day of experiment	theoretical concentration (ppm)	number of survivors	number of σ/σ	total number of young	number of young / σ	reproduction results			
							concen.	number of young, summed over the experimental time		
								per σ (x)	mean of dupli- cates (\bar{x})	as % of blank
9-4	14	0 a	16	10/6	336	34	0 a	126	150	100 (p.d.)
		0 b	18	9/9	475	54	0 b	175		
		0,32 a	19	7/12	137	20	0,32 a	59	55	37
		0,32 b	17	9/8	267	30	0,32 b	50		
		0,56 a	19	13/6	47	4	0,56 a	39	29	19
		0,56 b	19	11/8	0	0	0,56 b	19		
21-4	16	0 a	16	10/6	374	37				
		0 b	18	9/9	357	40				
		0,32 a	19	7/12	259	37				
		0,32 b	17	9/8	164	18				
		0,56 a	18	12/6	47	4				
		0,56 b	19	11/8	28	2				
23-4	18	0 a	16	10/6	106	11				
		0 b	18	9/9	309	34				
		0,32 a	19	7/12	8	1				
		0,32 b	17	9/8	21	2				
		0,56 a	18	12/6	52	4				
		0,56 b	18	11/7	141	13				
26-4	21	0 a	16	10/6	439	44				
		0 b	18	9/9	427	47				
		0,32 a	19	7/12	4	1				
		0,32 b	17	9/8	19	2				
		0,56 a	18	12/6	319	27				
		0,56 b	18	11/7	46	4				

Reproduction inhibition

0,32 ppm : 63 % (roughly 60 %)

0,56 ppm : 81 % (roughly 80 %)

LITERATURE

- Adelman, I.R. and L.L. Smith (1976): Fathead minnows (*Pimphales promelas*) and Goldfish (*Carassius auratus*) as Standard Fish in Bioassays and their Reaction to Potential Reference toxicants.
J. Fish Res. Board, Canada 33, 209-214.
- Brown, B. and M. Ahsanullah (1971): Effects of heavy metals on mortality and growth.
Mar. Poll. Bull 2(12), 182-187.
- Chadwich, G.C. and V. Kügemagi (1968): Toxicity evaluation of a technique for introducing dieldrin into water.
Water Pollut. Control Fed. 40, 76-82.
- Corner, E.D.S. and B.W. Sparrow (1956): The modes of actions of toxic agents.
I. Observations on the poisoning of certain crustaceans by copper and mercury.
J. Mar. Biol. Ass. U.K. 35, 531-548.
- Crogham, P.C. (1958): The survival *Artemia salina* (L) in various media.
J. Exp. Biol. 35, 213-218.
- Fox, H.M. and A.E.R. Taylor (1955): The tolerance of oxygen by aquatic invertebrates.
J. Exp. Biol. 32, 214-225.
- Hentig, R. von (1971): Einfluss von Salzgehalt und Temperatur auf Entwicklung, Wachstum, Fortpflanzung und Energiebilanz von *Artemia Salina*.
Marine Biology 9, 145-182.

Sorgeloos, P. and G. Persoone (1975 a): Technological improvements for the cultivation of invertebrates as food for fishes and crustaceans.

I. Devices and methods.

Aquaculture 6, 275-289.

Sorgeloos, P. and G. Persoone (1975 b): Technological improvements for the cultivation of invertebrates as food for fishes and crustaceans.

II. Hatching and culturing of the brine shrimp, *Artemia salina* (L).

Aquaculture 6, 303-317.

Veith, G.D. and V.M. Comstock (1975): Apparatus for continuously saturating water with hydrophobic organic chemicals.

J. Fish Res. Board, Canada 32 (10), 1849-1851.

Wisely, B. and R.A.P. Blick (1967): Mortality of marine invertebrate larvae in mercury, copper and zinc solutions.

Aust. J. Mar. Fresh Wat. Res. 18, 63-72.

Young Artemia salina larvae seen by scanning electron microscopy (photo CL-TNO)



Newly born larva; 0.40 mm

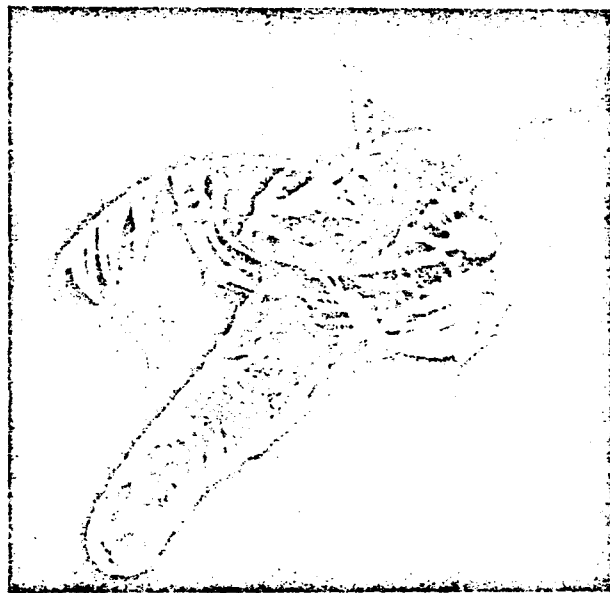

Young larva < 24 h; 0.52 mm

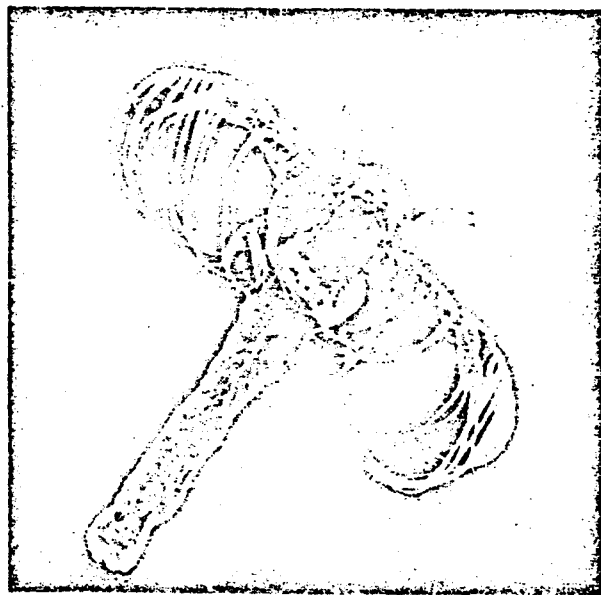

Larva < 24 h; 0.64 mm

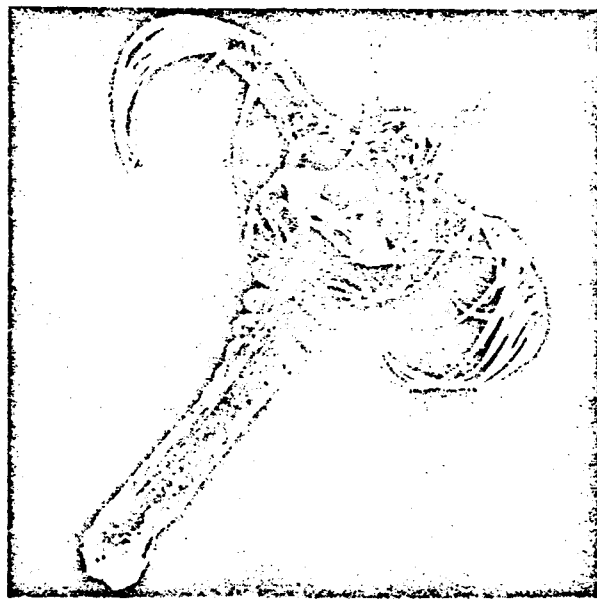

Larva, about 24 h; 0.82 mm

Artemia salina, juveniles, seen by scanning electron microscopy (photo CL-TNO)



male, about 9 days old; 5.2 mm

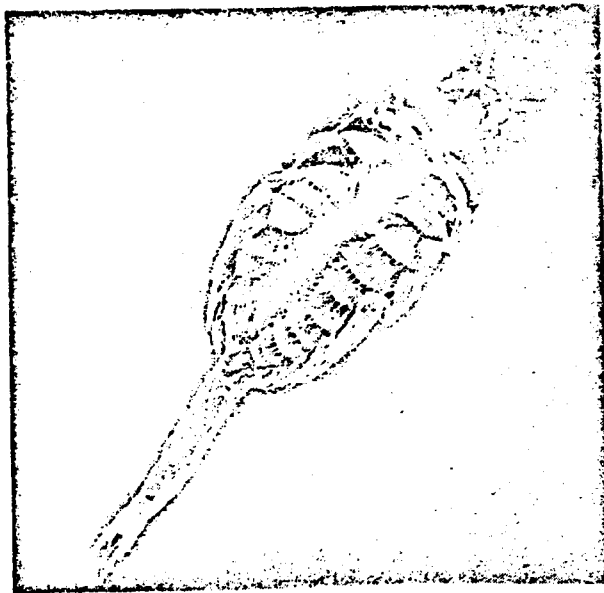

female, about 9 days old; 5.4 mm

CENTRAAL LABORATORIUM TNO
DELFT

D 76/88
Aug 30, 1976

Method for the measurement of accumulation and elimination of
xenobiotic substances by small marine organisms 1)

by D.M.M. Adema

Application: This technique can be used for substances which are soluble at the required concentration in sea-water and for which a chemical analysis, both in sea-water and in biological tissue, can be carried out.

Principle: Experimental animals are exposed to sea-water containing a known, and - during the accumulation period - constant, concentration of the test compound. This concentration, which must be well below the lethal concentration, is regularly measured by chemical analysis. At intervals the tissue concentration of the compound in a representative sample of the experimental animals is measured. The test continues, if this is possible, until the tissue concentration no longer increases, or at least 14 days. After the accumulation period the animals are placed in sea-water without the test compound; during this elimination period the level of the compound in sea-water is measured until it is no longer detectable, and at intervals the tissue level in a representative sample of the test animals is measured. The test is continued, if this is possible, until the test compound is no longer demonstrable in the tissue, or until 90 % elimination has been achieved, the minimum elimination period being one week.

1) Weight 0.5-5 g.

1. INTRODUCTION

The working group on degradation of substances in paragraphs 1 and 2 of Annex I of the "Convention for the prevention of marine pollution by dumping from ships and aircraft" met in Stockholm (9-11 April 1973), Lowestoft (11-12 March 1974), Funchal (13-16 May 1975) and again in Funchal (9-12 March 1976).

At the first meeting it was decided to study bioaccumulation and elimination of several compounds using commercial molluscs, shrimps and fishes. At the second meeting, the results of the tests carried out in several countries were discussed and compared (for these results, see the report of the Lowestoft meeting). At this meeting it was agreed to carry out more accumulation and elimination tests with certain "black list" compounds (e.g. dieldrin, DDT). The results of these tests were compared at the third meeting (Funchal, 1975; for the results, see the report of this meeting). From all the results obtained it was apparent that, using approximately the same test animals, methods and analytical procedures, the results on accumulation and elimination of a test compound obtained by different laboratories will be of the same order of magnitude.

At the same meeting (Funchal, 1975) the working group composed a list of terms and symbols to define the different parameters in use in the field of bioaccumulation and elimination. At the last meeting of the working group (Funchal, 1976) it was agreed that, in addition to toxicity and degradation, "Accumulation/elimination was a most significant factor to be considered".

It was further agreed that "The minimum requirement for this test is that one sub-lethal low concentration test should be performed on at least one species of fish and one species of mollusc".

"Accumulation should continue for 14 days and elimination at least 7 days". A test method with these minimum requirements is given in this report; the principle of the technique can easily be adapted for other animals, periods of accumulation and elimination, concentration of the test compounds etc. Some general considerations on accumulation and elimination tests, and on suitable test animals, are discussed, before a description of the test method for the minimum requirements is given.

2. GENERAL COMMENTS ON TEST METHODS

The method described here is intended for the measurement of the uptake from, and the elimination to, the surrounding sea-water of xenobiotic substances by small (several cm) marine organisms.

For the measurement of the uptake, experimental animals are exposed during an accumulation period to (at least) one constant concentration of the test compound in sea-water (C_w). This concentration must be well below the lethal concentration. At intervals the concentration (C) of the test compound in the tissue of a representative sample of the animals is measured. After a sufficient period this concentration, C , will stabilise as a result of equilibration between the concentration of the compound in the animal and in the sea-water. During the experiment the weight and composition (fat and protein levels) of the animal must not change significantly.

For the determination of elimination, use is made of animals with an artificially high concentration of the test substance - for example, animals used in an accumulation study. These animals are placed in sea-water containing no test compound and at intervals the level, C , of the compound in the tissue of a representative sample of the animals is measured. Ideally the animals should initially contain the equilibrium concentration of the test compound, but this is not necessary.

A schematic accumulation and elimination curve is shown in fig. 1.

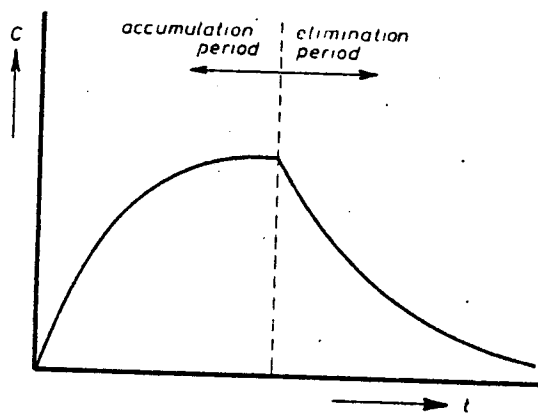

Fig. 1 Schematic accumulation/elimination curve for one concentration of the test compound in sea-water (C_w)

In general at least ten points are needed to plot such a curve. With a minimum number of animals per sample of 10 (see below, par. 3) and a wet weight of 0.5 g to 5 g per animal (weights used by members of the working group in the experiments of 1973-4), an initial biomass of the order of several hundred grams per experimental vessel is thus necessary at the start of an accumulation/elimination experiment.

The amount of sea-water necessary per day for this biomass is determined by both the amount of oxygen necessary and the fact that the uptake of the test compound by the experimental animals must not significantly effect the concentration in the water. Experience of these factors in toxicity tests has led to flow-rates between 1 l/g/24 h and 10 l/g/24 h (Alabaster and Abram 1965, Douderoff et al. 1951, EPA report 660/3-75-009 1975, Prevost et al. 1948). It seems reasonable that flow-rates of the same order of magnitude be used in accumulation/elimination studies.

If the test substance is not volatile the dissolved oxygen level can be maintained by aeration; the water replacement rate is then determined solely by the uptake of the test compound by the experimental animals. In cases where the accumulation is appreciable the water must be replaced several times a day; in these cases use of a continuous flow system is recommended. Discontinuous water replacement is indeed possible, but must be carried out once per 3-6 hours.

The principle of a continuous-flow system is shown in fig. 2. Several fully automatic systems for a constant and known flow-rate and a constant concentration of the test compound in the water are described in the literature on toxicity testing. For accumulation tests only those systems capable of handling a large volume of water (100-1000 l/d) can be considered; this is a consequence of the large biomass needed for these tests.

Systems that provide several different concentrations of the test compound at the same time (for example the system of Mount and Brungs, 1967) can only be recommended if it is required to carry out simultaneous accumulation tests with different concentrations of the test compound.

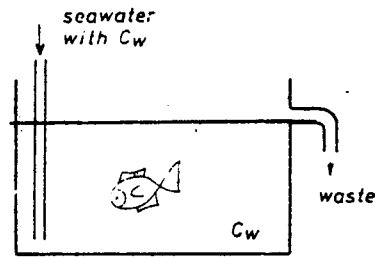

Fig. 2a Principle of continuous flow system during the accumulation period

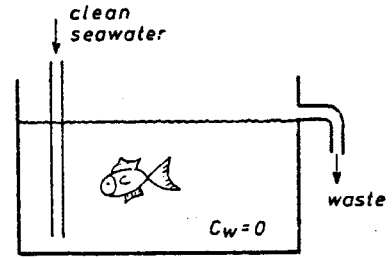

Fig. 2c Principle of continuous flow system during the elimination period

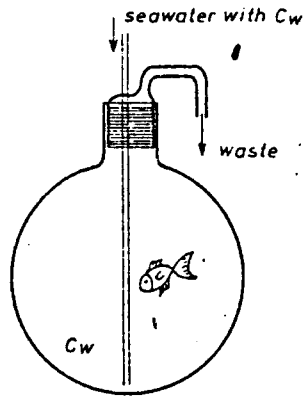

Fig. 2b Adaption, to be used with volatile test substances

The system of Connor and Wilson (1972) does not have this disadvantage, and can be used at any flow-rate. The concentration of the test compound in the different experimental vessels can be independently chosen and, by use of a suitable dosing-pump, either an aqueous or organic solution of the test compound can be used for dosing. In addition, the system is simple to construct and operate, although the use of electric dosing-pumps makes it susceptible to interference as a result of, for example, power failures.

Measurement at only one concentration is a minimum requirement to obtain an impression of the accumulation and elimination of the test compound. If a number of concentrations, covering a wide range, are used, the effect of C_w on the accumulation rate (A_r) and accumulation factor (A_f) can be measured.

If the saturation level in the tissue of the experimental animal is not reached and the animal exerts no active effect on the uptake and loss of the test compound, then the level in the tissue (C) will at all times be in proportion to the level in the water (C_w) (see fig. 3).

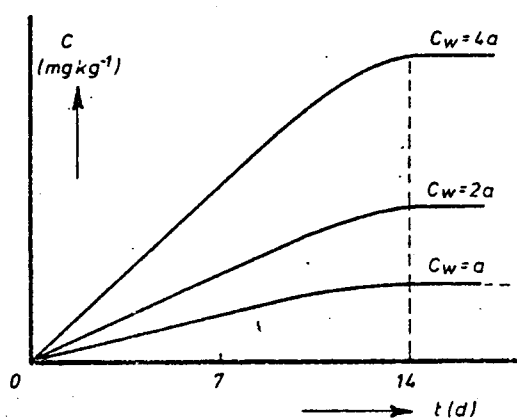

Fig. 3a Schematic acc/eli curve for 3 proportional concentrations of the test compound in sea-water

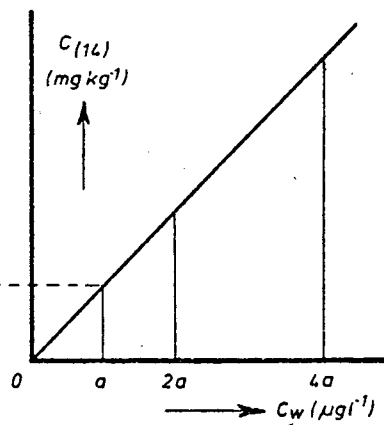

Fig. 3b Relation between C and C_w after 14 days of exposure, according to fig. 3a

For xenobiotic substances and uncontaminated animals, $C=0$ at $t=0$. In the absence of contamination $C=0$ for $C_w=0$ at all times. Concentrations that (i) are higher than the maximum solubility of the test compound, (ii) are sufficiently high to cause mortality in the experimental animal, or (iii) are too low to be measured in sea-water or biological tissue by chemical analysis, are not used. In order to measure the accumulation/elimination of a compound from/to sea-water in/from an animal, it is necessary that an analytical technique for the compound in sea-water and the relevant biological tissue is available. For analysis in biological tissue it is necessary that the compound can be extracted,

either quantitatively or with a known recovery, from the tissue. Definite information about recovery can only be obtained for pure substances; a model experiment is then carried out with radioactively labeled substance and the recovery of radioactive label compared with the results of the "ordinary" analysis.

If the accumulation/elimination of complex mixtures of incompletely defined composition is to be measured, it is generally only possible to measure the uptake and release of a number of components whose nature is known. Most of the problems encountered in accumulation/elimination work will be in the field of chemical analysis. Detailed protocols for these analyses cannot be given as the technique depends on the chemical nature of the experimental compound.

Model experiments with pure compound can, at least on a small scale, be carried out with advantage with radioactively labeled compounds.

As mentioned in the introduction, the 1975 Funchal meeting prepared a list of symbols and their definitions. This list, together with several other parameters, is given in table 1.

The use of these defined parameters is illustrated in fig. 4.

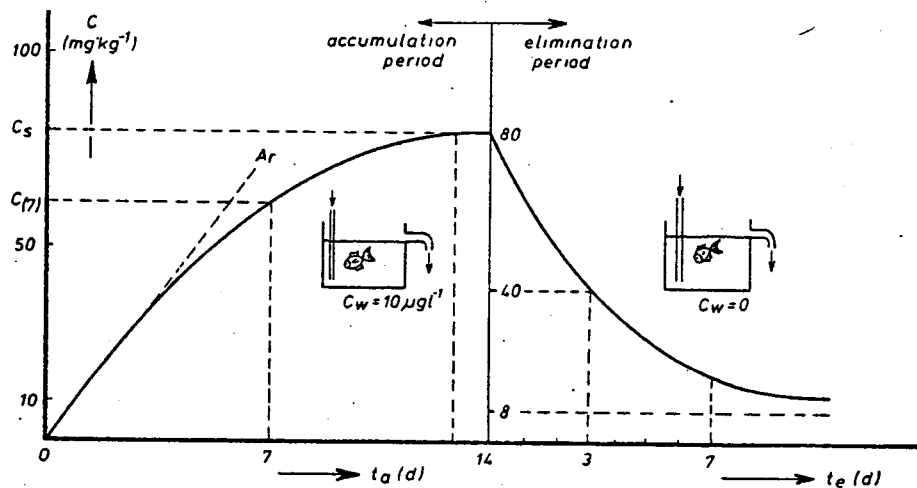

Fig. 4 Example of accumulation and elimination curve and demonstration of the terminology and symbols of table 1

$$t_p = 13 \text{ d}$$

$$C_7 = 62 \text{ mg kg}^{-1}$$

$$t_{e50} = 3 \text{ d}$$

$$C_s = 80 \text{ mg kg}^{-1}$$

$$C_f(7) = \frac{62 \text{ mg kg}^{-1}}{10 \text{ } \mu\text{g l}^{-1}} = 6200$$

$$t_{e90} = > 7 \text{ d}$$

$$A_f = \frac{C_s}{C_w} = \frac{80 \text{ mg kg}^{-1}}{10 \text{ } \mu\text{g l}^{-1}} = 8000$$

$$T_w = \frac{A_r}{C_w} = 1070 \frac{\text{ } \mu\text{g kg}^{-1} \text{ d}^{-1}}{\text{ } \mu\text{g l}^{-1}}$$

$$A_r = \left(\frac{dC}{dt} \right)_{t=0} = 10.7 \text{ mg kg}^{-1} \text{ d}^{-1}$$

Table 1 Symbols and units defined by the Funchal (1975) meeting

symbol	meaning	unit (for example)	notes
t	time	d	
t _a	accumulation time	d	
t _e	elimination time	d	
t _p	minimum time necessary to reach the plateau value during the accumulation period	d	
t _{e50}	elimination time necessary for C(t _e) = ½C(t _e =0)	d	
t _{e90}	elimination time necessary for C(t _e) = $\frac{1}{10}$ C(t _e =0)	d	
T _½	half life	d	independent of t _e and C
C _w	concentration of the test compound in the test vessel	µg.l ⁻¹	
\bar{C}_w	idem, mean over the experimental period	µg.l ⁻¹	
C(t)	level of the test compound in the organisms	µg.kg ⁻¹	dependent on t _a and \bar{C}_w
C _s	level of the test compound in the organisms on the plateau of the accumulation curve (steady state)	µg.kg ⁻¹	independent of t _a dependent on \bar{C}_w
A _r	initial accumulation rate $\left(\frac{dC}{dt}\right)_{t=0}$	µg.kg ⁻¹ d ⁻¹	dependent on \bar{C}_w
T _w	water transfer coefficient: A_r/\bar{C}_w	$\frac{\mu\text{g.kg}^{-1}\text{d}^{-1}}{\mu\text{g.l}^{-1}}$	may be assumed to be independent of \bar{C}_w
C _f (t _a)	concentration factor after t _a days accumulation: C(t _a)/ \bar{C}_w		dependent on t _a
A _f	accumulation factor on the plateau of the accumulation curve: C _s / \bar{C}_w		independent of t _a

3. GENERAL COMMENTS ON SUITABLE TEST ANIMALS

At the meetings of the biodegradation group experience with commercial crustaceans, commercial molluscs and commercial fish for accumulation and elimination work was described. These were chosen as experimental animals by the first meeting of the working group.

Shrimps appear not to accumulate any of the tested substances faster or to a higher level than mussels or fish, so the Funchal (1976) meeting decided to adopt one fish and one mollusc as the minimum requirement. As commercial mollusc, Mytilus edulis (or M. galloprovincialis) is recommended; this animal is easy to obtain at all times of the year and in all countries, it is of commercial importance and is known for its ability to accumulate many different substances.

The choice of a suitable fish is more difficult.

Commercial important fish are too large for a reasonable number of fish per sample, together with a reasonable number of samples per experimental vessel. Sticklebacks and guppies are suitable small fish that can be easily obtained everywhere and cultured in sea-water - also small locally occurring fish (such as Agonus cataphractus or Gobius microps) can be used. There is little information available about the number of animals per sample necessary; de Wolf (1970) used, for Mytilus edulis 30 randomly chosen mussels 30-35 mm long per sample. For toxicity testing it has been shown that then small trout (Alabaster and Abram 1965) or 30 minnows (Jensen 1970) are reasonable representative. In any case the number of animals per sample must be sufficient for analysis of the test compound in the biological tissue.

In order to keep the biomass per experimental vessel as low as possible, 10 individuals per sample has been chosen; in view of the above, this would seem to be a minimum requirement.

Despite the fact that analysis of the edible parts and the different organs is of practical and scientific interest, the working group decided that analysis of an homogenate of the whole animal was the minimum requirement. Additional measurement of the levels in different organs, particularly in the case of fish, is recommended.

Whether experimental animals should or should not to be fed during the accumulation and elimination period has not yet been decided. In general, the wet weight, dry weight and protein and fat levels must not change too much during the course of the experiment.

That the condition of the animals during the test must not seriously decline is obvious, however working with animals which are still growing rapidly can also give problems, as equilibrium states are not reached. With Mytilus edulis of 30-35 mm, an experiment of about 4 weeks duration can be carried out without feeding without serious weight loss. Most adult fish can be maintained at the initial weight by giving an appropriate quantity of food. If feeding is used, the food must be consumed within several seconds; otherwise the chance is great that the test substance will be taken up in the food - and, while this is also an interesting process, it is not the aim of the test described here.

4. DESCRIPTION OF THE TEST METHOD (MINIMUM REQUIREMENTS)

4.1 Materials

- At least two test vessels per test species, capacity preferably about 100 l, with a continuous flow system of capacity 100-1000 l/24 h.
- About 450 mussels with a length between 30-35 mm (or other test molluscs).
- About 450 small fish of a species with a wet weight of 0.5-5 g, the largest should not be more than 1½ times the length of the smallest of the batch.
- Natural, if necessary filtered, sea-water; salinity according to the requirements of the test animal and of a quality at least good enough to maintain cultures of Artemia salina 1).

1) See chronic test with Artemia salina.

- Thermoregulation system for the test vessels, according to the requirements of the test animal.
- aeration system to maintain the oxygen content of the sea-water near the saturation point (only necessary if the flow-rate or the water replacement frequency is not high enough to maintain the dissolved oxygen level).
- Oxygen, pH and salinity meters (or other measuring systems for these parameters).
- Alcohol thermometer.
- Homogenizer
- Ballance, accurate to 0.1 g.
- Knife for opening mussel shells.
- Flasks for storage of water and tissue samples.
- Fully equiped laboratory for analysis of test compounds.
- Deep freeze.

4.3 Determination of suitable concentrations of the test substance for accumulation/elimination tests

The solubility of the test compound in sea-water must first be determined; this concentration must not be exceeded.

Several weeks before the test is to be carried out sufficient animals for toxicity tests of the required size are collected and allowed to acclimatize for one week to the conditions (sea-water quality, temperature etc.) that are to be used in the test (these conditions must not differ too much from those prevailing at the collection site).

These animals must be of the same species and size as those later to be used in the accumulation/elimination tests. If the mortality during the acclimatization period is less than 10 %, the toxicity test can be carried out. The $LC_{50}^{96\text{ h}}$ of the test compound for the experimental

animals is determined, as is the background concentration of the test compound in "blank" (unexposed) animals. A test compound concentration is chosen that is (i) not higher than the maximum obtainable in seawater, (ii) at least three times the minimum detectable by the analytical technique used, (iii) about 0.01 of the $LC_{50}^{96 h}$ and (iv) in general, as low as analytically possible.

4.3 Selection of the experimental animals

Animals are collected and acclimatized as above (unused animals from the first collection can also be used, if these have been fed in storage). The mortality is again checked to be less than 10 % and the background level of the test compound measured in a sample of 10 animals - the compound should be undetectable, in other words at $t=0$, C must be $=0$. Mussels are selected so that the maximum size difference (see fig. 5) is not greater than 5 mm. Groups of 10 randomly selected mussels are placed in coarse mesh polythene nets (mesh about 1 cm) tied up with a thin thread. Fish are selected visually so that the size is approximately constant (fish are measured and/or weighed after the test, directly after taking of a sample).

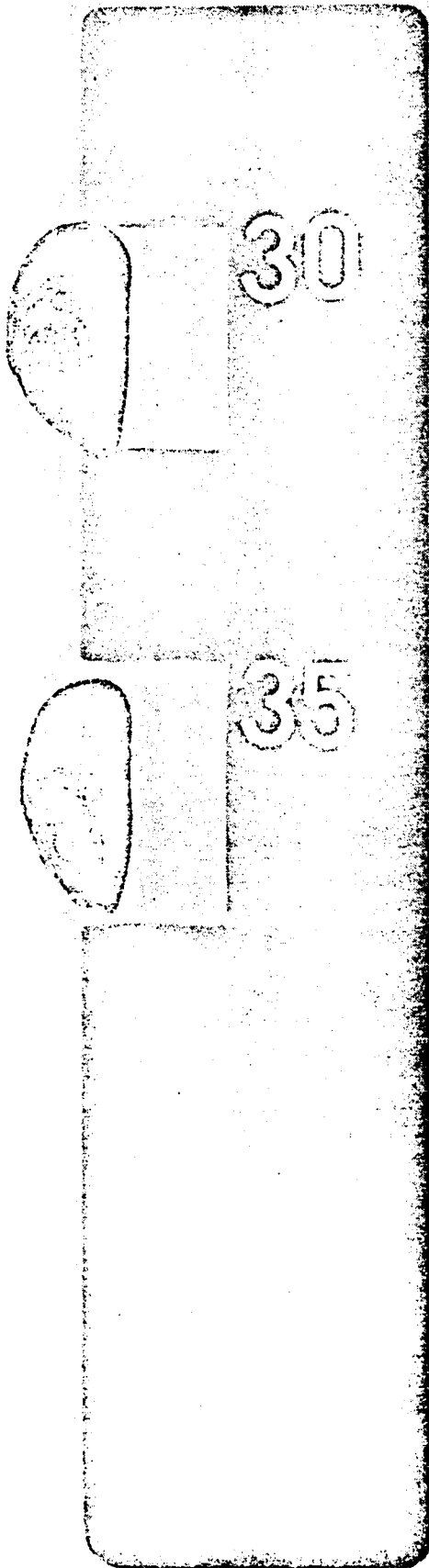

Fig.5 Easy method to select mussels, with greatest length between 30 and 35 mm. Each mussel, which fit in a hole of 35 mm and not in a hole of 30 mm, has a greatest length between 30 and 35 mm.

4.4 Preparation of the test vessels

For each species of test animal, one test vessel of about 100 l is prepared as blank, and the other with the appropriate concentration of the test compound.

If the test compound is volatile, or codistils with water, the test vessels cannot be aerated, In this case the water replacement rate must be sufficiently high to maintain an adequate dissolved oxygen level in the test vessel - about 5-10 l water per gram biomass per 24 hours. At such a flow-rate also the concentration of the vast majority of possible test compounds in the test vessel will remain constant. If aeration is carried out, then utilization of the test compound becomes the deciding factor in determination of the water replacement rate. For compounds that only accumulate to a very small extent, a replacement rate of 1 l/g biomass/24 h will often be sufficient, but for compounds that are more rapidly accumulated a rate of 3-5 l/g biomass/24 h will be necessary. This sort of flow-rate is a much used average for substances for which no detailed information is available in advance.

The system is first run for 24 h (longer if necessary) without experimental animals to stabilise the concentration of the test compound in the test vessels and other apparatus. When the concentration has stabilised at the required value as measured by analysis the test proper can begin.

4.5 Execution of the accumulation/elimination experiment

At $t=0$ 120 animals are added to each test vessel. Throughout the test the concentration of the test compound in the sea-water is measured daily to three times per week. The oxygen level, pH, temperature and salinity are also checked daily. During the accumulation period, samples of 10 animals are taken on days 1, 2, 4, 8 and 14 (2 samples) from each test vessel.

The mussels are cut open and the two halves allowed to drain upside down for one minute. The flesh is removed from the shells and placed in a coded, pre-weighed, tightly closable glass container. The wet weight is determined and the container placed in a deep-freeze.

Ten fish are caught in a coarse mesh nylon net and allowed to drain for one minute. The fish are individually measured and/or weighed and together placed in a coded, pre-weighed, tightly closable glass container. The total weight is determined and the container placed in a deep-freeze.

After taking the samples on the 14th day the vessels containing the test compound are syphoned empty and filled with fresh sea-water. They are then connected to a continuous flow system with fresh sea-water or discontinuously refilled. If desired, the test vessels can be aerated.

The concentration of the test compound in the sea-water is still measured - this must be low and decrease even further with time; as a result of release of the test compound from the experimental animals and the apparatus this level will not be immediately below the detectability limit.

Samples of 10 animals are taken after 1, 2, 4 and 7 days (2 samples) and handled in the same way as those taken during the accumulation phase.

Just prior to analysis the samples are thawed out in a refrigerator and well homogenised (individual parts must not be distinguishable). The quantity necessary for analysis is weighed out twice - each homogenate is analysed in duplicate, thus for $t_a = 14$ d and $t_e = 7$ d four analyses are carried out, for the other days two. The remaining homogenate is refrozen, in case the analysis must be repeated.

The analyses are carried out as soon after sample-taking as possible - if the samples have been stored in the deep-freeze the effect of this storage on the analyses must be checked.

If required, some or all of the samples can be analysed for dry weight/wet weight ratio and the fat and protein levels. Standard techniques are used for these analyses.

5. HANDLING OF THE RESULTS

The mean concentration (\bar{C}_w) of the test compound in the sea-water during the accumulation period is calculated and recorded, together with its standard deviation.

The mean values throughout the test of the temperature, pH, salinity and dissolved oxygen level are also calculated and recorded - a special note must be made of any exceptionally high or low values for these parameters.

As long as the difference of the two duplicates from their mean is less than 10 %, the mean level of the test compound, \bar{C} , per unit wet weight in the experimental animals is calculated and recorded. If the difference from the mean is greater than 10 % then the homogenization and analysis of these samples must be repeated.

An accumulation/elimination curve (as in fig. 4) is then drawn and, as far as possible, the values of the different parameters calculated.

The ratio dry weight/wet weight and the fat and protein levels are recorded for those samples in which these parameters were measured. If required, accumulation/elimination curves can also be plotted per unit dry weight and per unit fat content.

The analysis techniques used for the test compounds in sea-water and biological tissue are recorded, also the techniques used for the determination of dry weight and fat and protein content.

6. LITERATURE

Alabaster, J.S. and F.S.H. Abram (1965): Development and use of a direct method of evaluating toxicity to fish.
Proc. 2^{ed} Int. Water Poll. Res. Conf. Tokyo 1964, 41-60.

Connor, P.M. and K.W. Wilson (1972): A continuous-flow apparatus for assessing the toxicity of substances to marine animals.
J. Exp. Mar. Biol. Ecol. 9, 209-215.

Douderoff, e.a. (1951): Bio-assay methods for toxicity to fish.
Sewage and Ind. Wastes 23 (11), 1380-1397.

EPA report 660/3-75-009 (1975): Methods for acute toxicity tests with fish, macroinvertebrates and amphibians.

Jensen, A.L. (1972): Standard error of LC50 and samples size in fish bioassays.
Water Res., Perg. Press 6, 85-89.

Mount, D.I. and W.A. Brungs (1967): A simplified dosing apparatus for fish toxicology studies.
Water Res., Perg. Press 1, 21-29.

Prevost, C. ed. (1948): Effect of volume on the determination of DDT and Rotenone toxicity on fish.
J. Wildlife Management 12 (3), 241-250.

De Wolf, P. and W.E. Lewis (1972): Een meetnet voor zware metalen langs de Nederlandse kust.
TNO-nieuws 27, 504-510.

CONVENTION FOR THE PREVENTION OF MARINE POLLUTION BY DUMPING FROM
SHIPS AND AIRCRAFT

SEVENTH MEETING OF THE STANDING ADVISORY COMMITTEE FOR SCIENTIFIC ADVISE

HAMBURG: 2 - 5 OCTOBER 1979

Test Procedures

Comments of the Federal Republic of Germany on Test
Procedures under the "Prior Consultation Procedure"

Agenda item: 11

Presented by: Federal Republic of Germany

Test Procedures.

Comments of the Federal Republic of Germany of Test Procedures under the "Prior Consultation Procedure"

Preliminary remarks

Biotests for the assessment of the toxicity of wastes have been carried out for a long time in fresh water and seawater. Many well-established procedures can be taken from the following literature: - Tarzwell 1962; Sprague 1969 a.b., 1971; EPA 1975, 1976; ASTM 1970; Mount 1977; Kimerler et al., 1978; FAO 1976, 1977; Brungs and Mount 1978; Brungs 1973; Stephan and Mount 1973.

Some of the testing procedures now suggested were discussed during the 6th SACSA meeting (19th to 22nd September, 1978).

In connection with the implementation of authorization procedures for the dumping of wastes at sea, biotests have also been used repeatedly in the Federal Republic of Germany and have been used in the decision-making process. Especially in the case of applications to dump wastes from the titan dioxide industry (diluted acids), bauxite processing (red mud), and asbestos manufacture, numerous investigations have been carried out during the past years, using biotests. Consequently, we agree generally with the choice of a limited number of tests for use within the framework of the permission procedure. Hitherto, difficulties have arisen in the effort to standardize the test procedures used to date. Thereby the following reasons are decisive: -

- 1 Most of the test procedures used are developed for investigations of special scientific purpose.
- 2 They are almost exclusively adapted to the equipment of the laboratory where the test procedure was developed. Therefore, they are not coordinated to a serve in routine operation.
- 3 They mostly do not follow a uniform interpretation scheme for a standard statistical evaluation.

- 4 As a rule, they are expensive, at the same time requiring special knowledge and experience and, therefore, cannot be practiced by every laboratory.
- 5 In part, they are designed for organisms (or rather, their juvenile stages) which are only available during a relatively short period in the year.
- 6 In part, they are designed as extensive long-term tests, and are far beyond the scope required here.

It is true that, as a rule, long-term tests yield useful results and permit the use of sensitive criteria; however, they are too expensive and complicated in their realization and - for practical reasons - are not to be promoted as standard procedures. Their realization, in the same way as with other procedures using sensitive organisms, should only be called for if the results aimed at from the standard methods recommended here do not lead to any clear cut decisive finding. However, such investigations can then only be carried out by scientific institutions. They should also ascertain the requisite application factor from case to case.

In our considerations concerning the evaluation and the suggested testing procedures, and in the search for suggestions for improvements and alternatives, we have based them upon the following criteria : -

- 1 Test organisms should be of marine origin.
- 2 They are not necessarily to be taken from the dumping ground under consideration.
- 3 Test organisms should be adequately sensitive, but do not need to be of commercial interest.
- 4 They must not necessarily be available for the whole of the year (as a rule, authorization procedures extend over six months and longer).
- 5 The test procedure used should provide reproducible results, and - for that reason - must be carried out with (a) standard (defined) test objects, and (b) using a method which is described in detail.

Statement concerning the suggested testing procedures

In total, six biotests have been suggested : -

- (a) Artemia test
- (b) Accumulation and elimination test
- (c) Recovery test
- (d) Inhibition of growth of phytoplankton
- (e) Determination of the degradability of organic compounds: Die-away test
- (f) Acute toxicity tests

As concerns (a): Artemia test

The Artemia test was originally developed by the TNO for bio-accumulation tests with radio isotopes. The Netherlands, for some time past, standardized culture technique had been developed for this purpose, which guaranteed a relatively simple application. Nevertheless, several reasons argue against the use of Artemia for toxicity tests in short-term investigations. Artemia is relatively insensitive and must be viewed as a non-typical organism as far as North Sea conditions are concerned. In addition, Artemia react differently in accordance with their origin. Therefore, a purely marine species with adequate sensitivity is to be given preference, in every case, as test organism. The EPA in their Guidelines also require marine organisms as test objects. The Federal Republic of Germany rejects the Artemia test as being unsuitable.

The Federal Republic of Germany suggests the Hydroid test (Annex III) as an alternative to the Artemia test. In England, good results have also been attained with hydroids (e.g. Stebbing). The advantage of hydroids results from the possibility to utilize genetically uniform material

(Standard clone) which can be easily distributed to all laboratories in the Convention area. This would allow to obtain reproducible results with a sensitive organism which can be easily handled. Moreover, at the present time, Hydroid cultures are being tested for future employment in the so-called "effects monitoring" and have also proved themselves to be reliable objects for that purpose.

As concerns (b): Accumulation and Elimination test

In principle, there is nothing to be said against the accumulation and elimination test. However, it appears to be over-dimensionalized, and expensive. In addition, it is unsuitable for testing substances of low solubility or those which are volatile. One is also reminded to a parallel development presently discussed by OECD (Annex IV). A coordination with the test procedure suggested there would appear to be useful.

Some remarks to several details contained in the description of the test, should be pointed out :

- Considering the number of test animals, the required O_2 -content in the test medium (unaerated), as well as the O_2 -consumption of the test animals, a total of a $6 \text{ m}^3/\text{d}$ of water will be necessary to utilize per test. This results, with a continuous additional dosing of the test substances, not only in a considerable consumption of chemicals but also signifies an increased contamination risk in the immediate vicinity of the laboratory carrying out the investigations. Decontamination installations would be large-scale and expensive.*

* Example for calculating the water consumption per day: -

$$120 \text{ animals (min. } 0.5 \text{ g soft body)} \times \text{min } 1 \text{ l/g/d} = 60 \text{ l}$$

$$120 \text{ animals (max. } 5.0 \text{ g soft body)} \times \text{max } 10 \text{ l/g/d} = 6000 \text{ l}$$

It is suggested that the procedure - with reference to the test discussed at the OECD (Annex IV) chemicals testing group - be modified and supplemented as follows: -

- 1 The actual concentration of the test substance must always be analytically followed in the culture medium over the whole of the test period, when the substance to be tested is soluble in all the concentration steps to be examined. For the accumulation test it is then also sufficient to continuously follow, in a static procedure, the loss in the water and to determine only once the absorption in the organism at the end of the experiment.
- 2 One must proceed upon the assumption that an elimination test is not always to be incorporated in all cases. In general, both should not be required with the exception of substances which are orally administered only.
- 3 In case the accumulation test cannot be carried out satisfactorily owing to the low solubility or the extreme volatility of the substance to be tested, the elimination test can be considered as the most suitable procedure (example: PCB elimination after oral application; Goerke and Ernst 1977, Goerke 1979).
- 4 Nereis virens. Nereis diversicolor.
Plathychthis flesus and Solea solea
are suitable test organisms, especially in case the absorption of the substance must be determined via the intake of contaminated food.

5 *Mytilus edulis* can be considered as a highly suitable test organism when dissolved contaminants are used for the accumulation test. Some remarks are given below with regard to the suggested procedure :

- Mussels should belong to a uniform size class (see ICES Recommendation: 4.0 - 4.5 cm shell length).
- Mussels should not only be opened by cutting the adductor muscle (see Adema D 76/88, Page 14, line 1), but the mantle (pallium) should also be detached from the shell, so that the water can drain off from the gill-mantle chamber.
- The concentration factor should always be related to the wet weight.
- Mussels should be fed during the tests, if the tests are carried out in accordance with the procedure suggested by Adema (D 76/88) in order to avoid unnecessary stress during a testing period of four weeks.

The feeding should take place daily for a brief period of about 30 minutes. The mussels which are collected in a net should be transferred into a feeding basin containing algae in suspension.

During the elimination test, they can be fed direct and continuously. The algae cultures used should be maintained at comparable cell densities.

Following the procedure suggested by Dr. Ernst (*Mytilus*), the feeding of the test animals is advised only during the acclimatization phase prior the actual tests. Faeces or pseudo-faeces can possibly represent a disturbance factor during the test as they can act as a depôt of the test substance.

Usually, one can expect that time required to reach an equilibrium will not exceed much more than eight days. In that case feeding during the actual test is not necessary.

- As a rule, the assessment of the absorption would be sufficient from the determination in the whole animal. In specific cases, it is desirable - for the assessment - to draw upon the very different storage capacity of individual organs. For that, in the case of the edible muscle, the mid-gut gland, the kidney, mantle, and adductor are suggested. In the case of the use of the sole as test organism: the liver and muscle tissue.
- In accordance with the paper in question it was suggested that at time zero the test substance in the animal should also be zero. In many cases this is not possible, since there is already a basic burden for many substances present in sea water (e.g. heavy metals).
- The common mussel should not be used during the period between February and May, because this is their spawning period. In any case, it should be guaranteed that the test animals have spawned before the test is commenced. This can be attained by increasing the temperature of the culture medium. The condition index should be registered, in order to document seasonal differences.
- Reference chemicals are recommended for inclusion into the bio-accumulation test (Reference to the Jülich Working Group: Reference chemicals.).

- In the accumulation test, the test equipment (especially the holding vessels) - owing to the absorption behaviour of different test substances - should not be made of plastic but should be glass. Hence, for the holding and shifting of *Mytilus* no plastic net should be used (e.g. in the case of organochlorine compounds: stainless steel basket).

As concerns (c): Recovery test

The ability of the recovery test to make a scientific statement is viewed as being of low relevance, therefore, considered as not suitable.

Very few substances only manifest their effects within such a short exposure time, as suggested in the proposal.

As concerns (d): Inhibition of growth of phytoplankton

The carrying out of an algae test is agreed to in general; nevertheless, not all the species suggested should be used. Preferably, in each case, a diatom or a flagellate should be used. The species Tetraselmis is viewed as being unsuitable, because it sticks severely to the walls and thereby high experimental errors could occur. The diatom *Phaeodactylum* is rejected as being extremely non-typical, especially as it is very weakly silicious. Moreover, the question of whether genetical or physiological development types could be accepted is unanswered.

Dunaliella is certainly relatively insensitive; however, is easy to handle, can be well utilized as food organism for the accumulation test, but is unsuitable for toxicity testing.

The use of natural seawater as a culture medium has disadvantages. Artificial seawater offers the advantage of standardizability (intercalibration). Nevertheless, we suggest the utilization of natural seawater, because artificial seawater offers no optimum growth conditions for many of the test algae; especially the species which are considered to be sensitive can be cultivated in artificial seawater only with difficulty or not at all and, from the very beginning, make a test impossible. It is suggested that natural, sterile filtered seawater, taken from the place intended for dumping, be used for the algae test. If necessary, the seawater must be enriched with nutrients in order to enable the test algae, used in the control test, to attain growth with measureable cell density. Sterile filtering of seawater is applicable, because sterilization by heat leads to precipitations thereby altering the composition of seawater. In addition to the cell density, determination with the Coulter counter or the counting microscope, we consider that the determination of the chlorophyll content (fluorometer), the measurement of the $^{14}\text{CO}_2$ absorption, or the oxygen production may be feasible. Morphological changes in the cells should be particularly taken into account.

As concerns (e): Determination of the degradability of organic compounds; Die-away test

The necessity of carrying out these tests is recognized. Their application should take place in the marine environment, although it would be fundamentally possible to carry them out in fresh water also. More exact definition of the test requirements appears to be necessary because these are decisive for the degradability. Above all, the temperature required appears to be too high. Thereby, one turns away further from natural conditions than necessary.

It is also doubted that the use of natural mixed populations leads to reproducible results. In static tests, one would be unable or hardly able to maintain them in their original composition. The standardizability of the procedure is thereby subject to question. At all events, to maintain mixed populations would be feasible in a continuous culture procedure only; nevertheless, the expense would be unjustifiably high. Therefore, it is suggested that a pure population should be used, as suggested by Tan (Annex I) for toxicity testing with bacteria. The question of the substrate concentration is not yet optimally solved. However, one must realize that practical reasons compel the use of higher substrate concentrations.

As concerns (f): Acute toxicity tests

We agree with general tendency of the paper to define certain basic minimum requirements of test procedures. Concerning the choice of species it seems not always be forced to use a representative of molluscs, crustacea and fish. It should also be acceptable to use two different invertebrate species, one of them not necessarily belonging to the phylum of molluscs or crustacea. However, fish should always be included in the acute toxicity test. Flatfishes are recommended because they are relatively easy to handle.

In any case, we are not in favour of using Artemia salina as test organism (see comments to (a)).

Closing remarks

Whatever test procedure one will decide upon as being the standard procedure, it should not be looked upon as being exclusive. At present, several procedures are being tried out, which are also to be employed within the framework of effects monitoring.

To these belong - amongst others - the test procedure using sea urchin eggs, as is already being used by the Japanese. Furthermore, at present, there is the possibility of using Palaemon - a small shrimp - as sensitive test organism in standardized toxicity tests in which sublethal effects are considered to be the criteria. Furthermore, one is reminded of the very sensitive American tests using the juvenile stages of oysters, which have proved to be useful. Therefore, from the very beginning, one should keep open the long-term possibility of being flexible and able to revise this catalogue of procedures from time to time.

Several alternative test procedures included in Annexes 1 to 4 are herewith introduced by the Federal Republic of Germany for further discussion.

23rd August, 1979.

Annexes:

- | | | |
|-----|---|-------------|
| I | Toxicity test using bacteria. | (T.L. Tan) |
| II | Toxicity test using cultures of marine planktonic algae. | (H. Kayser) |
| III | Chronic toxicity test using clonal marine hydroids. | (L. Karbe) |
| IV | Bioaccumulation testing with the common mussel, <u>Mytilus edulis</u> . | (W. Ernst) |

Toxicological tests with bacteria

T. L. Tan

Institut für Meeresforschung Bremerhaven

Introduction

The toxicological test is based on damage to growth and/or the metabolic activity of a cadmium-sensitive bacterium *Acinetobacter* sp. in artificial seawater under the influence of harmful substances. The micro-organism can be cultivated in freshwater or seawater broth, and good growth can be achieved in salinities between 10⁰/∞ and 17⁰/∞.

For estimation of growth inhibition the following biomass determinations can be used:

1. Viable cell counts on solid medium (ASWA)
2. Staining the cells with acridine orange and counting under the epifluorescence microscope
3. ATP contents of the bacteria

To determine the deterioration of metabolic activity the decrease of glucose concentration in the nutrient broth can be followed, because glucose is the sole carbon source for the bacterium.

Morphological alterations of the cells under Cd influence have already been observed. Usually, small rods occur singly or in chains of 2-4 cells, but pleomorphic and long filamentous cells have been noticed under Cd influence.

The bacteria can be cultivated in shake flasks (batch cultures) or in chemostats (continuous cultures). Both methods are qualified to determine the lethal or sub-lethal effect of a toxicant. When grown in the chemostat, besides glucose concentrations glucose uptake kinetics with ¹⁴C-glucose as substrate and adenylate energy charge measurements, i.e. $\frac{(ATP) + 1/2 (ADP)}{(ATP + ADP + AMP)}$, in the effluent of the culture can be used to determine the deterioration of the metabolic activity.

Maintenance of the strain

Acinetobacter sp. strain CS 13 is cultivated on ASWA agar slants and stored at +4° C. Every 6 - 8 weeks the cultures are inoculated on fresh media. Besides these cultures vacuum-dried cultures are also maintained.

Performance of batch cultures

The bacteria are grown in shake cultures in 100 ml nutrient broth (see appendix) in a 500 ml Erlenmeyerflask with incisions (e.g. Bellco) at 24° C. To inoculate the nutrient broth two precultures are needed:

First preculture: From an agar slant a loopful of bacteria is inoculated into 5 ml of nutrient broth (test tube) and incubated at 24° C for 24 hours.

Second preculture: 5 ml of nutrient broth in a test tube is inoculated with one drop of the first preculture and incubated at 24° C for 24 hours.

The sewage to be examined is first sterilized in an autoclave or by filtration through 0.2 µm membrane filter. Subsequently a serial dilution of the sterile sewage is made in double distilled water. To each 100 ml of nutrient broth 1 ml of the original sewage or of the several dilutions is added and the nutrient broth is then inoculated with 5 ml of the second preculture. At least 3 flasks are inoculated for each sewage dilution and for the control to calculate the mean value and the standard deviation of the method.

Growth curves are drawn up by recording the bacterial densities during an incubation time of 24 hours. Inhibition of growth is evaluated by comparing the duration of lag-phase, generation time and cell yield of the bacterial population in nutrient broth with sewage addition and in the control culture. The course of the glucose decrease can also be used as a measurement of toxicity. The acridine orange staining and counting of the cells under the epifluorescence microscope is recommended, since morphological deviations can be identified simultaneously.

Performance of continuous cultures

The fermentor is a 1000 ml wide-neck vessel with flat teflon cover (e.g. E. Schütt jr., Göttingen). The vessel is put into a plexi-glass jacket and the jacket connected to a thermostat set at a temperature of 24° C. The working volume of the fermentor is 300 ml. A homogeneous distribution of cells is achieved by magnetic stirring. A slight excess pressure is formed by introducing sterile air (5-6 l hr⁻¹) into the fermentor, which simultaneously protects against contamination. The nutrient broth (see appendix), also magnetically stirred, is transported from the reservoir (10 l flask) to the fermentor by means of a peristaltic pump. A second peristaltic pump, adjusted to a higher speed than the first pump, regulates the working volume of the culture. The bacteria from the culture are harvested in an effluent bottle (5 l) at 20° C in a water bath.

The nutrient broth in the culture vessel is inoculated with 15 ml of the second preculture and at a dilution rate (D) of 0.05 hr⁻¹ a steady state is already reached after 24 hours (1 - 2.10⁸ cells ml⁻¹). The saturation constant (K_S) of the bacteria is about 1 mg glucose l⁻¹ (glucose is the growth-limiting factor) and the maximum growth rate (μ_{\max}) is 0.225 hr⁻¹. The influence of sewage upon the bacterial population can be determined by continuous feeding of the sewage (or appropriate dilutions) separately from the nutrient flow into the culture vessel. Cell density, glucose concentration, uptake of ¹⁴C-glucose and adenylate energy charge can be determined in the effluent at 24 hours interval.

Another application is to cultivate the bacteria in continuous culture to gain a uniform cell material for short-term toxicological tests, e.g. by measurements of ¹⁴C-glucose uptake or adenylate energy charge.

Literature

Albright, J.E. and E.M. Wilson (1974): Sub-lethal effects of several metallic salts-organic compounds combinations upon the heterotrophic microflora of a natural water. *Wat. Res.* 8, 101-105.

Falkowski, P.G. (1977): The adenylate energy charge in marine phytoplankton: The effect of temperature on the physiological state of *Skeletonema costatum* (Grev.) Cleve. *J. exp. mar. Biol. Ecol.* 27, 37-45.

Hobbie, J.E., R.J. Daley and S. Jasper (1977): Use of nuclepore filters for counting bacteria by fluorescence microscopy. *Appl. Environ. Microbiol.* 33, 1225-1228.

Karl, D.M. and O. Holm-Hansen (1977): Adenylate energy charge measurements in natural seawater and sediment samples, pp. 141-169. In: G.A. Borun (ed.). *ATP methodology seminar*, SAI Tech. Co., San Diego, California.

Tan, T.L.: Sublethal effects of $CdCl_2$ on *Acinetobacter* sp. in continuous cultures. Paper presented at the 4th International Symposium on Environmental Biogeochemistry. Canberra, 26-31 August, 1979.

Thormann, D. (1975): Über die Wirkung von Cadmium und Blei auf die natürliche heterotrophe Bakterienflora im Brackwasser des Weser-Ästuars. *Veröff. Inst. Meeresforsch. Bremerh.* 15, 237-267.

Thormann, D. und H. Weyland (1979): Beziehungen zwischen den Eigenschaften unterschiedlicher Brackwasser- und Meeresbakterien und der wachstumshemmenden Wirkung von Cadmium und Blei. *Veröff. Inst. Meeresforsch. Bremerh.* 17, 163-188.

A p p e n d i x

Artificial Seawater Agar (ASWA)

Peptone	5.0 g
Yeast extract	1.0 g
Fe (III) PO ₄ · 4 H ₂ O	0.01 g
Agar (E. Merck)	12.0 g
Artificial seawater	1000 ml

If necessary, the pH is adjusted to 7.6 with 1 N HCl or 1 N NaOH.

Fill in test tubes to 10 ml portions and sterilize in the autoclave.

Solution I

NaCl	11.738 g
KCl	0.332 g
KBr	0.048 g
MgCl ₂ · 6H ₂ O	5.305 g
SrCl ₂ · 2 H ₂ O	0.020 g
CaCl ₂ · 2 H ₂ O	0.734 g
Double distilled water	500 ml

Solution II

Na ₂ SO ₄	1.958 g
NaHCO ₃	0.096 g
H ₃ BO ₃	0.013 g
Double distilled water	500 ml

Artificial Seawater, 17^o/∞ Salinity

Solution II is poured into the stirred Solution I

Solution III

NaCl	11.738 g
KCl	0.332 g
KBr	0.048 g
MgCl ₂ ·6H ₂ O	5.305 g
SrCl ₂ ·6H ₂ O	0.020 g
CaCl ₂ ·2H ₂ O	0.734 g
(NH ₄) ₂ SO ₄	0.050 g
D(+)-glucose	0.100 g
Tris-(Hydroxymethyl)-aminomethane	0.125 g
Double distilled water	488 ml

Solution IV

K ₂ HPO ₄	20 mg
Double distilled water	10 ml

Solution V

FeSO ₄ ·(NH ₄) ₂ SO ₄ ·6H ₂ O	3.0 g
MnSO ₄ ·1H ₂ O	0.08 g
0.01 N H ₂ SO ₄	1000 ml

The solution is sterilized in the autoclave.

Solution VI

p-Aminobenzoic acid	100 mg
Thiaminedichloride	500 mg
Calcium-D(+)-Pantothenic acid	500 mg
Vitamin B ₁₂	1 mg
Double distilled water	1000 ml

The solution is sterilized by filtering through 0.2 μm membrane filter.

Solution VII

D(+)-Biotin	2 mg
Folic acid	1 mg
Riboflavin	50 mg
Double distilled water	1000 ml

The solution is sterilized by filtering through 0.2 μ m membrane filter.

Nutrient solution for precultures and batch cultures

Solution II (500 ml) + Solution III (488 ml) +
Solution IV (10 ml) + Solution V^x (0,4 ml) +
Solution VI (1 ml) + Solution VII (1 ml)

If necessary, the pH is adjusted to 8.0 with 1 N HCl or 1 N NaOH.

The prepared solution is sterilized by filtering through 0.2 μ m membrane filter.

Nutrient solution for continuous cultures

Solution II (500 ml) + Solution III, only with 0.040 g
glucose (488 ml) + Solution IV (10 ml) +
Solution V^x (0,1 ml) + Solution VI (1 ml) +
Solution VII (1 ml)

If necessary, the pH is adjusted to 8.0 with 1 N HCl or 1 N NaOH.

The prepared solution is sterilized by filtering through 0.2 μ m membrane filter.

^x Solution V is added to the nutrient solution before use.

Toxicity test with marine planktonic algae

H. Kayser

Biologische Anstalt Helgoland (Litoralstation)
D - 2282 List, Sylt, Federal Republic of Germany

Introduction and scope

The algal test is based on the cultivation of marine planktonic algae in the laboratory exposed to increasing amounts of wastes or waste products added to the culturing medium. Inhibition of the division rate, cell production, "in vivo"-chlorophyll fluorescence and morphological alterations of the cells have been selected as criteria of sublethal effects on the organisms. Besides the determination of sublethal and lethal toxicity thresholds of toxic waste products the method also permits to determine eutrophicating effects of domestic sewages.

In order to be able to extrapolate the results of such laboratory experiments to natural environmental conditions only such species should be chosen, which are characteristic of the areas which will be considered for the discharge of wastes. Furthermore, the species should be sensitive and give no problems in routine culturing. Sterile filtered seawater from the areas which are considered for waste discharges, should be used for all the experiments preferably without enrichment with nutrients, trace elements, vitamins and chelators, in order (1) to avoid as much as possible indirect growth enhancement of the test algae by the nutrients added, and (2) to avoid chemical reactions of the added waste water components with the nutritive medium. The following test species have proved to be interesting candidates with regard to the North Sea:

- Dinophyta: *Prorocentrum micans*
Gymnodinium splendens
Scrippsiella faeroense (previously: *Peridinium trochoideum*)
- Diatoms: *Chaetoceros socialis*
Coscinodiscus granii
- Haptophyceae: *Phacocystis poucheti*

The cultures were kept unialgal but not axenic. The testing procedure can be carried out in two different ways:

- (1) Batch culture
- (2) Continuous culture (Turbidostat principle)

Interferences:

The control cultures of different experimental series can show different growth response during the course of a year. This is quite understandable since the tests are carried out with natural seawater which is undergoing seasonal and local variations. The same is true for seasonal variations of the physiological condition of the algal cultures. The results provide, therefore, in the first place a relative expression of the effect of waste water in comparison with the control cultures. This fact, however, cannot be considered as an intrinsic weakness of the test method because the same varying factors are occurring as well in the natural environment.

Part I. : Batch culture test

The algae are inoculated in a series of test bottles in relatively low initial cell densities. Addition of waste water in increasing concentrations is carried out once, at the start of the experiments. The growth of the cultures is measured during the exponential phase up to maximum cell densities by daily counting of the cell numbers and determination of the "in vivo" chlorophyll fluorescence. Morphological aberrations are assessed by microscopical analysis. The test permits the relatively fast determination of sublethal and lethal toxicity thresholds of waste waters within the time span of the batch culture period which amounts to about 1 week in fast growing species and about 4 weeks with relatively slow dividing algae.

Materials

5- and 10 l glass bottles (Jenaer Glass, DURAN 50 or G 20).

Membrane filters of 0.2 μ m pore diameter to sterilize the seawater.

Autoclave to sterilize glass ware.

Daylight fluorescent tubes (for example Osram- L40 W/50).

Time switch clocks for night-day photoperiods.

Temperature constant rooms at 18 °C.

Inverted microscope or Coulter counter equipment.

"In-vivo" fluorimeter.

Chemicals:

- (1) Na NO₃ p.a., Na H₂ PO₄ · H₂O p.a. (and Silicate for diatoms)
- (2) f/2 medium nutrients for stock cultures after a recipe of Guillard & Ryther (1962).
- (3) Lugol-solution for microscopic counting.

Experimental procedure

- (1) The tests are performed in temperature constant rooms at about 18 °C. The cultures are illuminated by fluorescent lamps situated along side the culturing vessels at a distance of 10 cm. The illumination is kept at a night:day cycle of 10:14 h and at a light intensity of about 3,000 Lux.
- (2) Stock cultures are kept in f/2 medium.
- (3) Test algae are brought in filtered seawater which has to be enriched for some species with 0.075 g l⁻¹ Na NO₃ + 0.005 g l⁻¹ Na H₂ PO₄ · H₂O . (for diatoms silicate has to be added too)

In order to avoid the transfer of f/2 nutrients into the test medium, test cultures have to be preadapted for at least 1 batch culture period in the above mentioned medium. Inoculation has to be made from cultures during the exponential¹⁾ growth phase. Waste water is added to the test cultures at the start of the experiments in amounts which are expected to cover the range of both sublethal and lethal effects. If necessary the experiments have to be repeated with other dilutions. In order to obtain significant results experiments should be carried out at least in five duplicates. The analyses are stopped when the cultures have reached maximum cell densities.

Part II : Continuous culture test

The algae of the control series are kept at a constant cell density in the exponential growth phase by means of a continuous flow through of the culture medium. The flow rate is dependent of the multiplication rate of the cells and can be calculated from the formula $V = k \cdot Vol$ (V = pump velocity in ml/day, k = relative growth constant of all algal species, Vol = experimental volume in 10³ ml; k can be calculated from the slope of the growth curve of a batch culture during exponential phase and can be calculated from the formula $\frac{dN}{dt} = k \cdot N(t)$; $\frac{dN}{dt}$ is the growth velocity of the culture and N(t) the number of cells at time t). The flow rate can be determined also empirically by a precise regulation of the pump velocity.

In series with addition of waste water the same flow rate has to be used

as in the control cultures. Toxic substances will induce a decrease of the cell density in comparison to the controls which remain at constant cell numbers.

In comparison to the batch culture method the advantage of continuous cultures lays in the fact that the algae are exposed in permanence to a continuous flow of new medium mixed with waste water. The culturing conditions remain much more constant at non limiting nutrient conditions and this flow through prevents the algae to enter into the stationary phase. For this reason, flow through experiments can last for a much longer time than batch cultures and permit the determination of chronic effects.

Materials and chemicals

In addition to the materials and chemicals listed in Part I, metering pumps for seawater media and the waste waters, and air pumps are needed.

Experimental procedure

(1) The experimental procedure is analogous to that exposed in Part I. Metering pumps have to be installed to achieve a continuous and constant inflow of seawater and seawater-waste water mixtures into the test bottles and a corresponding outflow of same volumes of cultures. To achieve a homogeneous distribution of the algae a slight turbulence of the cultures is realized by a gentle aeration (40 ml air/min.).

(2) In analogy to the batch culture experiments stock cultures are kept in f/2 medium and the cultures are preadapted in N- and P enriched seawater. The tests are run at relatively low cell density which, for example, for dinoflagellates is held at about 1,000 cells ml⁻¹. With diatoms, Chaetoceros socialis is held at 100 cells ml⁻¹ and Coscinodiscus granii at 4 cells ml⁻¹, respectively. Phaeocystis poucheti cultures are held at 2,000 cells ml⁻¹. Flow rates for Scrippsiella faeroense are 530 ml l⁻¹d⁻¹ and 370 ml l⁻¹d⁻¹ for Prorocentrum micans. With the diatoms Coscinodiscus granii and Chaetoceros socialis the flow rate is 180 and 2,300 ml l⁻¹d⁻¹, respectively. The analyses, which are identical to those outlined for the batch culture tests, (see Part I) have to be carried out as long as the control cultures remain in the exponential stage of growth.

Expression of the results

Growth curves and "in vivo" chlorophyll contents are expressed graphically

in comparison to the curves for the controls. This serves as basis for determining the inhibition which can be detected when there is a significant deviation in comparison to the controls. Morphological aberration of the cells can be considered as an additional criterion.

Ludwig Karbe

ANNEX III

Universität Hamburg

Institut für Hydrobiologie u. Fischereiwissenschaft

Zeiseweg 9 D-2000 Hamburg 50

CHRONIC TOXICITY TEST USING CLONAL MARINE HYDROIDS

Test organisms: *Eirene viridula* (PERON & LESEUR 1809)
Strain Hamburg¹

Hydroida, Campanulidae

Campanularia flexuosa (HINKS 1861)

Strain Plymouth¹

Hydroida, Campanulariidae

General

Various species of marine hydroids are capable of being cultured in the laboratory with relative ease over a longer period of time by vegetative reproduction (as a clonal strain). Some of these species exhibit a high degree of sensitivity to toxic influences. The deleterious effects manifest themselves in easily observable morphological alterations on the individual polyp. Stages of increasing redifferentiation are associated with increasing levels of toxicity. An easily quantifiable parameter of sublethal effects is the reduction in colonial growth (Rate of budding new hydranths), (Karbe, 1972; Stebbing, 1976).

Range of application

Estimation of the toxicity of soluble, colloidal soluble, or finely suspended material under standard conditions in sea water at 20°C.

Bioassay of substances released from solids into sea water.

1) In order to guarantee reproducible results, it is requisite the testes be performed only with hydroids derived from these strains of genetically identical material.

Disturbances

Disturbances during the course of experimentation occur particularly with the utilization of unsuitable or improperly stored sea water, with the utilization of culture vessels of unsuitable material, as well as a consequence of an input of trace contaminants from the laboratory. The accidental transfer of an undesirable organism could produce disturbances through excessive growth of filamentous algae and bacteria.

Culture vessels for Eirene viridula

hemispherical glass dishes with flat bottom of approx. 200ml cover discs

Culture vessels for Campanularia flexuosa and Eirene viridula
all-glass aquaria approx. 2 l

glass plates approx. 7 x 9cm

holder, each to stand 6 glass plates per culture vessel

Apparatus

incubator (20°C) or thermostatically regulated waterbath

drying oven

(Autoclave)

transport, and storing containers for sea water of glass or of in sea water aged PE

all-glass filter equipment for membrane filters

membrane filters 0,15 and 0,6 μ m, prefilters

wide mouthed glass flasks for Artemia cultures

full-glass aquarium completely darkened, with the exception of an opening at a lower corner

aeration pump

membrane filter capsule for air filtration (eventually additional filter with activated charcoal)

pipettes for air immission

large pipette with rubber squeeze bulb

hose material, T-piece, dosage valve
sieve covered with 100 m plankton gauze
scissors, forceps, scalpel, razor blades
Nylon line 0,2mm Ø
large petri dish
dissecting microscope

Cleaning culture vessels

Culture vessels and glass plates (with nylon string) are to be cleaned sequentially with hydrochloric acid, acetone (or alcohol) and running water. Any plastic material, which comes into contact with the culture medium, should be leached several weeks in sea water.

Culture medium

Good quality, offshore natural sea water. Transport and storage at best in glass containers. Plastic containers are appropriate, only after having been filled for a longer period of time with sea water, until not releasing any further toxic substances. The water has to be filtered before use through a pressure all-glass filtration apparatus, using pre-filter and membrane filter 0,15 µm.

Feeding

As food 3 days old larvae of *Artemia salina* are used. For breeding the larvae, approx. 3-5g *Artemia* eggs are incubated in 2-2,5 l sterile-filtered sea water at room temperature (better at 23° C) and strong aeration. Before feeding the larvae are separated from undeveloped eggs and egg shells. For this purpose, the larvae and their culture medium are transferred to an all-glass aquarium, which is darkened completely, with the exception of one lower corner being left transparent. The larvae accumulate in the illuminated region of the aquarium, where they are withdrawn by suction. Before feeding, the larvae are placed on a sieve and washed with sea water.

Stock cultures

The preservation of *Eirene viridula* stock cultures takes place in darkened incubators at 20°C in glass dishes. Culturing of free floating colonies is the simplest. They are to be rejuvenated by cutting. Feeding is performed two times weekly with the provision of *Artemia* larvae in surplus. The colonies are to be transferred 1 hour after feeding into fresh sea water for the removal of excretes and surplus *Artemia* larvae.

Culturing of *Campanularia flexuosa* takes place on glass plates, which stand vertically in 2 l all-glass aquaria, aerated at 20° C.

The induction of a new colony is carried out by tying a piece of the old stock colony (1 or 2 small uprights with attached stolon) with Nylon thread in the middle of a glass plate. After a few days the colony will attach itself and the thread can be removed. After having become too extensive, the colonies are reestablished through new daughter colonies. Feeding followed with water change three times weekly.

Testing procedure

The toxicological examination of the substance in question should, if possible, be conducted in two parallel series using both test organisms. *Campanularia flexuosa* has proven somewhat more sensitive (resp. faster) in their reaction to toxic substances, but it is also more susceptible to disorders during experimentation.

The concentrations (or doses) chosen for the determination of dose-effect relationships should be in exponential steps, in a range that sublethal, as well as, lethal reactions are taken into account. The reaction of six colonies in the control, as well as, in all test sets are to be determined.

For this purpose of testing, it is recommended to prepare a larger number of daughter colonies of both species. At the beginning of the tests, the number of individual polyps per colony should be reduced to approx. 10 to 12 through separation of the surplus uprights (scalpel, razor blade).

The plates with the attached hydroids are placed (randomly) in the experimental vessels, 6 per basin. The basins are aerated.

Temperature 20° C. The cultures of *Eirene viridula* are fed each third day (or alternatively two times per week), those of *Campanularia flexuosa* are fed each day during the course of the experiments.

One hour after feeding the plates of hydroids are transferred into fresh sea water with a new application of the substance: to be tested. Duration of experimentation for *Campanularia flexuosa* two, for *Eirene viridula* three weeks.

At the beginning of the experiments and during the experiments at least at the end of each week the colony size is determined by counting the individuals under a stereo microscope with 12x enlargement. Hydranths with fully developed tentacles or conspicuous parts of tentacles are counted, for *Campanularia flexuosa*, hydranths and blastostyles.

In the case of *Eirene viridula* additionally morphological defects observable as states of increasing redifferentiation of the hydranths are to be accounted for.

Evaluation of the results

a) Effects on the budding rate (colony growth)

The results of the counting the hydranths presented as a function of time in the half-logarithmic coordinate system. This results in a straight line relationship for the exponential phase of colony growth, whose slope can be employed as a measure of growth.

Budding coefficients are calculated using the formula

$$k = \frac{\ln n_2 - \ln n_1}{t_2 - t_1}$$

k = budding coefficient

n_2 = number of hydranths (+ blastostyles) at time t_2

n_1 = number of hydranths (+ blastostyles) at time t_1

$t_2 - t_1$ = time difference between beginning and end of the respective period of growth.

Separate coefficients for the individual phases (1 week, 2 week) may be calculated, should fluctuations occur during the course of experiments. The arithmetic mean, standard deviation and the standard error are calculated for each experimental set of 6 values. In order to arrive at comparable results, these values are then recalculated into a % of the mean budding rate of the respective control test. The values obtained

are presented for dose-effect relationships as a function of the concentration or dosis in water. Stimulating effects result in values greater than 100%, inhibiting effect result in values less than 100% and detrimental effects, which lead to a successive degeneration of the individual hydranths and colony in negative values.

An effect is considered significant, if a deviation from the controls is greater than three-times the pooled standard error calculated considering all experimental sets. This calculation assumes the previous proof for homogeneity of the variances. (For further details see STEBBING, 1976).

b) Effects on hydranth's morphology

(Stages of increasing redifferentiation)

In addition to a decrease in budding rates morphologically distinct alterations of the hydranths can be ascertained with an increase in detrimental effects, which lead to a sequential degeneration beginning from the tentacle tip of the individual polyp and ending finally with the full disintegration of the entire colony. These phenomena are visible only on *Eirene viridula* not protected by a theca. Six levels of increasing redifferentiation can be described as stages of increasing detrimental effects:

- I. Polyps are of nearly normal appearance, only slight artefacts of different type (swollen, clefted, coalesced) are visible on the tips. Occasionally stolon ends have grown out twisted.
- II. Tentacles degenerate sequentially, appearing rigid and frequently thickened.
- III. Complete degeneration of tentacles, mostly accompanied with rounding of the polyp heads, on which tentacles are absent.
- IV. Polyp heads drop off or their material is retracted into base of the uprights.
- V. Full degeneration of the polyp colony, with exception of the stolonial parts.
- VI. Destruction of stolon tissue as well.

Level I to V destruction frequently demonstrate restoration after transfer to normal sea water, through budding of new hydranths or through regeneration of only partially affected individual polyps. Stages of increasing destructions are related to increasing toxicity concerning sub-lethal and lethal effects. An effect is considered significant, if more than 20% of the colony is affected.

Specification of the results

Specification of the threshold concentration for significant effects on the budding rate. (EC_3)

Specification of the threshold concentration for significant morphologically defined effects. (EC_{20} I, EC_{20} II, EC_{20} III)

Comments

Under special conditions, it can be necessary to deviate from the standard-test procedure. The nature of the substances to be tested can make it necessary to work with a static system with single dosage of the substance, or in a flow-through system with continuous dosage. In both cases, the hydroids are to be fed externally, whereby, the excretion-time is to be allowed for.

In other cases, it may be desired to perform tests under higher or lower temperatures. The hydroid test can be performed, with *Campanularia flexuosa* in the temperature range of approx. 10-20° C, with *Eirene viridula* 15-30° C (Borchardt, 1979).

References

- Borchardt, Th. (1979): Wachstumsuntersuchungen an marinen Hydroiden. Diplomarbeit Fachbereich Biologie der Universität Hamburg.
- Karbe, L. (1972): Marine Hydroiden als Testorganismen zur Prüfung der Toxizität von Abwasserstoffen. Die Wirkung von Schwermetallen auf Kolonien von *Eirene viridula*. Mar.Biol.12,316-328
- Stebbing, A.R.D. (1976): The effects of low metal levels on a clonal hydroid. J.mar.biol.Ass.U.K.56,977-994

ANNEX V

BIOACCUMULATION TESTING WITH THE COMMON
MUSSEL, MYTILUS EDULIS

W. ERNST
Institut für Meeresforschung
Am Handelshafen 12
2850 Bremerhaven

The scope of bioaccumulation tests is the determination of concentration factors at steady state conditions, if possible. In most studies fish has been used as test organisms, however, in order to attain plateau levels in fish, long experimental periods are required and the determination of test compounds in numerous samples make great demands on the analytical procedures required. From appropriate experiments with the common mussel, *Mytilus edulis*, these animals were found to equilibrate very fast and from the type of experiment the analytical work could be reduced. Mussels are very abundant in coastal areas, easy to collect and are widely used as monitor organism for environmental pollution. Preliminary results with *Mytilus* and a number of different test compounds are presented in this paper.

Test-procedure with mussels

Wild living *Mytilus edulis* from the North Sea (Helgoland) with a shell length between 4 and 5 cm were selected and maintained^{*)} in clean seawater of 33 ‰ salinity, 10° C and aeration with filtered air before they were exposed to the chemical. Five to ten animals each are kept throughout the adaptation - and the exposure period in stainless steel baskets of a size of 14 x 14 x 14 cm. (Fig. 1) Usually, 10 mussels/4 l water or a biomass of about 6 g wet/1 l water are used. For substances with concentration factors higher than 1000 it is advantageous to lower the biomass/water ratio in order to facilitate water analysis (Fig. 8).

10 l-glass aquaria (25 cm x 18 cm x 21 cm; l x d x h) containing 4 l of seawater (33 ‰ salinity, 10° C, 7 - 8 l air/h) are used in the uptake experiments. The aquaria were maintained at a temperature of 10° C by a thermostat (fig. 1). Test compounds, dissolved in ethanol, are injected by means of a microliter syringe into the water (10 - 100 µl) to give the desired concentration. The injected substance is homogeneously distributed in the water by stirring and the actual concentration of the chemical is measured. The basket containing the mussels is now transferred from the adaptation tank to the test aquarium and the concentration of the che-
*) for at least 48 hs.

mical in the water is determined after 1, 2, 4, 7 and 24 hours. The measured concentrations are plotted vs. time of uptake and from the resulting curve it can be decided at which time intervals further water samples have to be drawn for analysis. The water taken from the aquaria for analyses is not supplied but should not exceed a total of 10 % of the initial volume of water. The test is terminated when the substance concentration remains practically constant in the water during a period of 48 hrs ("steady state"). The mussels are removed and worked up piece by piece. Each mussel is rinsed with a few ml of clean seawater of 10° C and 33 ‰ salinity. The shell is opened with a scalpel according to fig. 2, and the enclosed water is allowed to drain for one minute. After this the mantle tissue is carefully lifted and after a further minute of draining the soft body is removed. The wet tissue is weighed on an aluminium foil, using an analytical balance, and the foil has to be pre-washed with acetone. The sample is then wrapped in the foil and deep-frozen at -20° C.

Analytical procedures

The deep-frozen samples can be analyzed individually or after total or partial pooling. The most important steps are quantitative extraction of the compounds from the homogenized material, removing of interfering substances such as lipids, pigments and others, and/or appropriate derivatization.

The analytical procedures to be applied depend largely on the nature of the test compound. Therefore, no methods exist which are applicable for all types of substances. Generally, analyses of test substances in water are less complicated than in animals.

For a number of unpolar and weakly polar substances the following method has been successfully used for animals.

4 g of the frozen sample are ground in an electric driven mortar mill, fitted with an agate mortar and pestle, together with 16 g anhydrous sodium sulphate and 5 g of quartz sand to give a dry tissue powder. The powder is transferred to an extraction column (fig. 4) which had been charged before with a layer of 1 cm quartz wool and 2 cm anhydrous sodium sulphate. 110 ml of a mixture of n-hexane/acetone (2:1 v/v) is poured onto the prepared column and the eluat (extract) is collected over night. The solvent mixture and quantity may vary according to the nature of the test compound.

For removal of fat the extract is concentrated near to dryness redissolved in 5 ml n-hexane and transferred to Al_2O_3 column (fig. 1) with a layer of 1 cm quartz wool on the bottom and 8 g Al_2O_3 neutral (Firma Woelm), heated 3 hours at $850^\circ C$ and deactivated by addition of 5 % water. The vessel containing the extract is washed three times with each 2 ml of n-hexane and the washings are transferred to the column. Each washing should be allowed to drain into the Al_2O_3 before the next washing is added. After this 40 ml of the n-hexane are added. The lipid free eluat (capacity of the column 250 mg fat) can be used after concentration directly for analysis or may be further fractionated on florisil.

It should be noted that, although the extraction recovery may be satisfactory, the clean-up on aluminium oxide and/or florisil may result in severe losses of the compounds used. Therefore, these procedures have carefully to be checked before for every new compound in question.

Evaluation:

The concentration factor at steady state is

$$CF = \frac{C_{M_{St}}}{C_{W_{St}}}$$

$C_{M_{St}}$: concentration of the compound in mussels in ng/g wet weight

$C_{W_{St}}$: concentration of the compound in the water in ng/g

Results

More than 300 individuals of *Mytilus edulis* including 10 different test compounds have been tested with the system described (table 1). The results were correlated with the water solubility of the substances and were found to be comparable with those reported in the literature with other species of shellfish. (fig. 5) The test substances incorporated in this study cover a CF - range from 100 - 10 000. Generally, the period to attain steady state was about 200 hrs or 8 days. Because fish require, as a rule, a considerable longer time for equilibration it was interesting to compare our data with those obtained with fish. No marked differences were found with γ -HCH and pentachlorophenol; for substances with concentration factors (CF) higher than 1000 a regression equation, utilizing CF and solubility data or partition coefficients obtained from rainbow trout, were used for the calculation of CF's. (table 1) It can be shown that up from a concentration factor of 3000 experimental values with mussels agree well with those calculated for the fish. This supports the assumption that mussels may be well comparable with muscle tissue of fish and that equilibration can be achieved faster in mussels than in fish.

Temperature differences between 5 and 15° C are not very likely to influence the CF in mussels but the lipid content of the mussels of roughly 1 - 2 % can be correlated with the concentration factor as could be shown with γ -HCH. An example of the scatter of values when analyzing individuals is given in fig. 6. Results from an average of 5 - 10 animals are well comparable but individual values may differ considerably (\pm 30 %). Substantial metabolic activity of mussels has only been observed with phenols so far. Phenolic compounds as e.g. PCP will be conjugated as sulphates. This process can be followed easily (fig. 7) and has obviously no remarkable influence on the concentration factor.

Extended interpretation of the mussel test:

The test as described so far comprises the determination of the steady state by analysis of the water during the equilibration period and the analysis of animals after the test is terminated.

In order to obtain a fast general view of the approximate concentration factors of a large number of chemicals the test may also be used in a simplified form by analyzing the water alone. Provided that the decrease in the compound concentration in water is exclusively due to uptake of the substance by the mussels, the correlation between the CF and the actual concentration in the water is described in fig. 8. From this a rough estimation of the concentration factor can be achieved solely from the concentration of the compound in the water. There may be, of course, factors which are not considered in this rather simple balance, such as adsorption of the substance to walls of the aquarium, volatilization, formation of not detectable metabolites etc. However, all these processes tend to a reduction of the concentration factor as derived from the rough estimate procedure. As a result, these estimates represent the maximum concentration factors assuming ideal conditions. In fact the real concentration factors are lower according to the above mentioned process. A blank aquarium can be used additionally, in order to compensate physical factors; thus giving an improved rough estimate.

From the results obtained a number of advantages are apparent when using mussels as test organisms:

Advantages of the common mussels as test organisms in a bioaccumulation test with organic chemicals.

- Mussels exhibit a high ventilation rate of more than $2 \text{ l x h}^{-1} \text{ x g dry weight}^{-1}$. This provides a rapid distribution of the chemical among the tissues and a fast approach to the steady state.
- "Steady state" conditions can easily be determined from water analysis alone.
- The high ventilation rate of *Mytilus* is attained at low temperatures of 5 to 10° C. Loss rates of volatile test substances are comparatively low at these temperatures; this favours static experiments.
- The test animals have not to be fed throughout the test.
- The equipment for conducting the test is inexpensive and easy to maintain.
- The size of mussels (2 - 3 g wet weight) make possible to analyse individual samples as well as pooled samples.
- The total amount of test compounds required in the test is relatively small. This is important from the standpoint of laboratory contamination and of costs if labeled compounds should be used.

- Absorption of test compounds to the walls of aquaria have been found negligible with the components tested so far (less volatile substances).
- Contrary to testing of bioaccumulation in a constant flow system all animals in the test aquarium contribute to an average uptake curve, instead of only few samples which may behave different because of different physiological parameters.

- Metabolic processes (e.g. conjugation of phenols) can easily be detected in the water, and their effect can be estimated.
- The use of solubilizers is dispensable.
- The water in static experiments with mussels remains clear throughout the test period. This is not the case in static experiments with fish, where the water becomes turbid and contaminated with bacteria.
- Mussels are recommended world-wide as monitor organisms. This offers the opportunity to compare the test results with data reported in the literature.

Conclusion

From the test results obtained with the common mussel, *Mytilus edulis*, the following conclusion can be drawn: *Mytilus* appears to be a suitable test organism for a rapid screening of organic chemicals with respect to their bioaccumulation in aquatic biota. It is an important prerequisite that the test compounds are not volatile; not more than 10 % per 24 h should evaporate. The tests can be operated stepwise according to the precision required, as follows:

type of test	analytical requirements	result
rough estimate test	analysis of water at different times: blank aquarium is recommended	maximum ideal bioconcentration factor at steady state; sufficient for CF <100
full test	analysis of water at different times; analysis of animals at the end of the test (single or pooled)	real concentration factors at steady state

Figure 1: Test aquarium. A: side view, B: ground plan. 1: thermostat, 2: water, 3: outer tank with water of constant temperature, 4: glass tank with seawater, 5: stainless steel baskets with test animals, 6: air inlet, 7: activated charcoal filter, 8: flow meter.

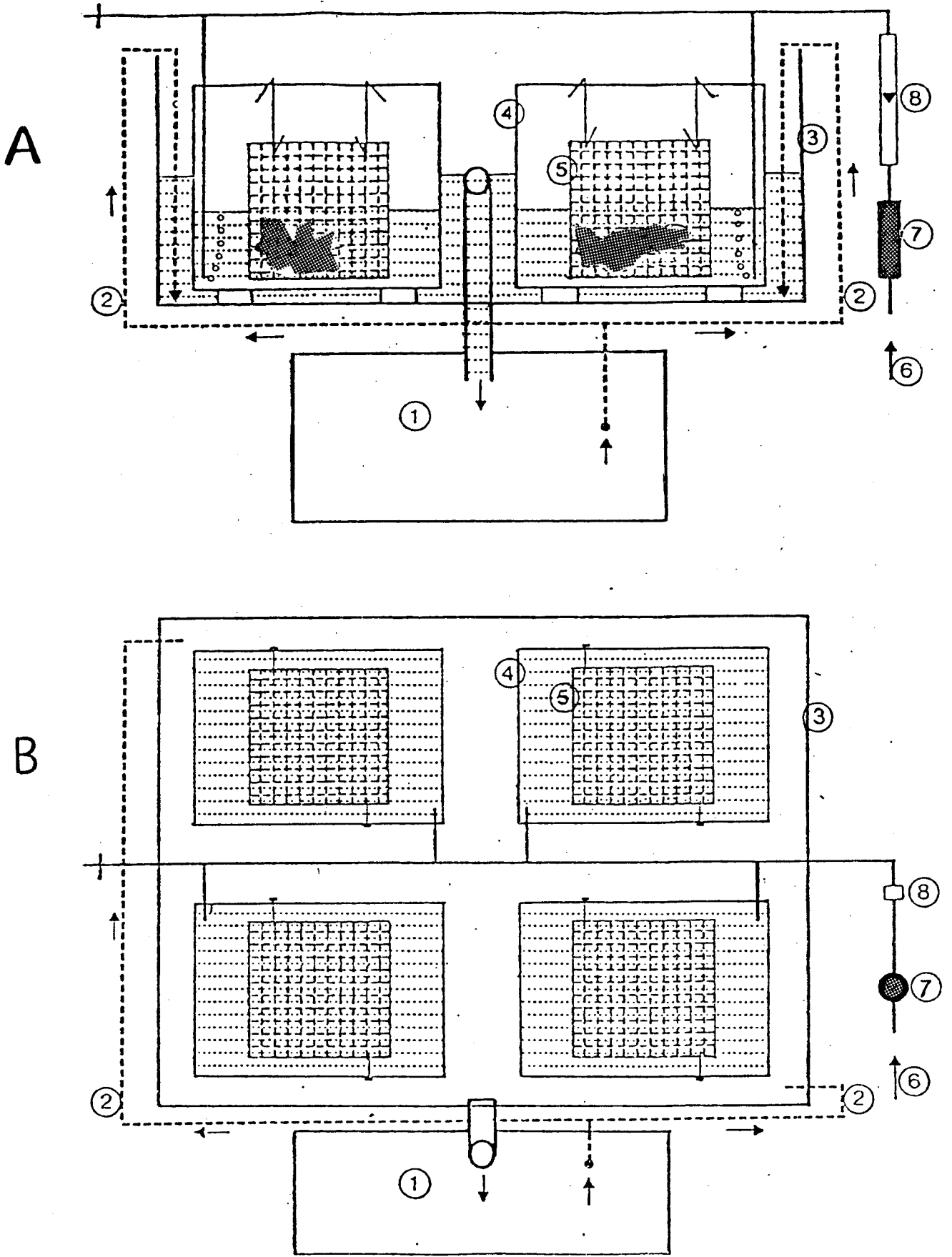

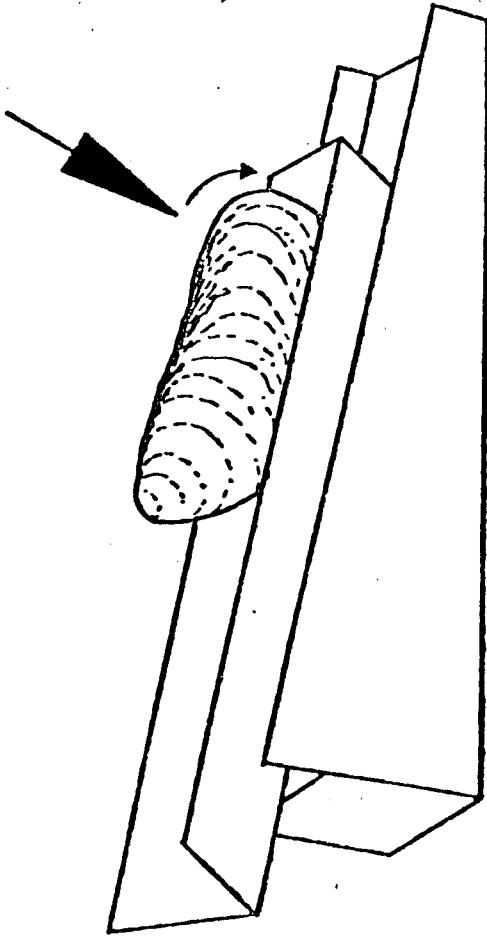

Figure 2: Device for preparation of mussels.
Cutting of the adductor muscle

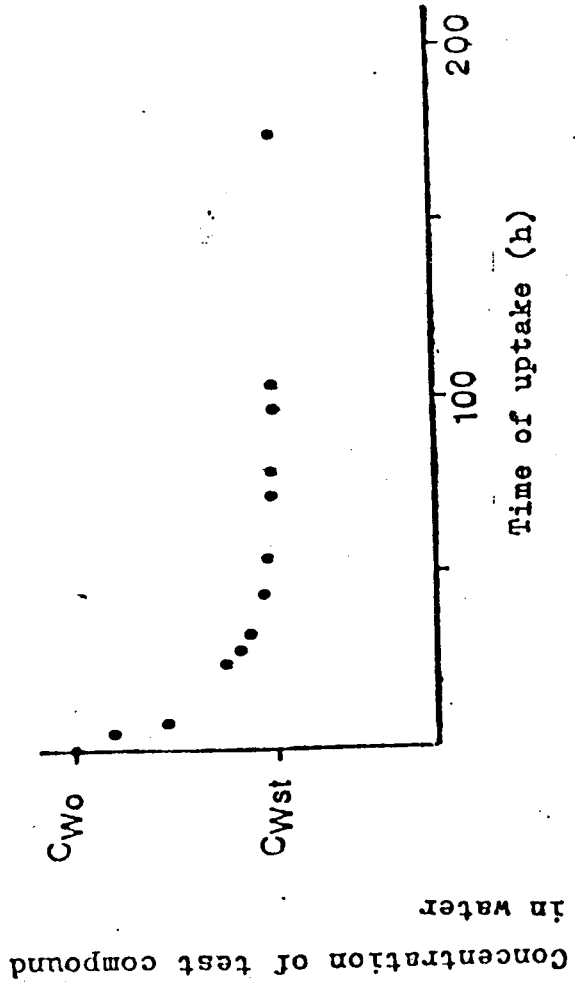

Figure 3: Typical curve of equilibration with the common mussel.

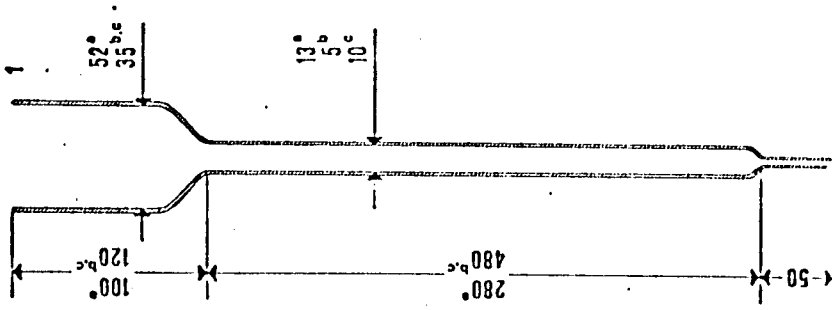

Figure 4: Measures for glass columns(mm):
a) extraction column
b) Al_2O_3 -column
c) Florisil column

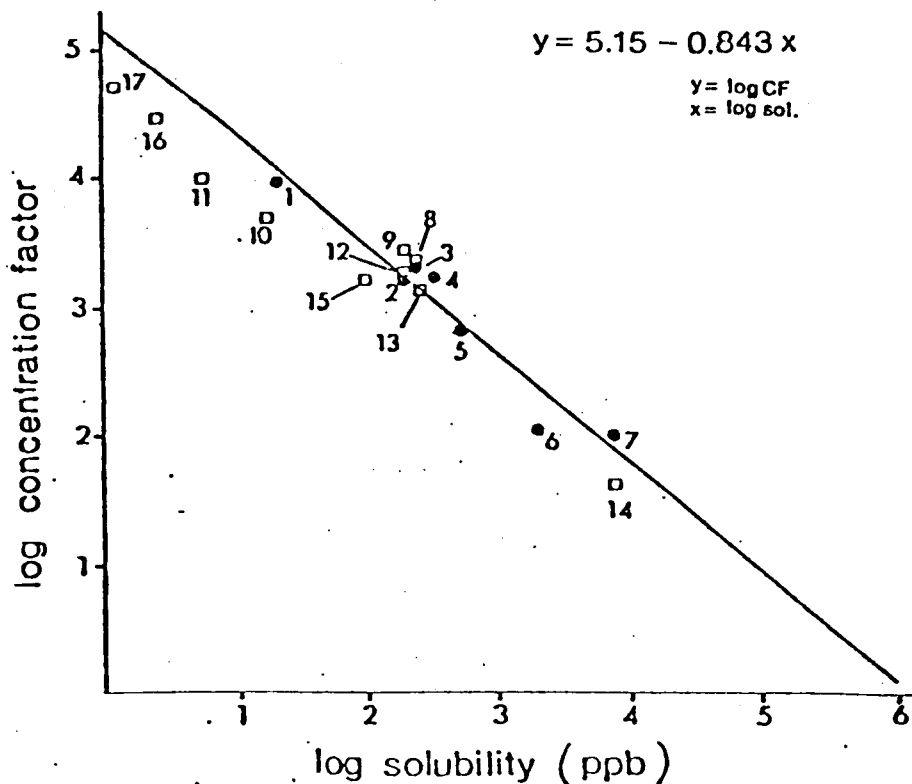

Figure 5: Correlation between bioconcentration factors of different organohalogen compounds and water solubility in shell fish.

Nos. 1 - 7: Values obtained in the proposed test procedure with *Mytilus edulis* ("steady state approach")

Nos. 8 -17: Values reported in the literature for oysters and clams.

- | | |
|-------------------------|---------------------------------------|
| 1. DDD | 10. aldrin |
| 2. dieldrin | 11. DDT |
| 3. endrin | 12. dieldrin |
| 4. heptachlorepoide | 13. endrin |
| 5. α -endosulfan | 14. γ -HCH |
| 6. α -HCH | 15. methoxychlor |
| 7. γ -HCH | 16. 2,3,4,2',5'-pentachlorobiphenyl |
| 8. endrin | 17. 2,4,5,2',4',5'-hexachlorobiphenyl |
| 9. dieldrin | |

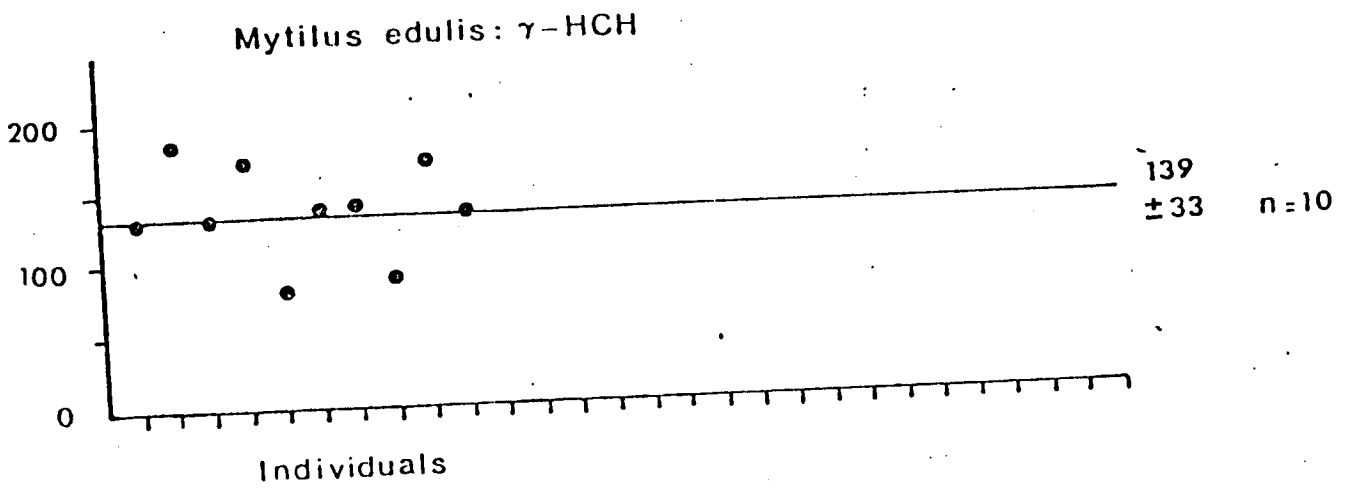
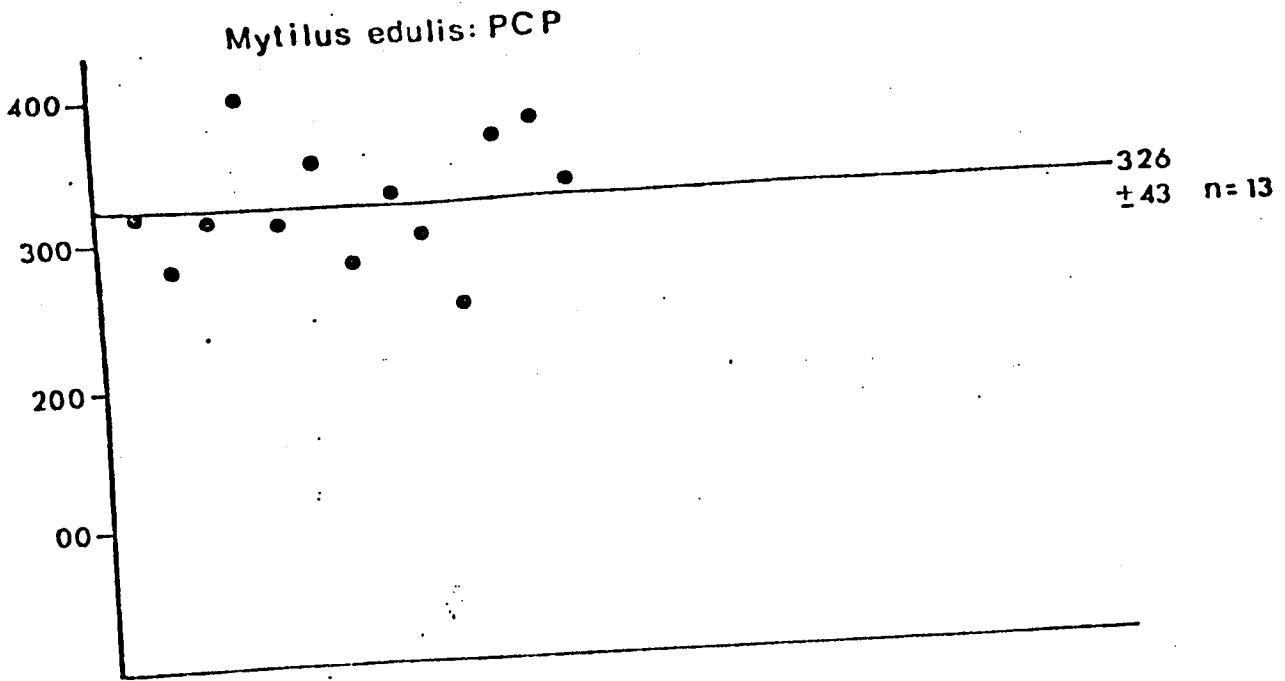

Figure 6: Scatter of concentration factors for γ -HCH and pentachlorophenol from analysis of individuals.

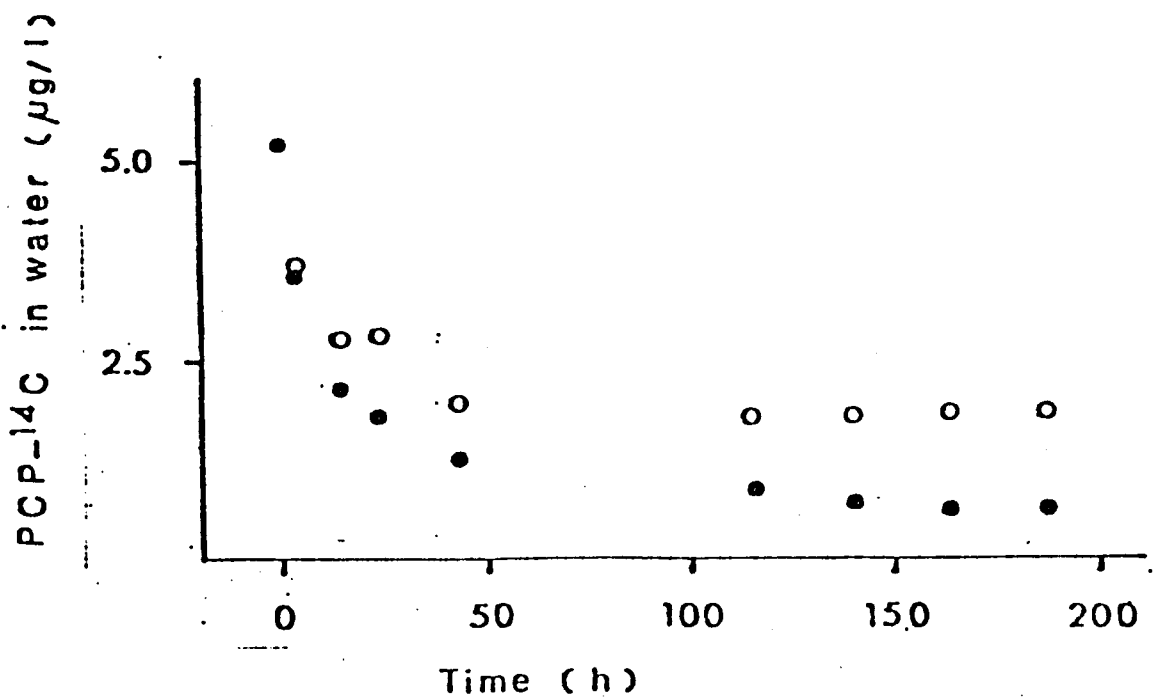

Figure 7: Uptake of ¹⁴C -PCP from water and formation of conjugated PCP in Mytilus

- : Free ¹⁴C- PCP
- : Total ¹⁴C -PCP (free + conjugated)

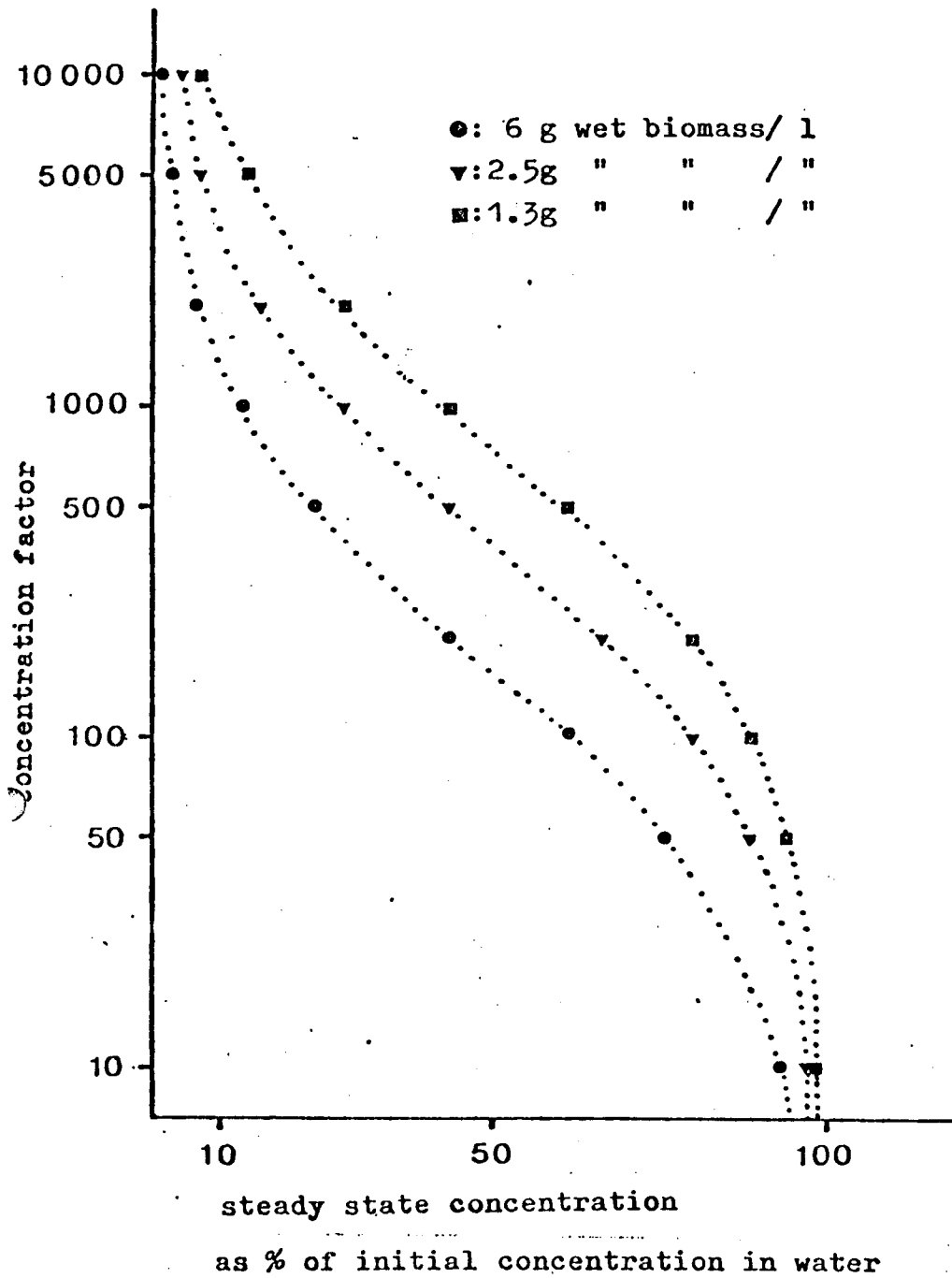

Figure 8: Relationship between concentration factor and steady state concentration in water at different ratios of biomass / L water.

References:

- BEDFORD, J.W. and M.J. ZABIK
Bioactive compounds in the aquatic environment.
Uptake and loss of DDT and dieldrin by fresh water
mussels. Arch. Environ. Contam. Toxicol. 1, 97-111
(1973)
- BUTLER, P.A. Influence of pesticides on marine ecosystems.
Proc. Royal Soc., Ser. B, 177, 321-329 (1971)
- ERNST, W. Determination of the bioconcentration potential of
marine organisms. - A steady state approach. 1. Bio-
concentration data for seven chlorinated pesticides
in mussels (*Mytilus edulis*) and their relation to
solubility data. Chemosphere 6, 731-740 (1977)
- GUNTHER, F.A., W.E. WESTLAKE and P.S. JAGLAN
Reported solubilities of 738 pesticide chemicals in
water. Res. Rev. 20, 1-148 (1968)
- MASON, J.W. and D.R. ROWE
The accumulation and loss of dieldrin and endrin
in the eastern oyster. Arch. Environ. Contam. Toxi-
col. 4, 349-360 (1976)
- VREELAND, V. Uptake of chlorobiphenyls by oysters.
Environ. Pollut. 6, 135-140 (1974)
- WEIL, L., G. DURÉ and K.-E. QUENTIN
Wasserlöslichkeit von insektiziden chlorierten
Kohlenwasserstoffen und polychlorierten Biphenylen
im Hinblick auf eine Gewässerbelastung mit diesen
Stoffen. Wass. Abwass. Forsch. 2, 169-175 (1974)